



FCC TEST REPORT
FCC ID: 2AP2N-MAGQOO

On Behalf of

Shenzhen Esorun Technology Co., LTD

Magnetic Wireless Charger

Model No.: MagQoo

Prepared for : Shenzhen Esorun Technology Co., LTD
Address : 101, Dormitory Building, No. 1215, Guihua Community Guanguang Road, Guanlan Street, Longhua District, Shenzhen, China

Prepared By : Shenzhen Alpha Product Testing Co., Ltd.
Address : Building i, No.2, Lixin Road, Fuyong Street, Bao'an District, 518103, Shenzhen, Guangdong, China

Report Number : A2012157-C01-R03
Date of Receipt : December 22, 2020
Date of Test : December 22, 2020–January 20, 2021
Date of Report : January 20, 2021
Version Number : V0

TABLE OF CONTENTS

1. Test Result Summary	5
2. General Information.....	6
2.1. Description of Device (EUT).....	6
2.2. Accessories of Device (EUT)	7
2.3. Tested Supporting System Details	7
2.4. Block Diagram of Connection between EUT and Simulators	7
2.5. Description of Test Modes	7
2.6. Test Conditions	7
2.7. Test Facility.....	8
2.8. Measurement Uncertainty	8
2.9. Test Equipment List	9
3. Test Results and Measurement Data	10
3.1. Conducted Emission.....	10
3.2. Radiated Spurious Emission Measurement	13
3.3. Test Specification.....	21
4. Photos of Test Setup.....	23
5. Photographs of EUT	25

TEST REPORT DECLARATION

Applicant : Shenzhen Esorun Technology Co., LTD
 Address : 101, Dormitory Building, No. 1215, Guihua Community Guanguang Road,
 Guanlan Street, Longhua District, Shenzhen, China
 Manufacturer : Shenzhen Esorun Technology Co., LTD
 Address : 101, Dormitory Building, No. 1215, Guihua Community Guanguang Road,
 Guanlan Street, Longhua District, Shenzhen, China
 EUT Description : Magnetic Wireless Charger
 (A) Model No. : MagQoo
 (B) Trademark : **ESORUN**

Measurement Standard Used:

FCC CFR Title 47 Part 15 Subpart C Section 15.209

The device described above is tested by Shenzhen Alpha Product Testing Co., Ltd. to determine the maximum emission levels emanating from the device and the severe levels of the device can endure and its performance criterion. The test results are contained in this test report and Shenzhen Alpha Product Testing Co., Ltd. is assumed full responsibility for the accuracy and completeness of test. Also, this report shows that the EUT is technically compliant with the FCC CFR Title 47 Part 15 Subpart C Section 15.209 requirements.

This report applies to above tested sample only. This report shall not be reproduced in parts without written approval of Shenzhen Alpha Product Testing Co., Ltd.

Tested by (name + signature).....: Lucas Pang
 Project Engineer 

Approved by (name + signature).....: Simple Guan
 Project Manager 

Date of issue..... : January 20, 2021

Revision History

Revision	Issue Date	Revisions	Revised By
V0	January 20, 2021	Initial released Issue	Lucas Pang

1. Test Result Summary

Requirement	CFR 47 Section	Result
Antenna requirement	§15.203	PASS
AC Power Line Conducted Emission	§15.207	PASS
Spurious Emission	§15.209(a)(f)	PASS
Occupied Bandwidth	§15.215 (c)	PASS

Note:

1. *PASS: Test item meets the requirement.*
2. *Fail: Test item does not meet the requirement.*
3. *N/A: Test case does not apply to the test object.*
4. *The test result judgment is decided by the limit of test standard.*

2. General Information

2.1. Description of Device (EUT)

EUT Name	:	Magnetic Wireless Charger
Model No.	:	MagQoo
DIFF.	:	N/A
Trademark	:	ESORUN
Power supply	:	Input : 5V =2A, 9V =2A, 12V =2A Wireless Output : 5V =1A(5W), 9V =0.83A(7.5W), 9V =1.12A(10W), 9V =1.67A(15W)
Operation frequency	:	112~205KHz
Modulation	:	MSK
Antenna Type	:	Coil Antenna, Maximum Gain is 0dBi (This value is supplied by applicant).
Software version	:	V3.0
Hardware version	:	V1.0
Connector cable loss	:	0.5dB (This value is supplied by applicant).
Intend use environment	:	Residential, commercial and light industrial environment

2.2. Accessories of Device (EUT)

Accessories1 : /
 Manufacturer : /
 Model : /
 Ratings : /

2.3. Tested Supporting System Details

No.	Description	Manufacturer	Model	Serial Number	Certification
1	Wireless load	--	--	--	--
2	Adapter	--	HNFCQ3024UU	--	--

2.4. Block Diagram of Connection between EUT and Simulators

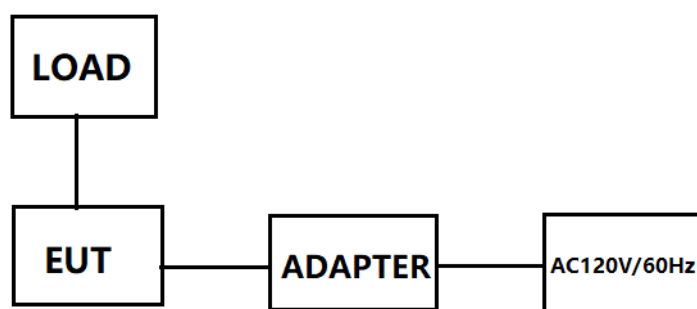

2.5. Description of Test Modes

Channel	Frequency (KHz)
1	145

2.6. Test Conditions

Items	Required	Actual
Temperature range:	15-35°C	24°C
Humidity range:	25-75%	56%
Pressure range:	86-106kPa	98kPa

2.7. Test Facility

Shenzhen Alpha Product Testing Co., Ltd

Building i, No.2, Lixin Road, Fuyong Street, Bao'an District, 518103, Shenzhen, Guangdong, China

June 21, 2018 File on Federal Communication Commission

Registration Number: 293961

July 15, 2019 Certificated by IC

Registration Number: CN0085

2.8. Measurement Uncertainty

(95% confidence levels, k=2)

Item	MU	Remark
Uncertainty for Conducted Emission Test	2.74dB	
Uncertainty for Radiation Emission test in 3m chamber (below 30MHz)	2.13 dB	Polarize: V
	2.57dB	Polarize: H
Uncertainty for Radiation Emission test in 3m chamber (30MHz to 1GHz)	3.77dB	Polarize: V
	3.80dB	Polarize: H
Uncertainty for Radiation Emission test in 3m chamber (1GHz to 25GHz)	4.13dB	Polarize: H
	4.16dB	Polarize: V
Uncertainty for radio frequency	5.4×10^{-8}	
Uncertainty for conducted RF Power	0.37dB	

2.9. Test Equipment List

Equipment	Manufacture	Model No.	Serial No.	Last cal.	Cal Interval
9*6*6 anechoic chamber	CHENYU	9*6*6	N/A	2020.09.02	1Year
Spectrum analyzer	R&S	FSU	1166.1660.26	2020.09.02	1Year
Spectrum analyzer	Agilent	N9020A	MY499100060	2020.09.02	1Year
Receiver	R&S	ESR	1316.3003K03-10208 2-Wa	2020.09.02	1Year
Receiver	R&S	ESCI	101165	2020.09.02	1Year
Bilog Antenna	Schwarzbeck	VULB 9168	VULB9168-438	2019.09.07	2Year
Horn Antenna	SCHWARZBEC K	BBHA 9120 D	BBHA 9120 D(1201)	2020.04.12	2Year
Active Loop Antenna	SCHWARZBEC K	FMZB 1519B	00059	2019.09.07	2Year
Cable	Resenberger	N/A	No.1	2020.09.02	1Year
Cable	Resenberger	N/A	No.2	2020.09.02	1Year
Cable	Resenberger	N/A	No.3	2020.09.02	1Year
Pre-amplifier	HP	HP8347A	2834A00455	2020.09.02	1Year
Pre-amplifier	Agilent	8449B	3008A02664	2020.09.02	1Year
L.I.S.N.#1	Schwarzbeck	NSLK8126	8126-466	2020.09.02	1Year
L.I.S.N.#2	R&S	ENV216	101043	2020.09.02	1 Year
20db Attenuator	ICPROBING	IATS1	82347	2020.09.02	1 Year

Software Information			
Test Item	Software Name	Manufacturer	Version
RE	EZ-EMC	EZ	Alpha-3A1
CE	EZ-EMC	EZ	Alpha-3A1
RF-CE	MTS 8310	MW	V2.0.0.0

3. Test Results and Measurement Data

3.1. Conducted Emission

3.1.1. Test Specification

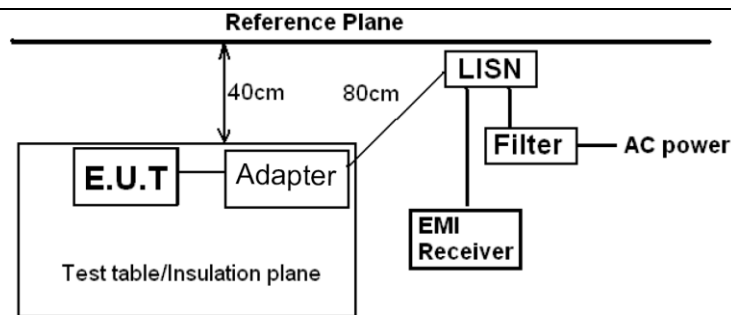
Test Requirement:	FCC Part15 C Section 15.207														
Test Method:	ANSI C63.10:2013														
Frequency Range:	150 kHz to 30 MHz														
Receiver setup:	RBW=9 kHz, VBW=30 kHz, Sweep time=auto														
Limits:	<table border="1"> <thead> <tr> <th rowspan="2">Frequency range (MHz)</th> <th colspan="2">Limit (dBuV)</th> </tr> <tr> <th>Quasi-peak</th> <th>Average</th> </tr> </thead> <tbody> <tr> <td>0.15-0.5</td> <td>66 to 56*</td> <td>56 to 46*</td> </tr> <tr> <td>0.5-5</td> <td>56</td> <td>46</td> </tr> <tr> <td>5-30</td> <td>60</td> <td>50</td> </tr> </tbody> </table>	Frequency range (MHz)	Limit (dBuV)		Quasi-peak	Average	0.15-0.5	66 to 56*	56 to 46*	0.5-5	56	46	5-30	60	50
Frequency range (MHz)	Limit (dBuV)														
	Quasi-peak	Average													
0.15-0.5	66 to 56*	56 to 46*													
0.5-5	56	46													
5-30	60	50													
Test Setup:	 <p><i>Remark</i> E.U.T: Equipment Under Test LISN: Line Impedance Stabilization Network Test table height=0.8m</p>														
Test Mode:	Charging + Transmitting Mode														
Test Procedure:	<ol style="list-style-type: none"> 1. The E.U.T is connected to an adapter through a line impedance stabilization network (L.I.S.N.). This provides a 50ohm/50uH coupling impedance for the measuring equipment. 2. The peripheral devices are also connected to the main power through a LISN that provides a 50ohm/50uH coupling impedance with 50ohm termination. (Please refer to the block diagram of the test setup and photographs). 3. Both sides of A.C. line are checked for maximum conducted interference. In order to find the maximum emission, the relative positions of equipment and all of the interface cables must be changed according to ANSI C63.10: 2013 on conducted measurement. 														
Test Result:	PASS														

3.1.2. Test Data

Please refer to following diagram for individual

Test Mode	: Full Load, Empty Load
Test Result	: PASS
Note:	<p>The test results are listed in next pages.</p> <p>All test modes has been tested, this report only reflected the worst mode. (Full Load)</p> <p>If the limits for the measurement with the average detector are met when using a receiver with a peak detector, the test unit shall be deemed to meet both limits and the measurement with the average detector and quasi-peak detector need not be carried out.</p> <p>If the limits for the measurement with the average detector are met when using a receiver with a quasi-peak detector, the test unit shall be deemed to meet both limits and the measurement with the average detector need not be carried out.</p>

Pol | **Line**

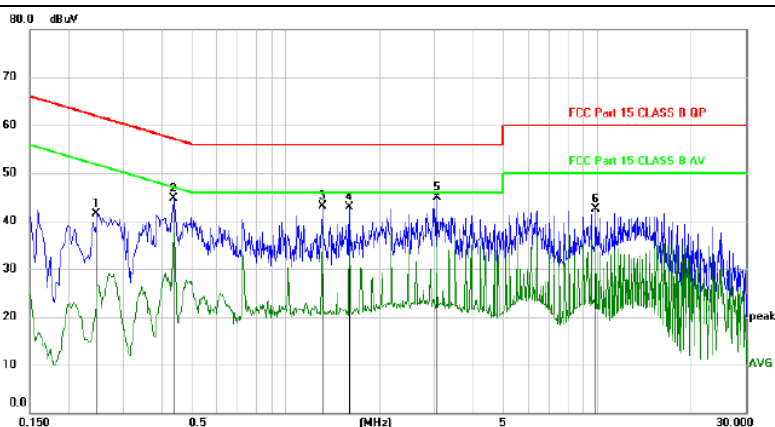

No.	Mk.	Freq.	Reading Level	Correct Factor	Measurement	Limit	Margin		
		MHz	dBuV	dB	dBuV	dBuV	dB	Detector	Comment
1		0.2460	31.58	9.97	41.55	61.89	-20.34	peak	
2		0.4350	34.83	9.95	44.78	57.16	-12.38	peak	
3		1.3080	33.27	9.89	43.16	56.00	-12.84	peak	
4		1.5990	33.09	9.90	42.99	56.00	-13.01	peak	
5	*	3.0540	34.87	9.96	44.83	56.00	-11.17	peak	
6		9.8850	32.38	10.21	42.59	60.00	-17.41	peak	

Pol | **Neutral**

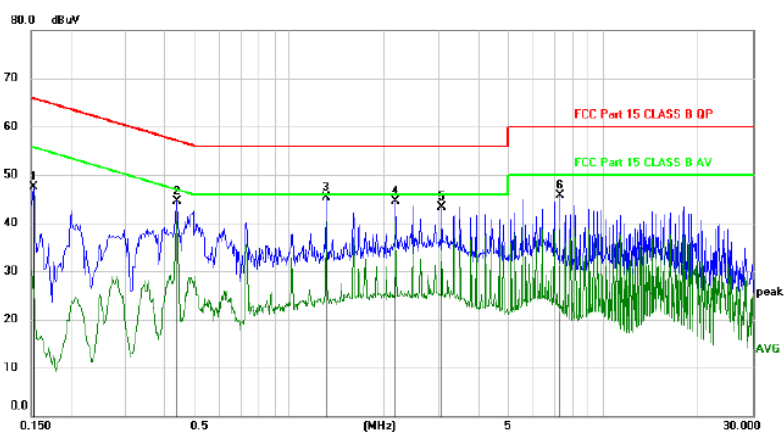

No.	Mk.	Freq.	Reading Level	Correct Factor	Measurement	Limit	Margin		
		MHz	dBuV	dB	dBuV	dBuV	dB	Detector	Comment
1		0.1530	37.56	9.94	47.50	65.84	-18.34	peak	
2		0.4380	34.53	9.95	44.48	57.10	-12.62	peak	
3	*	1.3110	35.32	9.89	45.21	56.00	-10.79	peak	
4		2.1840	34.59	9.89	44.48	56.00	-11.52	peak	
5		3.0570	33.33	9.96	43.29	56.00	-12.71	peak	
6		7.2750	35.53	10.13	45.66	60.00	-14.34	peak	

*:Maximum data x:Over limit !:over margin

Note: Measurement=Reading Level+Correc Factor. Factor=(LISN or ISN or PLC or Current Probe)Factor+Cable

3.2. Radiated Spurious Emission Measurement

3.2.1. Test Specification

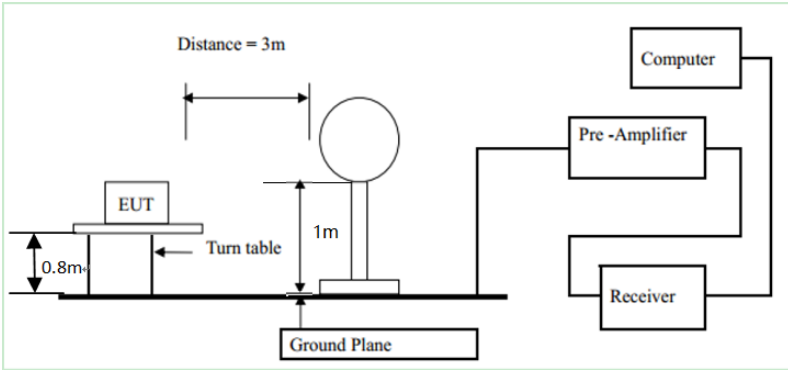
Test Requirement:	FCC Part15 C Section 15.209					
Test Method:	ANSI C63.10: 2013					
Frequency Range:	9 kHz to 25 GHz					
Measurement Distance:	3 m					
Antenna Polarization:	Horizontal & Vertical					
Operation mode:	Refer to item 4.1					
Receiver Setup:	Frequency	Detector	RBW	VBW	Remark	
	9kHz- 150kHz	Quasi-peak	200Hz	1kHz	Quasi-peak Value	
	150kHz- 30MHz	Quasi-peak	9kHz	30kHz	Quasi-peak Value	
	30MHz-1GHz	Quasi-peak	100KHz	300KHz	Quasi-peak Value	
	Above 1GHz	Peak	1MHz	3MHz	Peak Value	
		Peak	1MHz	10Hz	Average Value	
Limit:	Frequency	Field Strength (microvolts/meter)	Measurement Distance (meters)			
	0.009-0.490	2400/F(KHz)	300			
	0.490-1.705	24000/F(KHz)	30			
	1.705-30	30	30			
	30-88	100	3			
	88-216	150	3			
	216-960	200	3			
	Above 960	500	3			
	Frequency	Field Strength (microvolts/meter)	Measurement Distance (meters)	Detector		
	Above 1GHz	500	3	Average		
	5000	3	Peak			
Test setup:	For radiated emissions below 30MHz					
	 <p>The diagram illustrates the test setup for radiated emissions below 30MHz. It shows an Equipment Under Test (EUT) on a turn table at a height of 0.8m. The turn table is on a ground plane. An antenna is positioned 1m above the ground plane and 3m away from the EUT. The antenna is connected to a receiver system consisting of a Pre-Amplifier, a Receiver, and a Computer.</p>					
	30MHz to 1GHz					

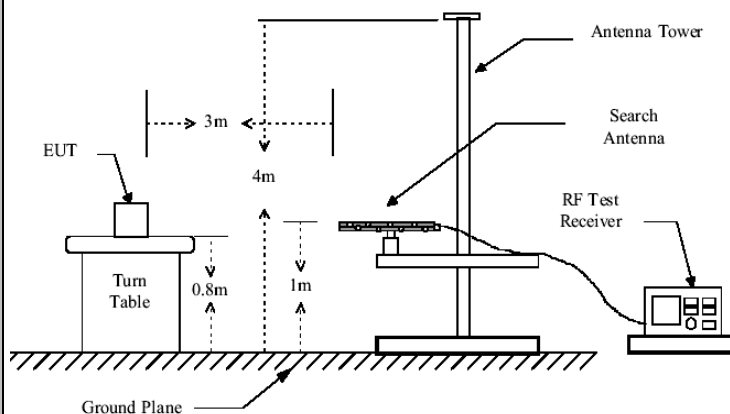

Above 1GHz

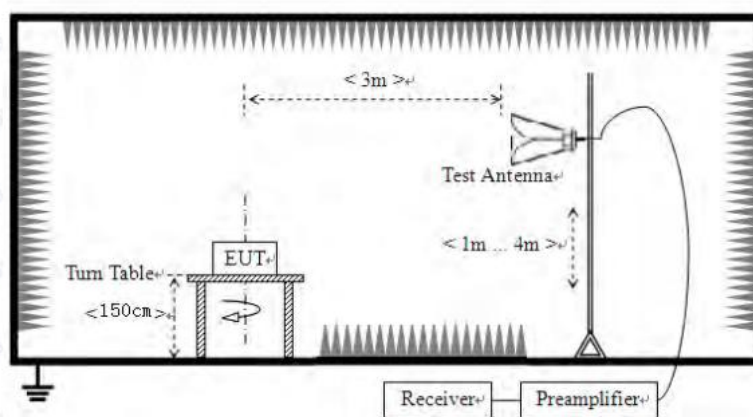

Test Procedure:

1. For the radiated emission test below 1GHz:
The EUT was placed on a turntable with 0.8 meter above ground. The EUT was set 3 meters from the interference receiving antenna, which was mounted on the top of a variable height antenna tower. The EUT was arranged to its worst case and then tune the antenna tower (from 1 m to 4 m) and turntable (from 0 degree to 360 degrees) to find the maximum reading. A pre-amp and a high PASS filter are used for the test in order to get better signal level.
For the radiated emission test above 1GHz:
Place the measurement antenna on a turntable with 1.5 meter above ground, which is away from each area of the EUT determined to be a source of emissions at the specified measurement distance, while keeping the measurement antenna aimed at the source of emissions at each frequency of significant emissions, with polarization oriented for maximum response. The measurement antenna may have to be higher or lower than the EUT, depending on the radiation pattern of the emission and staying aimed at the emission source for receiving the maximum signal. The final measurement antenna elevation shall be that which maximizes the emissions. The measurement

	<p>antenna elevation for maximum emissions shall be restricted to a range of heights of from 1 m to 4 m above the ground or reference ground plane.</p> <ol style="list-style-type: none"> 2. Corrected Reading: Antenna Factor + Cable Loss + Read Level - Preamp Factor = Level 3. For measurement below 1GHz, If the emission level of the EUT measured by the peak detector is 3 dB lower than the applicable limit, the peak emission level will be reported. Otherwise, the emission measurement will be repeated using the quasi-peak detector and reported. 4. Use the following spectrum analyzer settings: <ol style="list-style-type: none"> (1) Span shall wide enough to fully capture the emission being measured; (2) Set RBW=100 kHz for $f < 1$ GHz; $VBW \geq RBW$; Sweep = auto; Detector function = peak; Trace = max hold; (3) Set RBW = 1 MHz, $VBW = 3$ MHz for $f \geq 1$ GHz for peak measurement. <p>For average measurement: $VBW = 10$ Hz, when duty cycle is no less than 98 percent. $VBW \geq 1/T$, when duty cycle is less than 98 percent where T is the minimum transmission duration over which the transmitter is on and is transmitting at its maximum power control level for the tested mode of operation.</p>
Test mode:	Refer to section 4.1 for details
Test results:	PASS

3.2.2. Test Data

Please refer to following diagram for individual

Frequency Range	: 9KHz~30MHz
Test Mode	: TX: 145KHz
Test Results	: PASS
Note:	<ol style="list-style-type: none">1. The test results are listed in next pages.2. This mode is worst case mode, so this report only reflected the worst mode. (Full Load)3. If the limits for the measurement with the average detector are met when using a receiver with a peak detector, the test unit shall be deemed to meet both limits and the measurement with the quasi-peak detector need not be carried out.

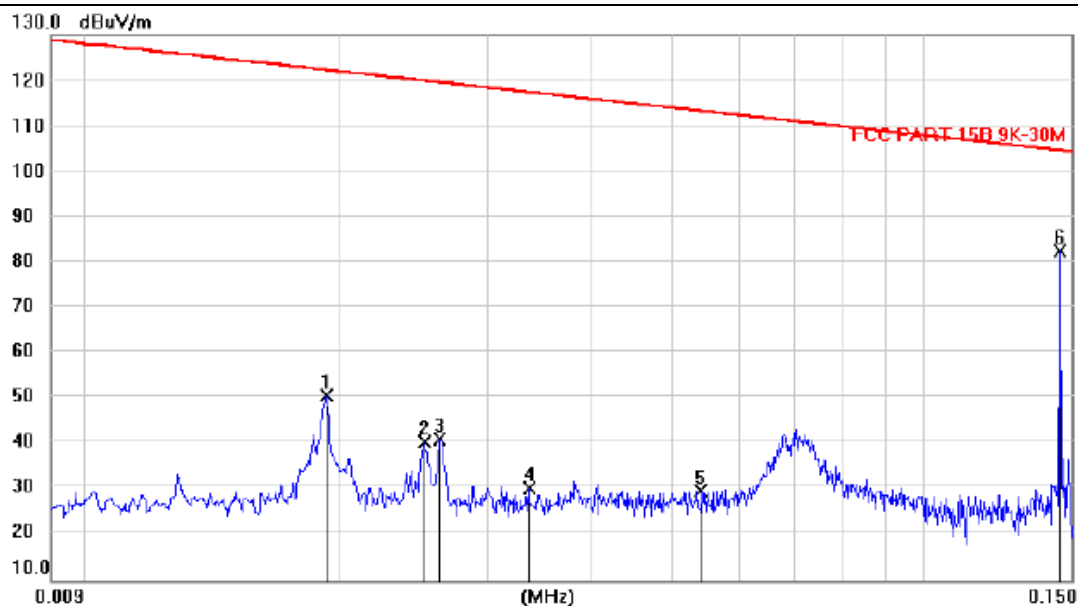

No.	Mk.	Freq. MHz	Reading Level dBuV	Correct Factor dB	Measure- ment dBuV/m	Limit dBuV/m	Margin dB	Detector	Antenna Height cm	Table Degree degree	Comment
1		0.0192	29.26	21.27	50.53	122.2	-71.68	peak			
2		0.0252	19.39	21.12	40.51	119.8	-79.33	peak			
3		0.0263	20.04	21.09	41.13	119.4	-78.34	peak			
4		0.0336	9.51	20.79	30.30	117.3	-87.03	peak			
5		0.0541	9.66	19.96	29.62	113.1	-83.57	peak			
6	*	0.1454	62.34	20.13	82.47	104.5	-22.11	peak			

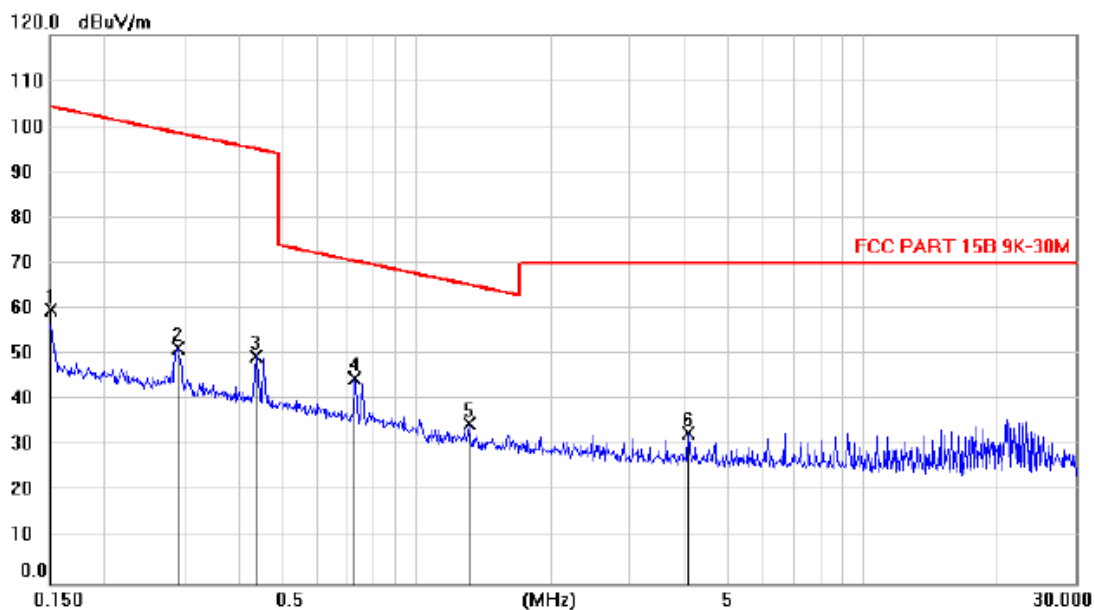

No.	Mk.	Freq. MHz	Reading Level dBuV	Correct Factor dB	Measure- ment dBuV/m	Limit dBuV/m	Margin dB	Antenna Height cm	Table Degree degree	Comment
1		0.1501	39.52	20.20	59.72	104.3	-44.58			peak
2		0.2896	31.60	20.00	51.60	98.58	-46.98			peak
3		0.4364	30.01	19.79	49.80	95.01	-45.21			peak
4	*	0.7265	25.03	19.84	44.87	70.53	-25.66			peak
5		1.3045	15.01	20.08	35.09	65.36	-30.27			peak
6		4.0689	11.83	21.09	32.92	70.00	-37.08			peak

*:Maximum data x:Over limit !:over margin

Note: Measurement=Reading Level+Correc Factor. Factor=(LISN or ISN or PLC or Current Probe)Factor+Cable

Frequency Range	: 30MHz~1000MHz
Test Mode	: Full Load, Half Load, Empty Load
Test Results	: PASS
Note:	<p>1. The test results are listed in next pages.</p> <p>2. All test modes has been tested, this report only reflected the worst mode. (Full Load)</p> <p>3. If the limits for the measurement with the average detector are met when using a receiver with a peak detector, the test unit shall be deemed to meet both limits and the measurement with the quasi-peak detector need not be carried out.</p>

Frequency Range	: Above 1GHz		
EUT	: /	Test Date	: /
M/N	: /	Temperature	: /
Test Engineer	: /	Humidity	: /
Test Mode	: /		
Test Results	: N/A		
Note:	<p>1. The highest frequency of the internal sources of the EUT is less than 108 MHz, the measurement shall only be made up to 1 GHz. So the frequency rang above 1GHz radiation test not applicable.</p>		

30MHz-1GHz

Pol	Vertical
-----	----------

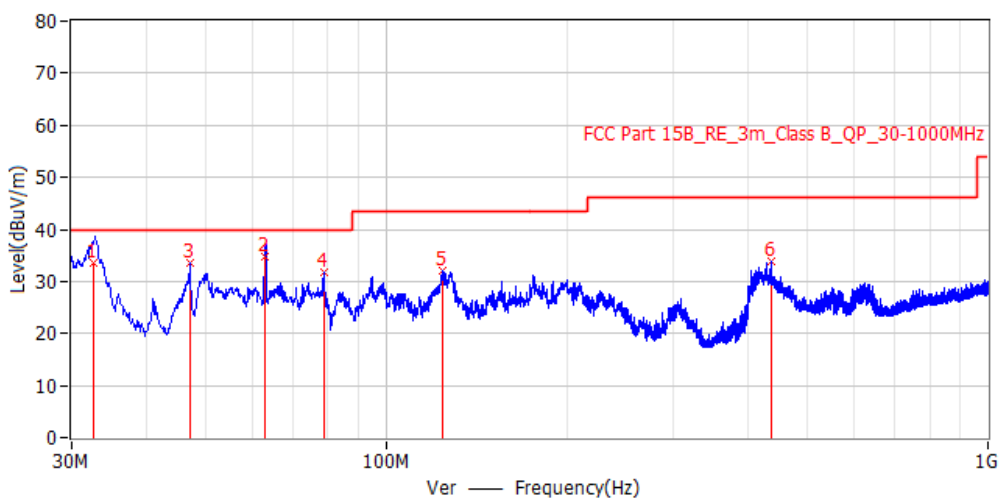

No.	Frequency	Level dBuV/m	Factor dB/m	Limit dBuV/m	Margin dB	Detector	Polar	Height cm	Angle deg
1	32.666 MHz	33.6	16.7	40.0	-6.4	QP	Ver	100.0	112.0
2	62.796 MHz	34.9	16.2	40.0	-5.1	QP	Ver	100.0	252.0
3*	47.218 MHz	33.5	17.3	40.0	-6.5	PK	Ver	100.0	27.0
4*	78.743 MHz	31.7	13.1	40.0	-8.3	PK	Ver	100.0	123.0
5*	124.211 MHz	32.0	15.6	43.5	-11.5	PK	Ver	100.0	139.0
6*	435.702 MHz	33.9	19.0	46.0	-12.1	PK	Ver	100.0	162.0

Pol	Horizontal
-----	------------

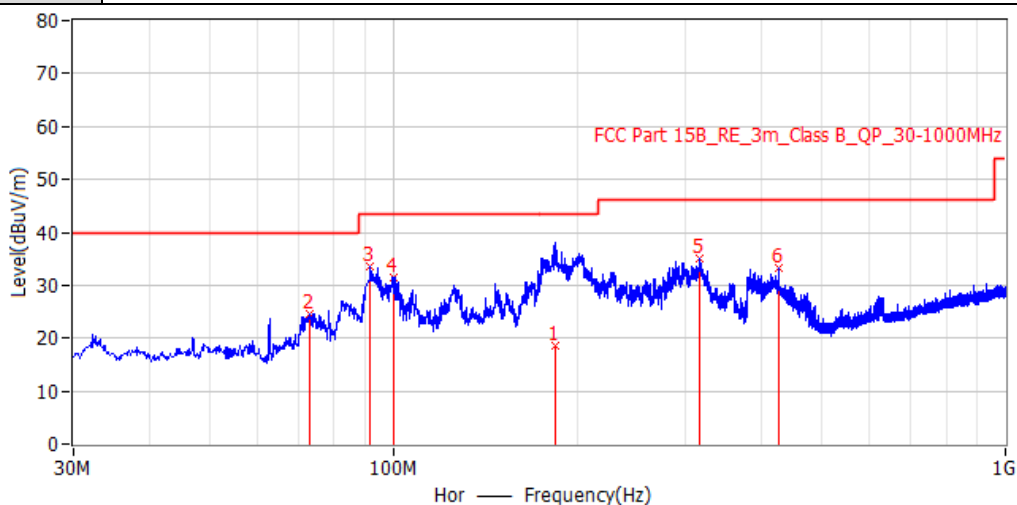

No.	Frequency	Level dBuV/m	Factor dB/m	Limit dBuV/m	Margin dB	Detector	Polar	Height cm	Angle deg
1	183.665 MHz	18.6	14.9	43.5	-24.9	QP	Hor	100.0	325.0
2*	73.044 MHz	24.7	14.4	40.0	-15.3	PK	Hor	100.0	246.0
3*	91.595 MHz	33.6	12.9	43.5	-9.9	PK	Hor	200.0	212.0
4*	99.840 MHz	31.5	13.5	43.5	-12.0	PK	Hor	200.0	253.0
5*	316.150 MHz	35.1	16.9	46.0	-10.9	PK	Hor	100.0	281.0
6*	426.245 MHz	33.2	18.8	46.0	-12.8	PK	Hor	100.0	127.0

3.3. Test Specification

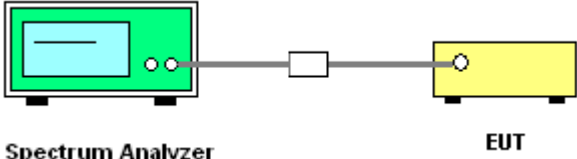
Test Requirement:	FCC Part15 C Section 15.215(c)
Test Method:	ANSI C63.10: 2013
Limit:	N/A
Test Procedure:	<ol style="list-style-type: none"> 1. According to the follow Test-setup, keep the relative position between the artificial antenna and the EUT. 2. Set to the maximum power setting and enable the EUT transmit continuously. 3. Use the following spectrum analyzer settings for 20dB Bandwidth measurement. Span = approximately 2 to 3 times the 20 dB bandwidth, centered on a hopping channel; RBW \geq 1% of the 20 dB bandwidth; VBW \geq RBW; Sweep = auto; Detector function = peak; Trace = max hold. 4. Measure and record the results in the test report.
Test setup:	 <p>The diagram illustrates the test setup. On the left is a Spectrum Analyzer, represented by a green box with a blue screen and two small circles. A cable connects it to a small white rectangular component, which is then connected to a yellow box labeled 'EUT' (Equipment Under Test). Below the Spectrum Analyzer is the text 'Spectrum Analyzer' and below the EUT is the text 'EUT'.</p>
Test Mode:	Refer to section 4.1 for details
Test results:	PASS

3.3.1. Test Data

Frequency(KHz)	20dB Occupy Bandwidth (kHz)	Limit (kHz)	Conclusion
145	3.549	---	PASS

Test plots as follows:

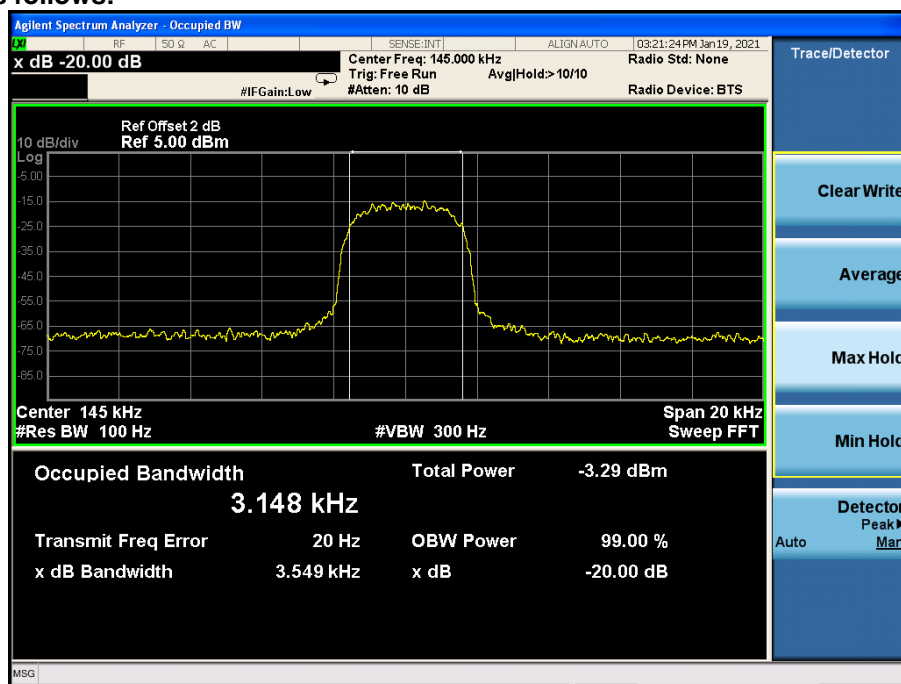

4. Photos of Test Setup

Radiated Emission

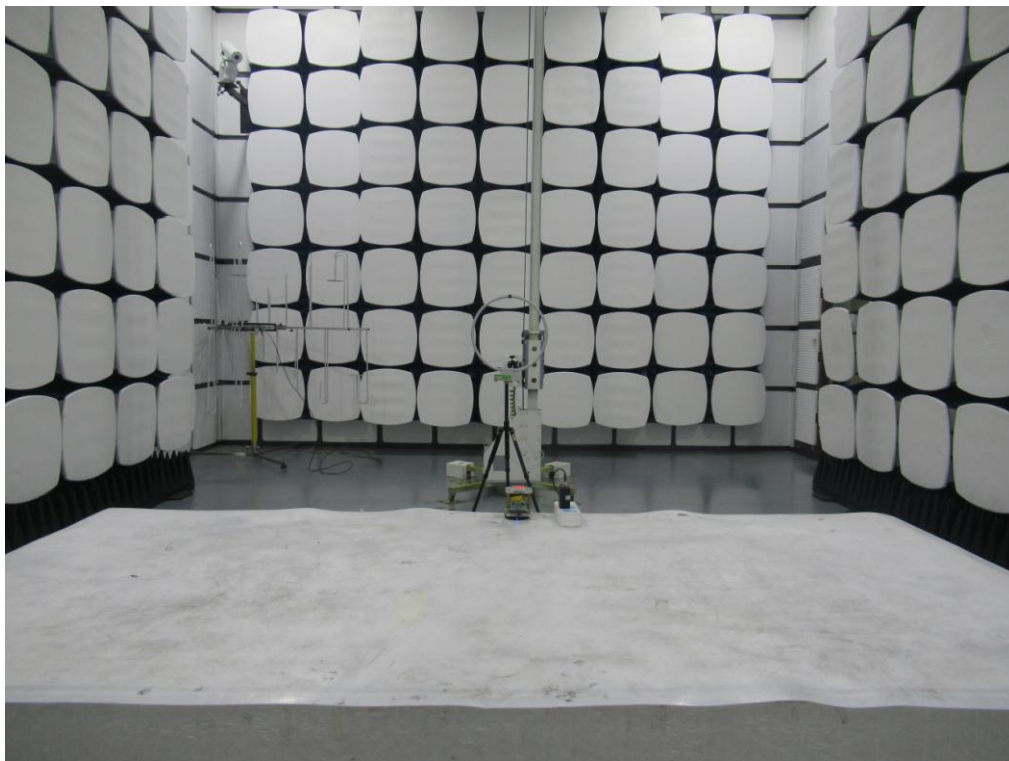
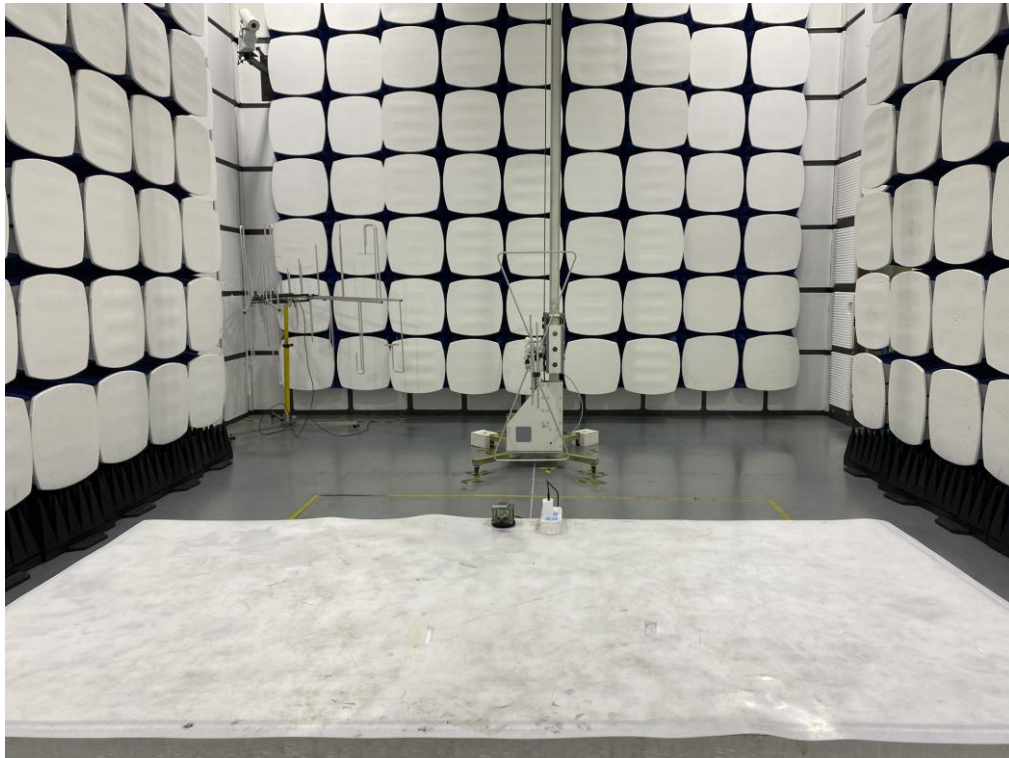

Conducted Emission



5. Photographs of EUT





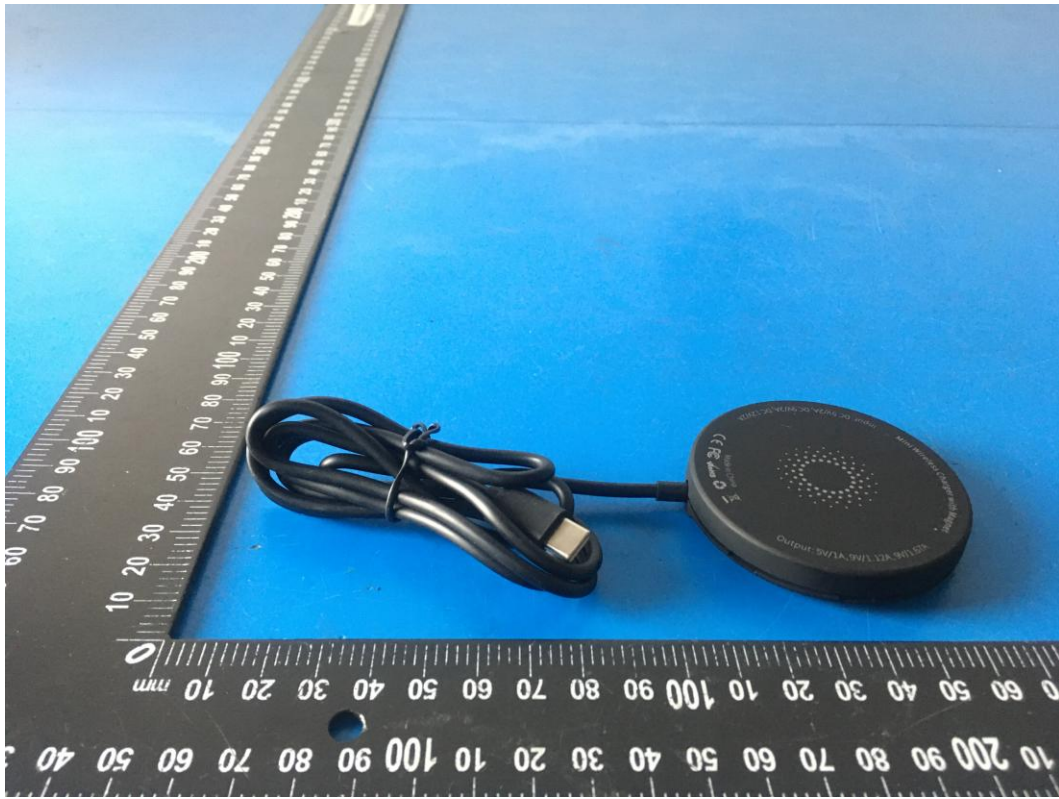

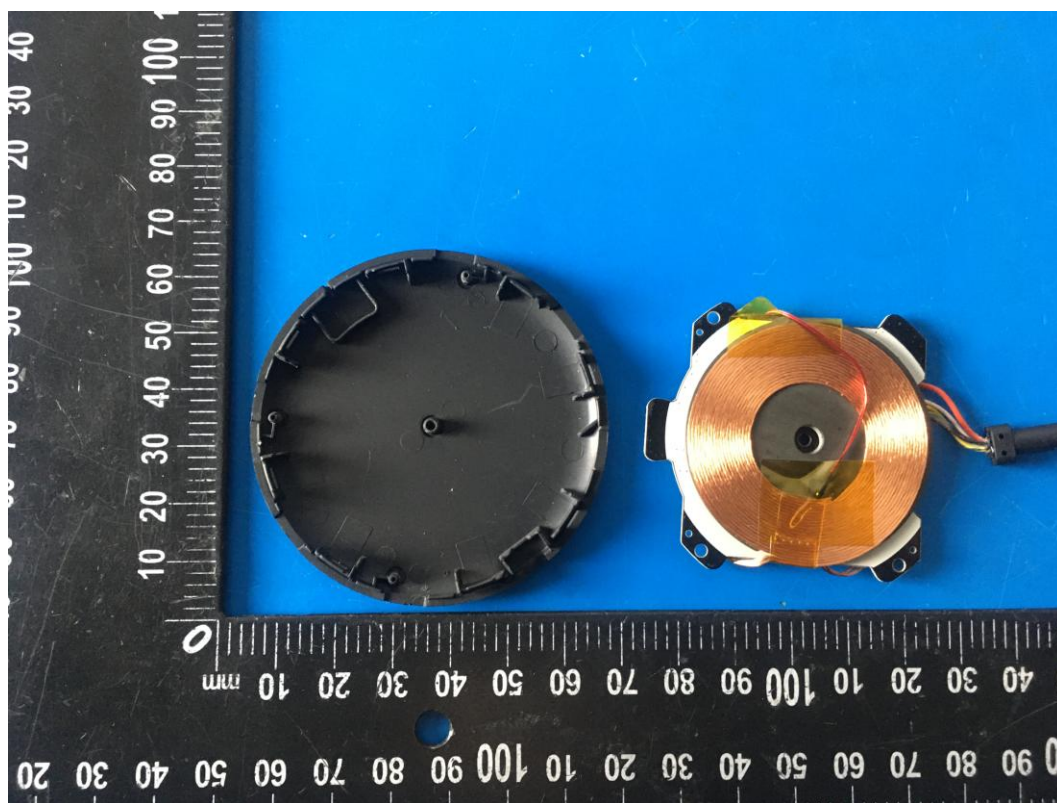
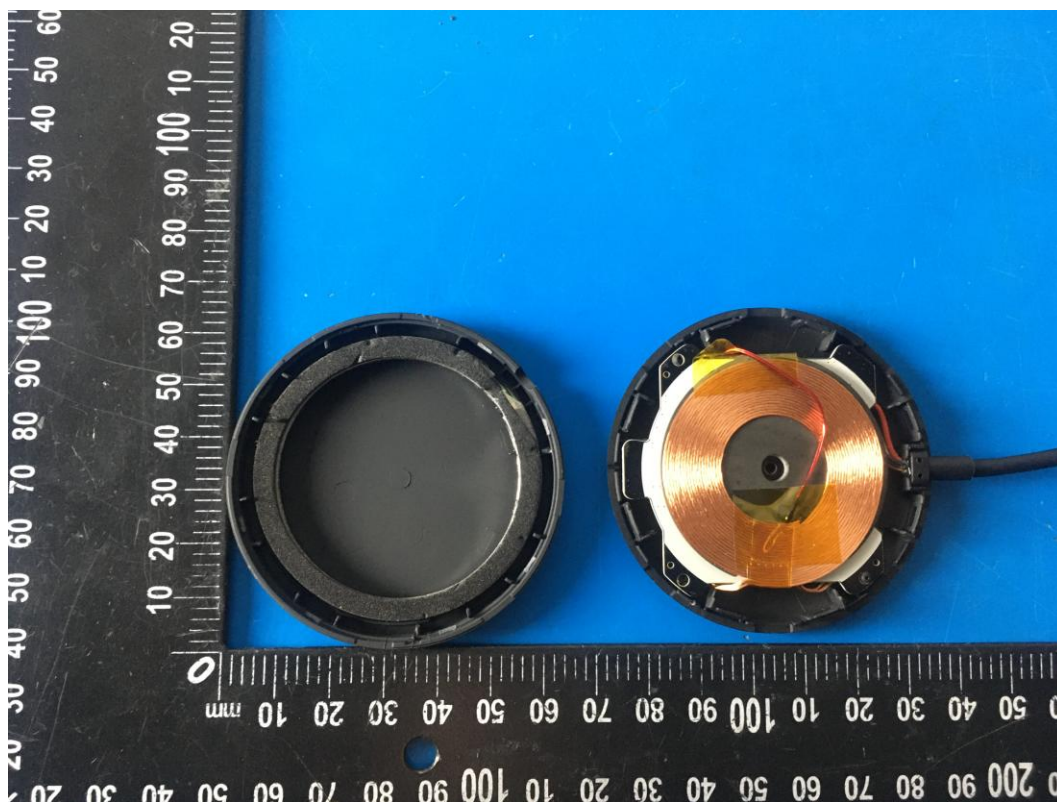

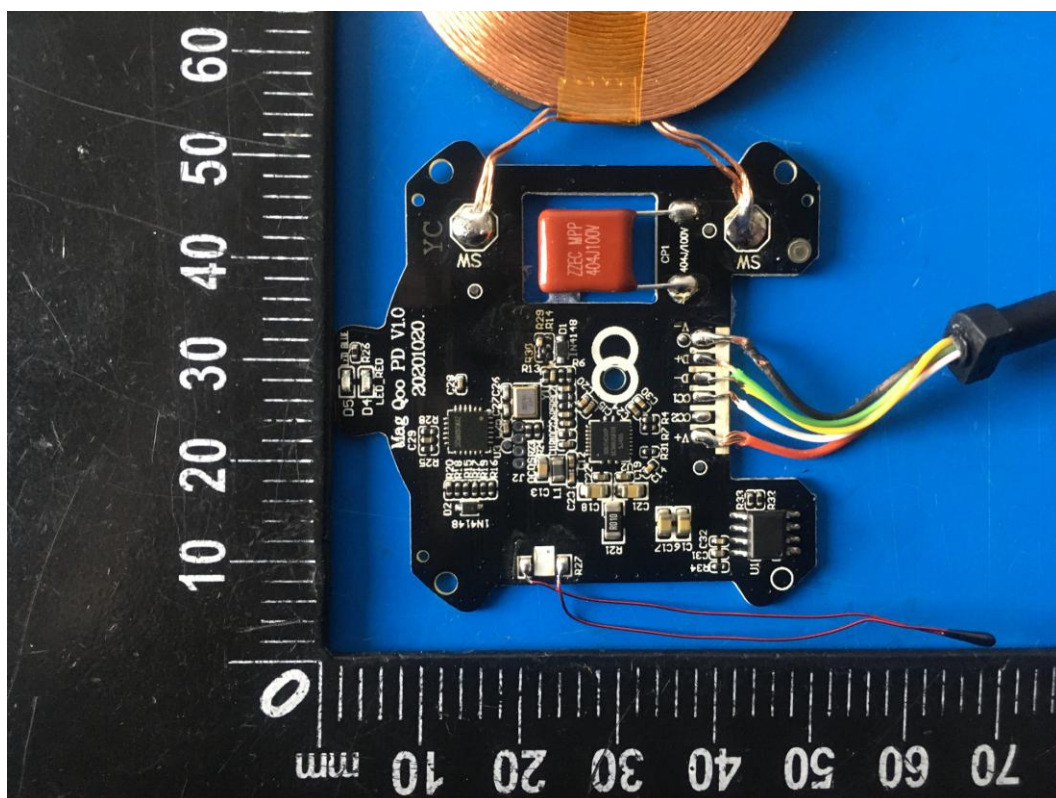
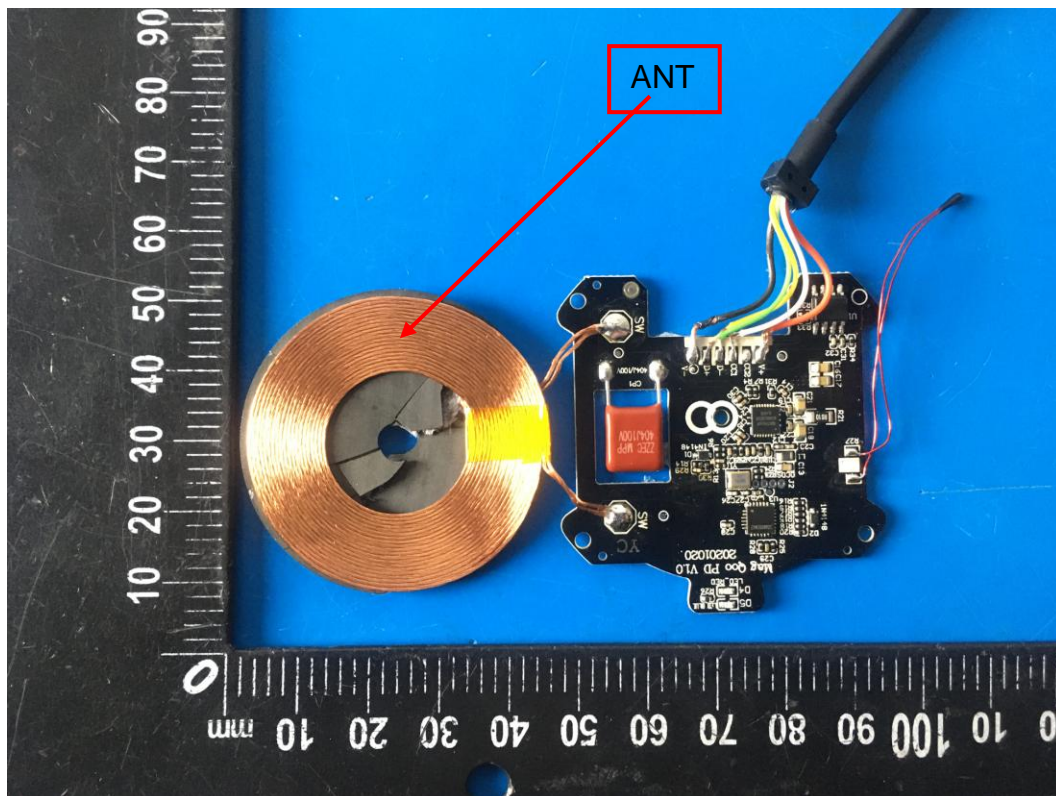

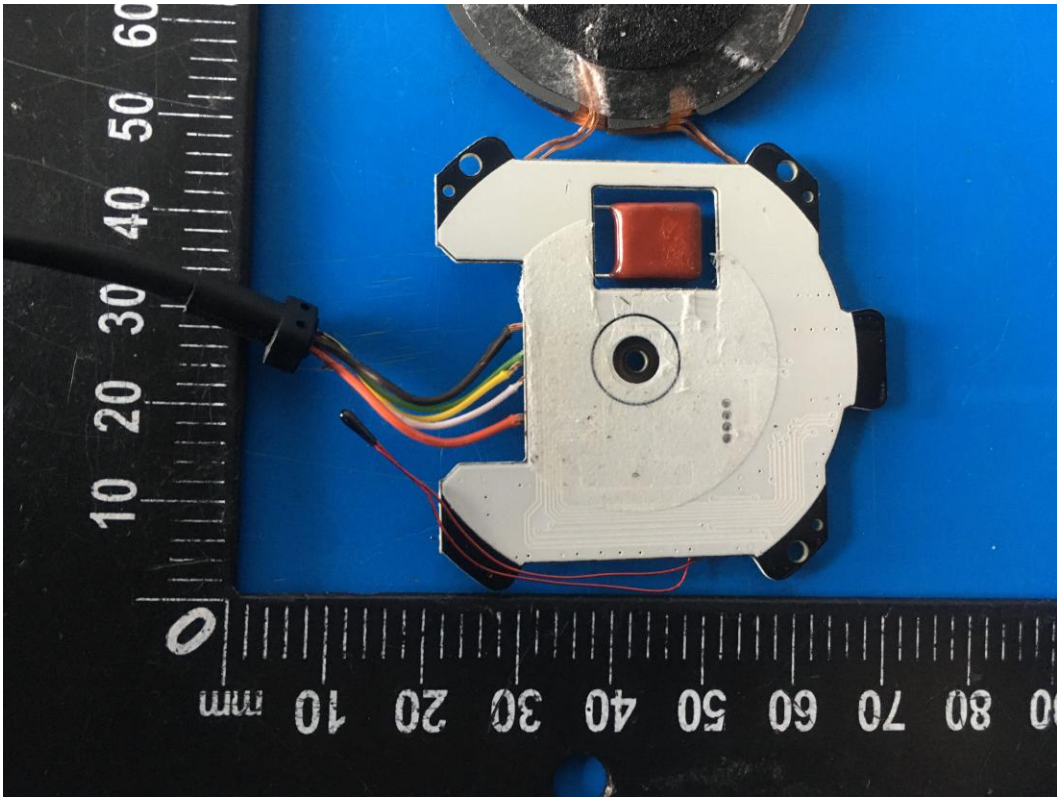

-----End-----