

Wireless Magnetic Vehicle Charger Manual

Model: Maghold C02

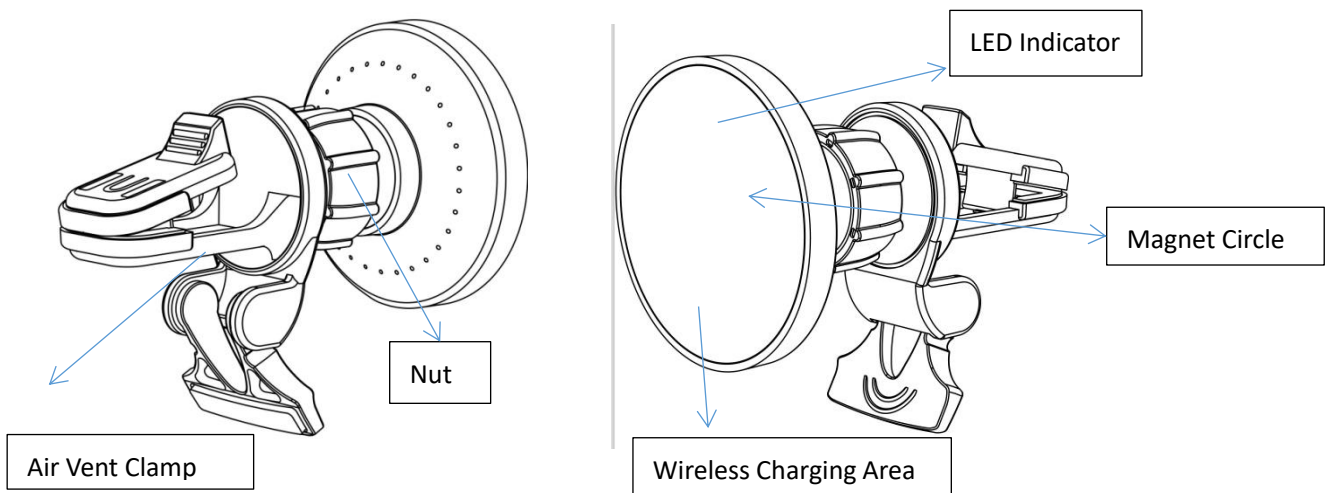

Note: For best performance and safety, please read this manual carefully before using the product.



1. Connect the Air Vent Clamp to the Devices;

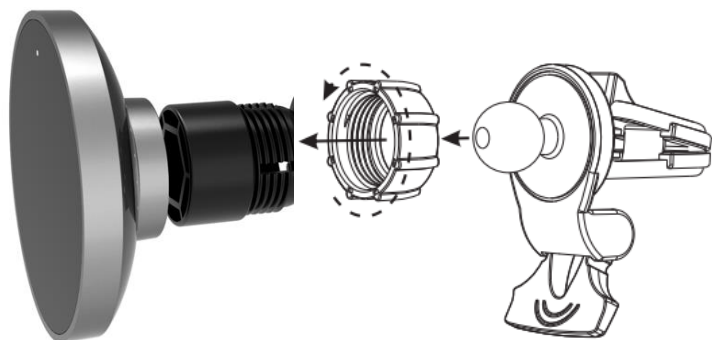

- .Unscrew the nut
- .Place the nut around ball head,insert into socket
- .Tighten nut clockwise

2.Attach clamp to the car vent

Press the button to unlock the air vent clamp; entry and release to grip the air vent

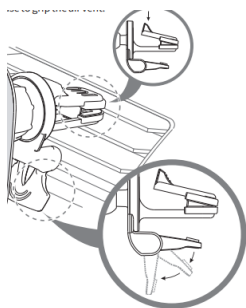

3.Connect power to the charger

Use the USB-C to C cable packed in the box to connect the device and the car charger.

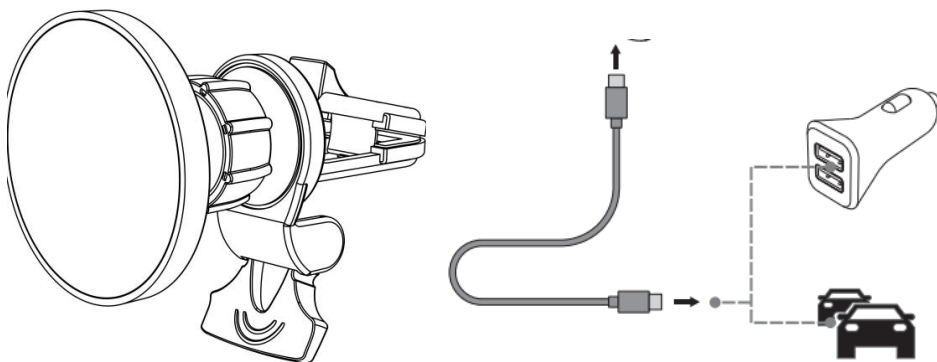

Tips:When using this product, please make sure that the product is connected to the power.To achieve fast charging,QC2.0/3.0 car charger is required.

4.Charging your iPhone

Please fit the product with the back of your iPhone, it will charge your iPhone automatically via the built-in magnetic wireless charger,Max Output to be 15W.



Note: Under normal charging conditions, the charger and mobile phone could be slightly hot; the temperature may rise if the mobile phone is working while charging (such as playing video). Please stop charging your phone when the charger is over-heating. Our product will automatically stop charging when over-heating. Please try it again when it's cooling down

5. Indicators Status

Standby:White Light On

WirelessCharging:White Light Breathing

Fully Charged:White Light Breathing

FOD: Red & White Blinks

Overtemp.Protection: Red Light Blinks

Over Voltage Protection:Red Light Blinks

Short Circuit Protection:Red Light Blinks

Over Current Protection:Red Light Blinks

Precautions

Please carefully handle your charger and accessories,the following recommendations will help you effectively use the warranty service.

Please keep the equipment dry.Rain,moisture and various liquidmay contain minerals that will corrode the circuit. If the equipment is wet, please dry the product as soon as possible or use a soft clothto wipe it clean.losing the data stored due to emagnetization.

When charging,please select the regular 5V/2A,9V/2A chargers.Do not use any damaged chargers.

Please do not attempt to charge the equipment with exposed or case broken,and do not charge the equipment that are incompatible with this product.

Do not storethe equipment in a cold place. Otherwise, if temperature rises to normal temperature, moisture will pent up inside it and damage the electric appliance.

Do not attempt to open the equipment, unauthorized dis-assembly or modification will damage equipment or related wireless charging functions.

Donot throw, apor shake the equipment; rough handling of the equipment will damage the internal circuit board and the mechanical structure.

Use the clean and moist soft cloth to clean the surface of the equipment.Donot use or store the equipment in dusty or dirty places.

Some components of this product are magnetic and metal materials may be adsorbed onto this product. Please do not use bank cards, credit cards or any other items with magnetic near the product so as to avoid losing the data stored due to demagnetization.

Fits Below Supports(NotIncluded) Ball Diameter:16.8±0.3mm

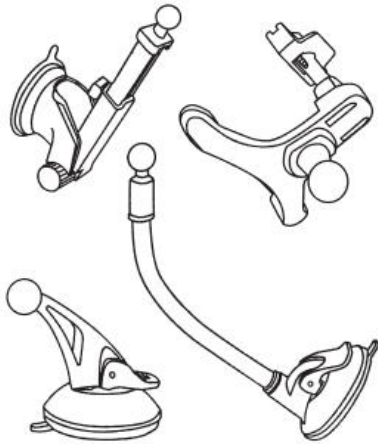

Specifications:

Input:5V 2A, 9V 2A, 12V 2A

Wireless Output:5W, 7.5W,10W,15W

Cable Length: 1M USB C TO C CABLE

Dimension:60*2.5mm

Wha's Inthebox:



User manual ×1



Air Vent Clamp ×1



USB-A to USB-C Cable ×1

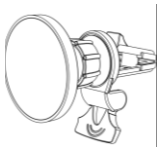

Charger X 1

This equipment has been tested and found to comply with the limits for a Class B digital device, pursuant to part 15 of the FCC Rules. These limits are designed to provide reasonable protection against harmful interference in a residential installation. This equipment generates, uses and can radiate radio frequency energy and, if not installed and used in accordance with the instructions, may cause harmful interference to radio communications. However, there is no guarantee that interference will not occur in a particular installation. If this equipment does cause harmful interference to radio or television reception, which can be determined by turning the equipment off and on, the user is encouraged to try to correct the interference by one or more of the following measures:

- Reorient or relocate the receiving antenna.
- Increase the separation between the equipment and receiver.
- Connect the equipment into an outlet on a circuit different from that to which the receiver is connected.
- Consult the dealer or an experienced radio/TV technician for help.

Caution: Any changes or modifications to this device not explicitly approved by manufacturer could void your authority to operate this equipment.

This device complies with part 15 of the FCC Rules. Operation is subject to the following two conditions: (1) This device may not cause harmful interference, and (2) this device must accept any interference received, including interference that may cause undesired operation.

The device has been evaluated to meet general RF exposure requirement.