



FCC TEST REPORT
FCC ID: 2AP2N-MAG5000W

On Behalf of

Shenzhen Esorun Technology Co., LTD

Magnetic Wireless Power Bank

Model No.: Mag5000W

Prepared for : Shenzhen Esorun Technology Co., LTD
Address : 101, Dormitory Building, No. 1215, Guihua Community Guanguang
Road, Guanlan Street, Longhua District, Shenzhen, China

Prepared By : Shenzhen Alpha Product Testing Co., Ltd.
Address : Building i, No.2, Lixin Road, Fuyong Street, Bao'an District,
518103, Shenzhen, Guangdong, China

Report Number : A2106137-C01-R03
Date of Receipt : June 22, 2021
Date of Test : June 22, 2021–July 15, 2021
Date of Report : July 15, 2021
Version Number : V0

TABLE OF CONTENTS

1. Test Result Summary	5
2. EUT Description.....	6
2.1. Description of Device (EUT).....	6
2.2. Accessories of Device (EUT)	8
2.3. Tested Supporting System Details.....	8
2.4. Block Diagram of Connection between EUT and Simulators	8
2.5. Description of Test Modes	8
2.6. Test Conditions	8
2.7. Test Facility.....	9
2.8. Measurement Uncertainty	9
3. Test Results and Measurement Data	10
3.1. RF Exposure Test.....	10
4. Photos of test setup	14
5. Photographs of EUT	18

TEST REPORT DECLARATION

Applicant : Shenzhen Esorun Technology Co., LTD
 Address : 101, Dormitory Building, No. 1215, Guihua Community Guanguang Road, Guanlan Street, Longhua District, Shenzhen, China
 Manufacturer : Shenzhen Esorun Technology Co., LTD
 Address : 101, Dormitory Building, No. 1215, Guihua Community Guanguang Road, Guanlan Street, Longhua District, Shenzhen, China
 EUT Description : Magnetic Wireless Power Bank
 (A) Model No. : Mag5000W
 (B) Trademark : **ESORUN**

Measurement Standard Used:

FCC CFR Title 47 Part 15 Subpart C

FCC KDB 680106 D01 RF Exposure Wireless Charging App v03r01

The device described above is tested by Shenzhen Alpha Product Testing Co., Ltd. to determine the maximum emission levels emanating from the device and the severe levels of the device can endure and its performance criterion. The test results are contained in this test report and Shenzhen Alpha Product Testing Co., Ltd. is assumed full responsibility for the accuracy and completeness test. Also, this report shows that the EUT is technically compliant with the KDB 680106 D01 requirements.

This report applies to above tested sample only. This report shall not be reproduced in parts without written approval of Shenzhen Alpha Product Testing Co., Ltd.

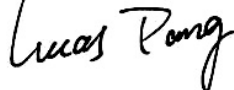
Tested by (name + signature).....: Lucas Pang
 Project Engineer 

Approved by (name + signature).....: Simple Guan
 Project Manager 

Date of issue..... : July 15, 2021

Revision History

Revision	Issue Date	Revisions	Revised By
V0	July 15, 2021	Initial released Issue	Lucas Pang

1. Test Result Summary

Requirement	CFR 47 Section	Result
RF EXPOSURE	§1.1307(b)(1) & KDB680106	PASS

Note:

1. *PASS: Test item meets the requirement.*
2. *Fail: Test item does not meet the requirement.*
3. *N/A: Test case does not apply to the test object.*
4. *The test result judgment is decided by the limit of test standard.*

2. EUT Description

2.1. Description of Device (EUT)

EUT Name	:	Magnetic Wireless Power Bank
Model No.	:	Mag5000W
DIFF.	:	N/A
Trademark	:	ESORUN
Power supply	:	Micro Input : 5V =2.0A Type-C Input : 5V =2.0A USB Output: 5V=2.0A Wireless Output : 5V =1.0A(5W) Total output power: Max 10W
Operation frequency	:	115~205KHz
Modulation	:	MSK
Antenna Type	:	Coil Antenna, Maximum Gain is 0dBi (This value is supplied by applicant).
Software version	:	V1.0
Hardware version	:	V1.0
Intend use environment	:	Residential, commercial and light industrial environment

Conditions requirement	Answers
Power transfer frequency is less than 1 MHz.	After measuring the product the transfer frequency is 0.115-0.205MHz
Output power from each primary coil is less than or equal to 15 watts.	After measuring the product the each primary coil power is 5 watts
The system may consist of more than one source primary coils, charging one or more clients. If more than one primary coils present, the coil pairs may be powered on at the same time.	The transfer system includes only single primary.
Client device is placed directly in contact with the transmitter.	Client device is placed directly in contact with the transmitter.
Mobile exposure conditions only (portable exposure conditions are not covered by this exclusion).	Can be used as a fixed device or as a portable device
The aggregate H-field strengths anywhere at or beyond 15 cm surrounding the device, and 20 cm away from the surface from all coils that by design can simultaneously transmit, and while those coils are simultaneously energized, are demonstrated to be less than 50% of the applicable MPE limit.	After measuring the product the Max H-field Strength is 0.812A/m Far less than 50% of the MPE limit; the Max E-field Strength is 2.099 V/m Far less than 50% of the MPE limit.

2.2. Accessories of Device (EUT)

Accessories1 : Cable
 Manufacturer : Shenzhen Esorun Technology Co., LTD
 Model : /
 Ratings : /

2.3. Tested Supporting System Details

No.	Description	Manufacturer	Model	Serial Number	Certification
1	Wireless load	--	--	--	--
2	Adapter	--	XIAOMI	--	--

2.4. Block Diagram of Connection between EUT and Simulators

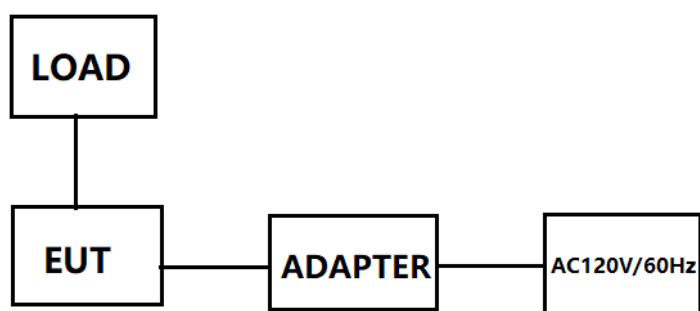

2.5. Description of Test Modes

Channel	Frequency (KHz)
1	115

2.6. Test Conditions

Items	Required	Actual
Temperature range:	15-35°C	24°C
Humidity range:	25-75%	56%
Pressure range:	86-106kPa	98kPa

2.7. Test Facility

Shenzhen Alpha Product Testing Co., Ltd

Building i, No.2, Lixin Road, Fuyong Street, Bao'an District, 518103, Shenzhen, Guangdong, China

June 21, 2018 File on Federal Communication Commission

Registration Number: 293961

July 15, 2019 Certificated by IC

Registration Number: CN0085

2.8. Measurement Uncertainty

(95% confidence levels, $k=2$)

Item	Uncertainty
Uncertainty for H-Field	2.39dB
Uncertainty for E-Field	2.45dB
Uncertainty for conducted RF Power	0.65dB
Uncertainty for temperature	0.2°C
Uncertainty for humidity	1%
Uncertainty for DC and low frequency voltages	0.06%

3. Test Results and Measurement Data

3.1. RF Exposure Test

3.1.1. Test Specification

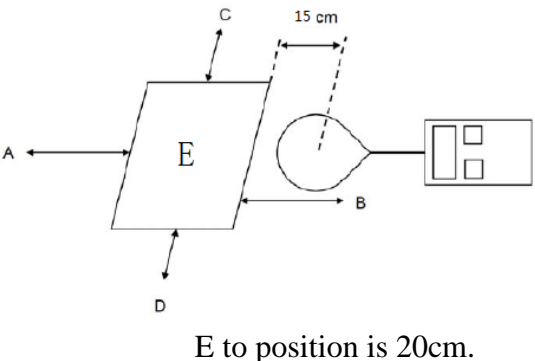
Test Requirement:	FCC Rules and Regulations KDB680106
Test Method:	§1.1307(b)(1) & KDB680106
Limits:	According to §1.1307(b)(1), systems operating under the provisions of this section shall be operated in a manner that ensures that the public is not exposed to radio frequency energy level in excess of the Commission's guidelines. According to §1.1310 and §2.1093 RF exposure is calculated. According KDB680106 D01v03r01: RF Exposure Wireless Charging.
Test Setup:	 <p>E to position is 20cm.</p>
Test Mode:	Charging + Transmitting Mode
Test Procedure:	<ol style="list-style-type: none"> 1. The RF exposure test was performed on 80cm insulated table in anechoic chamber. 2. The measurement probe was placed at test distance (15cm) which is between the edge of the charger and the geometric centre of probe. 3. The highest emission level was recorded and compared with limit as soon as measurement of each points (A, B, C, D, E) were completed. 4. The EUT were measured according to the dictates of KDB 680106D01v03r01.
Test Result:	PASS

3.1.2. Test Instruments

Item	Equipment	Manufacturer	Model No.	Serial No.	Last Cal.	Cal. Interval
1	Exposure Level Tester	narda	ELT-400	N-0231	2020.09.02	1 Year
2	Magnetic field probe 100cm2	narda	ELT probe 100cm2	M0675	2020.09.02	1 Year
3	Isotropic Electric Field Probe	narda	EP-601	511WX60706	2020.09.02	1 Year

3.1.3. Test data

For Full load mode:

E-Field Strength at 0 cm for position A,B,C,D,E from the edges surrounding the EUT (V/m)

Frequency Range (MHz)	Test Position A	Test Position B	Test Position C	Test Position D	Test Position E	Limit (50%) (V/m)	Limits Test (V/m)
0.115-0.205	2.099	2.032	1.990	2.035	1.950	307	614

E-Field Strength at 15 cm for position A,B,C,D 20cm for position E from the edges surrounding the EUT (V/m)

Frequency Range (MHz)	Test Position A	Test Position B	Test Position C	Test Position D	Test Position E	Limit (50%) (V/m)	Limits Test (V/m)
0.115-0.205	1.613	1.467	1.534	1.498	1.449	307	614

H-Filed Strength at 0 cm for position A,B,C,D,E from the edges surrounding the EUT (A/m)

Frequency Range (MHz)	Test Position A	Test Position B	Test Position C	Test Position D	Test Position E	Limit (50%) (A/m)	Limits Test (A/m)
0.115-0.205	0.812	0.781	0.781	0.766	0.742	0.815	1.63

H-Filed Strength at 15 cm for position A,B,C,D 20cm for position E from the edges surrounding the EUT (A/m)

Frequency Range (MHz)	Test Position A	Test Position B	Test Position C	Test Position D	Test Position E	Limit (50%) (A/m)	Limits Test (A/m)
0.115-0.205	0.805	0.724	0.720	0.706	0.726	0.815	1.63

For Half load mode:

E-Field Strength at 0 cm for position A,B,C,D,E from the edges surrounding the EUT (V/m)

Frequency Range (MHz)	Test Position A	Test Position B	Test Position C	Test Position D	Test Position E	Limit (50%) (V/m)	Limits Test (V/m)
0.115-0.205	1.715	1.624	1.636	1.559	1.629	307	614

E-Field Strength at 15 cm for position A,B,C,D 20cm for position E from the edges surrounding the EUT (V/m)

Frequency Range (MHz)	Test Position A	Test Position B	Test Position C	Test Position D	Test Position E	Limit (50%) (V/m)	Limits Test (V/m)
0.115-0.205	1.481	1.418	1.448	1.335	1.345	307	614

H-Filed Strength at 0 cm for position A,B,C,D,E from the edges surrounding the EUT (A/m)

Frequency Range (MHz)	Test Position A	Test Position B	Test Position C	Test Position D	Test Position E	Limit (50%) (A/m)	Limits Test (A/m)
0.115-0.205	0.808	0.763	0.769	0.730	0.765	0.815	1.63

H-Filed Strength at 15 cm for position A,B,C,D 20cm for position E from the edges surrounding the EUT (A/m)

Frequency Range (MHz)	Test Position A	Test Position B	Test Position C	Test Position D	Test Position E	Limit (50%) (A/m)	Limits Test (A/m)
0.115-0.205	0.691	0.660	0.674	0.618	0.623	0.815	1.63

For Null load mode:

E-Field Strength at 0 cm for position A,B,C,D,E from the edges surrounding the EUT (V/m)

Frequency Range (MHz)	Test Position A	Test Position B	Test Position C	Test Position D	Test Position E	Limit (50%) (V/m)	Limits Test (V/m)
0.115-0.205	1.613	1.533	1.506	1.532	1.553	307	614

E-Field Strength at 15 cm for position A,B,C,D 20cm for position E from the edges surrounding the EUT (V/m)

Frequency Range (MHz)	Test Position A	Test Position B	Test Position C	Test Position D	Test Position E	Limit (50%) (V/m)	Limits Test (V/m)
0.115-0.205	1.335	1.163	1.325	1.149	1.323	307	614

H-Filed Strength at 0 cm for position A,B,C,D,E from the edges surrounding the EUT (A/m)

Frequency Range (MHz)	Test Position A	Test Position B	Test Position C	Test Position D	Test Position E	Limit (50%) (A/m)	Limits Test (A/m)
0.115-0.205	0.757	0.717	0.704	0.717	0.727	0.815	1.63

H-Filed Strength at 15 cm for position A,B,C,D 20cm for position E from the edges surrounding the EUT (A/m)

Frequency Range (MHz)	Test Position A	Test Position B	Test Position C	Test Position D	Test Position E	Limit (50%) (A/m)	Limits Test (A/m)
0.115-0.205	0.618	0.532	0.613	0.524	0.612	0.815	1.63

4. Photos of test setup

For Full load mode



0cm

For No load mode



0cm

For Full load mode



15cm

For No load mode



15cm

For Full load mode



0cm

For No load mode



0cm

For Full load mode



15cm

For No load mode



15cm

5. Photographs of EUT

Refer to test report A2106137-C01-R02.

-----End-----