

承 認 書

SPECIFICATION FOR APPROVAL

客 戶:
CUSTOMER: 深圳市一讯达科技有限公司

客 戶 料 號:
CUST P/N: 10-0110-0239

松 島 料 號:
FINE P/N: G511-6.3UH 单线圈 0.08*105P*10TS

產 品 型 號:
DESC: Φ 50MMX5.0MMX1.0MM

日 期:
DATE: 2022/01/21

版 本:
Version: A.0

擬制 PREPARED BY	審核 CHECKED BY	批准 APPROVED BY	客戶承認 CUSTOMER APPROVE
宁元安	黄燕铭	黄锦华	

Manufacturer: Dongguan Xilian Gancheng Technology Co., Ltd

Address: 8th Floor, Building 2, Sanjia High tech Industrial Park, No. 123

Junfa Road, Dongkeng Town, Dongguan City

TEL: 0769-82989159

FAX: 0769-8298915

E-mail: aming198204@163.com

SPECIFICATION

產品型號: DESC	Φ20.5x43-6.3uH-0.08x105-40mm	版本 Rev: A.0	客戶 CUST: 客戶料号 CUST P/N:	XXX
---------------	------------------------------	----------------	----------------------------	-----

一、尺寸 DIMENSION:(mm)

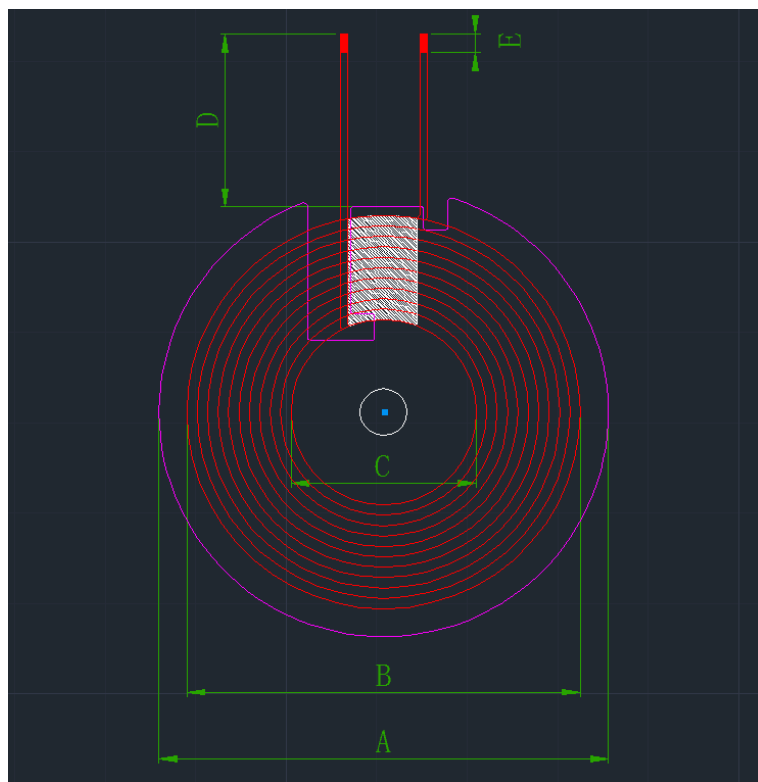

A	50.0±1
B	44±1.5
C	20.5±0.5
D	30±2
E	4±2

注:

- 交叉出线;
- 出线位置缠 8mm(ref)宽度高温胶纸 1-2Ts;
- 线圈贴圆形硬磁片带槽,磁片尺寸 50±1mm,内孔 5.3mm,厚度为 1.0±0.2mm。

二、原理图 SCHEMATIC DIAGRAM:



三、绕线参数 Winding Specification:

序号 NO.	端子 TERMINAL	线径 WIRE	圈数 Turns	绕线方向 Winding Direction
1	S F	丝包线 0.08*105P	10Ts	CCW

四、电气特性 ELECTRICAL CHARACTERISTICS:

温度 TEMPERATURE:25±10℃, 湿度 RELATIVE HUMIDITY:65±20%

序号 NO.	项目 ITEM	端子 TERMINAL	标准 SPECIFICATION	测试条件 TEST FREQUENCY	测试仪器 TEST EQUIPMENTS
1	IND.	S-F	3.8uH ±20%单独线圈	100KHz/1.0V	LCZ METER 1062B
2	IND.	S-F	6.3uH ±10%加磁片	100KHz/1.0V	LCZ METER 1062B
3	DCR	S-F	≤53mΩ	100KHz/1.0V	LCZ METER 502B
4	Q 值	S-F	≥75mΩ	100KHz/1.0V	LCZ METER 502B

擬制/日期 PREPARED BY/DATE	審核/日期 CHECKED BY/DATE
黃燕銘 2022/1/21	黃錦華 2022/1/21

Antenna Gain: Only radiated measurements are used to show compliance with FCC limits for fundamental and spurious emissions.
