

Honeywell

LED INDOOR/OUTDOOR MOTION SENSOR LIGHTS

MODEL: A04HB013C-HG ASSEMBLY AND INSTALLATION INSTRUCTIONS

5 YEAR LIMITED WARRANTY

You should read all of the instructions before attempting to use this product.

Sky Rich Star Limited (SRS) warrants this product against defects in material or workmanship for a period of five (5) years from the date of original purchase. SRS agrees to either repair the product or replace it, at the sole discretion of SRS. Only the original purchaser of this product is extended this warranty. No warranty work will be provided under this warranty without purchaser's receipt or other proof of the date of original purchase acceptable to SRS. Proof of the date of purchase must be provided to SRS if the product is returned. Purchasing this product from a third party vendor negates all warranties (expressed or implied) in this warranty.

The warranty does not apply to the following terms/conditions:

- 1.) Acts of God.
 - 2.) Products that have been subjected to unauthorized repair, opened, disassembled, and/or otherwise modified.
 - 3.) Products used not in accordance with directions.
 - 4.) Damages exceeding the total cost of product.
 - 5.) Plastic or plastic shades.
 - 6.) The finish of any portion of the product (i.e. surface scratches, weathering, corrosion, discoloration of brass components, as this is considered normal wear and tear).
 - 7.) Damages caused by shipping, improper handling, accident, misuse or abuse. SRS is not responsible for damage of merchandise in transit. Repaired or replaced products shall be subject to the terms of this warranty and are inspected prior to return shipment. Damages that are incurred during transit should be reported at once to the carrier and a claim should be filed with them.
 - 8.) warranty does not cover replacement of Alkaline batteries included with this product.
- SRS SHALL NOT BE LIABLE FOR INCIDENTAL, SPECIAL OR CONSEQUENTIAL DAMAGES RESULTING FROM THE USE OF THE PRODUCT OR ARISING OUT OF ANY BREACH OF THIS WARRANTY. ALL IMPLIED WARRANTIES, IF ANY, INCLUDING IMPLIED WARRANTIES OF MERCHANTABILITY AND FITNESS FOR A PARTICULAR PURPOSE, ARE LIMITED IN CURATION TO THE DURATION OF THIS EXPRESS WARRANTY. Some states do not allow the exclusion or limitation of incidental or consequential damages, or limitations on how long an implied warranty lasts, so the above exclusions or limitations may not apply to you. No other warranty, written or verbal, will be honored for this product. This warranty grants you specific legal rights, you may also have other rights which vary from state to state. There are no other warranties except those stated above.

Thank You

We appreciate your purchase of this SRS product.

SRS has made every effort to supply a quality product that insures long, trouble free service. In the event that you have any type of problems with this product and require a return address or for any other assistance please call our

Toll Free Number 1-877-723-0723

8:00 A.M. - 5:00 P.M. Central Time, Monday - Friday

Email us at: customerservice@idctexas.com

You will need the following information:

Model/Item Number of Product, Receipt, and Date of Purchase

All drawings and text are © copyright of SRS • Printed in China

SKY RICH STAR LIMITED

UNIT E, 10/F, WORLDWIDE CENTRE, 123 TUNG CHAU STREET,
TAI KOK TSUI, KL, HONG KONG

Toll-free: 1-877-723-0723

© 2019 Sky Rich Star Limited, all rights reserved.

The Honeywell Trademark is used under license from Honeywell International Inc.

Honeywell International Inc. makes no representations or warranties with respect to this product.

This product is manufactured for Sky Rich Star Limited.

INSTRUCTIONS

Tools Required



Hardware Included

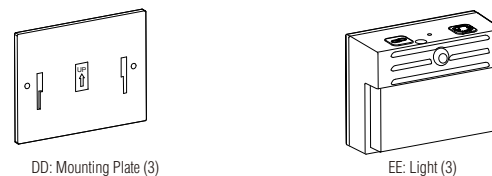
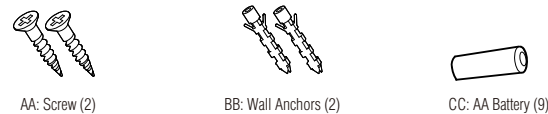

Marking the Location

1. Find the location where you want to mount the light. (Figure 1)
2. Mark the location where you want to mount the light by ensuring the mounting plate is level and then making two marks in the open holes on the mounting plate.
2. Measure the width of two holes on the back to align holes for 2 the screws (AA) on the surface. (The distance between the two holes is 85mm.)
3. Remove mounting plate and drill two 7.5mm holes.
- Note: If attaching to drywall or plaster surface proceed to step 4, if attaching to wood proceed to step 5.
4. Insert wall anchors into previously drilled holes, place mounting plate over hole locations and attach screws with screwdriver or drill.
- Note: Be careful not to over-tighten
5. Place mounting plate over previously drilled holes and attach screws with screwdriver or drill.

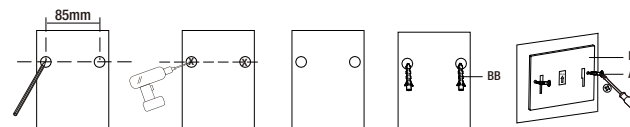

Figure 1

Mounting the Light

1. Mount the light on the mounting plate (DD) by aligning the slots on the back of the light to the slots on the front of the mounting plate. (Figure 2)
2. Slide and lock into place.

Each light requires 3 AA batteries (included)

1. To install the batteries (CC) remove 4 small screws on back of the light with a small screwdriver. (Figure 3)
2. Open back compartment and install 3 AA batteries (included) ensuring the polarity +/- is correct.
3. Place back compartment panel back over screw hole locations and replace screws to finish installation.

NOTE: Follow these steps for recurring battery installation

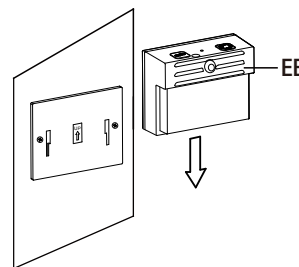

Figure 2

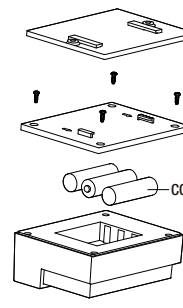

Figure 3

CAUTIONS

CAUTION STATEMENT

- Always purchase the correct size and grade of battery most suitable for the intended use.
- Always replace the whole set of batteries at one time, taking care not to mix old and new ones, or batteries of different types or brands.
- Clean the battery contacts and also those of the device prior to battery installation.
- Ensure the batteries are installed correctly with regard to polarity (+ and -).
- Remove batteries from equipment which is not to be used for an extended period of time.
- Remove used batteries promptly.
- For recycling and disposal of batteries to protect the environment, please check the internet or your local phone directory for local recycling centers and/or follow local government regulations.

OPERATING INSTRUCTIONS

NOTE: Each light has two buttons: 1) Power / Timer Button and 2) Link Button (Figure 4)

NOTE: The lights can be operated independently or linked together (maximum of 3 lights). Lights set up independently will sense motion 1 by 1 and not trigger other lights. Lights set up linked will sense motion on 1 light and turn on any other linked lights.

1. To operate lights independently, press power / timer button 1 time and the light will turn green and light will operate for 15 seconds. Press twice and light will operate 30 seconds. Press three times and light will operate 45 seconds.
2. To operate lights with linking, press the link button on each of the lights you want to link. You will see a red light which will indicate all lights have been linked successfully.

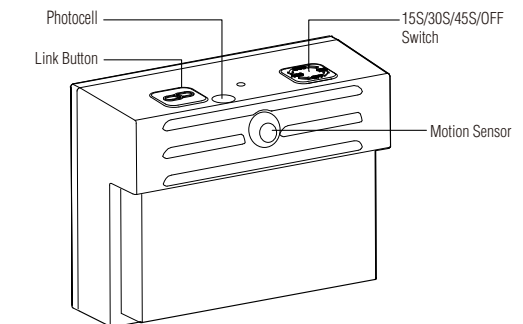

Figure 4

SAFETY INFORMATION

WARNING

1. This product is not a toy and contains small parts. Close supervision is necessary when this unit is used near children.
2. To reduce the risk of electrical shock, do not put the unit in water or other liquid. For cleaning, use a soft dry cloth. Do not place or store appliance where it can fall or be pulled into a tub or sink.

NOTE:

This equipment has been tested and found to comply with the limits for a Class B Digital Device, pursuant to Part 15 of the FCC Rules. These limits are designed to provide reasonable protection against harmful interference in a residential installation. This equipment generates, uses, and can radiate radio frequency energy and, if not installed and used in accordance with the instructions, may cause harmful interference to radio communications. However, there is no guarantee that interference will not occur in a particular installation. If this equipment does cause harmful interference to radio or television reception, which can be determined by turning the equipment off and on, the user is encouraged to try to correct the interference by one or more of the following measures:

- Reorient or relocate the receiving antenna.
- Increase the distance between the equipment and receiver.
- Connect the equipment to an outlet on a circuit different from that which the receiver is connected.
- Consult the dealer or an experienced radio/TV technician for help.

This equipment complies with Part 15 of the FCC Rules. Operation is subject to the following two conditions:

- 1) This device may not cause harmful interference.
- 2) This device must accept any interference received, including interference that may cause undesired operation.

WARNING: Changes or modifications to this unit not expressly approved by the party responsible for compliance could void the user's authority to operate the equipment.