



FCC 47 CFR PART 15 SUBPART C 15.247

TEST REPORT

FOR

TGBAND

Model :TGB003

Issued to

INTELINOVA SOFTWARE, S.L.
CAMINO DE LA GOLETA SN EDIF LA CELULOSA 1 LOCAL IZQ 04007
ALMERIA Spain
Issued by
WH Technology Corp.



Open Site	No.120, Ln. 5, Hudong St., Xizhi Dist., New Taipei City 221, Taiwan (R.O.C.)	
EMC Test Site	Xizhi Office and Lab	7F., No.262, Sec. 3, Datong Rd., Xizhi Dist., New Taipei City 221, Taiwan (R.O.C.)
Tel.: +886-7729-7707 Fax: +886-2- 8648-1311		

Note: This test refers exclusively to the test presented test model and sample. This report shall not be reproduced except in full, without the written approval of WH Technology Corp.. This document may be altered or revised by WH Technology Corp.. Personnel only, and shall be noted in the revision section of the document.



1. GENERAL INFORMATION.....	4
2. REPORT OF MEASUREMENTS AND EXAMINATIONS.....	5
2.1 LIST OF MEASUREMENTS AND EXAMINATIONS.....	5
3. TEST CONFIGURATION OF EQUIPMENT UNDER TEST.....	6
3.1 DESCRIPTION OF THE TESTED SAMPLES.....	6
3.2 CARRIER FREQUENCY OF CHANNELS.....	6
3.3 TEST MODE AND TEST SOFTWARE.....	7
3.4 TEST METHODOLOGY & GENERAL TEST PROCEDURES.....	8
4. TEST AND MEASUREMENT EQUIPMENT.....	10
4.1 CALIBRATION.....	10
4.2 EQUIPMENT.....	10
5. ANTENNA REQUIREMENTS.....	12
5.1 STANDARD APPLICABLE.....	12
5.2 ANTENNA CONSTRUCTION AND DIRECTIONAL GAIN.....	12
6. TEST OF CONDUCTED EMISSION.....	13
6.1 TEST LIMIT.....	13
6.2 TEST PROCEDURES.....	13
6.3 TYPICAL TEST SETUP.....	14
6.4 TEST RESULT AND DATA.....	15
7. TEST OF RADIATED EMISSION.....	17
7.1 TEST LIMIT.....	17
7.2 TEST PROCEDURES.....	17
7.3 TYPICAL TEST SETUP.....	18
7.4 TEST RESULT AND DATA (9KHZ ~ 30MHZ).....	19
7.5 TEST RESULT AND DATA (30MHZ ~ 1GHZ, WORST EMISSIONS FOUND).....	20
7.6 TEST RESULT AND DATA (ABOVE 1GHZ).....	22
7.7 RESTRICT BAND EMISSION MEASUREMENT DATA.....	23
8. 6DB BANDWIDTH MEASUREMENT DATA.....	28
8.1 TEST LIMIT.....	28
8.2 TEST PROCEDURES.....	28
8.3 TEST SETUP LAYOUT.....	28
8.4 TEST RESULT AND DATA.....	28
9. MAXIMUM PEAK AND AVERAGE OUTPUT POWER.....	32
9.1 TEST LIMIT.....	32
9.2 TEST PROCEDURES.....	32
9.3 TEST SETUP LAYOUT.....	32
9.4 TEST RESULT AND DATA.....	32
10. POWER SPECTRAL DENSITY.....	34
10.1 TEST LIMIT.....	34
10.2 TEST PROCEDURES.....	34
10.3 TEST SETUP LAYOUT.....	34
10.4 TEST RESULT AND DATA.....	34



11. BAND EDGES MEASUREMENT.....	38
11.1 TEST LIMIT.....	38
11.2 TEST PROCEDURE.....	38
11.3 TEST SETUP LAYOUT.....	38
11.4 TEST RESULT AND DATA.....	38
12. RESTRICTED BANDS OF OPERATION.....	41
12.1 LABELING REQUIREMENT.....	41



1. GENERAL INFORMATION

Applicant : INTELINOVA SOFTWARE, S.L.
Address : CAMINO DE LA GOLETA SN EDIF LA CELULOSA 1 LOCAL IZQ
04007 ALMERIA Spain
Manufacturer : Trainingym
Address : Camino de la Goleta, 1, 04007 Almeria, España, Spain
Factory : Vexos Dongguan Industrial Company Limited
Address : Plainvim Industrial Park, Zhongxin Avenue, Dongkeng Town,
Dongguan, Guangdong Province, P.R.China
EUT : TGBand
Model Name : TGB003
Trade Name : TGBand
Model : N/A
Differences

Is here with confirmed to comply with the requirements set out in the FCC Rules and Regulations Part 15 Subpart C and the measurement procedures were according to ANSI C63.10-2013. The said equipment in the configuration described in this report shows the maximum emission levels emanating

FCC part 15 Subpart C

Receipt Date : 07/02/2018

Final Test Date :07/28/2018

Tested By:

Reviewed by:

July 28, 2018
(Date)

Bing Chang/ Engineer

July 28, 2018
(Date)





Bell Wei / Manager
Designation Number: TW2954



2. REPORT OF MEASUREMENTS AND EXAMINATIONS

2.1 LIST OF MEASUREMENTS AND EXAMINATIONS

FCCRule	Description of Test	Result
15.203	. Antenna Requirement	Pass
15.207	. Conducted Emission	Pass
15.205 15.209 15.247(d)	. Radiated Emission	Pass
15.247(a)(2)	. 6dB Bandwidth	Pass
15.247(b)(3)	. Maximum Peak Output Power	Pass
15.247(d)	. 100kHz Bandwidth of Frequency Band Edges	Pass
15.247(e)	. Power Spectral Density	Pass
1.1307 1.1310 2.1091 2.1093	. RF Exposure Compliance	Pass



3. TEST CONFIGURATION OF EQUIPMENT UNDER TEST

3.1 DESCRIPTION OF THE TESTED SAMPLES

EUT Name	:	TGBand
Model Number	:	TGB003
FCC ID	:	2AP27-TGB
Internal Battery	:	3.7V , 30mAh,0.22Wh
Nominal voltage	:	DC 5V from adapter
USB Line	:	Unshielded, Detachable 0.2m
Operate Frequency	:	2402~2480MHz
Modulation Technique	:	GFSK
Number of Channels	:	40 CH
Bluetooth Version	:	BT 5.0 BLE
Antenna Type	:	Fractus Antenna
Channel Space	:	2MHz
Antenna gain	:	0.2dBi

3.2 CARRIER FREQUENCY OF CHANNELS

Channel No.	Frequency (MHz)	Channel No.	Frequency (MHz)
1	2402	21	2442
2	2404	22	2444
3	2406	23	2446
4	2408	24	2448
5	2410	25	2450
6	2412	26	2452
7	2414	27	2454
8	2416	28	2456
9	2418	29	2458
10	2420	30	2460
11	2422	31	2462
12	2424	32	2464
13	2426	33	2466
14	2428	34	2468
15	2430	35	2470
16	2432	36	2472
17	2434	37	2474
18	2436	38	2476
19	2438	39	2478
20	2440	40	2480



3.3 TEST MODE AND TEST SOFTWARE

Channel		Frequency MHz
1		2402
20		2440
40		2480
Test Item	Software	Description
Conducted RF Testing and Radiated testing	nRF Toolbox	Touch EUT switching frequency after sending a fixed frequency command through the App



3.4 TEST METHODOLOGY & GENERAL TEST PROCEDURES

All testing as described bellowed were performed in accordance with ANSI C63.10:2013 and FCC CFR 47 Part 15 Subpart C.

Conducted Emissions

The EUT is placed on a wood table, which is at 0.8 m above ground plane acceding to clause 15.207 and requirements of ANSI C63.10:2013. Conducted emissions from the EUT measured in the frequency range between 0.15 MHz and 30MHz are using CISPR Quasi-Peak / Average detectors.

Radiated Emissions

The EUT is a placed on a turn table, which is 0.8 m above ground plane. The turntable was rotated through 360 degrees to determine the position of maximum emission level. The EUT is placed at 3m away from the receiving antenna, which varied from 1m to 4m to find out the highest emission. Each emission was to be maximized by changing the polarization of receiving antenna both horizontal and vertical.

- 1)Putting the EUT on the platform and turning on the EUT (on/off button on the bottom of the EUT).
- 2)Setting test channel described as “Channel setting and operating condition” , and testing channel by channel.
- 3)For the maximum output power measurement, we followed the method of measurement KDB558074 D01.
- 4)For the spurious emission test based on ANSI(2014), at the frequency where below 1GHz used quasi-peak detector mode; where above 1GHz used the peak and average detector mode. IF the peak value may be under average limit, the average mode will not be performed.

3.5 MEASUREMENT UNCERTAINTY

Measurement Item	Uncertainty
Radiated emission	±4.11dB
Peak Output Power(conducted)	±1.38dB
Peak Output Power(Radiated)	±1.70dB
Power Spectral Density	±1.39dB
Radiated emission(3m)	±4.11dB
Radiated emission(10m)	±3.89dB



3.6 DESCRIPTION OF THE SUPPORT EQUIPMENTS

Setup Diagram

See test photographs attached in appendix 1 for the actual connections between EUT and support equipment.

Support Equipment

Peripherals Devices:

OUTSIDE SUPPORT EQUIPMENT							
No.	Equipment	Model	Serial No.	FCC ID	Trade name	Date Cable	Power Cord
1.	AC adapter	QX6.5W7 5100FG	N/A	VOC	Stos	N/A	N/A
2.	N/A	N/A	N/A	N/A	N/A	N/A	N/A
INSIDE SUPPORT EQUIPMENT							
No.	Equipment	Model	Serial No.	FCC ID	Trade name	Date Cable	Power Cord
1.	N/A	N/A	N/A	N/A	N/A	N/A	N/A

Note: All the above equipment /cable were placed in worse case position to maximize emission signals during emission test

Grounding: Grounding was in accordance with the manufacturer' s requirement and conditions for the intended use.



4. TEST AND MEASUREMENT EQUIPMENT

4.1 CALIBRATION

The measuring equipment utilized to perform the tests documented in the report has been calibrated once a year or in accordance with the manufacturer's recommendations, and is traceable to recognized national standards.

4.2 EQUIPMENT

The following list contains measurement equipment used for testing. The equipment conforms to the requirement of CISPR 16-1, ANSI C63.2 and other required standards. Calibration of all test and measurement, including any accessories that may affect such calibration, is checked frequently to ensure the accuracy. Adjustments are made and correction factors are applied in accordance with the instructions contained in the respective.



TABLELIST OF TEST AND MEASUREMENT EQUIPMENT

Instrument	Manufacturer	Model No.	S/N	Next Cal. Date
EMI Receiver	R&S	ESHS10	830223/008	2019/06/06
LISN	Rolf Heine Hochfrequenztechnik	NNB-2/16z	98062	2019/06/11
ISN	Schwarzbeck	8-Wire ISN CAT5	CAT5-8158- 0094	2018/09/21
RF Cable	N/A	N/A	EMI-3	2018/10/19
Bilog antenna(30M-1G)	ETC	MCTD2786 B	BLB16M040 04/JB-5-004	2019/05/18
Double Ridged Guide Horn antenna(1G-18G)	ETC	MCTD 1209	DRH15N020 09	2018/11/23
Horn antenna (18G-26G)	com-power	AH-826	81000	2019/08/16
LOOP Antenna (Below 30M)	com-power	AL-130	17117	2018/10/04
Pre amplifier (30M-1G)	EMC INSTRUMENT	EMC9135	980334	2019/05/03
Microwave Preamplifier (1G-18G)	EMC INSTRUMENT	EMC05184 5	980108&AT -18001	2018/10/23
Pre amplifier (18G~26G)	MITEQ	JS4-180026 00-30-5A	808329	2019/08/09
EMI Test Receiver	R&S	ESVS30 (20M-1000 MHz)	826006/002	2018/11/28
RF Cable (open site)	EMCI	N male on end of both sides (EMI4)	30m	2018/10/19
RF CABLE (1~26G)	HARBOUT INDUSTRIES	LL142MI(4 M+4M)	NA	2019/04/17
RF CABLE (1~26G)	HARBOUT INDUSTRIES	LL142MI(7 M)	NA	2019/08/09
Spectrum (9K--7GHz)	R&S	FSP7	830180/006	2019/04/14
Spectrum (9K--40GHz)	AGILENT	8564EC	4046A0032	2019/03/01
e3	AUDIX	N/A	N/A	N/A
SINGAL GENERATOR (100k-1GHz)	HP	8648A	3619U0042 6	N/A
Power Meter	ANRITSU	ML2487	6K00001574	2019/08/09

***CALIBRATION INTERVAL OF INSTRUMENTS LISTED ABOVE IS ONE YEAR**



5. ANTENNA REQUIREMENTS

5.1 STANDARD APPLICABLE

For intentional device, according to FCC 47 CFR Section 15.203, an intentional radiator shall be designed to ensure that no antenna other than that furnished by the responsible party shall be used with the device. And according to FCC 47 CFR Section 15.247 (b), if transmitting antennas of directional gain greater than 6dBi are used, the power shall be reduced by the amount in dB that the directional gain of the antenna exceeds 6dBi.

5.2 ANTENNA CONSTRUCTION AND DIRECTIONAL GAIN

BLE	
Antenna Type	: Fractus Antenna
Antenna Gain	: 0.2 dBi



6. TEST OF CONDUCTED EMISSION

6.1 TEST LIMIT

Conducted Emissions were measured from 150 kHz to 30 MHz with a bandwidth of 9 KHz on the 120 VAC power and return leads of the EUT according to the methods defined in ANSI C63.10-2013 Section 3.1. The EUT was placed on a nonmetallic stand in a shielded room 0.8 meters above the ground plane as shown in section 2.2. The interface cables and equipment positioning were varied within limits of reasonable applications to determine the position produced maximum conducted emissions.

Frequency (MHz)	Quasi Peak (dB μ V)	Average (dB μ V)
0.15 – 0.5	66-56*	56-46*
0.5 – 5.0	56	46
5.0 – 30.0	60	50

*Decreases with the logarithm of the frequency.

6.2 TEST PROCEDURES

- a. The EUT was placed 0.4 meter from the conducting wall of the shielding room was kept at least 80 centimeters from any other grounded conducting surface.
- b. Connect EUT to the power mains through a line impedance stabilization network (LISN).
- c. All the support units are connecting to the other LISN.
- d. The LISN provides 50 ohm coupling impedance for the measuring instrument.
- e. The FCC states that a 50 ohm, 50 micro-Henry LISN should be used.
- f. Both sides of AC line were checked for maximum conducted interference.
- g. The frequency range from 150 kHz to 30 MHz was searched.
- h. Set the test-receiver system to Peak Detect Function and Specified Bandwidth with Maximum Hold Mode.



6.3 TYPICAL TEST SETUP

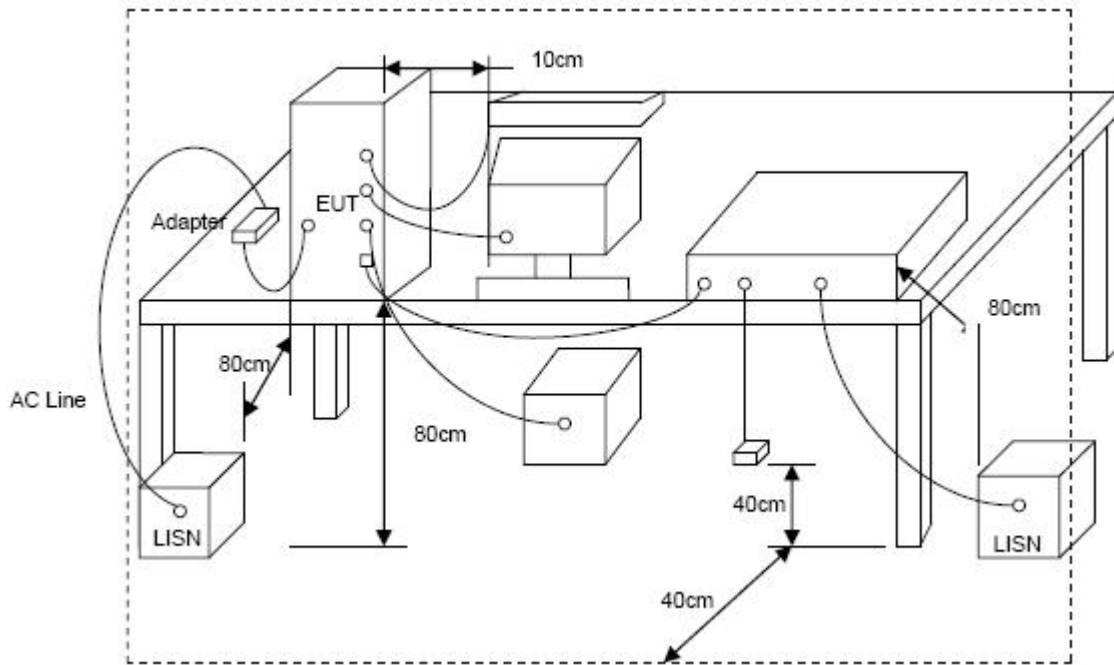



6.4 TEST RESULT AND DATA

M/N :	TGB003	Test Voltage:	AC 120V/60Hz
Test Date :	July 11, 2018	Phase:	L1
Temperature:	20°C	Relative Humidity:	54%
Pressure:	101.0KPa	Test by:	Bing
Test Mode:	Charging		

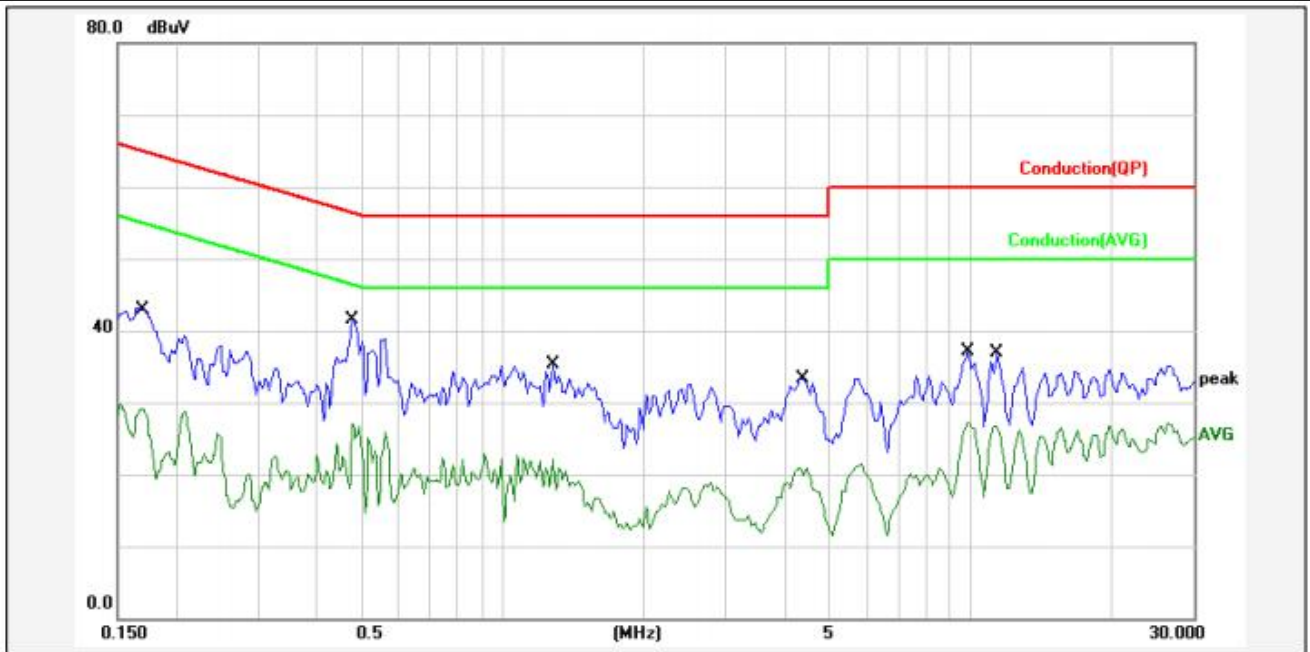

No.	Frequency (MHz)	Factor (dB)	Reading (dBuV)	Level (dBuV)	Limit (dBuV)	Margin (dB)	Detector	P/F	Remark
1	0.1703	9.62	29.98	39.60	64.95	-25.35	QP	P	
2	0.1703	9.62	19.55	29.17	54.95	-25.78	AVG	P	
3	0.4778	9.62	28.98	38.60	56.38	-17.78	QP	P	
4	0.4778	9.62	17.56	27.18	46.38	-19.20	AVG	P	
5	1.2786	9.66	22.94	32.60	56.00	-23.40	QP	P	
6	1.2786	9.66	12.39	22.05	46.00	-23.95	AVG	P	
7	4.3910	9.72	21.58	31.30	56.00	-24.70	QP	P	
8	4.3910	9.72	11.13	20.85	46.00	-25.15	AVG	P	
9	9.8661	9.81	25.79	35.60	60.00	-24.40	QP	P	
10	9.8661	9.81	17.50	27.31	50.00	-22.69	AVG	P	
11	11.3813	9.86	24.04	33.90	60.00	-26.10	QP	P	
12	11.3813	9.86	16.85	26.71	50.00	-23.29	AVG	P	



M/N :	TGB003	Test Voltage:	AC 120V/60Hz
Test Date :	July 11, 2018	Phase:	Neutral
Temperature:	20°C	Relative Humidity:	54%
Pressure:	101.0KPa	Test by:	Bing
Test Mode:	Charging		

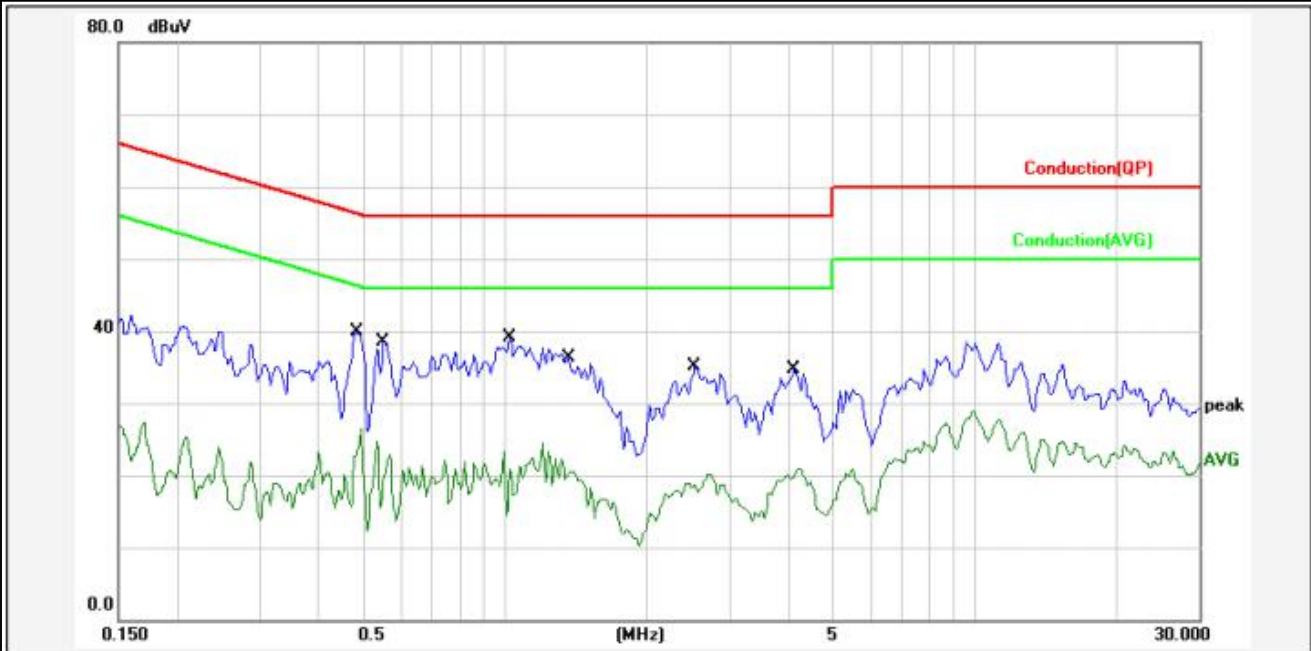

No.	Frequency (MHz)	Factor (dB)	Reading (dBuV)	Level (dBuV)	Limit (dBuV)	Margin (dB)	Detector	P/F	Remark
1	0.4854	9.61	27.89	37.50	56.25	-18.75	QP	P	
2	0.4854	9.61	16.84	26.45	46.25	-19.80	AVG	P	
3	0.5512	9.61	25.99	35.60	56.00	-20.40	QP	P	
4	0.5512	9.61	15.04	24.65	46.00	-21.35	AVG	P	
5	1.0238	9.63	27.27	36.90	56.00	-19.10	QP	P	
6	1.0238	9.63	13.74	23.37	46.00	-22.63	AVG	P	
7	1.3624	9.64	23.86	33.50	56.00	-22.50	QP	P	
8	1.3624	9.64	10.83	20.47	46.00	-25.53	AVG	P	
9	2.5301	9.68	22.92	32.60	56.00	-23.40	QP	P	
10	2.5301	9.68	9.27	18.95	46.00	-27.05	AVG	P	
11	4.1210	9.72	21.78	31.50	56.00	-24.50	QP	P	
12	4.1210	9.72	11.19	20.91	46.00	-25.09	AVG	P	



7. TEST OF RADIATED EMISSION

7.1 TEST LIMIT

In any 100kHz bandwidth outside the frequency band in which the spread spectrum or digitally modulated intentional radiator is operating, the radio frequency power that is produced by the intentional radiator shall be at least 20dB below that in the 100kHz bandwidth within the band that contains the highest level of the desired power, based on either an RF conducted or a radiated measurement. If the transmitter measurement is based on the maximum conducted output power, the attenuation required under this paragraph shall be 30dB instead of 20dB. In addition, radiated emissions which fall in section 15.205(a) the restricted bands must also comply with the radiated emission limit specified in section 15.209(a).

Frequency (MHz)	Field Strength (microvolt/meter)	Measurement Distance (meters)
0.009 ~ 0.490	2400/F(kHz)	300
0.490 ~ 1.705	24000/F(kHz)	30
1.705 ~ 30.0	30	30
30 ~ 88	100	3
88 ~ 216	150	3
216 ~ 960	200	3
Above 960	500	3

7.2 TEST PROCEDURES

- a. The EUT was placed on a rotatable table top 0.8 meter above ground.
- b. The EUT was set 3 meters from the interference receiving antenna which was mounted on the top of a variable height antenna tower.
- c. The table was rotated 360 degrees to determine the position of the highest radiation.
- d. The antenna is a broadband antenna and its height is varied between one meter and four meters above ground to find the maximum value of the field strength both horizontal polarization and vertical polarization of the antenna are set to make the measurement.
- e. For each suspected emission the EUT was arranged to its worst case and then tune the antenna tower (from 1 M to 4 M) and turn table (from 0 degree to 360 degrees) to find the maximum reading.
- f. Set the test-receiver system to Peak or CISPR quasi-peak Detect Function and specified bandwidth with Maximum Hold Mode.
- g. If the emission level of the EUT in peak mode was 3 dB lower than the limit specified, then testing will be stopped and peak values of EUT will be reported,



- otherwise, the emissions which do not have 3 dB margin will be repeated one by one using the quasi-peak method and reported.
- h. For testing above 1GHz, the emission level of the EUT in peak mode was 20dB lower than average limit (that means the emission level in peak mode also complies with the limit in average mode), then testing will be stopped and peak values of EUT will be reported, otherwise, the emissions will be measured in average mode again and reported.
 - i. “ Cone of radiation ” has been considered to be 3dB bandwidth of the measurement antenna.

7.3 TYPICAL TEST SETUP

Radiated Emission Test Set-Up, Frequency Below 30MHz

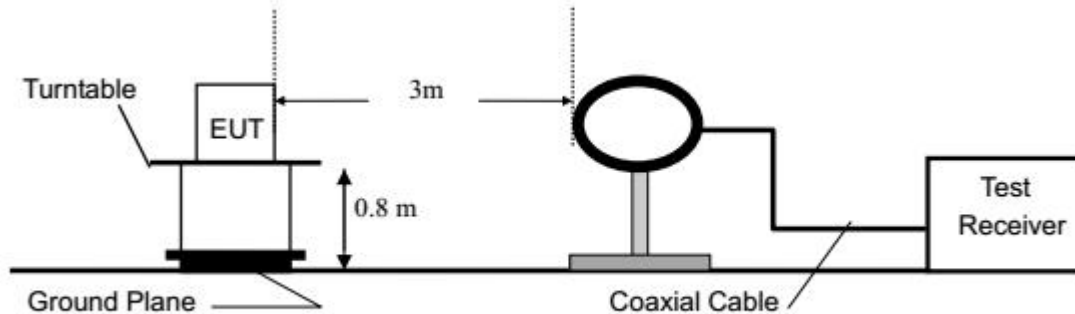

Radiated Emission Test Set-Up, Frequency 30MHz-1000MHz

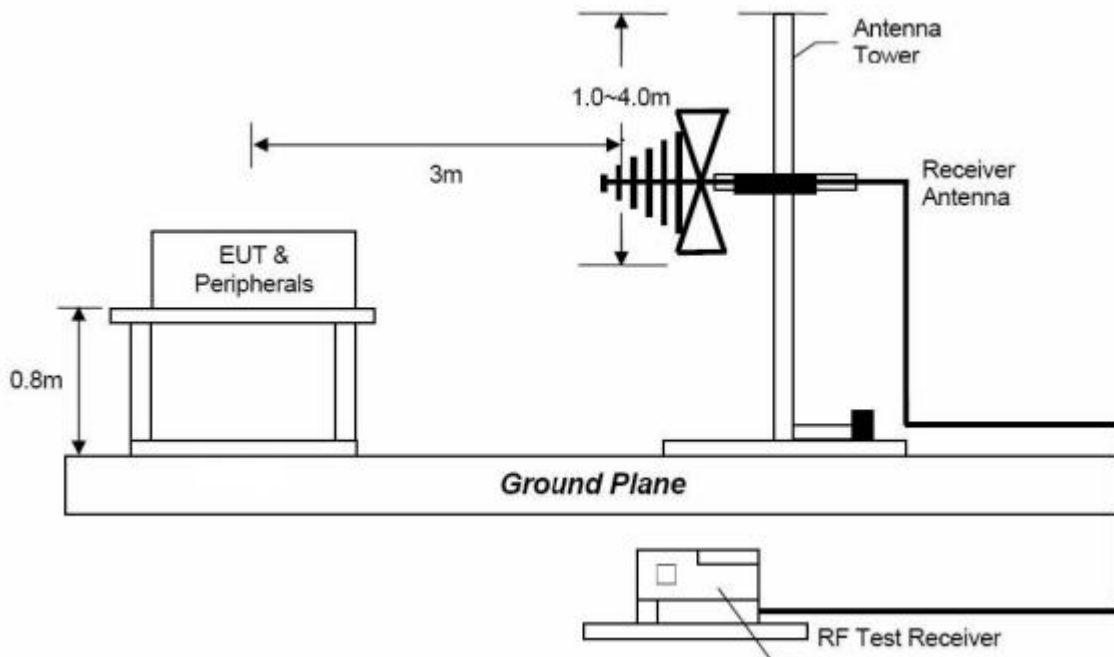



Radiated Emission Test Set-Up, Frequency above 1GHz

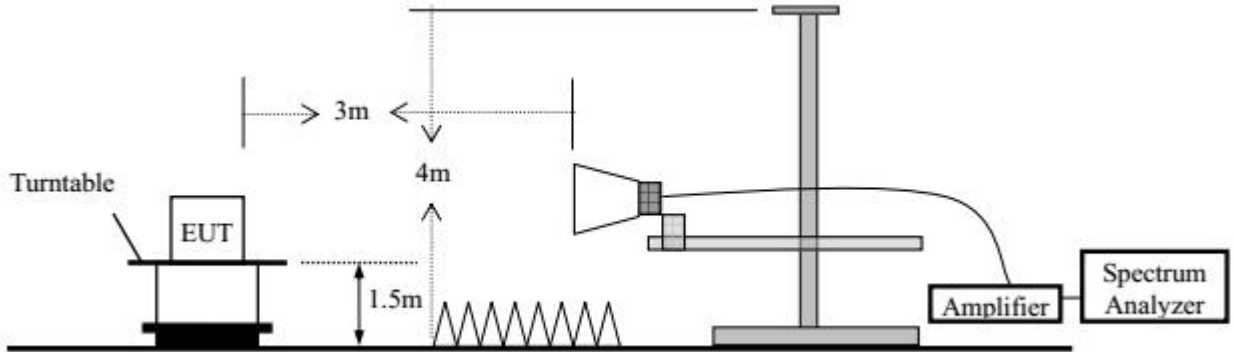

7.4 TEST RESULT AND DATA (9KHZ ~ 30MHZ)

The 9kHz - 30MHz spurious emission is under limit 20dB more.



7.5 TEST RESULT AND DATA (30MHZ ~ 1GHZ, WORST EMISSIONS FOUND)

M/N :	TGB003	Test Voltage:	AC 120V/60Hz
Test Date :	July 14, 2018	Phase:	Vertical
Temperature:	20°C	Relative Humidity:	54%
Pressure:	101.0KPa	Test by:	Bing
Test Mode:	Low channel		

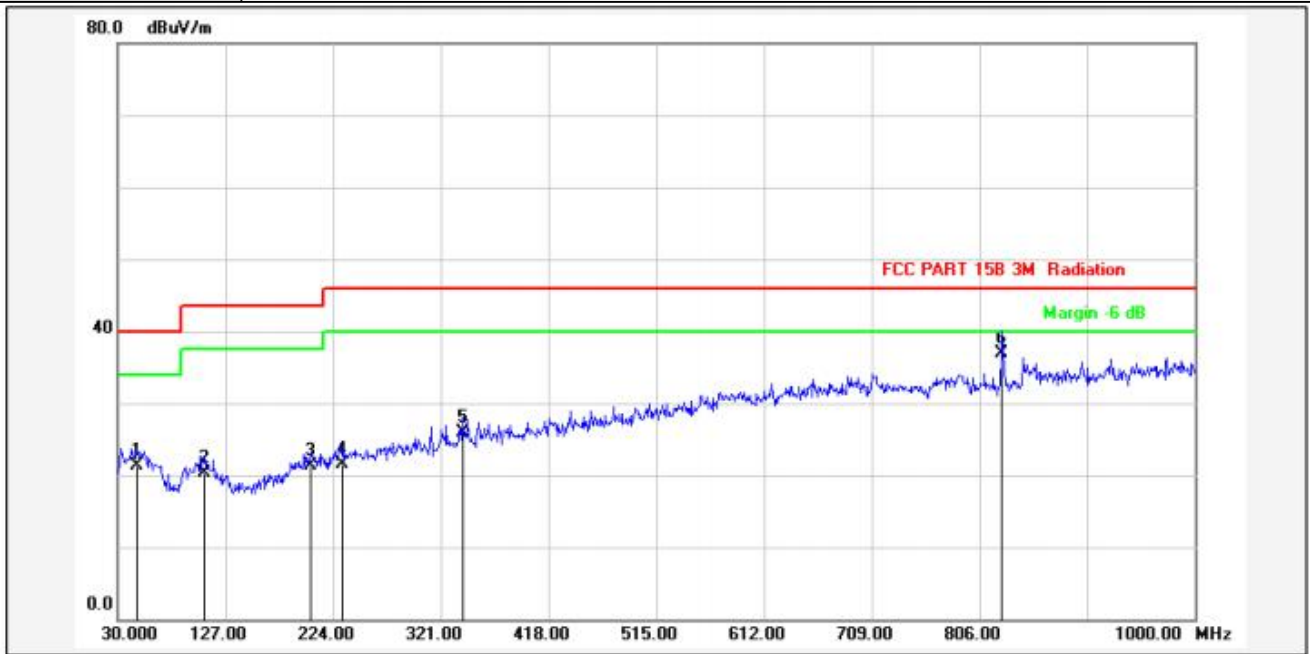

No.	Frequency (MHz)	Factor (dB/m)	Reading (dBuV)	Level (dBuV/m)	Limit (dBuV/m)	Margin (dB)	Detector	Height (cm)	Azimuth (deg.)	P/F	Remark
1	47.4600	16.14	5.16	21.30	40.00	-18.70	QP			P	
2	108.5700	14.15	6.15	20.30	43.50	-23.20	QP			P	
3	203.6300	13.88	7.42	21.30	43.50	-22.20	QP			P	
4	232.7300	14.47	7.13	21.60	46.00	-24.40	QP			P	
5	340.4000	17.44	8.52	25.96	46.00	-20.04	QP			P	
6	826.3700	25.02	11.88	36.90	46.00	-9.10	QP			P	



M/N :	TGB003	Test Voltage:	AC 120V/60Hz
Test Date :	July 14, 2018	Phase:	Horizontal
Temperature:	20°C	Relative Humidity:	54%
Pressure:	101.0KPa	Test by:	Bing
Test Mode:	Low channel		

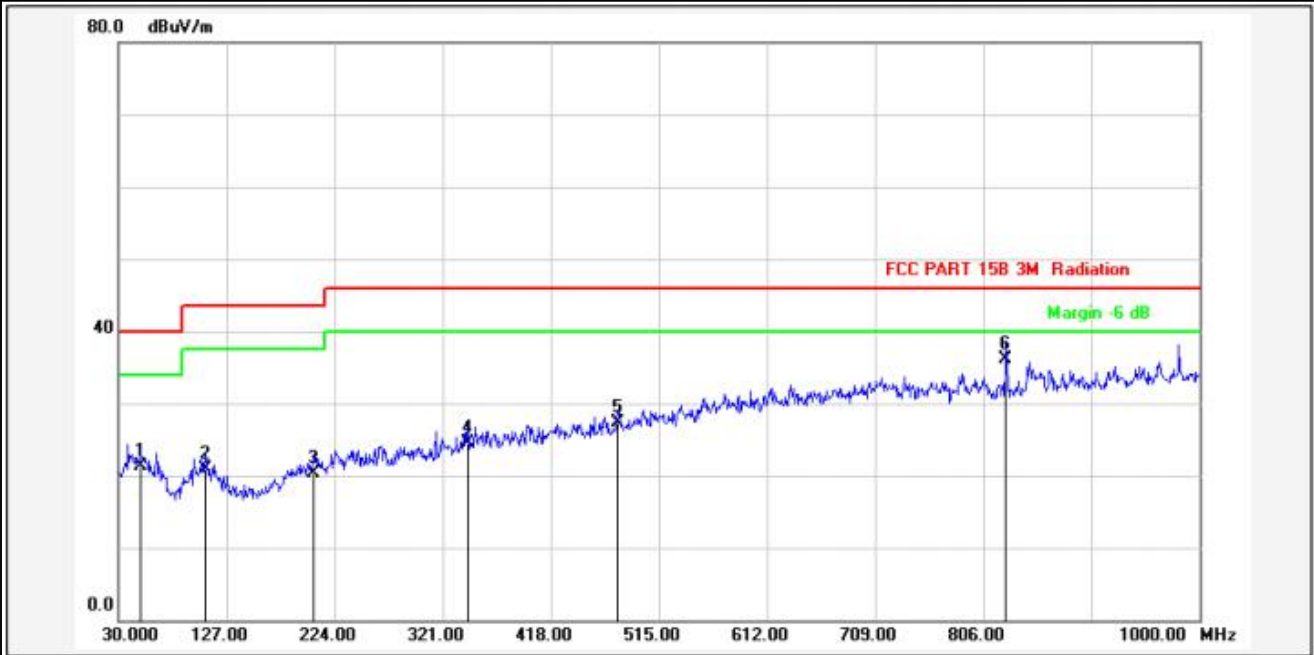

No.	Frequency (MHz)	Factor (dB/m)	Reading (dBuV)	Level (dBuV/m)	Limit (dBuV/m)	Margin (dB)	Detector	Height (cm)	Azimuth (deg.)	P/F	Remark
1	49.4000	16.12	5.18	21.30	40.00	-18.70	QP			P	
2	107.6000	19.15	1.85	21.00	43.50	-22.50	QP			P	
3	205.5700	16.76	3.54	20.30	43.50	-23.20	QP			P	
4	343.3100	17.54	6.96	24.50	46.00	-21.50	QP			P	
5	478.1400	19.81	7.49	27.30	46.00	-18.70	QP			P	
6	826.3700	25.02	11.18	36.20	46.00	-9.80	QP			P	



7.6 TEST RESULT AND DATA (ABOVE 1GHZ)

M/N :	TGB003	Test Voltage:	AC 120V/60Hz
Test Date :	July 14, 2018	Phase:	Vertical
Temperature:	20°C	Relative Humidity:	54%
Pressure:	101.0KPa	Test by:	Bing
Test Mode:	BLE		

Operation Mode: (Low channel)

Freq (MHz)	Ant.Pol (H/V)	Reading Level (dBuV)		Factor (dB)	Emission Level (dBuV/m)		Limit 3m (dBuV/m)		Margin (dB)	
		PK	AV		PK	AV	PK	AV	PK	AV
4824	V	45.33	33.25	14.05	59.38	47.30	74.00	54.00	-14.62	-6.70
7236	V	37.84	27.62	18.81	56.65	46.43	74.00	54.00	-17.35	-7.57

4824	H	46.25	31.98	14.05	60.30	46.03	74.00	54.00	-13.70	-7.97
7236	H	38.07	26.02	18.18	56.25	44.20	74.00	54.00	-17.75	-9.80

Operation Mode: (Mid channel)

Freq (MHz)	Ant.Pol (H/V)	Reading Level (dBuV)		Factor (dB)	Emission Level (dBuV/m)		Limit 3m (dBuV/m)		Margin (dB)	
		PK	AV		PK	AV	PK	AV	PK	AV
4874	V	46.40	31.55	14.41	60.81	45.96	74.00	54.00	-13.19	-8.04
7311	V	41.22	26.96	18.36	59.58	45.32	74.00	54.00	-14.42	-8.68

4874	H	45.26	32.06	14.41	59.67	46.47	74.00	54.00	-14.33	-7.53
7311	H	39.04	27.04	18.36	57.40	45.40	74.00	54.00	-16.60	-8.60

Operation Mode:(High channel)

Freq (MHz)	Ant.Pol (H/V)	Reading Level (dBuV)		Factor (dB)	Emission Level (dBuV/m)		Limit 3m (dBuV/m)		Margin (dB)	
		PK	AV		PK	AV	PK	AV	PK	AV
4924	V	45.59	32.32	14.76	60.35	47.08	74.00	54.00	-13.65	-6.92
7386	V	38.27	26.63	18.55	56.82	45.18	74.00	54.00	-17.18	-8.82

4924	H	45.68	31.99	14.76	60.44	46.75	74.00	54.00	-13.56	-7.25
7386	H	38.77	26.56	18.55	57.32	45.11	74.00	54.00	-16.68	-8.89



7.7 RESTRICT BAND EMISSION MEASUREMENT DATA

M/N :	TGB003			Test Voltage:	AC 120V/60Hz					
Test Date :	July 14, 2018			Phase:	Vertical					
Temperature:	20°C			Relative Humidity:	54%					
Pressure:	101.0KPa			Test by:	Bing					
Test Mode:	BLE									
Freq (MHz)	Ant.Pol (H/V)	Reading Level (dBuV)		Factor (dB)	Emission Level (dBuV/m)		Limit 3m (dBuV/m)		Margin (dB)	
		PK	AV		PK	AV	PK	AV	PK	AV
2390.000	H	33.97	18.24	12.56	46.53	30.80	74	54	-27.47	-23.20
2390.000	V	38.43	21.14	12.56	50.99	33.70	74	54	-23.01	-20.30
2483.500	H	30.03	17.53	12.67	45.70	30.20	74	54	-28.30	-23.80
2483.500	V	38.64	23.53	12.67	51.31	36.20	74	54	-22.69	-17.80



M/N :	TGB003	Test Voltage:	AC 120V/60Hz
Test Date :	July 14, 2018	Phase:	Vertical
Temperature:	20°C	Relative Humidity:	54%
Pressure:	101.0KPa	Test by:	Bing
Test Mode:	Low channel		

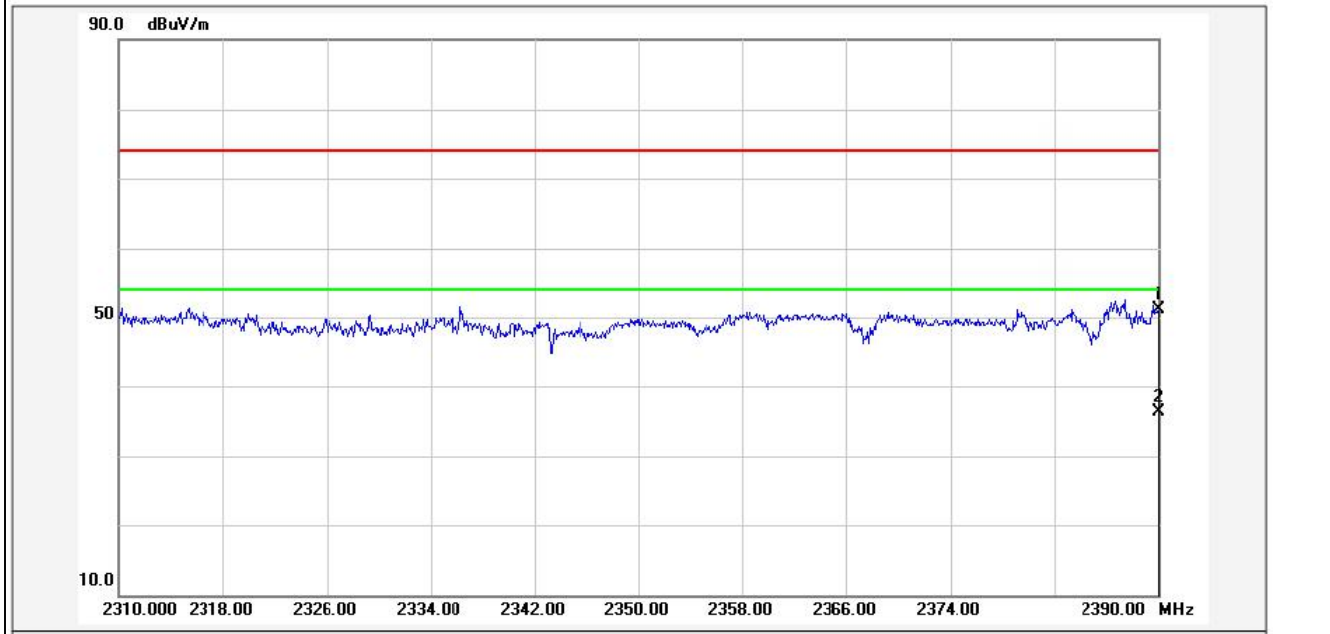



M/N :	TGB003	Test Voltage:	AC 120V/60Hz
Test Date :	July 14, 2018	Phase:	Horizontal
Temperature:	20°C	Relative Humidity:	54%
Pressure:	101.0KPa	Test by:	Bing
Test Mode:	Low channel		

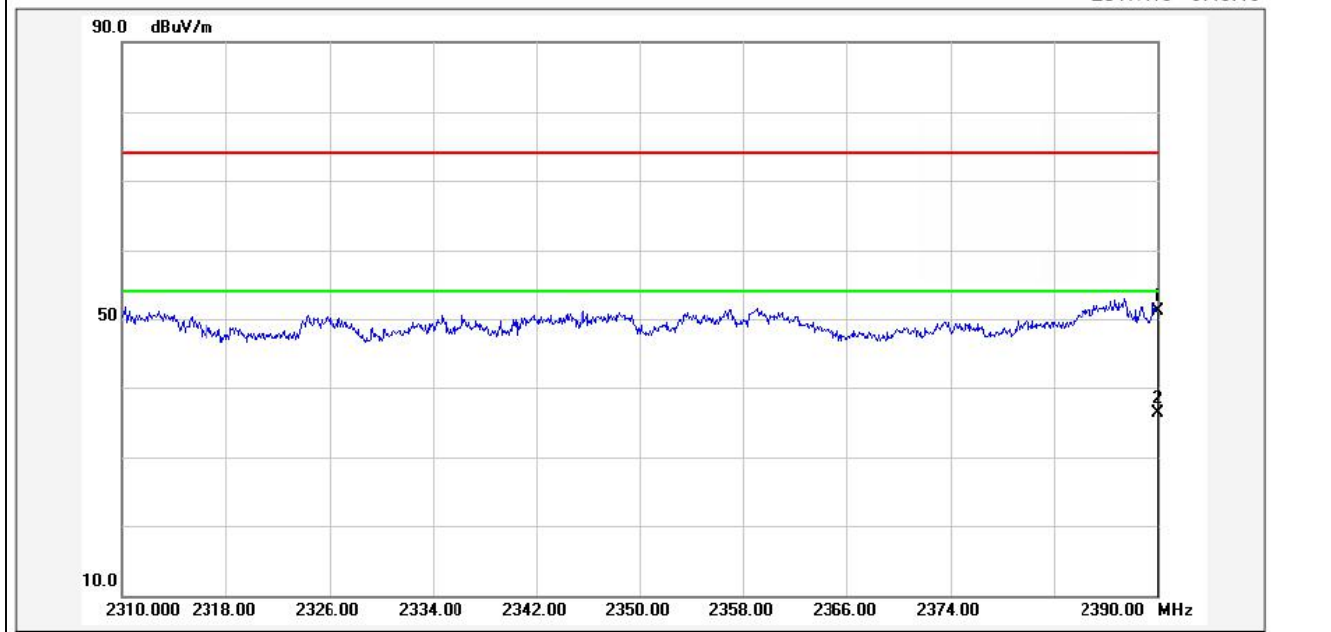



M/N :	TGB003	Test Voltage:	AC 120V/60Hz
Test Date :	July 14, 2018	Phase:	Vertical
Temperature:	20°C	Relative Humidity:	54%
Pressure:	101.0KPa	Test by:	Bing
Test Mode:	High channel		

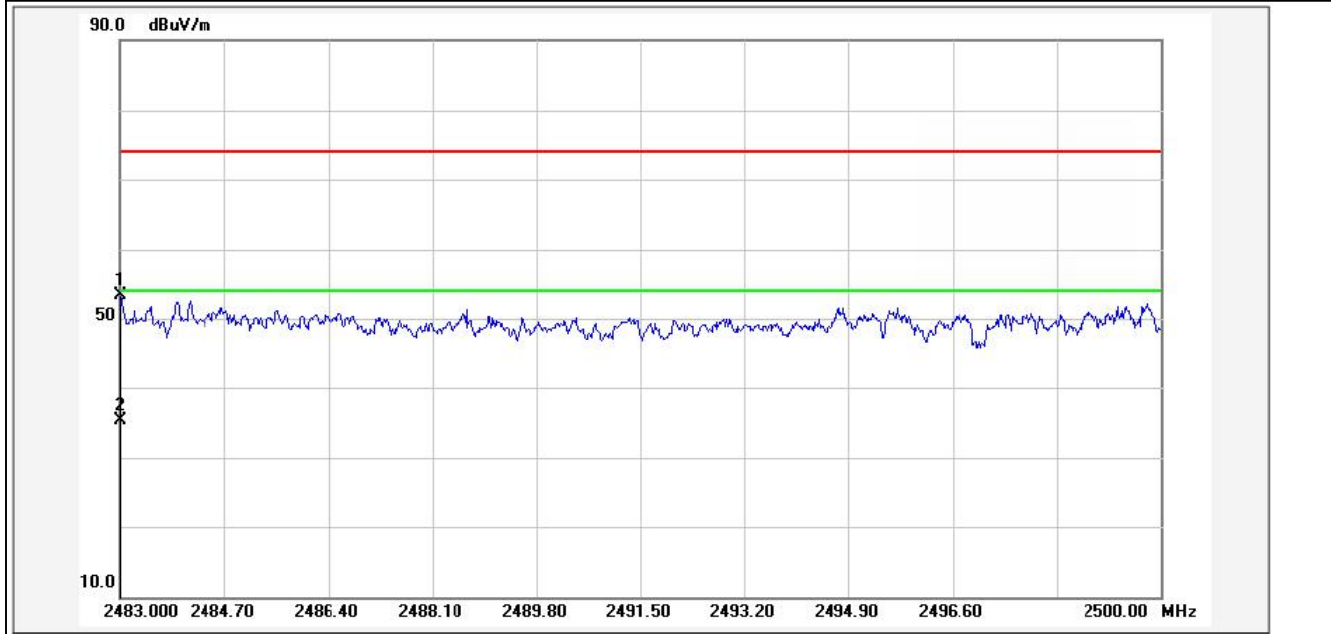



M/N :	TGB003	Test Voltage:	AC 120V/60Hz
Test Date :	July 14, 2018	Phase:	Horizontal
Temperature:	20°C	Relative Humidity:	54%
Pressure:	101.0KPa	Test by:	Bing
Test Mode:	High channel		

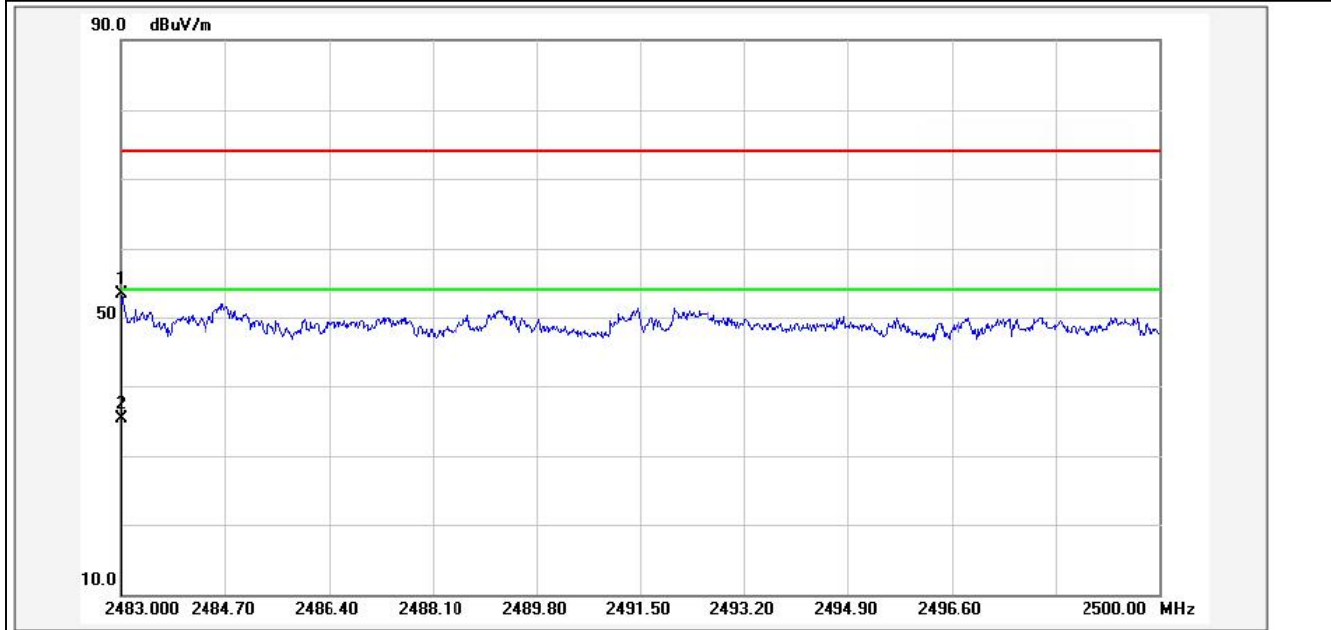

Note:

1. Emission level = Reading level + Correction factor
2. Correction factor : Antenna factor, Cable loss, Pre-Amp, etc.
3. All emissions as described above were determining by rotating the EUT through three orthogonal axes to maximizing the emissions if the EUT belongs to hand-held or body-worn devices.
4. Measurements above 1000 MHz, Peak detector setting:1 MHz RBW with 1 MHz VBW (Peak Detector).
5. Measurements above 1000 MHz, Average detector setting:1 MHz RBW with 10Hz VBW (RMS Detector).
6. Peak detector measurement data will represent the worst case results.
7. Where limits are specified for both average and peak detector functions, if the peak measured value complies with the average limit, it is unnecessary to perform an average measurement.



8. 6DB BANDWIDTH MEASUREMENT DATA

8.1 TEST LIMIT

The minimum of 6dB Bandwidth Measurement is 0.5 MHz.
Test Procedures

8.2 TEST PROCEDURES

- a. The transmitter output was connected to the spectrum analyzer.
- b. Set RBW of spectrum analyzer to 100KHz of the emission bandwidth and VBW $\geq 3x$ RBW.
- c. The 6 dB bandwidth is defined as the total spectrum the power of which is higher than peak power minus 6 dB.
- d. The 6dB Bandwidth was measured and recorded.

8.3 TEST SETUP LAYOUT

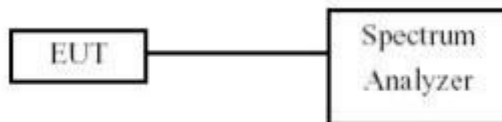

8.4 TEST RESULT AND DATA

PASS

Please refer to following table.



Temperature :	22 °C	Humidity:	56%	Pressure:	101.45KPa
Test By:	Bing		Test Date :	July 25, 2018	
Frequency MHz	Data Rate Mbps	6dB Bandwidth KHz		Limit	
GFSK					
Low Channel: 2402	1	692.8		>500KHz	
Middle Channel: 2440	1	688.5		>500KHz	
High Channel: 2480	1	688.4		>500KHz	



Low Channel

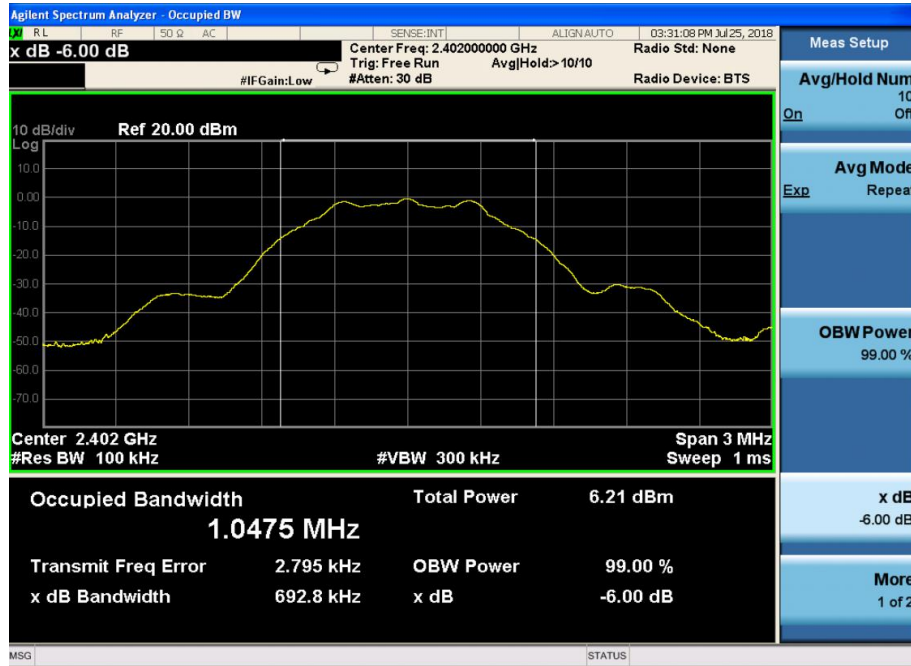

Middle Channel

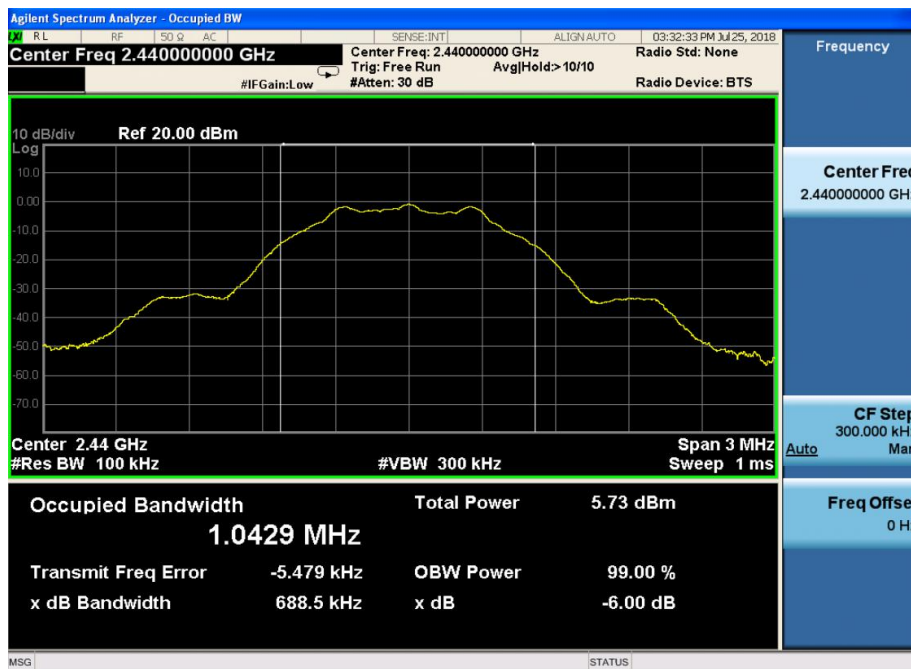



High Channel

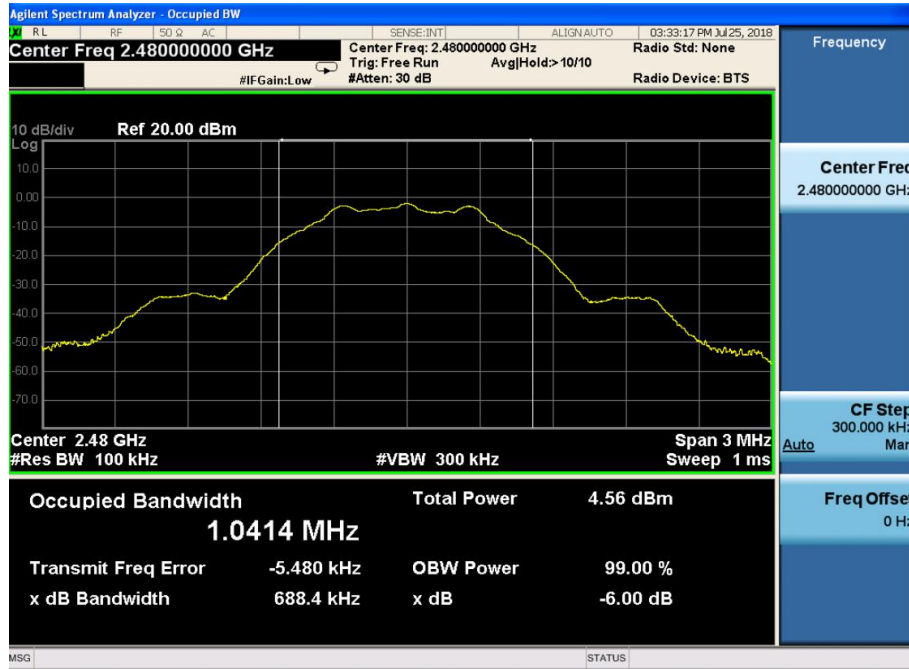



9. MAXIMUM PEAK AND AVERAGE OUTPUT POWER

9.1 TEST LIMIT

The Maximum Peak Output Power Measurement is 30dBm.

9.2 TEST PROCEDURES

The transmitter output (antenna port) was connected to the power meter. According to KDB558074 D01 DTS Measurement Guidance Section 9.1 Maximum peak conducted output power, 9.1.2 the maximum peak conducted output power may be measured using a broadband peak RF power meter. The power meter shall have a video bandwidth that is greater than or equal to the DTS bandwidth and shall utilize a fast-responding diode detector.

According to KDB558074 D01 DTS Measurement Guidance Section 9.2 Maximum average conducted output power, 9.2.3.1 Method AVGPM (Measurement using an RF average power meter)

(a) As an alternative to spectrum analyzer or EMI receiver measurements, measurements may be performed using a wideband RF power meter with a thermocouple detector or equivalent if all of the conditions listed below are satisfied.

- 1) The EUT is configured to transmit continuously, or to transmit with a constant duty factor.
 - 2) At all times when the EUT is transmitting, it shall be transmitting at its maximum power control level.
 - 3) The integration period of the power meter exceeds the repetition period of the transmitted signal by at least a factor of five.
- (b) If the transmitter does not transmit continuously, measure the duty cycle (x) of the transmitter output signal as described in Section 6.0.
- (c) Measure the average power of the transmitter. This measurement is an average over both the on and off periods of the transmitter.
- (d) Adjust the measurement in dBm by adding $10\log(1/x)$, where x is the duty cycle to the measurement result.

9.3 TEST SETUP LAYOUT

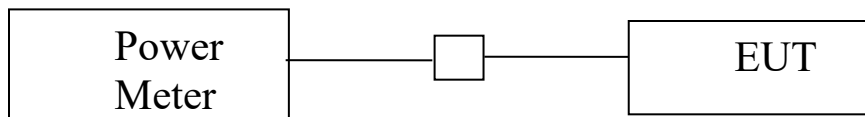

9.4 TEST RESULT AND DATA

PASS

Please refer to following table.



Temperature :	22 °C	Humidity:	56%	Pressure:	101.45KPa
Test By:		Bing	Test Date :	July 25, 2018	
Frequency MHz		Data Rate Mbps	Peak Output Power dBm		Limit dBm
GFSK (Antenna Gain=0.2dBi)					
Low Channel:	2402	1	2.53		30
Middle Channel:	2440	1	2.47		30
High Channel:	2480	1	1.44		30



10. POWER SPECTRAL DENSITY

10.1 TEST LIMIT

The Maximum of Power Spectral Density Measurement is 8dBm

10.2 TEST PROCEDURES

- g. The transmitter output was connected to spectrum analyzer.
- h. The spectrum analyzer' s resolution bandwidth were set at 3KHz RBW and 30KHz VBW as that of the fundamental frequency. Set the sweep time=auto couple.
- i. The power spectral density was measured and recorded.

10.3 TEST SETUP LAYOUT

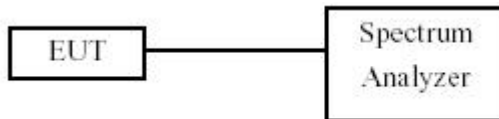

10.4 TEST RESULT AND DATA

PASS

Please refer to following table.



Temperature :	22 °C	Humidity:	56%	Pressure:	101.45KPa
Test By:	Bing		Test Date :	July 25, 2018	
Frequency MHz	Data Rate Mbps	PSD dBm/3kHz		Limit dBm/3kHz	
GFSK					
Low Channel: 2402	1	-16.015		8	
Middle Channel: 2440	1	-16.177		8	
High Channel: 2480	1	-17.505		8	



Low Channel

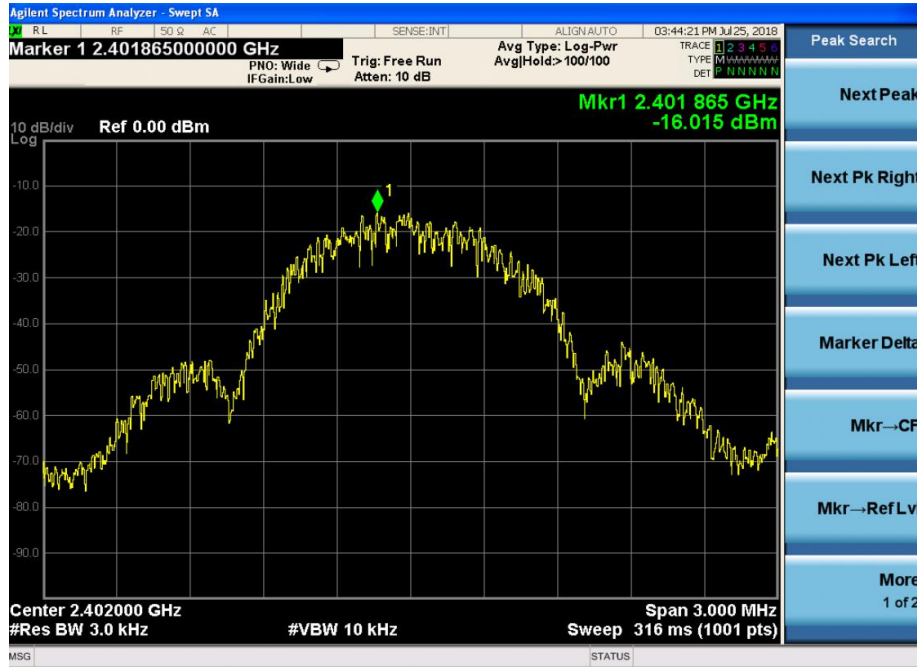

Middle Channel

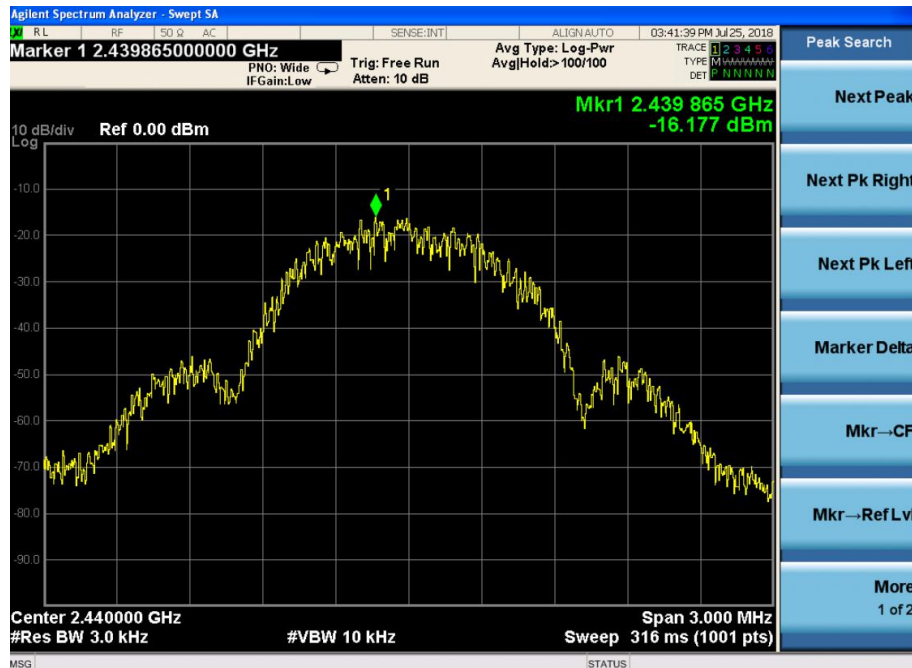



High Channel

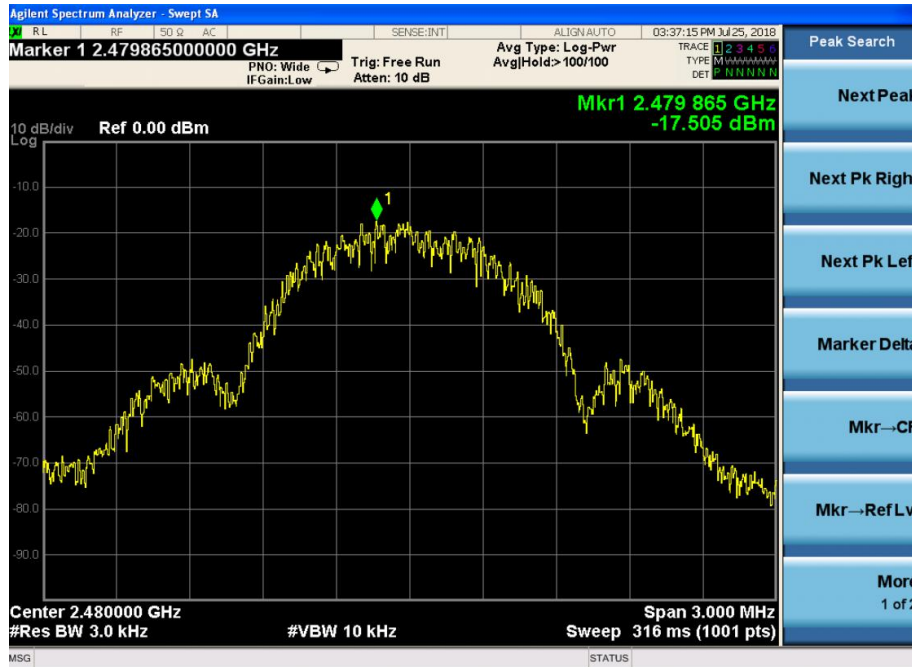



11. BAND EDGES MEASUREMENT

11.1 TEST LIMIT

Below - 20dB of the highest emission level of operating band (In 100 kHz Resolution Bandwidth)

11.2 TEST PROCEDURE

- a. The transmitter output was connected to the spectrum analyzer via a low loss cable.
- b. Set RBW of spectrum analyzer to 100 KHz and VBW of spectrum analyzer to 300 KHz with convenient frequency span including 100 KHz bandwidth from band edge.
- c. Peak conducted output power measured within any 100 kHz outside the authorized frequency band shall be attenuated by at least 20dB relative to the maximum measured in-band peak PSD level.
- d. The band edges was measured and recorded.

11.3 TEST SETUP LAYOUT

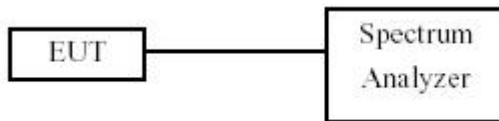

11.4 TEST RESULT AND DATA

PASS

Please refer to following table.



Low Channel

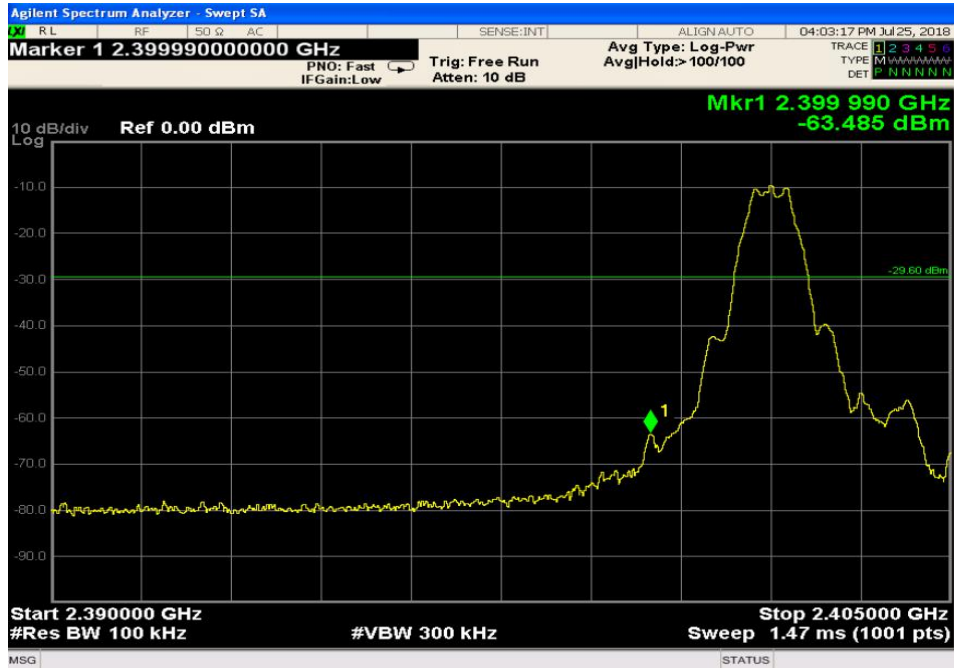

High Channel

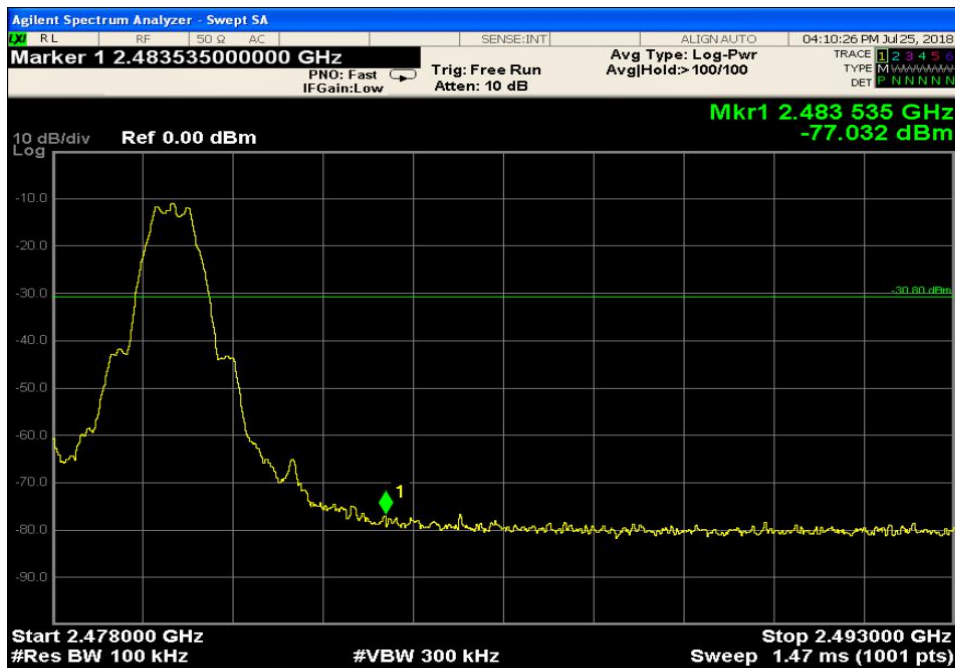



12. RESTRICTED BANDS OF OPERATION

Only spurious emissions are permitted in any of the frequency bands listed below:

MHz	MHz	MHz	GHz
0.09000 – 0.11000	16.42000 – 16.42300	399.9 – 410.0	4.500 – 5.150
0.49500 – 0.505**	16.69475 – 16.69525	608.0 – 614.0	5.350 – 5.460
2.17350 – 2.19050	16.80425 – 16.80475	960.0 – 1240.0	7.250 – 7.750
4.12500 – 4.12800	25.50000 – 25.67000	1300.0 – 1427.0	8.025 – 8.500
4.17725 – 4.17775	37.50000 – 38.25000	1435.0 – 1626.5	9.000 – 9.200
4.20725 – 4.20775	73.00000 – 74.60000	1645.5 – 1646.5	9.300 – 9.500
6.21500 – 6.21800	74.80000 – 75.20000	1660.0 – 1710.0	10.600 – 12.700
6.26775 – 6.26825	108.00000 – 121.94000	1718.8 – 1722.2	13.250 – 13.400
6.31175 – 6.31225	123.00000 – 138.00000	2200.0 – 2300.0	14.470 – 14.500
8.29100 – 8.29400	149.90000 – 150.05000	2310.0 – 2390.0	15.350 – 16.200
8.36200 – 8.36600	156.52475 – 156.52525	2483.5 – 2500.0	17.700 – 21.400
8.37625 – 8.38675	156.70000 – 156.90000	2655.0 – 2900.0	22.010 – 23.120
8.41425 – 8.41475	162.01250 – 167.17000	3260.0 – 3267.0	23.600 – 24.000
12.29000 – 12.29300	167.72000 – 173.20000	3332.0 – 3339.0	31.200 – 31.800
12.51975 – 12.52025	240.00000 – 285.00000	3345.8 – 3358.0	36.430 – 36.500
12.57675 – 12.57725	322.00000 – 335.40000	3600.0 – 4400.0	Above 38.6
13.36000 – 13.41000			

** : Until February 1, 1999, this restricted band shall be 0.490-0.510 MHz

12.1 LABELING REQUIREMENT

The device shall bear the following statement in a conspicuous location on the device: This device complies with part 15 of the FCC Rules. Operation is subject to the following two conditions: (1) This device may not cause harmful interference, and (2) this device must accept any interference received, including interference that may cause undesired operation.

--END---