



TEST REPORT

FCC Part 22 Subpart H / Part 24 Subpart E

Report Reference No. : **CTL1810196061-WF04**

Compiled by: (position+printed name+signature)	Happy Guo (File administrators)	<u>Happy Guo</u>
Tested by: (position+printed name+signature)	Nice Nong (Test Engineer)	<u>Nice Nong</u>
Approved by: (position+printed name+signature)	Ivan Xie (Manager)	<u>Ivan Xie</u>

Product Name	Langie Speaking Translator
Model/Type reference	S2
List Model(s)	S2-i, S2-a, S2-x, S2-n, S2-b
Trade Mark	Langie
FCC ID	2AOZK-S2
Applicant's name	Comet Innovation Limited
Address of applicant	Unit 1204, Winful Centre, 30 Shing Yip Street, Kwun Tong, Kowloon, Hong Kong
Test Firm	Shenzhen CTL Testing Technology Co., Ltd.
Address of Test Firm	Floor 1-A, Baisha Technology Park, No.3011, Shahexi Road, Nanshan District, Shenzhen, China 518055
Test specification	
Standard	FCC CFR Title 47 Part 2, Part 22H and Part 24E EIA/TIA 603-D: 2010 KDB 971168 D01
TRF Originator	Shenzhen CTL Testing Technology Co., Ltd.
Master TRF	Dated 2011-01
Date of Receipt	Oct. 23, 2018
Date of Test Date	Oct. 23, 2018 – Dec. 09, 2018
Data of Issue	Dec. 10, 2018
Result	Pass

Shenzhen CTL Testing Technology Co., Ltd. All rights reserved.

This publication may be reproduced in whole or in part for non-commercial purposes as long as the Shenzhen CTL Testing Technology Co., Ltd. is acknowledged as copyright owner and source of the material. Shenzhen CTL Testing Technology Co., Ltd. takes no responsibility for and will not assume liability for damages resulting from the reader's interpretation of the reproduced material due to its placement and context.

TEST REPORT

Test Report No. : CTL1810196061-WF04	Dec. 10, 2018
	Date of issue

Equipment under Test : Langie Speaking Translator

Model /Type : S2

Listed Models : S2-i, S2-a, S2-x, S2-n, S2-b

Applicant : **Comet Innovation Limited**

Address : Unit 1204, Winful Centre, 30 Shing Yip Street, Kwun Tong, Kowloon, Hong Kong

Manufacturer : **Comet Innovation Limited**

Address : Unit 1204, Winful Centre, 30 Shing Yip Street, Kwun Tong, Kowloon, Hong Kong

Test result	Pass *
--------------------	---------------

* In the configuration tested, the EUT complied with the standards specified page 5.

The test report merely corresponds to the test sample.

It is not permitted to copy extracts of these test result without the written permission of the test laboratory.

Contents

- 1 SUMMARY 5**
 - 1.1 TEST STANDARDS 5
 - 1.2 TEST DESCRIPTION 5
 - 1.3 TEST FACILITY 6
 - 1.4 STATEMENT OF THE MEASUREMENT UNCERTAINTY 6

- 2 GENERAL INFORMATION 7**
 - 2.1 ENVIRONMENTAL CONDITIONS 7
 - 2.2 GENERAL DESCRIPTION OF EUT 7
 - 2.3 DESCRIPTION OF TEST MODES AND TEST FREQUENCY 8
 - 2.4 EQUIPMENTS USED DURING THE TEST 9
 - 2.5 RELATED SUBMITTAL(S) / GRANT (S) 9
 - 2.6 MODIFICATIONS 9

- 3 TEST CONDITIONS AND RESULTS 10**
 - 3.1 OUTPUT POWER 10
 - 3.2 OCCUPIED BANDWIDTH 15
 - 3.3 BAND EDGE COMPLIANCE 19
 - 3.4 SPURIOUS EMISSION 23
 - 3.5 FREQUENCY STABILITY UNDER TEMPERATURE & VOLTAGE VARIATIONS 36

- 4 TEST SETUP PHOTOS OF THE EUT 39**

- 5 PHOTOS OF THE EUT 40**

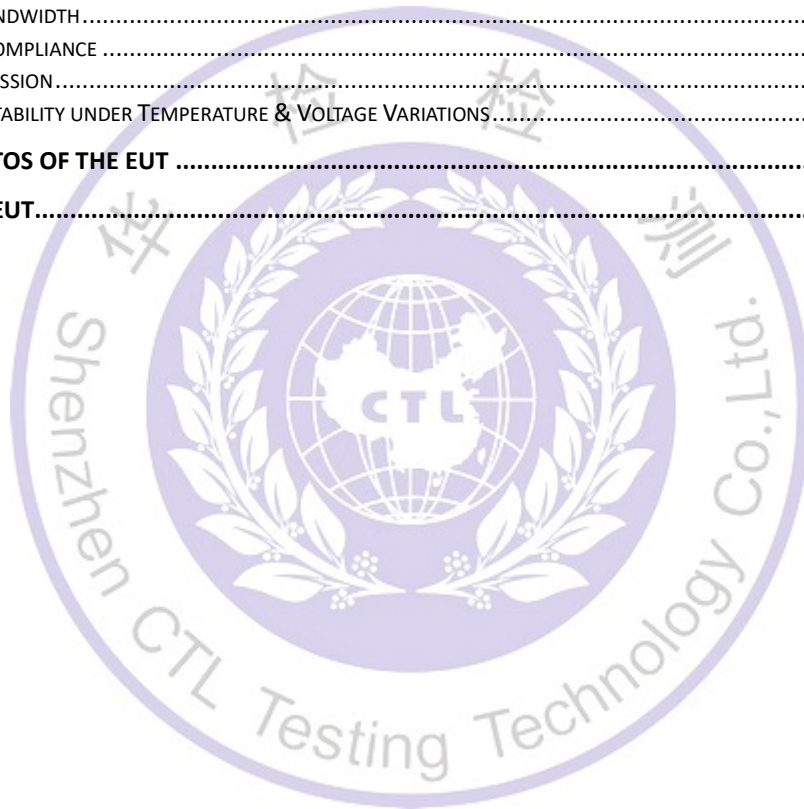

1 SUMMARY

1.1 TEST STANDARDS

The tests were performed according to following standards:

FCC Part 22: PRIVATE LAND MOBILE RADIO SERVICES.

FCC Part 24: PUBLIC MOBILE SERVICES

TIA/EIA 603 D June 2010: Land Mobile FM or PM Communications Equipment Measurement and Performance Standards.

FCC Part 2: FREQUENCY ALLOCATIONS AND RADIO TREATY MATTERS; GENERAL RULES AND REGULATIONS

KDB971168 D01:v02r02 MEASUREMENT GUIDANCE FOR CERTIFICATION OF LICENSED DIGITAL TRANSMITTERS

ANSI C63.10-2013 Methods of Measurement of Radio-Noise Emissions from Low-Voltage Electrical and Electronic Equipment in the Range of 9 kHz to 40 GHz

1.2 Test Description

Test Item	Section in CFR 47	Result
RF Output Power	Part 2.1046 Part 22.913 (a)(2) Part 24.232 (c)	Pass
Peak-to-Average Ratio	Part 24.232 (d)	Pass
99% & -26 dB Occupied Bandwidth	Part 2.1049 Part 22.917 Part 24.238	Pass
Spurious Emissions at Antenna Terminal	Part 2.1051 Part 22.917 (a) Part 24.238 (a)	Pass
Field Strength of Spurious Radiation	Part 2.1053 Part 22.917 (a) Part 24.238 (a)	Pass
Out of band emission, Band Edge	Part 22.917 (a) Part 24.238 (a)	Pass
Frequency stability	Part 2.1055 Part 22.355 Part 24.235	Pass

1.3 Test Facility

1.3.1 Address of the test laboratory

Shenzhen CTL Testing Technology Co., Ltd.

Floor 1-A, Baisha Technology Park, No. 3011, Shahexi Road, Nanshan, Shenzhen 518055 China

The 3m-Semi anechoic test site fulfils CISPR 16-1-4 according to ANSI C63.4:2014 and CISPR 16-1-4:2010 SVSWR requirement for radiated emission above 1GHz.

1.3.2 Laboratory accreditation

The test facility is recognized, certified, or accredited by the following organizations:

IC Registration No.: 9618B

The 3m alternate test site of Shenzhen CTL Testing Technology Co., Ltd. EMC Laboratory has been registered by Certification and Engineer Bureau of Industry Canada for the performance of with Registration No.: 9618B on November 13, 2013.

FCC-Registration No.: 399832

Shenzhen CTL Testing Technology Co., Ltd. EMC Laboratory has been registered and fully described in a report filed with the (FCC) Federal Communications Commission. The acceptance letter from the FCC is maintained in our files. Registration 399832, December 08, 2017.

1.4 Statement of the measurement uncertainty

The data and results referenced in this document are true and accurate. The reader is cautioned that there may be errors within the calibration limits of the equipment and facilities. The measurement uncertainty was calculated for all measurements listed in this test report acc. to CISPR 16 - 4 „Specification for radio disturbance and immunity measuring apparatus and methods – Part 4: Uncertainty in EMC Measurements“ and is documented in the Shenzhen CTL Testing Technology Co., Ltd. quality system acc. to DIN EN ISO/IEC 17025. Furthermore, component and process variability of devices similar to that tested may result in additional deviation. The manufacturer has the sole responsibility of continued compliance of the device.

Hereafter the best measurement capability for CTL laboratory is reported:

Test	Range	Measurement Uncertainty	Notes
Radiated Emission	30~1000MHz	4.10dB	(1)
Radiated Emission	Above 1GHz	4.32dB	(1)
Conducted Disturbance	0.15~30MHz	3.20dB	(1)

- (1) This uncertainty represents an expanded uncertainty expressed at approximately the 95% confidence level using a coverage factor of k=2.

2 GENERAL INFORMATION

2.1 Environmental conditions

During the measurement the environmental conditions were within the listed ranges:

Normal Temperature:	25°C
Relative Humidity:	55 %
Air Pressure:	101 kPa

2.2 General Description of EUT

Product Name:	Langie Speaking Translator
Model/Type reference:	S2
Power supply:	DC 3.7V from battery
2G	
Operation Band:	GSM850, PCS1900
Supported Type:	GPRS/EGPRS
Power Class:	GSM850:Power Class 4 PCS1900:Power Class 1
Modulation Type:	GMSK for GPRS, 8PSK for EGPRS
GSM Release Version	R99
GPRS Multislot Class	12
EGPRS Multislot Class	12
WCDMA	
Operation Band:	FDD Band II & Band V
Power Class:	Power Class 3
Modulation Type:	QPSK for WCDMA/HSUPA/HSDPA
WCDMA Release Version:	R99
HSDPA Release Version:	Release 7, CAT14
HSUPA Release Version:	Release 6, CAT6
DC-HSUPA Release Version:	Not Supported

Note: For more details, refer to the user's manual of the EUT.

2.3 Description of Test Modes and Test Frequency

The EUT has been tested under typical operating condition. The CUM200 used to control the EUT staying in continuous transmitting and receiving mode for testing. Regards to the frequency band operation: the lowest, middle and highest frequency of channel were selected to perform the test, then shown on this report.

Test Frequency:

GSM 850		PCS1900	
Channel	Frequency (MHz)	Channel	Frequency (MHz)
128	824.20	512	1850.20
190	836.60	661	1880.00
251	848.80	810	1909.80

FDD Band II		FDD Band V	
Channel	Frequency (MHz)	Channel	Frequency (MHz)
9262	1852.4	4132	826.40
9400	1880.0	4182	836.60
9538	1907.6	4233	846.60

Test Modes:

The test mode(s) are selected according to relevant radio technology specifications.

Test Mode	Test Modes Description
Mode 1	GSM system, GPRS, GMSK modulation
Mode 2	GSM system, EDGE, GMSK modulation
Mode 3	WCDMA system, QPSK modulation
Mode 4	HSDPA system, QPSK modulation
Mode 5	HSUPA system, QPSK modulation

Note:

1. As GSM only support data transmit, only GPRS and EDGE test result recorded in this report.
2. As WCDMA, HSDPA and HSUPA with the same emission designator, test result recorded in this report at the worst case Mode 3 only after exploratory scan.

2.4 Equipments Used during the Test

Test Equipment	Manufacturer	Model No.	Serial No.	Calibration Date	Calibration Due Date
Bilog Antenna	Sunol Sciences Corp.	JB1	A061713	2018/06/01	2019/05/31
Bilog Antenna	Sunol Sciences Corp.	JB1	A061714	2018/06/01	2019/05/31
EMI Test Receiver	R&S	ESCI	103710	2018/05/20	2019/05/19
Spectrum Analyzer	Agilent	E4407B	MY41440676	2018/01/17	2019/01/16
Spectrum Analyzer	Agilent	N9020	US46220290	2018/05/20	2019/05/19
Controller	EM Electronics	Controller EM 1000	N/A	2018/05/18	2019/05/17
Horn Antenna	Sunol Sciences Corp.	DRH-118	A062013	2018/05/18	2019/05/17
Horn Antenna	Sunol Sciences Corp.	DRH-118	A062014	2018/05/18	2019/05/17
Active Loop Antenna	SCHWARZBEC K	FMZB1519	1519-037	2018/05/18	2019/05/17
Amplifier	Agilent	8449B	3008A02306	2018/05/18	2019/05/17
Amplifier	Agilent	8447D	2944A10176	2018/05/19	2019/05/18
Temperature/Humidity Meter	Gangxing	CTH-608	02	2018/10/16	2019/10/15
Radio Communication Tester	R&S	CMU200	115419	2018/05/19	2019/05/18
High-Pass Filter	K&L	9SH10-2700/X1 2750-O/O	N/A	2018/05/19	2019/05/18
High-Pass Filter	K&L	41H10-1375/U1 2750-O/O	N/A	2018/06/01	2019/05/31
RF Cable	HUBER+SUHN ER	RG214	N/A	2018/05/18	2019/05/17
Climate Chamber	ESPEC	EL-10KA	A20120523	2018/05/18	2019/05/17
SIGNAL GENERATOR	Agilent	E4421B	US40051744	2018/05/18	2019/05/17
Directional Coupler	Agilent	87300B	3116A03638	2018/06/01	2019/05/31

2.5 Related Submittal(s) / Grant (s)

This submittal(s) (test report) is intended for FCC ID: 2AOZK-S2 filing to comply with of the FCC Part 22 and Part 24 Rules.

2.6 Modifications

No modifications were implemented to meet testing criteria.

3 TEST CONDITIONS AND RESULTS

3.1 Output Power

LIMIT

GSM850/WCDMA Band V: 7W

PCS1900/WCDMA Band II: 2W

The Peak-to-Average Ratio (PAR) of the transmission may not exceed 13 dB.

TEST CONFIGURATION

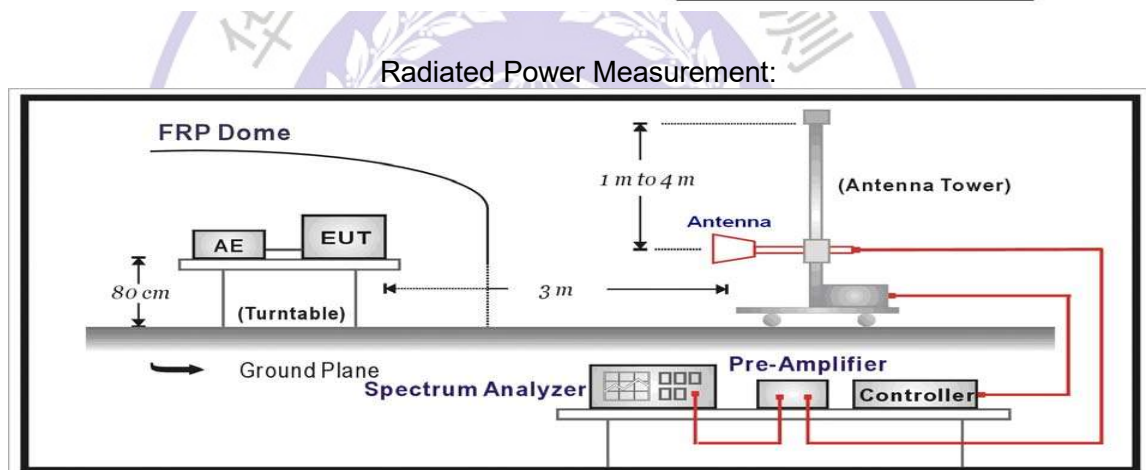
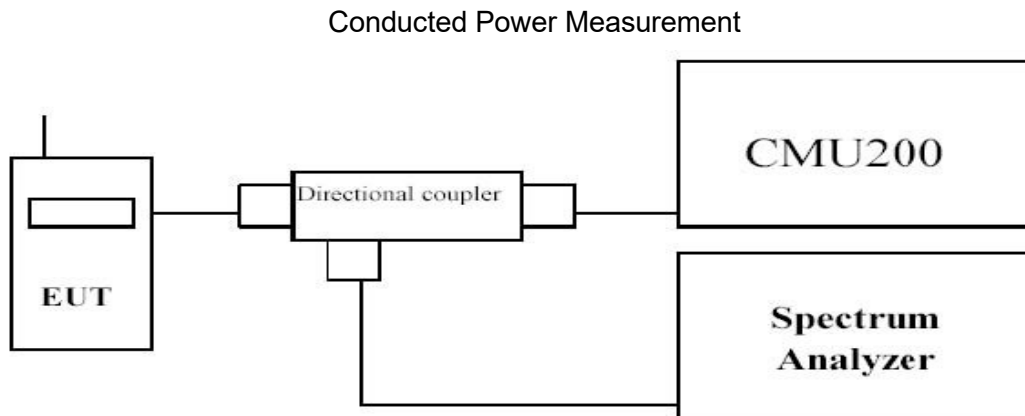

TEST PROCEDURE

The EUT was setup according to EIA/TIA 603C

Conducted Power Measurement:

- Place the EUT on a bench and set it in transmitting mode.
- Connect a low loss RF cable from the antenna port to a spectrum analyzer and CMU200 by a Directional Couple.
- EUT Communicate with CMU200 then selects a channel for testing.
- Add a correction factor to the display of spectrum, and then test.

Radiated Power Measurement:

- The EUT shall be placed at the specified height on a support, and in the position closest to normal use as declared by provider.
- The test antenna shall be oriented initially for vertical polarization and shall be chosen to correspond to the frequency of the transmitter

- c) The output of the test antenna shall be connected to the measuring receiver.
- d) The transmitter shall be switched on and the measuring receiver shall be tuned to the frequency of the transmitter under test.
- e) The test antenna shall be raised and lowered through the specified range of height until a maximum signal level is detected by the measuring receiver.
- f) The transmitter shall then be rotated through 360° in the horizontal plane, until the maximum signal level is detected by the measuring receiver.
- g) The test antenna shall be raised and lowered again through the specified range of height until a maximum signal level is detected by the measuring receiver.
- h) The maximum signal level detected by the measuring receiver shall be noted.
- i) The transmitter shall be replaced by a substitution antenna.
- j) The substitution antenna shall be orientated for vertical polarization and the length of the substitution antenna shall be adjusted to correspond to the frequency of the transmitter.
- k) The substitution antenna shall be connected to a calibrated signal generator.
- l) If necessary, the input attenuator setting of the measuring receiver shall be adjusted in order to increase the sensitivity of the measuring receiver.
- m) The test antenna shall be raised and lowered through the specified range of height to ensure that the maximum signal is received.
- n) The input signal to the substitution antenna shall be adjusted to the level that produces a level detected by the measuring receiver, that is equal to the level noted while the transmitter radiated power was measured, corrected for the change of input attenuator setting of the measuring receiver.
- o) The measurement shall be repeated with the test antenna and the substitution antenna orientated for horizontal polarization.
- p) The measure of the effective radiated power is the larger of the two levels recorded at the input to the substitution antenna, corrected for gain of the substitution antenna if necessary.

TEST RESULTS**Conducted Measurement:**

EUT Mode	Channel	Frequency (MHz)	Avg.Burst Power (dBm)	Peak-to-Average Ratio (dB)	Limit (dBm)	Result
GPRS 850 (GMSK)	128	824.20	31.46	/	38.45	Pass
	190	836.60	31.67	/		
	251	848.80	31.55	/		
EGPRS850 (GMSK, 1Slot)	128	824.20	31.20	/	38.45	Pass
	190	836.60	31.34	/		
	251	848.80	31.50	/		
EGPRS850 (8PSK, 1Slot)	128	824.20	31.41	/	38.45	Pass
	190	836.60	31.55	/		
	251	848.80	31.67	/		
GPRS1900 (GMSK)	512	1850.20	28.67	0.49	33.01	Pass
	661	1880.00	28.79	0.68		
	810	1909.80	28.33	0.35		
EGPRS1900 (GMSK, 1Slot)	512	1850.20	28.16	0.41	33.01	Pass
	661	1880.00	28.40	0.62		
	810	1909.80	28.55	0.69		
EGPRS1900 (8PSK, 1Slot)	512	1850.20	28.53	0.36	33.01	Pass
	661	1880.00	28.63	0.74		
	810	1909.80	28.27	-0.52		
WCDMA Band II (QPSK)	9262	1852.40	24.50	3.34	33.01	Pass
	9400	1880.00	24.65	3.48		
	9538	1907.60	24.80	3.31		
WCDMA Band V (QPSK)	4132	826.40	23.86	/	38.45	Pass
	4183	836.60	23.73	/		
	4233	846.60	23.69	/		

Note: 1. Peak-to-Average Ratio= maximum PK burst power-maximum Avg. burst power.

Radiated Measurement:

Note: 1. The field strength of radiation emission was measured in the following position: EUT stand-up position (Zaxis), lie-down position (X, Y axis). The data show in this report only with the worst case setup. After exploratory measurement the worst case of Z axis was reported.

Note: 2. We test the H direction and V direction and V direction is worse.

GPRS850

Channel	P _{Mea} (dBm)	P _{cl} (dB)	G _a Antenna Gain(dB)	Correction (dB)	P _{Ag} (dB)	ERP (dBm)	Limit (dBm)	Margin (dB)	Polarization
128	-11.30	2.42	8.45	2.15	36.82	29.40	38.45	9.05	V
190	-10.97	2.46	8.45	2.15	36.82	29.69	38.45	8.76	V
251	-11.12	2.53	8.36	2.15	36.82	29.38	38.45	9.07	V

EGPRS850

Channel	P _{Mea} (dBm)	P _{cl} (dB)	G _a Antenna Gain(dB)	Correction (dB)	P _{Ag} (dB)	ERP (dBm)	Limit (dBm)	Margin (dB)	Polarization
128	-11.38	2.42	8.45	2.15	36.82	29.32	38.45	9.13	V
190	-11.28	2.46	8.45	2.15	36.82	29.38	38.45	9.07	V
251	-10.95	2.53	8.36	2.15	36.82	29.55	38.45	8.90	V

GPRS1900

Channel	P _{Mea} (dBm)	P _{cl} (dB)	G _a Antenna Gain(dB)	P _{Ag} (dB)	EIRP (dBm)	Limit (dBm)	Margin (dB)	Polarization
512	-12.63	3.41	10.24	33.6	27.80	33.01	5.21	V
661	-12.58	3.49	10.24	33.6	27.77	33.01	5.24	V
810	-12.42	3.55	10.23	33.6	27.86	33.01	5.15	V

EGPRS1900

Channel	P _{Mea} (dBm)	P _{cl} (dB)	G _a Antenna Gain(dB)	P _{Ag} (dB)	EIRP (dBm)	Limit (dBm)	Margin (dB)	Polarization
512	-13.64	3.41	10.24	33.6	26.79	33.01	6.22	V
661	-13.50	3.49	10.24	33.6	26.85	33.01	6.16	V
810	-13.73	3.55	10.23	33.6	26.55	33.01	6.46	V

WCDMA BAND II

Channel	P _{Mea} (dBm)	P _{cl} (dB)	G _a Antenna Gain(dB)	P _{Ag} (dB)	EIRP (dBm)	Limit (dBm)	Margin (dB)	Polarization
9262	-19.19	3.42	10.24	33.6	21.23	33.01	11.78	V
9400	-19.09	3.49	10.24	33.6	21.26	33.01	11.75	V
9538	-18.96	3.54	10.23	33.6	21.33	33.01	11.68	V

WCDMA BAND V

Channel	P _{Mea} (dBm)	P _{cl} (dB)	G _a Antenna Gain(dB)	Correction (dB)	P _{Ag} (dB)	ERP (dBm)	Limit (dBm)	Margin (dB)	Polarization
4132	-19.49	2.43	8.45	2.15	36.82	21.20	38.45	17.25	V
4183	-20.43	2.46	8.45	2.15	36.82	20.23	38.45	18.22	V
4233	-20.23	2.52	8.36	2.15	36.82	20.28	38.45	18.17	V

Remark:

1. $EIRP = P_{Mea}(dBm) - P_{cl}(dB) + P_{Ag}(dB) + G_a(dBi)$
2. $ERP = EIRP - 2.15dBi$ as EIRP by subtracting the gain of the dipole.



3.2 Occupied Bandwidth

LIMIT

N/A

TEST CONFIGURATION

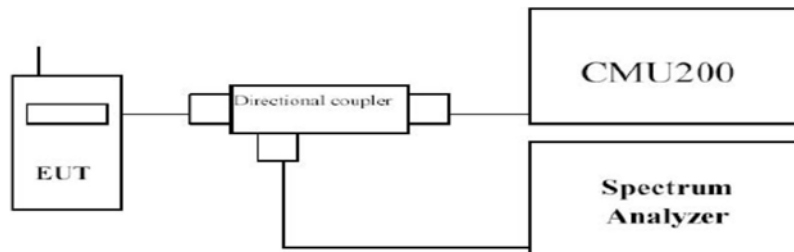

TEST PROCEDURE

1. The EUT's output RF connector was connected with a short cable to the spectrum analyzer
2. RBW was set to about 1% of emission BW, VBW \geq 3 times RBW.
3. -26dBc display line was placed on the screen (or 99% bandwidth), the occupied bandwidth is the delta frequency between the two points where the display line intersects the signal trace.

TEST RESULTS

EUT Mode	Channel	Frequency (MHz)	99% Occupy bandwidth (KHz)	-26dB bandwidth (KHz)
GPRS850 (GMSK)	128	824.20	243.62	314.70
	190	836.60	245.94	314.90
	251	848.80	246.88	316.40
EGPRS850 (8PSK,1Slot)	128	824.20	245.51	312.90
	190	836.60	244.86	316.00
	251	848.80	247.32	316.40
GPRS1900 (GMSK)	512	1850.20	245.75	312.40
	661	1880.00	244.58	313.10
	810	1909.80	243.33	311.40
EGPRS1900 (8PSK,1Slot)	512	1850.20	244.18	311.10
	661	1880.00	244.74	310.50
	810	1909.80	247.48	315.90
WCDMA Band II (QPSK)	9262	1852.4	4169.80	4666.00
	9400	1880.0	4159.00	4665.00
	9538	1907.6	4166.60	4691.00
WCDMA Band V (QPSK)	4132	826.4	4168.30	4653.00
	4183	836.6	4148.30	4636.00
	4233	846.6	4161.20	4645.00

Test plots as follow:

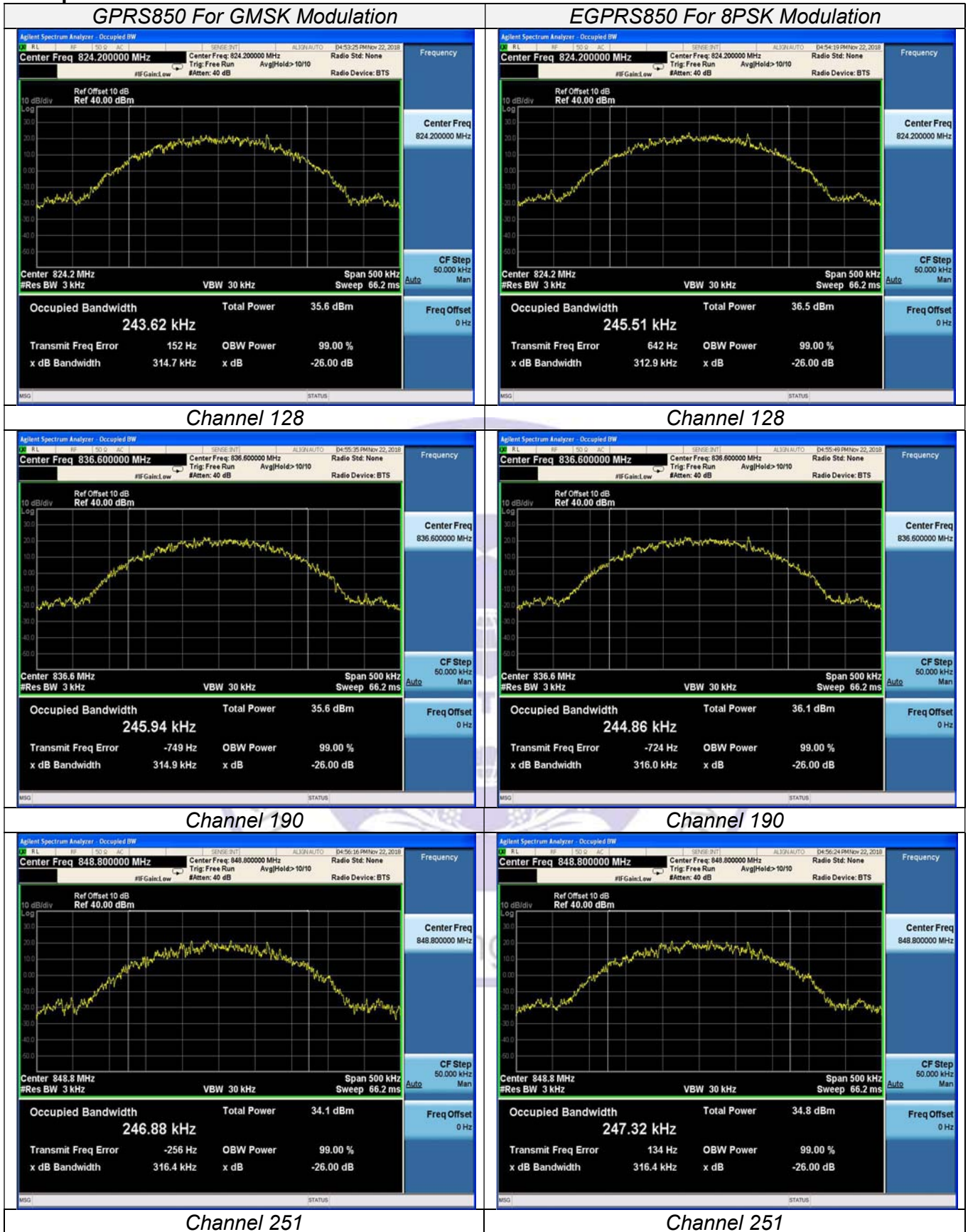

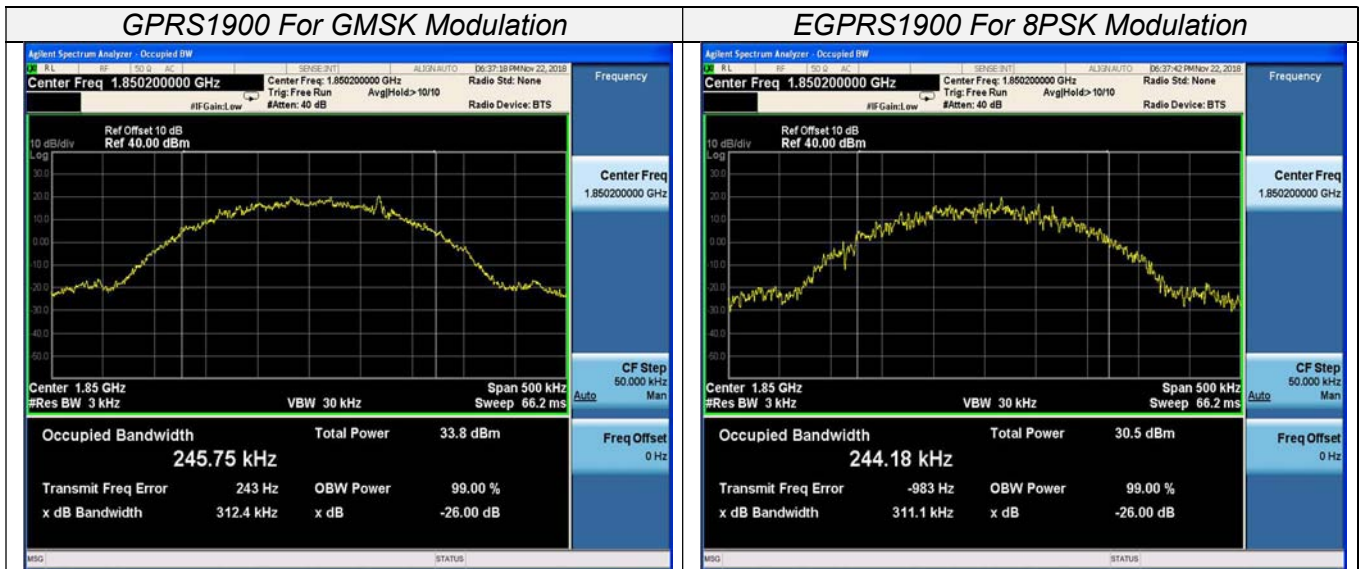

Channel 512

Channel 512

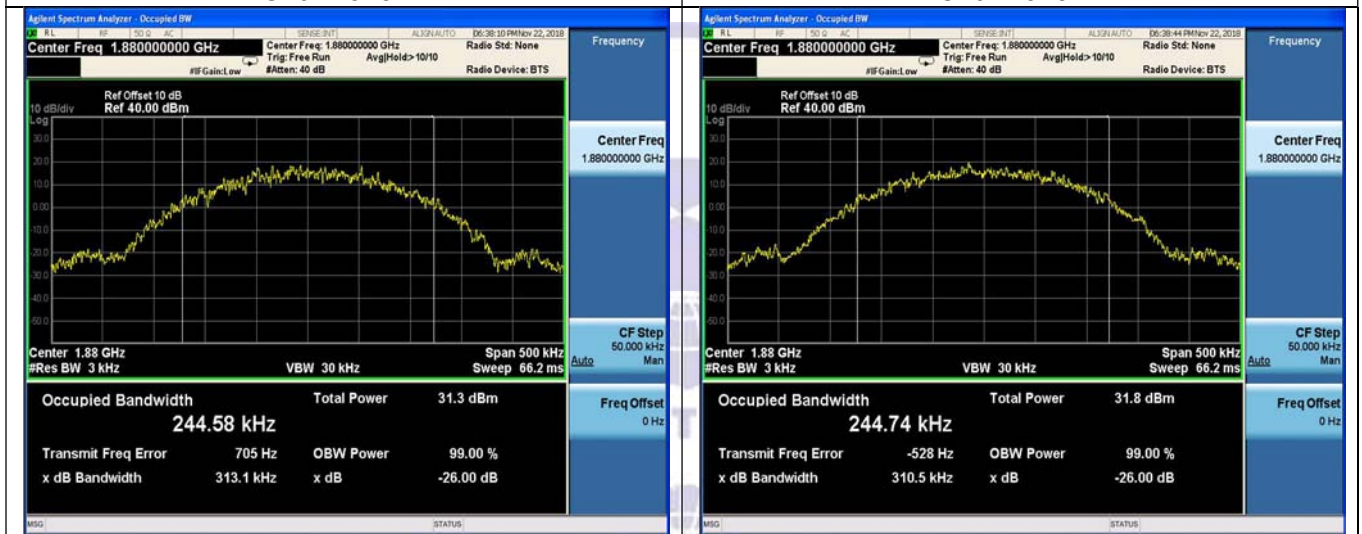

Channel 661

Channel 661

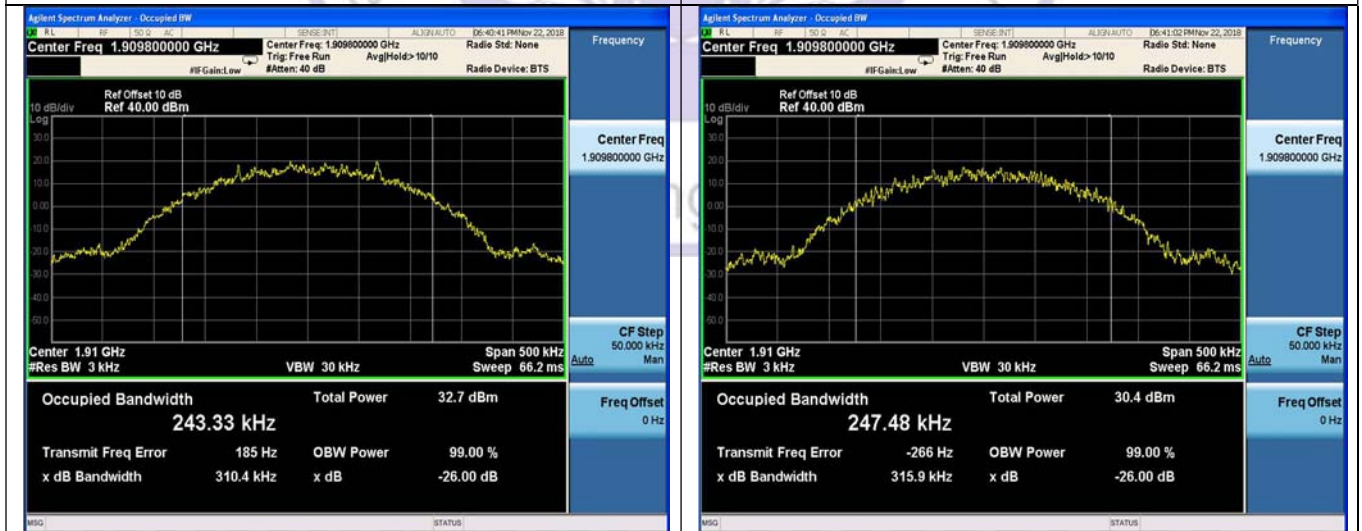

Channel 810

Channel 810

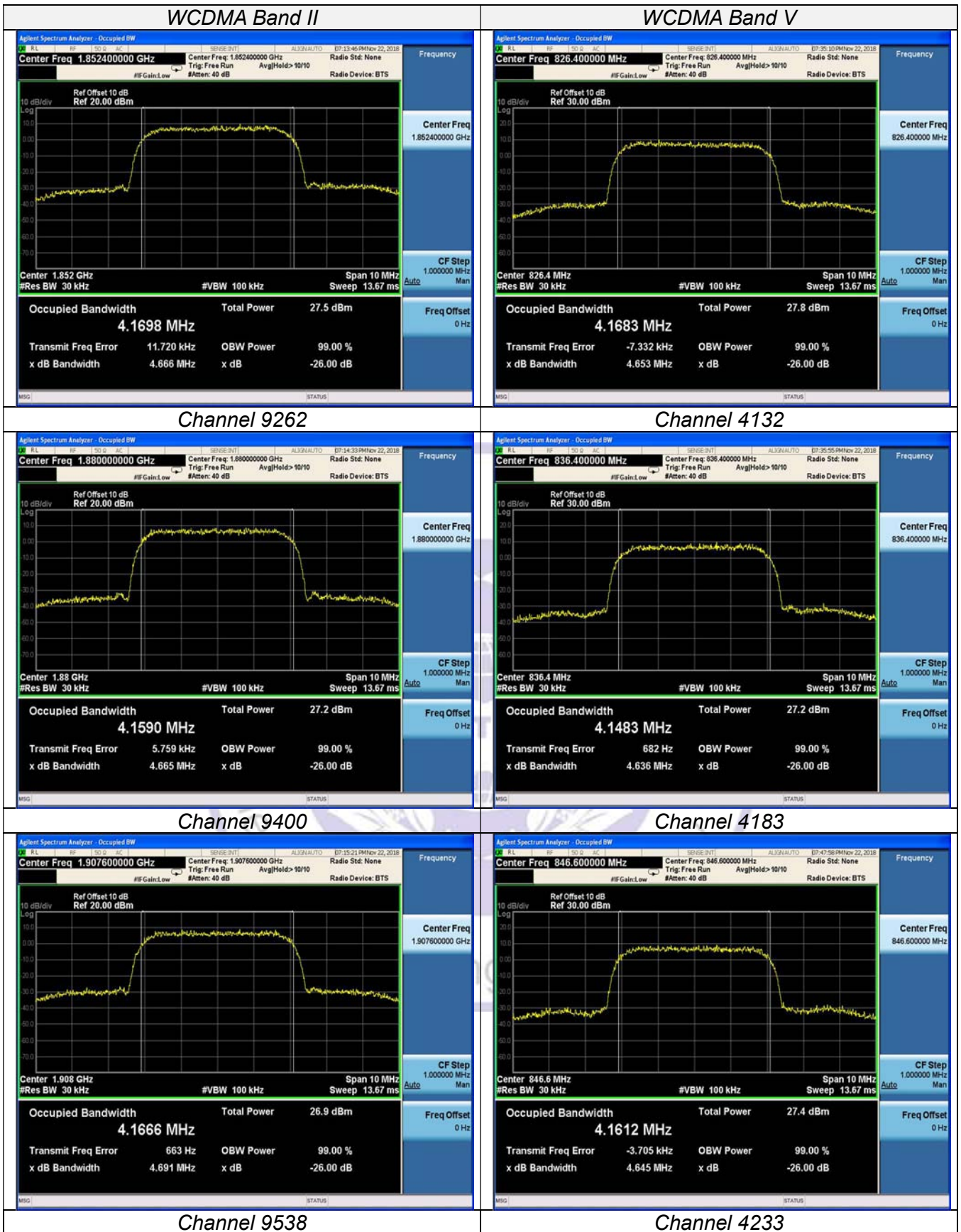

3.3 Band Edge compliance

LIMIT

The power of any emission outside of the authorized operating frequency ranges must be attenuated below the transmitting power (P) by a factor of at least $43 + 10\log(P)$ dB.

TEST CONFIGURATION

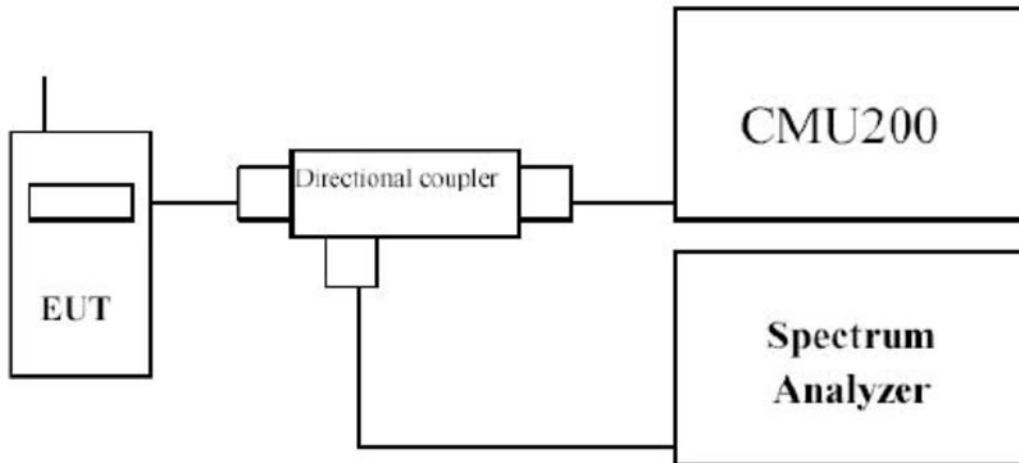

TEST PROCEDURE

In the 1MHz bands immediately outside and adjacent to the frequency block a resolution bandwidth of at least one percent of the emission bandwidth of the fundamental emission of the transmitter may be employed to measure the out of band Emissions.

TEST RESULTS

GPRS850					
Channel Number	Frequency (MHz)	Max Measurement Results		Limit (dBm)	Verdict
		Frequency (MHz)	Values (dBm)		
128	824.20	823.995	-27.564	-13.00	Pass
251	848.80	849.017	-25.077	-13.00	Pass

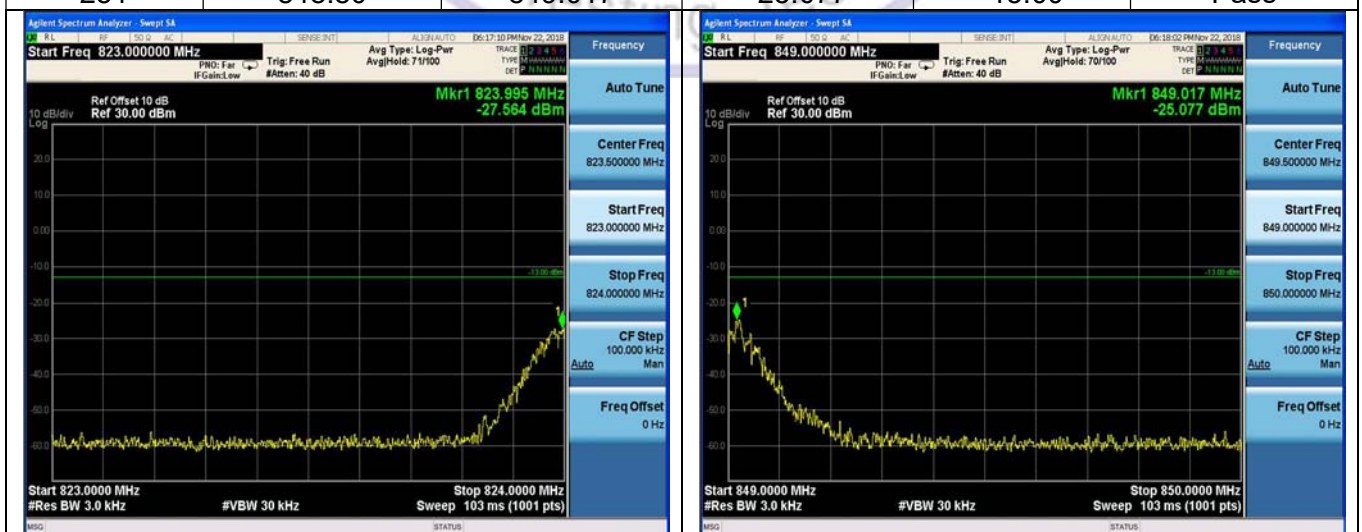

EGPRS850					
Channel Number	Frequency (MHz)	Measurement Results		Limit (dBm)	Verdict
		Frequency (MHz)	Values (dBm)		
128	824.20	823.982	-24.997	-13.00	Pass
251	848.80	849.021	-24.144	-13.00	Pass

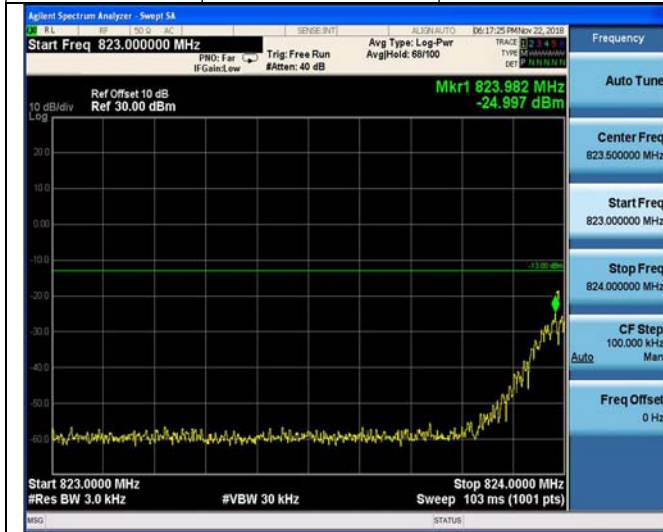

GPRS1900					
Channel Number	Frequency (MHz)	Measurement Results		Limit (dBm)	Verdict
		Frequency (MHz)	Values (dBm)		
512	1850.20	1849.996	-27.915	-13.00	Pass
810	1909.80	1910.016	-27.523	-13.00	Pass

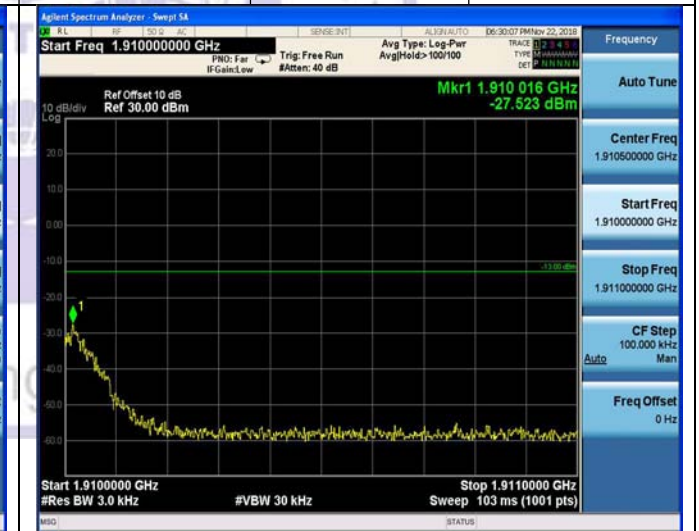
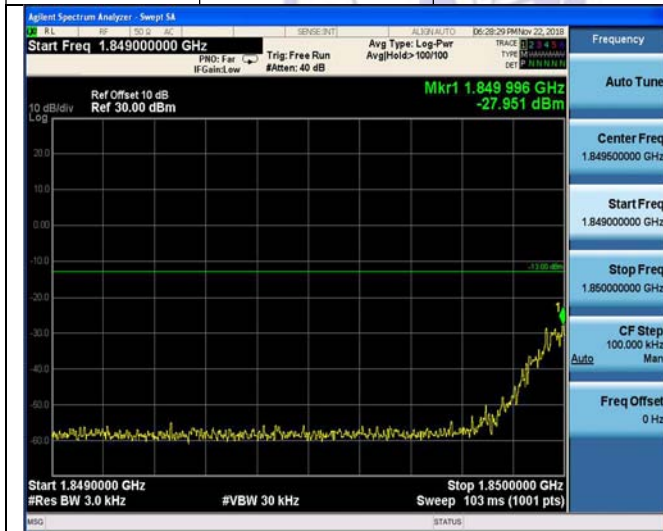

EGPRS1900					
Channel Number	Frequency (MHz)	Measurement Results		Limit (dBm)	Verdict
		Frequency (MHz)	Values (dBm)		
512	1850.20	1849.998	-26.707	-13.00	Pass
810	1909.80	1910.018	-27.981	-13.00	Pass

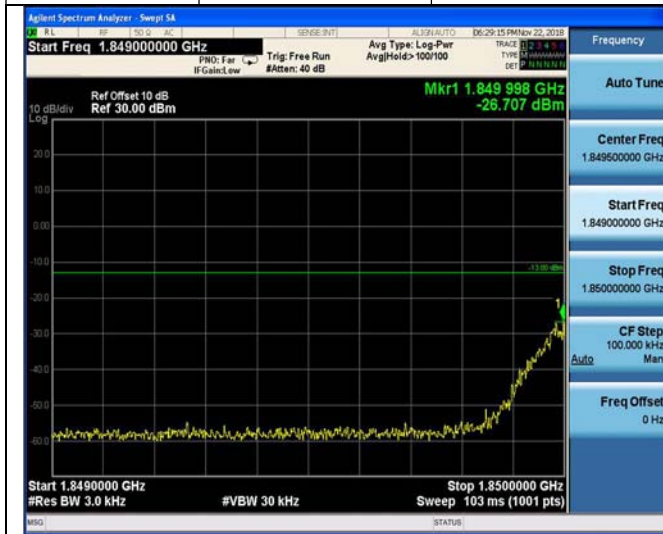

WCDMA Band II					
Channel Number	Frequency (MHz)	Measurement Results		Limit (dBm)	Verdict
		Frequency (MHz)	Values (dBm)		
9262	1852.4	1850.000	-23.977	-13.00	Pass
9538	1907.6	1910.001	-23.151	-13.00	Pass

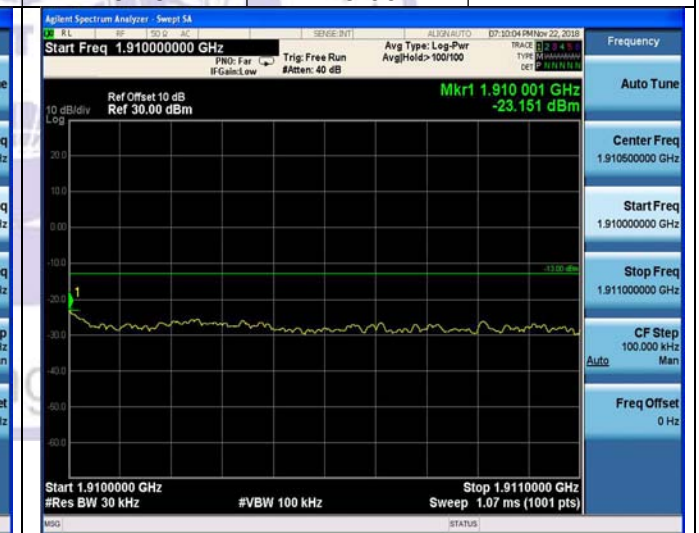

WCDMA Band V					
Channel Number	Frequency (MHz)	Measurement Results		Limit (dBm)	Verdict
		Frequency (MHz)	Values (dBm)		
4132	826.4	824.000	-23.755	-13.00	Pass
4233	846.6	849.002	-24.801	-13.00	Pass

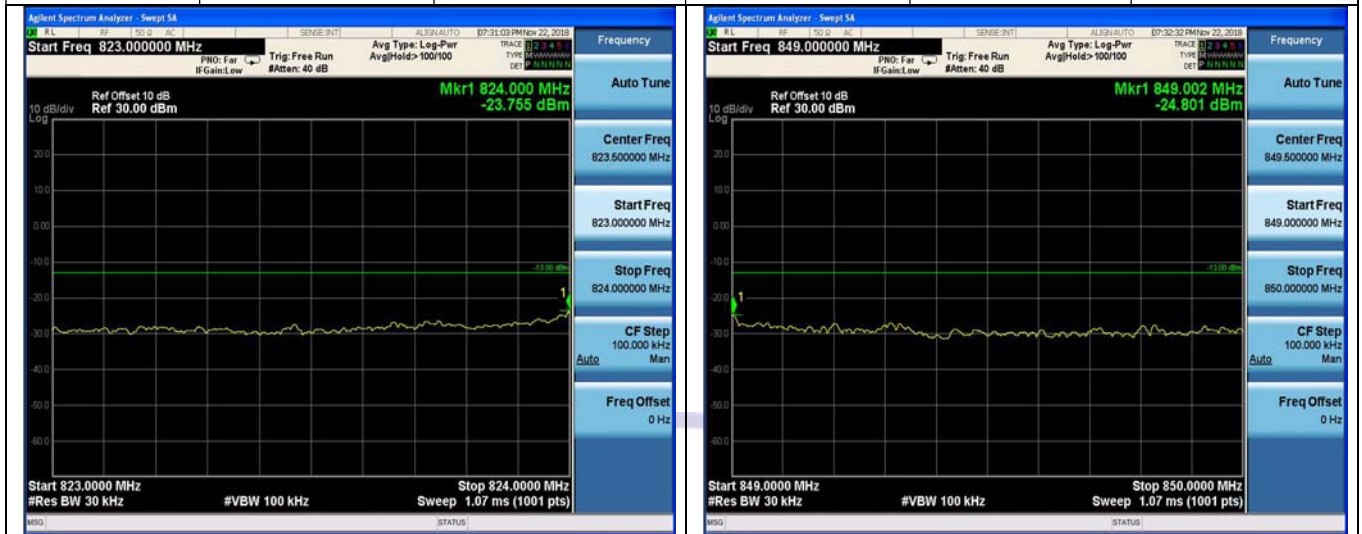

3.4 Spurious Emission

LIMIT

The power of any emission outside of the authorized operating frequency ranges must be attenuated below the transmitting power (P) by a factor of at least $43 + 10\log(P)$ dB.

TEST CONFIGURATION

Conducted Spurious Measurement:

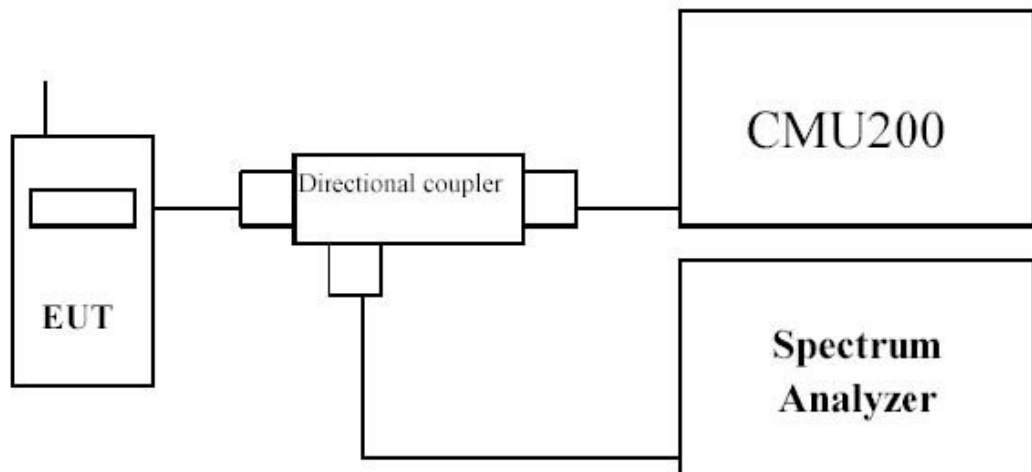

Radiated Spurious Measurement:

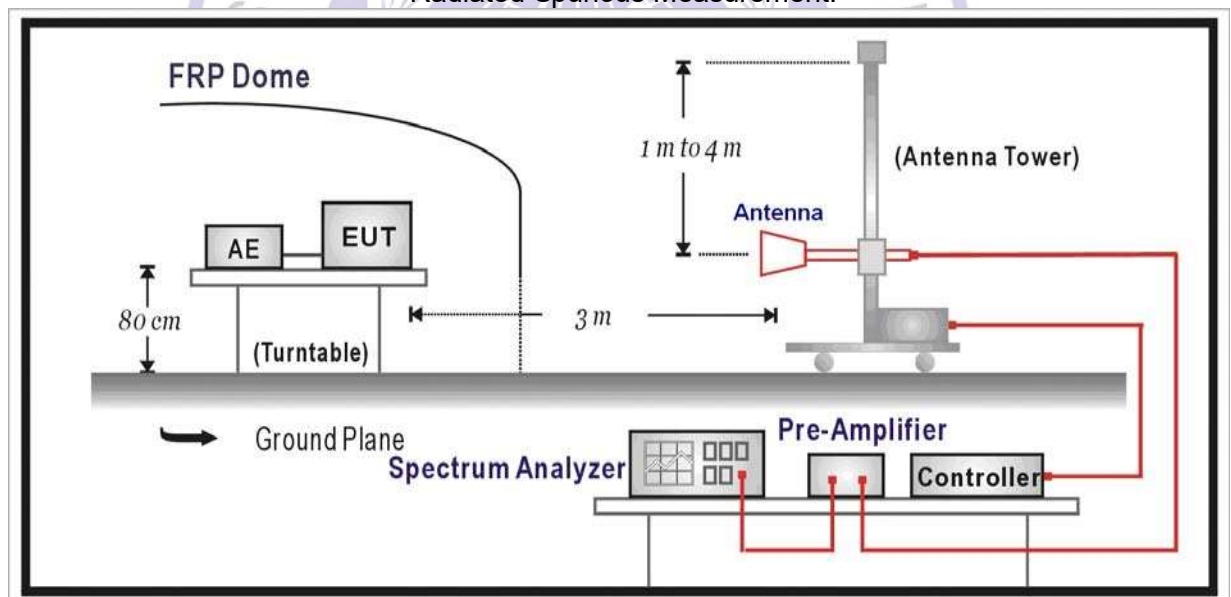

TEST PROCEDURE

The EUT was setup according to EIA/TIA 603C

Conducted Spurious Measurement:

- Place the EUT on a bench and set it in transmitting mode.
- Connect a low loss RF cable from the antenna port to a spectrum analyzer and CMU200 by a Directional Couple.
- EUT Communicate with CMU200 then selects a channel for testing.

- d) Add a correction factor to the display of spectrum, and then test.
- e) The resolution bandwidth of the spectrum analyzer was set at 1MHz for Part 22 and 1MHz for Part 24, sufficient scans were taken to show the out of band Emission if any up to 10th harmonic.

Radiated Spurious Measurement:

- a) The EUT shall be placed at the specified height on a support, and in the position closest to normal use as declared by provider.
- b) The test antenna shall be oriented initially for vertical polarization and shall be chosen to correspond to the frequency of the transmitter
- c) The output of the test antenna shall be connected to the measuring receiver.
- d) The transmitter shall be switched on and the measuring receiver shall be tuned to the frequency of the transmitter under test.
- e) The test antenna shall be raised and lowered through the specified range of height until a maximum signal level is detected by the measuring receiver.
- f) The transmitter shall then be rotated through 360° in the horizontal plane, until the maximum signal level is detected by the measuring receiver.
- g) The test antenna shall be raised and lowered again through the specified range of height until a maximum signal level is detected by the measuring receiver.
- h) The maximum signal level detected by the measuring receiver shall be noted.
- i) The transmitter shall be replaced by a substitution antenna.
- j) The substitution antenna shall be orientated for vertical polarization and the length of the substitution antenna shall be adjusted to correspond to the frequency of the transmitter.
- k) The substitution antenna shall be connected to a calibrated signal generator.
- l) If necessary, the input attenuator setting of the measuring receiver shall be adjusted in order to increase the sensitivity of the measuring receiver.
- m) The test antenna shall be raised and lowered through the specified range of height to ensure that the maximum signal is received.
- n) The input signal to the substitution antenna shall be adjusted to the level that produces a level detected by the measuring receiver, that is equal to the level noted while the transmitter radiated power was measured, corrected for the change of input attenuator setting of the measuring receiver.
- o) The measurement shall be repeated with the test antenna and the substitution antenna orientated for horizontal polarization.
- p) The measure of the effective radiated power is the larger of the two levels recorded at the input to the substitution antenna, corrected for gain of the substitution antenna if necessary.
- q) The resolution bandwidth of the spectrum analyzer was set at 100 kHz for Part 22 and 1MHz for Part 24. The frequency range was checked up to 10th harmonic.

TEST RESULTS

Conducted Measurement:

GPRS850

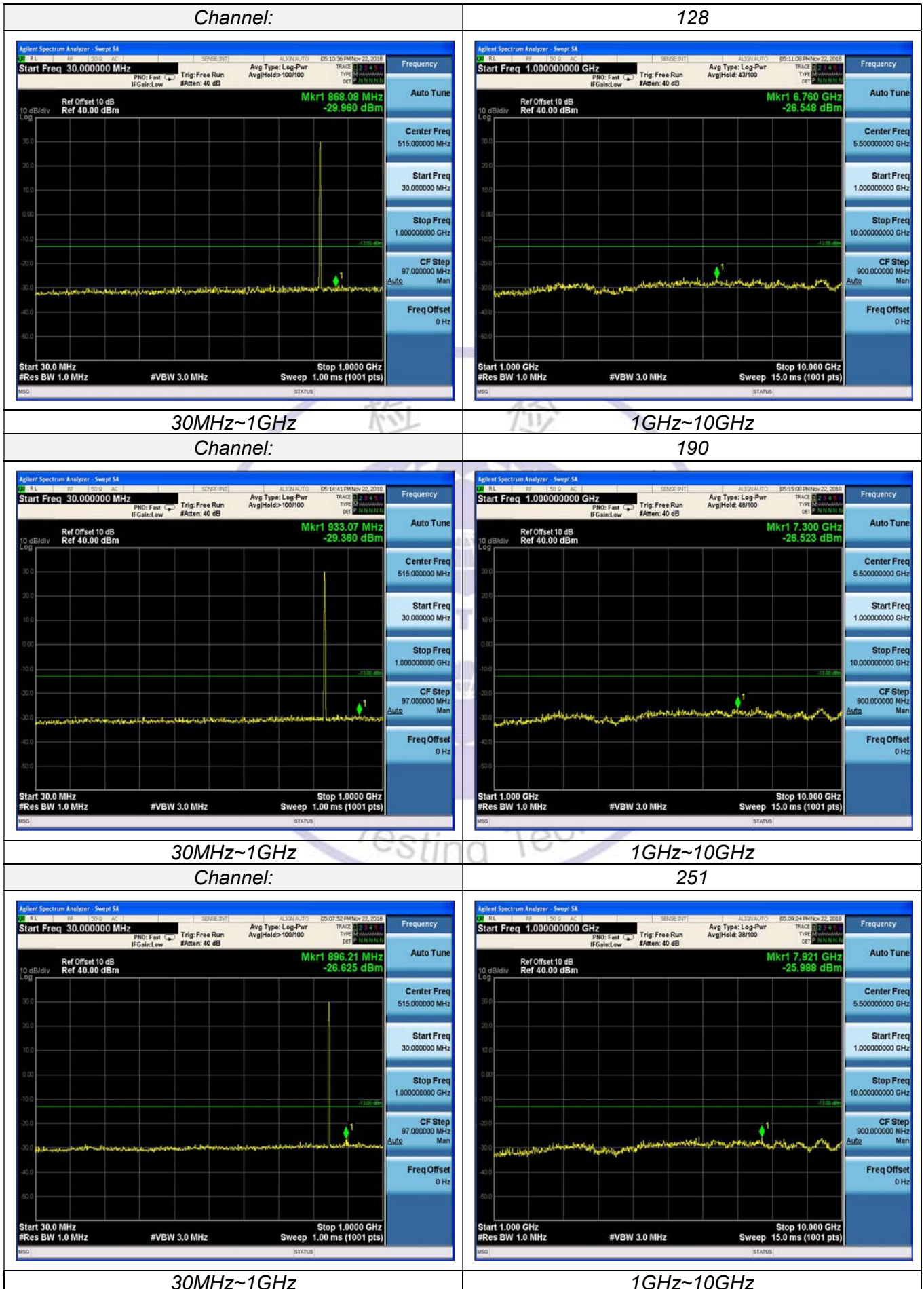

EGPRS850



GPRS1900

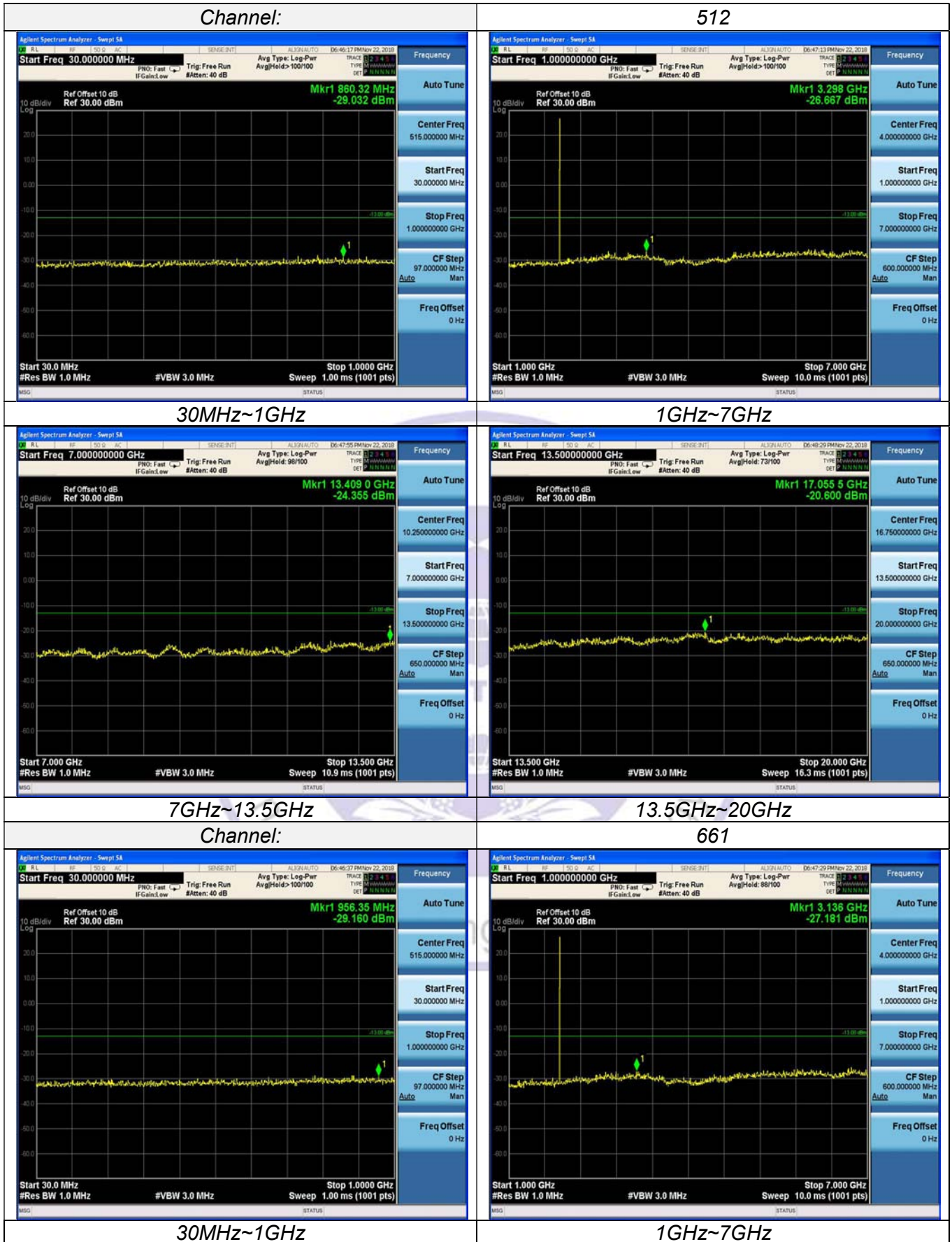



7GHz~13.5GHz
Channel:

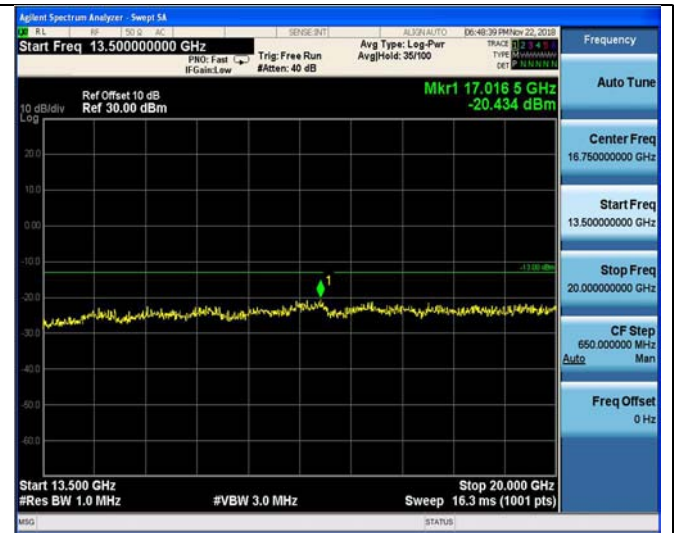

13.5GHz~20GHz
810

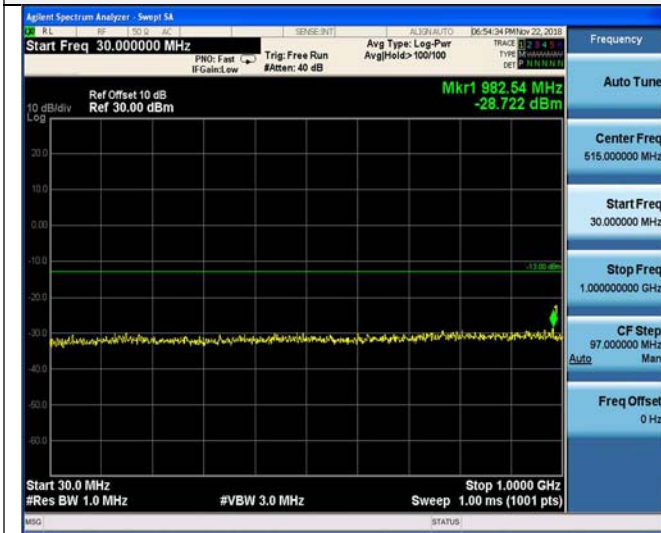

30MHz~1GHz

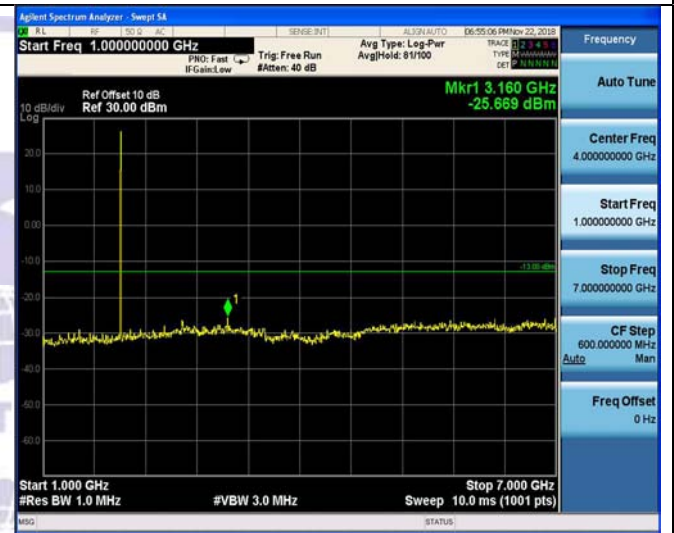

1GHz~7GHz

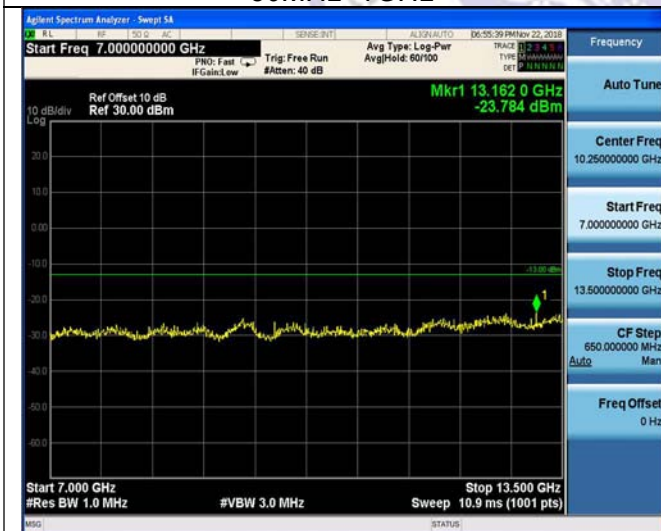

7GHz~13.5GHz



13.5GHz~20GHz

EGPRS1900





7GHz~13.5GHz
Channel:



13.5GHz~20GHz
810

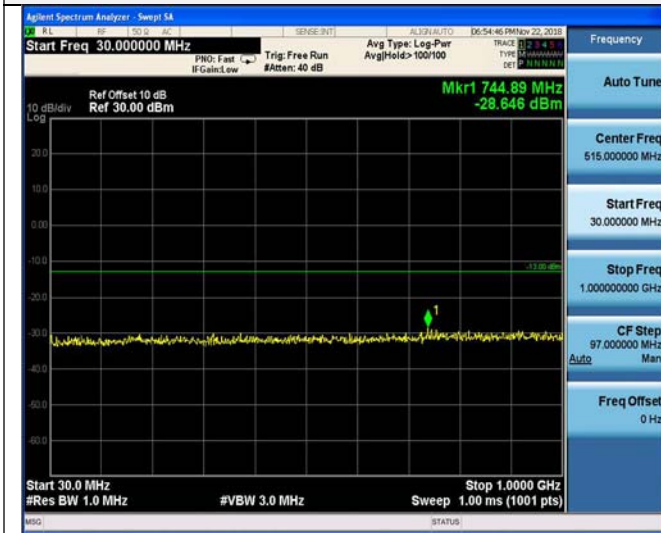

30MHz~1GHz



1GHz~7GHz



7GHz~13.5GHz

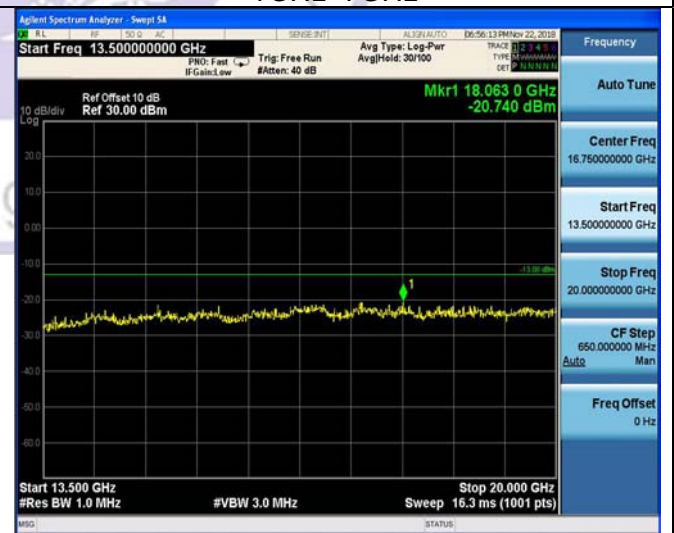

13.5GHz~20GHz

WCDMA Band II

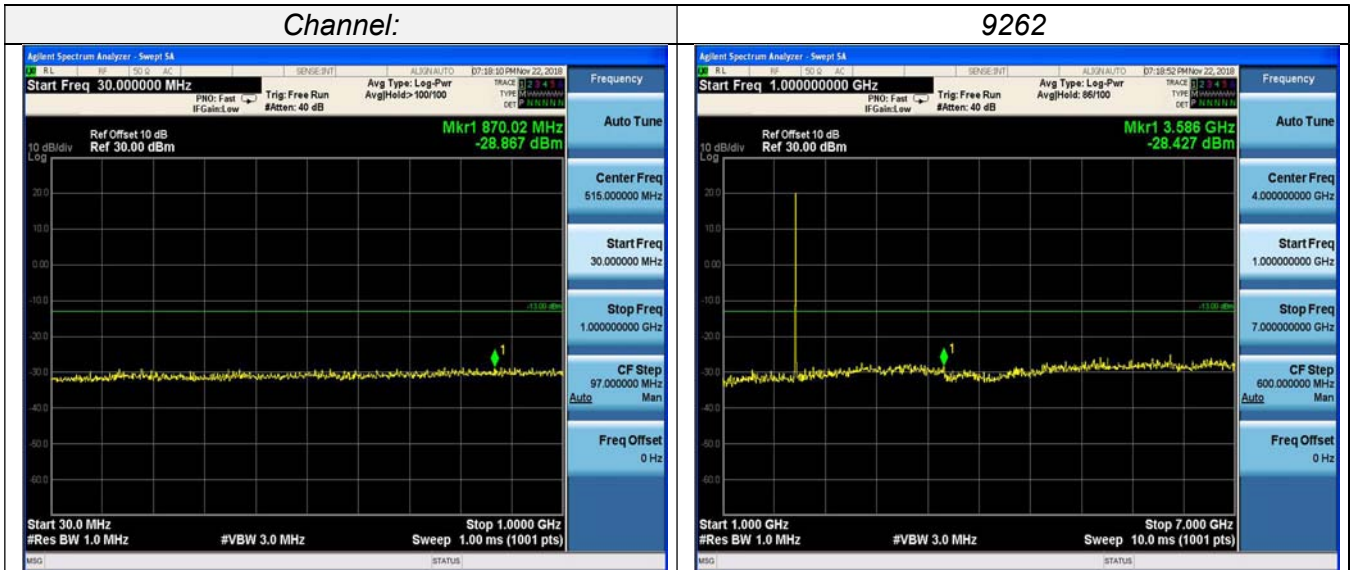

30MHz~1GHz

1GHz~7GHz



7GHz~13.6GHz

13.5GHz~20GHz

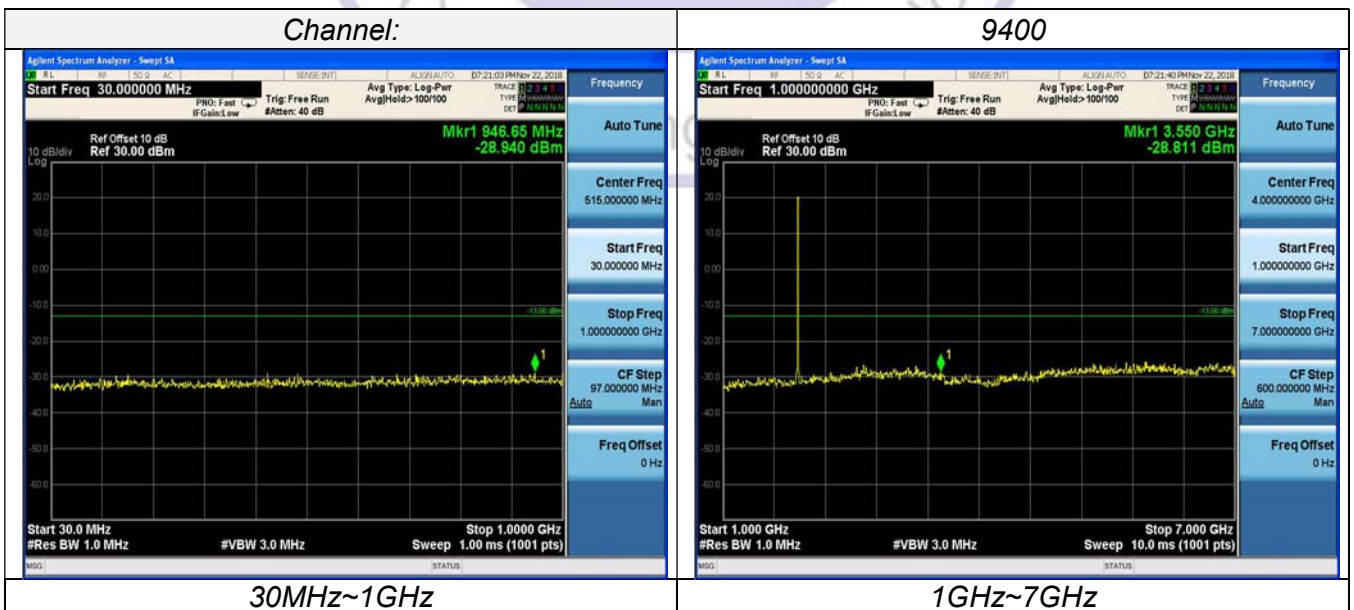

30MHz~1GHz

1GHz~7GHz



7GHz~13.6GHz
Channel:



13.5GHz~20GHz
9538

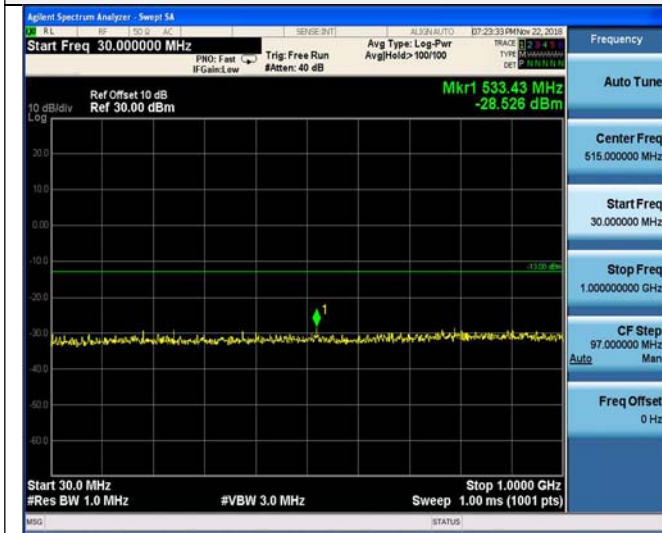

30MHz~1GHz



1GHz~7GHz



7GHz~13.6GHz



13.5GHz~20GHz

WCDMA Band V

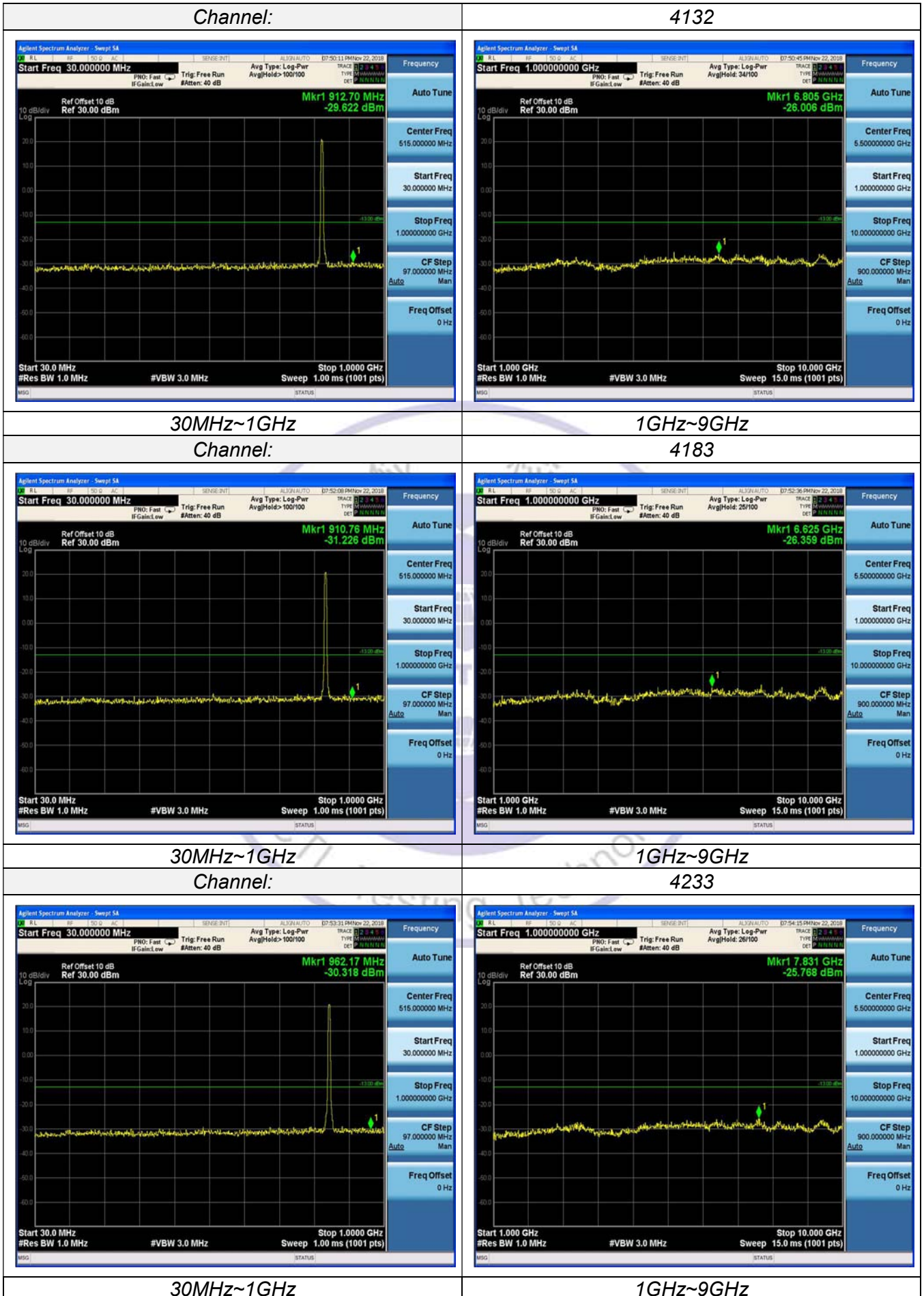

Radiated Measurement:**GPRS850**

Channel	Frequency (MHz)	P _{Mea} (dBm)	P _{cl} (dB)	Distance	G _a Antenna Gain(dB)	Peak EIRP (dBm)	Limit (dBm)	Margin (dB)	Polarization
128	1648.40	-30.75	3.00	3.00	9.58	-24.17	-13.00	11.17	H
	2472.60	-36.84	3.47	3.00	10.72	-29.59	-13.00	16.59	H
	1648.40	-29.25	3.00	3.00	9.68	-22.57	-13.00	9.57	V
	2472.60	-35.76	3.47	3.00	10.72	-28.51	-13.00	15.51	V
190	1673.20	-31.62	3.14	3.00	9.61	-25.15	-13.00	12.15	H
	2509.80	-36.47	3.59	3.00	10.77	-29.29	-13.00	16.29	H
	1673.20	-29.52	3.14	3.00	9.61	-23.05	-13.00	10.05	V
	2509.80	-35.45	3.59	3.00	10.77	-28.27	-13.00	15.27	V
251	1697.60	-30.01	3.26	3.00	9.77	-23.5	-13.00	10.50	H
	2546.40	-37.68	3.69	3.00	10.89	-30.48	-13.00	17.48	H
	1697.60	-29.38	3.26	3.00	9.77	-22.87	-13.00	9.87	V
	2546.40	-34.57	3.69	3.00	10.89	-27.37	-13.00	14.37	V

EGPRS850

Channel	Frequency (MHz)	P _{Mea} (dBm)	P _{cl} (dB)	Distance	G _a Antenna Gain(dB)	Peak EIRP (dBm)	Limit (dBm)	Margin (dB)	Polarization
128	1648.40	-29.95	3.00	3.00	9.58	-23.37	-13.00	10.37	H
	2472.60	-38.06	3.47	3.00	10.72	-30.81	-13.00	17.81	H
	1648.40	-31.19	3.00	3.00	9.68	-24.51	-13.00	11.51	V
	2472.60	-36.33	3.47	3.00	10.72	-29.08	-13.00	16.08	V
190	1673.20	-31.79	3.14	3.00	9.61	-25.32	-13.00	12.32	H
	2509.80	-37.06	3.59	3.00	10.77	-29.88	-13.00	16.88	H
	1673.20	-29.73	3.14	3.00	9.61	-23.26	-13.00	10.26	V
	2509.80	-34.46	3.59	3.00	10.77	-27.28	-13.00	14.28	V
251	1697.60	-31.10	3.26	3.00	9.77	-24.59	-13.00	11.59	H
	2546.40	-36.56	3.69	3.00	10.89	-29.36	-13.00	16.36	H
	1697.60	-30.05	3.26	3.00	9.77	-23.54	-13.00	10.54	V
	2546.40	-36.80	3.69	3.00	10.89	-29.60	-13.00	16.60	V

GPRS1900

Channel	Frequency (MHz)	P _{Mea} (dBm)	P _{cl} (dB)	Distance	G _a Antenna Gain(dB)	Peak EIRP (dBm)	Limit (dBm)	Margin (dB)	Polarization
512	3700.40	-34.28	4.25	3.00	12.34	-26.19	-13.00	13.19	H
	5550.60	-41.48	4.97	3.00	13.52	-32.93	-13.00	19.93	H
	3700.40	-33.96	4.25	3.00	12.34	-25.87	-13.00	12.87	V
	5550.60	-40.18	4.97	3.00	13.52	-31.63	-13.00	18.63	V
661	3760.00	-33.46	4.38	3.00	12.34	-25.50	-13.00	12.50	H
	5640.00	-40.81	5.01	3.00	13.58	-32.24	-13.00	19.24	H
	3760.00	-34.30	4.38	3.00	12.34	-26.34	-13.00	13.34	V
	5640.00	-40.49	5.01	3.00	13.58	-31.92	-13.00	18.92	V
810	3819.60	-32.39	4.49	3.00	12.45	-24.43	-13.00	11.43	H
	5729.40	-38.85	5.26	3.00	13.66	-30.45	-13.00	17.45	H
	3819.60	-33.27	4.49	3.00	12.45	-25.31	-13.00	12.31	V
	5729.40	-41.19	5.26	3.00	13.66	-32.79	-13.00	19.79	V

EGPRS1900

Channel	Frequency (MHz)	P _{Mea} (dBm)	P _{cl} (dB)	Distance	G _a Antenna Gain(dB)	Peak EIRP (dBm)	Limit (dBm)	Margin (dB)	Polarization
512	3700.40	-34.01	4.25	3.00	12.34	-25.92	-13.00	12.92	H
	5550.60	-38.85	4.97	3.00	13.52	-30.30	-13.00	17.30	H
	3700.40	-34.99	4.25	3.00	12.34	-26.90	-13.00	13.90	V
	5550.60	-38.56	4.97	3.00	13.52	-30.01	-13.00	17.01	V
661	3760.00	-35.06	4.38	3.00	12.34	-27.10	-13.00	14.10	H
	5640.00	-42.34	5.01	3.00	13.58	-33.77	-13.00	20.77	H
	3760.00	-34.05	4.38	3.00	12.34	-26.09	-13.00	13.09	V
	5640.00	-40.65	5.01	3.00	13.58	-32.08	-13.00	19.08	V
810	3819.60	-33.09	4.49	3.00	12.45	-25.13	-13.00	12.13	H
	5729.40	-38.69	5.26	3.00	13.66	-30.29	-13.00	17.29	H
	3819.60	-33.91	4.49	3.00	12.45	-25.95	-13.00	12.95	V
	5729.40	-37.48	5.26	3.00	13.66	-29.08	-13.00	16.08	V

WCDMA Band II

Channel	Frequency (MHz)	P _{Mea} (dBm)	P _{cl} (dB)	Distance	G _a Antenna Gain(dB)	Peak EIRP (dBm)	Limit (dBm)	Margin (dB)	Polarization
9262	3704.80	-38.28	4.27	3.00	12.34	-30.21	-13.00	17.21	H
	5557.20	-44.27	4.99	3.00	13.52	-35.74	-13.00	22.74	H
	3704.80	-37.42	4.27	3.00	12.34	-29.35	-13.00	16.35	V
	5557.20	-42.00	4.99	3.00	13.52	-33.47	-13.00	20.47	V
9400	3760.00	-36.24	4.38	3.00	12.34	-28.28	-13.00	15.28	H
	5640.00	-42.48	5.01	3.00	13.58	-33.91	-13.00	20.91	H
	3760.00	-38.84	4.38	3.00	12.34	-30.88	-13.00	17.88	V
	5640.00	-45.44	5.01	3.00	13.58	-36.87	-13.00	23.87	V
9538	3815.20	-37.36	4.47	3.00	12.45	-29.38	-13.00	16.38	H
	5722.80	-43.89	5.23	3.00	13.66	-35.46	-13.00	22.46	H
	3815.20	-39.19	4.47	3.00	12.45	-31.21	-13.00	18.21	V
	5722.80	-44.52	5.23	3.00	13.66	-36.09	-13.00	23.09	V

WCDMA Band V

Channel	Frequency (MHz)	P _{Mea} (dBm)	P _{cl} (dB)	Distance	G _a Antenna Gain(dB)	Peak EIRP (dBm)	Limit (dBm)	Margin (dB)	Polarization
9262	1652.80	-35.77	3.02	3.00	9.58	-29.21	-13.00	16.21	H
	2479.20	-39.83	3.51	3.00	10.72	-32.62	-13.00	19.62	H
	1652.80	-34.75	3.02	3.00	9.68	-28.09	-13.00	15.09	V
	2479.20	-40.31	3.51	3.00	10.72	-33.10	-13.00	20.10	V
9400	1673.20	-35.65	3.14	3.00	9.61	-29.18	-13.00	16.18	H
	2509.80	-39.98	3.59	3.00	10.77	-32.80	-13.00	19.80	H
	1673.20	-35.54	3.14	3.00	9.61	-29.07	-13.00	16.07	V
	2509.80	-42.10	3.59	3.00	10.77	-34.92	-13.00	21.92	V
9538	1693.20	-34.69	3.24	3.00	9.77	-28.16	-13.00	15.16	H
	2539.80	-38.58	3.65	3.00	10.89	-31.34	-13.00	18.34	H
	1693.20	-36.38	3.24	3.00	9.77	-29.85	-13.00	16.85	V
	2539.80	-40.72	3.65	3.00	10.89	-33.48	-13.00	20.48	V

Remark:

1. $EIRP = P_{Mea}(dBm) - P_{cl}(dB) + G_a(dBi)$
2. We were not recorded other points as values lower than limits.
3. $Margin = Limit - EIRP$

3.5 Frequency Stability under Temperature & Voltage Variations

LIMIT

Cellular Band: ± 2.5 ppm PCS Band: Within the authorized frequency block

TEST CONFIGURATION

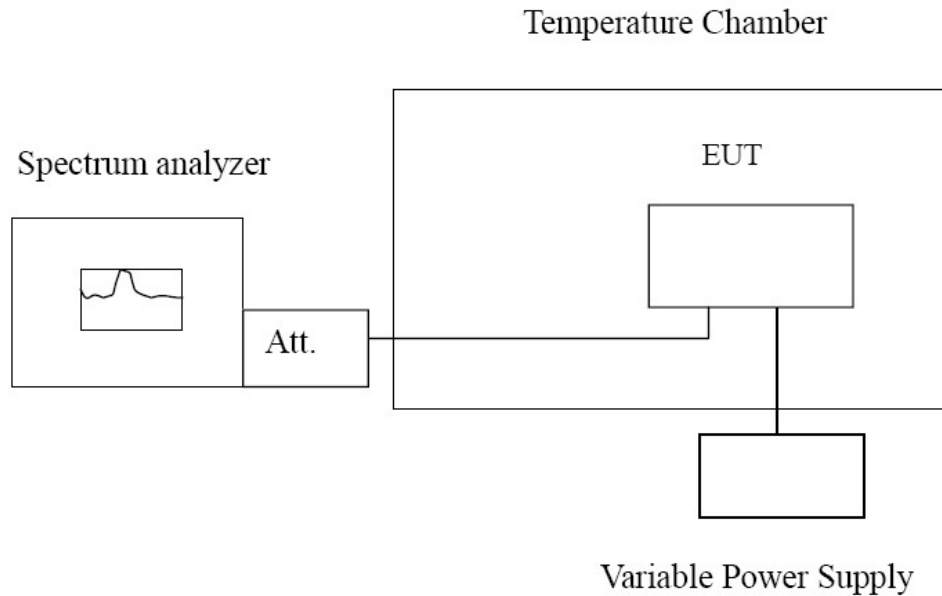

TEST PROCEDURE

The EUT was setup according to EIA/TIA 603C

Frequency Stability under Temperature Variations:

The equipment under test was connected to an external AC or DC power supply and input rated voltage. RF output was connected to a frequency counter or spectrum analyzer via feed through attenuators. The EUT was placed inside the temperature chamber. Set the spectrum analyzer RBW low enough to obtain the desired frequency resolution and measure EUT 20°C operating frequency as reference frequency. Turn EUT off and set the chamber temperature to -30°C. After the temperature stabilized for approximately 30 minutes recorded the frequency. Repeat step measure with 10°C increased per stage until the highest temperature of +50°C reached.

Frequency Stability under Voltage Variations:

Set chamber temperature to 20°C. Use a variable AC power supply / DC power source to power the EUT and set the voltage to rated voltage. Set the spectrum analyzer RBW low enough to obtain the desired frequency resolution and recorded the frequency.

Reduce the input voltage to specify extreme voltage variation ($\pm 15\%$) and endpoint, record the maximum frequency change.

TEST RESULTS

Reference Frequency: GPRS850 Middle channel=190 channel=836.6MHz					
Voltage (V)	Temperature (°C)	Frequency error		Limit (ppm)	Result
		Hz	ppm		
3.70	-30	103	0.123	2.5	Pass
	-20	113	0.135		
	-10	123	0.147		
	0	107	0.128		
	10	101	0.121		
	20	97	0.116		
	30	109	0.130		
	40	117	0.140		
4.26	25	105	0.126		
End point 3.15	25	122	0.146		

Reference Frequency: GPRS1900 Middle channel=661 channel=1880MHz					
Voltage (V)	Temperature (°C)	Frequency error		Limit (ppm)	Result
		Hz	ppm		
3.70	-30	128	0.068	Within the authorized frequency block	Pass
	-20	136	0.072		
	-10	126	0.067		
	0	139	0.074		
	10	132	0.070		
	20	121	0.064		
	30	137	0.073		
	40	141	0.075		
4.26	25	113	0.060		
End point 3.15	25	151	0.080		

Reference Frequency: WCDMA Band II Middle channel=9400 channel=1880MHz					
Voltage (V)	Temperature (°C)	Frequency error		Limit (ppm)	Result
		Hz	ppm		
3.70	-30	122	0.065	Within the authorized frequency block	Pass
	-20	116	0.062		
	-10	124	0.066		
	0	123	0.065		
	10	121	0.064		
	20	114	0.061		
	30	116	0.062		
	40	123	0.065		
4.26	25	109	0.058		
End point 3.15	25	140	0.074		

Reference Frequency: WCDMA Band V Middle channel=4182 channel=836.6MHz					
Voltage (V)	Temperature (°C)	Frequency error		Limit (ppm)	Result
		Hz	ppm		
3.70	-30	117	0.140	2.5	Pass
	-20	119	0.142		
	-10	116	0.139		
	0	113	0.135		
	10	105	0.126		
	20	104	0.124		
	30	112	0.134		
	40	115	0.137		
	50	123	0.147		
4.27	25	101	0.121		
End point 3.15	25	133	0.159		



4 Test Setup Photos of the EUT

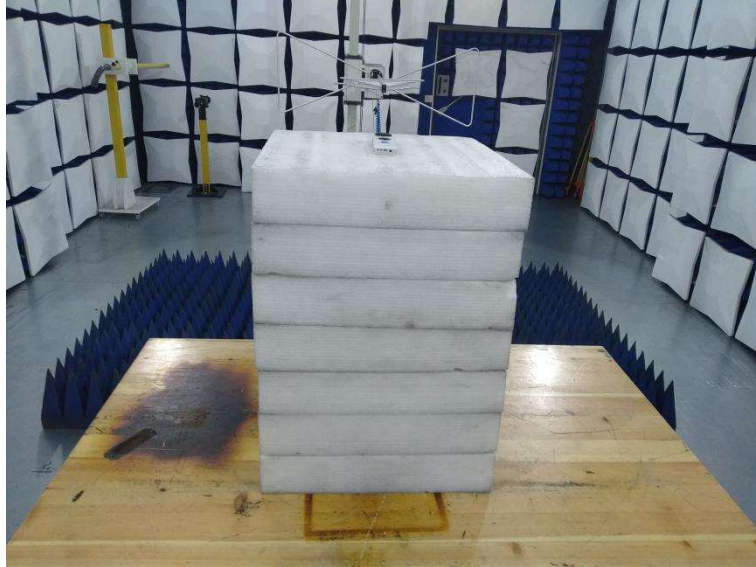

CTL Testing Techno

5 Photos of the EUT

Reference to the test report No. CTL1810196061-WF01

***** End of Report *****

