

Freq:462.5625 to 462.6875 MHz

MODEL: SKFung-12V6

Frequency:462.5625 to 462.6875 MHz

Modulation Mode:FM

ERP:≤0.5W , Channel Spacing = 25KHz

DraWinG:Nick Huang

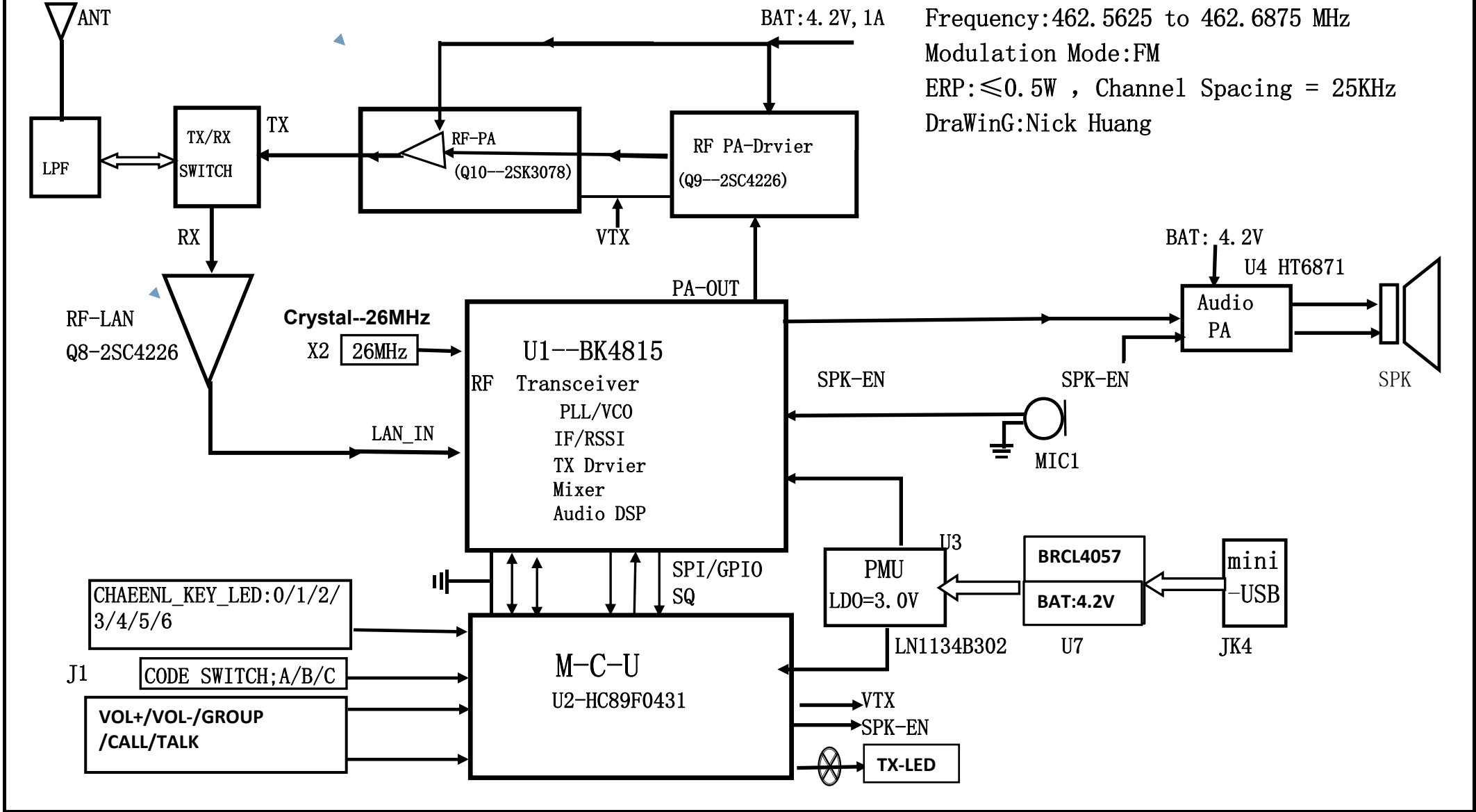

HOW IT WORKS:

1 Power management:

Connect the USB 5.0V for PA and PMU power management circuits.

PMU is made of LDO regulators for U1 BK4815 and U2 MCU.

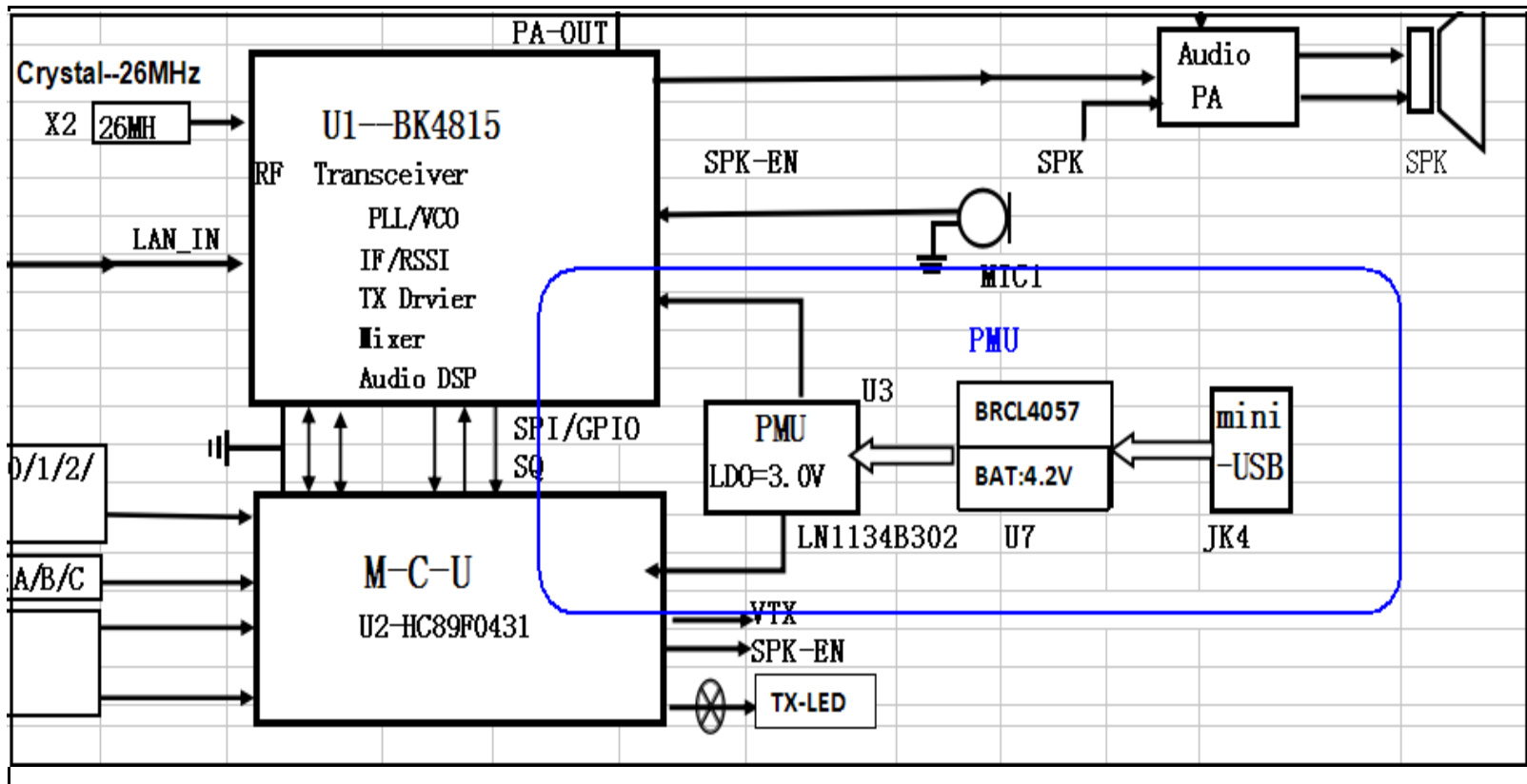

2 Start:

U1 and U2 on.

X2 26MHz crystal is on after U1 start-up. U1 initialization will complete within 200mS after MCU Boot. After the startup tone, the machine gets into normal operation. Power indicator LED1 light. Standby current $\leq 90\text{mA}$.

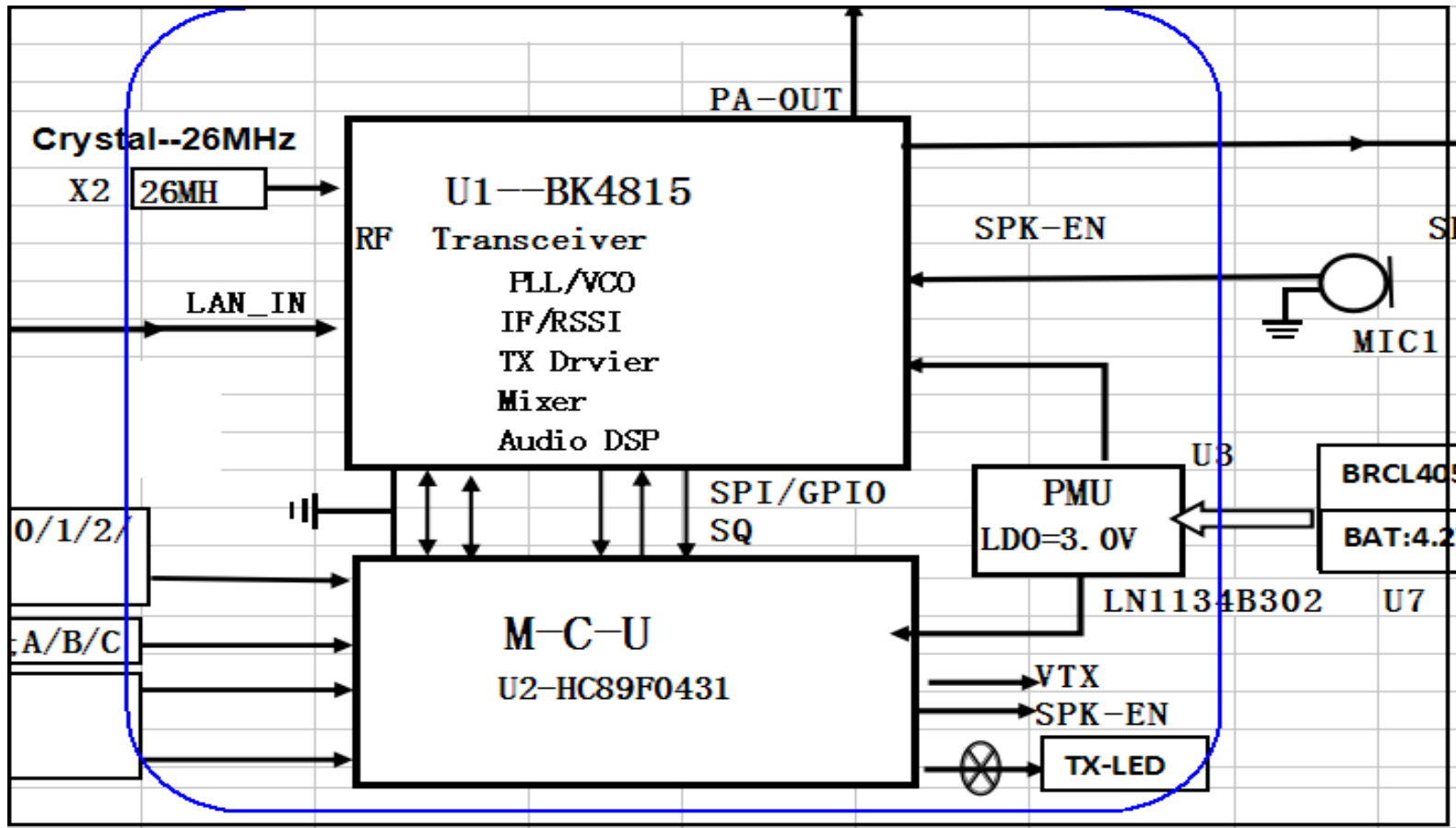

Frequency stabilizing circuit

Frequency stabilized circuit: the X2 26MHz temperature compensated crystal is provided by the U1 to make the emission frequency stable.

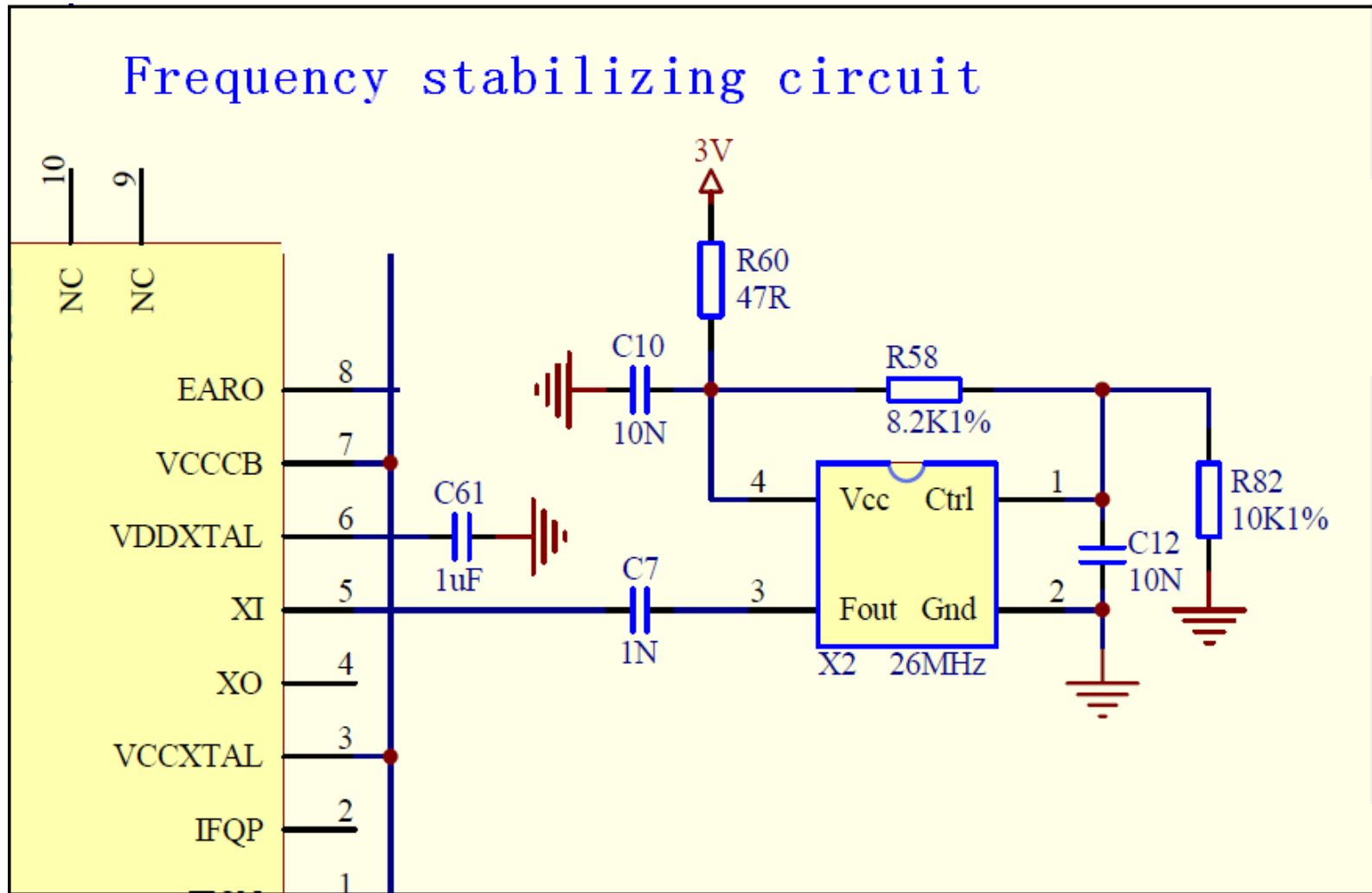

3 Transmit:

U1 is a fully integrated RF transceiver chip, with internal PLL / VCO / transmitter modulation. (Transmit modulation is fully provided by BK4815 U1 system)

When you press the PTT key, U1 receives emission control instructions from MCU.

Walkie-talkie is in the emission mode.

Transmit switch, RF PA and VTX signals are on. Release the TALK to stop transmitting.

Voice signal from MIC goes to the U1 to generate the modulated PA-OUT.

And then it goes through amplification stages Q9 and Q10 before suppressed by the low pass filter to get rid of RF harmonics.

Radio frequency 462.5625MHz; power $\leq 30\text{dBm}$.

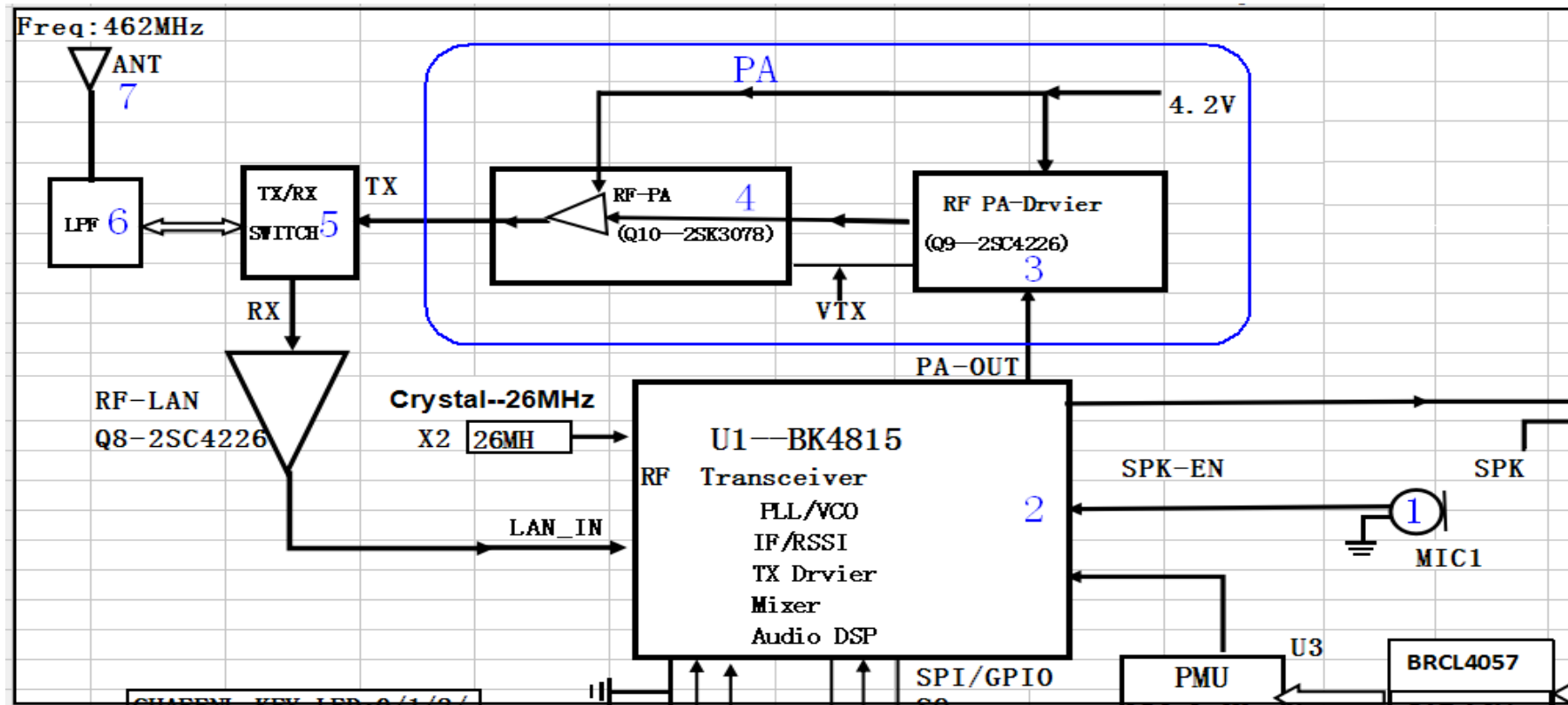

Stray radiation suppression circuit

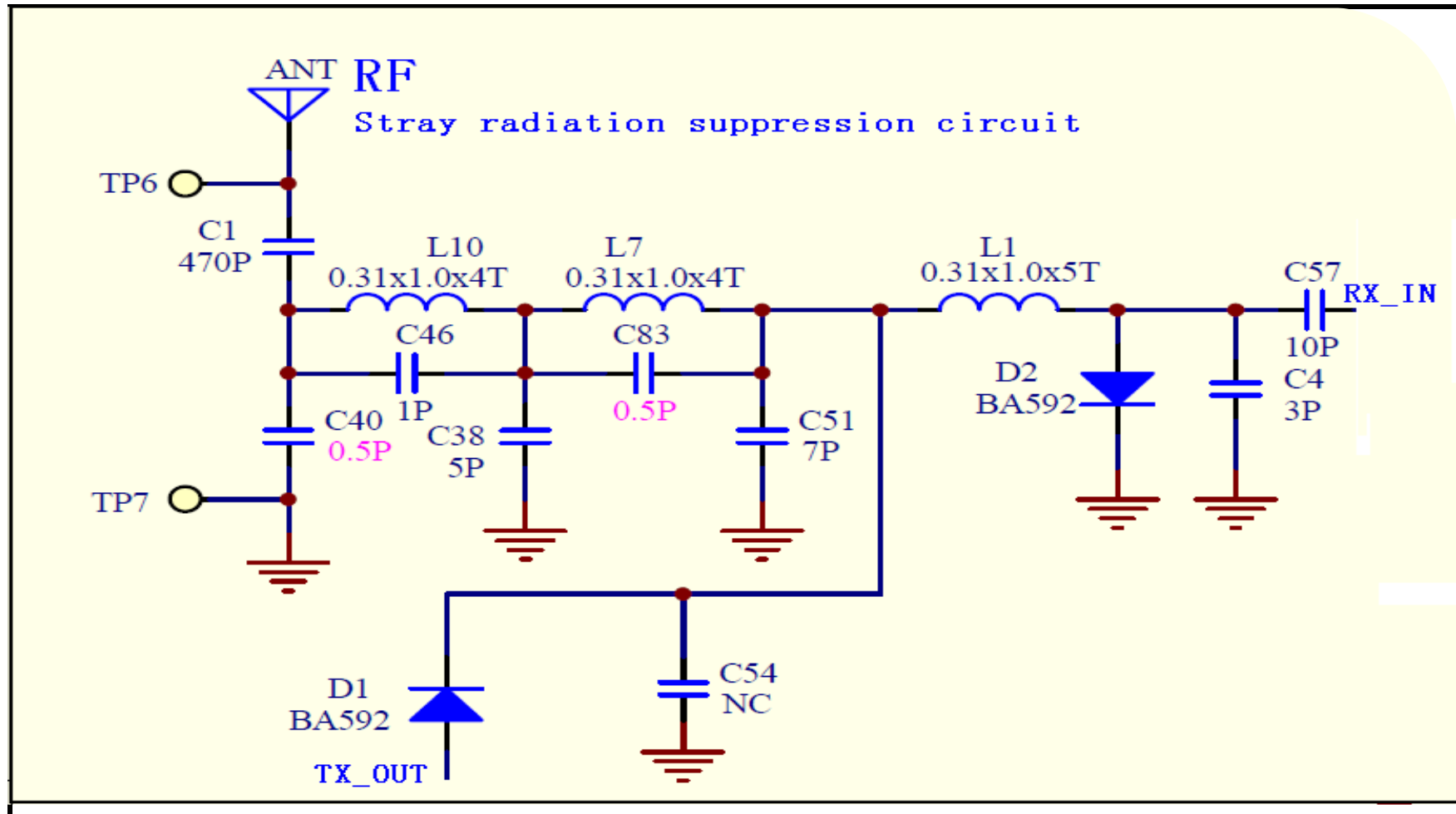

TX power Adjusting circuit

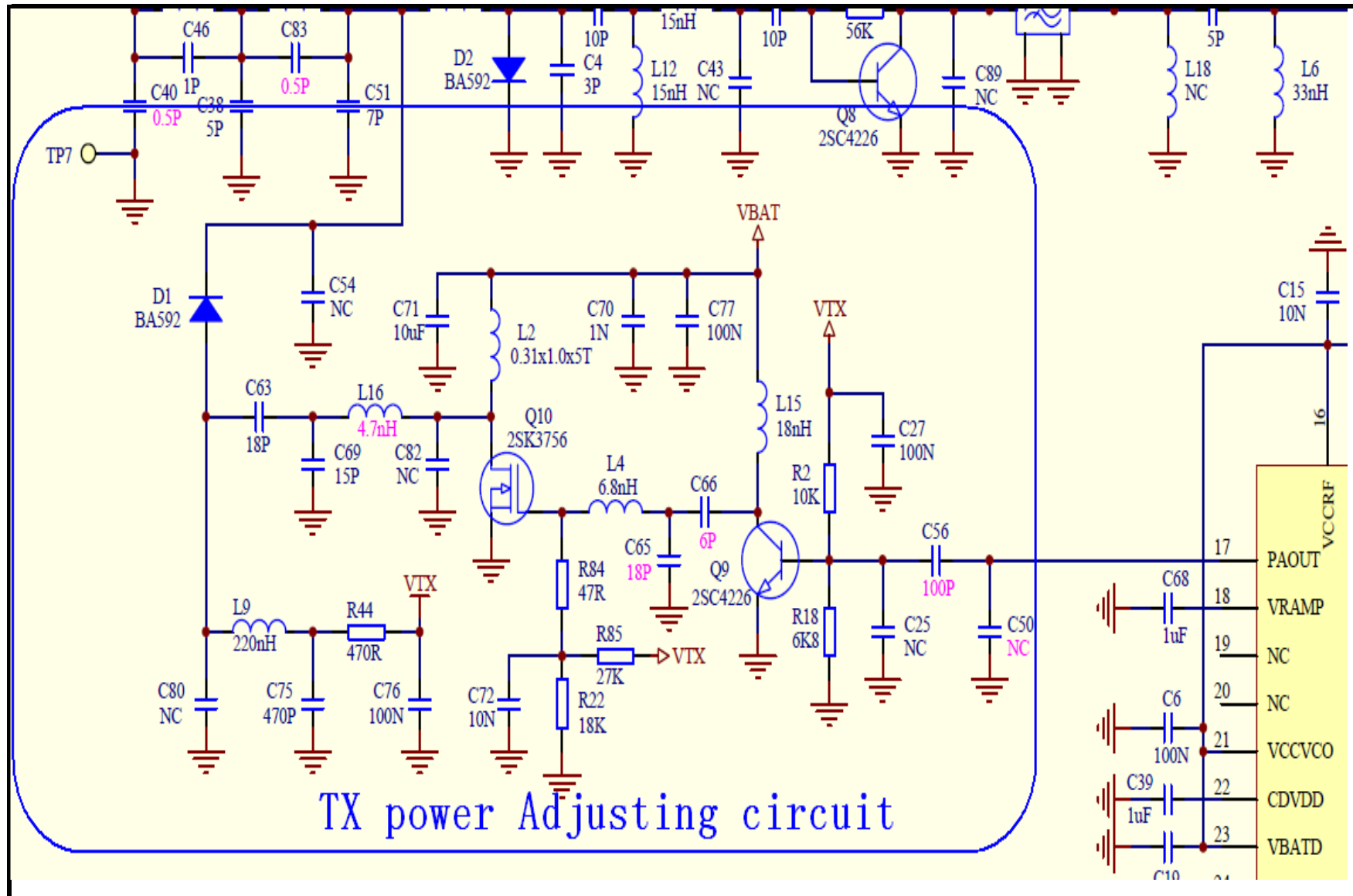

4 Receive:

U1 is a fully integrated transceiver chip with built-in PLL / VCO / IF / RSSI / AUDIO demodulation.

MCU monitors U1 modes. U1 feedbacks to MCU if identifying useful signals.

The useful signal will trigger the audio amplifier switch SPK-EN.

The interference signal is ignored and speaker is muted. (Receive current $\leq 300\text{mA}$)

The input signal from the antenna goes through the LPF bandpass filter, duplexer and the amplifier Q8 before eliminating spurious signals at F1 filter. MCU controls U1 to demodulate and detect RSSI and SQ signals to open the audio amplifier. Sound is from the speaker.

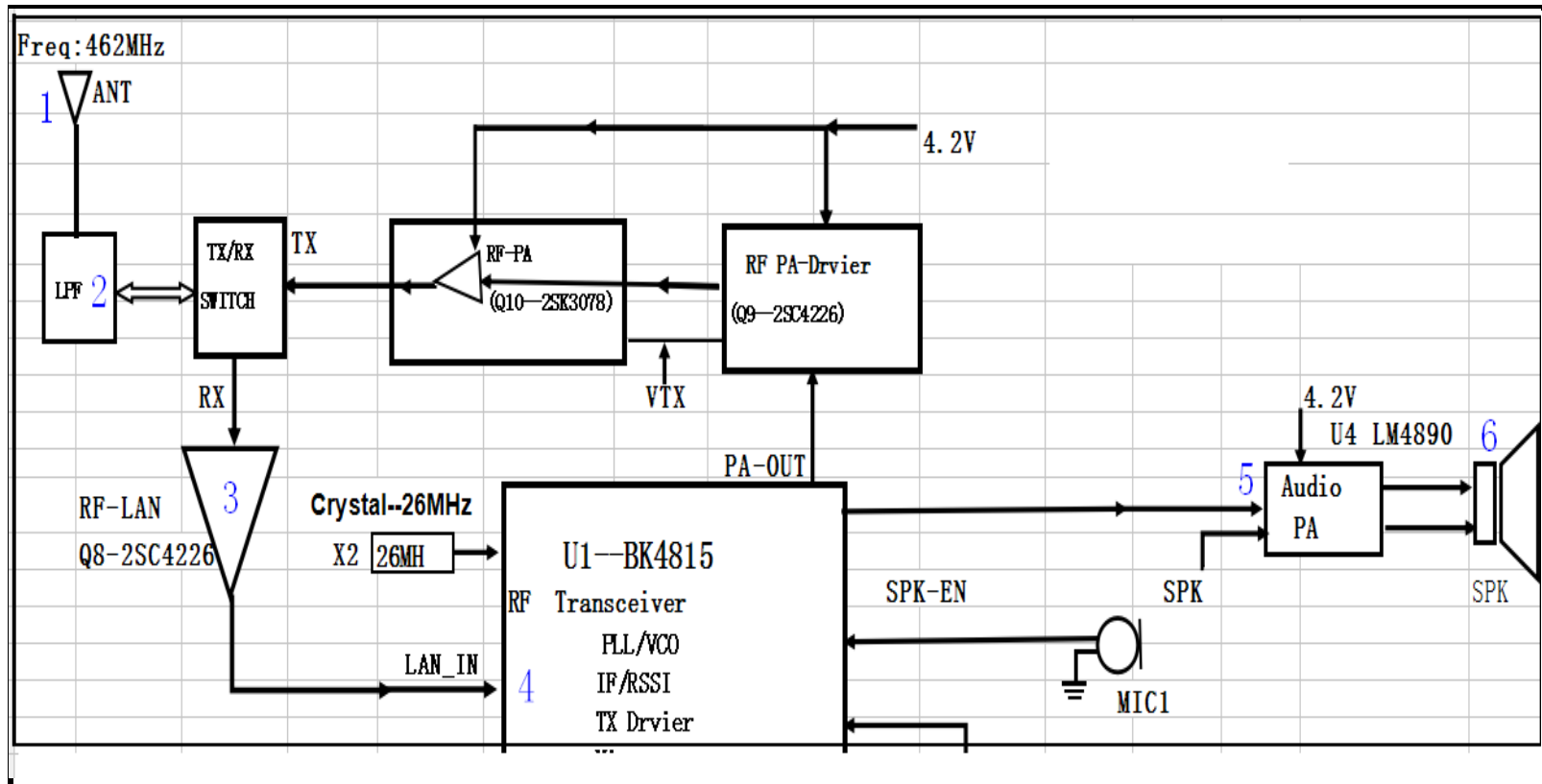

5 status light

1 in ALL CALL or TAK or TX_LED, CALL will be on the exit light is not bright.

2 in the channel selection will have the corresponding channel indicator 0/1/2/3/4/5/6 light.

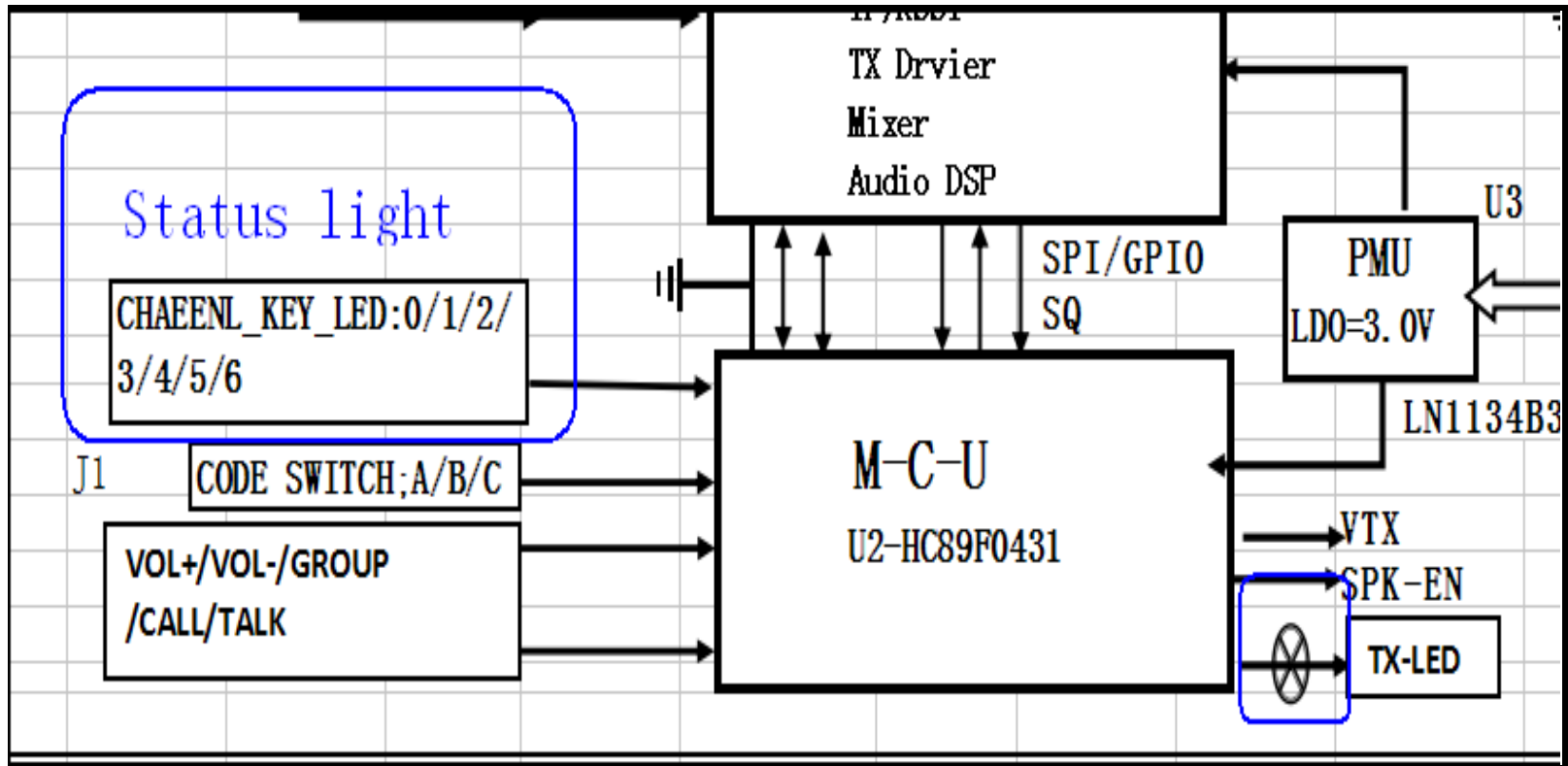

Antenna Type: Non-removable integral antenna

Antenna Gain: 1dBi

The antenna is designed such that the electric field of the emitted waves is vertically polarized when the unit is operated in the normal orientation.

---END---