

FCC CFR47 PART 22H, 24E, 27 CERTIFICATION TEST REPORT

FCC ID: 2AOWKGQ3086

Product: Mobile Phone
Trade Mark: ulefone
Model Number: GQ3086
Armor 9, Armor 9E, Armor 9S, Armor 9P,
Family Model: Armor 7X, Armor 7A, Armor 9 Pro, Armor 9
Lite
Report No.: STR200327001006E

Prepared for

Shenzhen Gotron Electronic CO.,LTD.
518, 5F, R&D building, Tsinghua Hi-Tech park, Nanshan district,
Shenzhen 518057 P.R.China

Prepared by

Shenzhen NTEK Testing Technology Co., Ltd.
1/F, Building E, Fenda Science Park, Sanwei Community, Xixiang Street
Bao'an District, Shenzhen 518126 P.R. China
Tel.: +86-755-6115 9388 Fax.: +86-755-6115 6599
Website: <http://www.ntek.org.cn>

TEST RESULT CERTIFICATION

Applicant's name : Shenzhen Gotron Electronic CO.,LTD.
Address : 518, 5F, R&D building, Tsinghua Hi-Tech park, Nanshan district, Shenzhen 518057 P.R.China
Manufacturer's Name : Shenzhen Gotron Electronic CO.,LTD.
Address : 518, 5F, R&D building, Tsinghua Hi-Tech park, Nanshan district, Shenzhen 518057 P.R.China
Product name : Mobile Phone
Model and/or type reference : GQ3086
Family Model: Armor 9, Armor 9E, Armor 9S, Armor 9P, Armor 7X, Armor 7A, Armor 9 Pro, Armor 9 Lite
Standards : FCC CFR 47 Part 22H, Part 24E, Part 27
Test procedure : ANSI C63.26:2015
ANSI/TIA-603-E-2016

This device described above has been tested by NTEK, and the test results show that the equipment under test (EUT) is in compliance with the FCC requirements. And it is applicable only to the tested sample identified in the report.

This report shall not be reproduced except in full, without the written approval of NTEK, this document may be altered or revised by NTEK, personal only, and shall be noted in the revision of the document.

Date of Test

Date (s) of performance of tests : 27 Mar. 2020 ~ 17 Jun, 2020
Date of Issue : 18 Jun, 2020

Test Result : Pass

Testing Engineer : [Signature]
(Cheng Jiawen)

Technical Manager : [Signature]
(Jason Chen)

Authorized Signatory : [Signature]
(Sam Chen)

TABLE OF CONTENTS

1. GENERAL INFORMATION	5
1.1 PRODUCT DESCRIPTION	5
1.2 RELATED SUBMITTAL(S) / GRANT (S)	7
1.3 TEST METHODOLOGY	7
1.4 TEST FACILITY	7
MEASUREMENT UNCERTAINTY	7
1.5 SPECIAL ACCESSORIES.....	7
1.6 WORST-CASE CONFIGURATION AND MODE.....	7
1.6 SUMMARY OF TEST RESULTS	8
2. SYSTEM TEST CONFIGURATION	10
2.1 EUT CONFIGURATION.....	10
2.2 EUT EXERCISE	10
2.3 CONFIGURATION OF EUT SYSTEM.....	10
2.4 TEST SETUP	11
3. TEST AND MEASUREMENT EQUIPMENT	12
4. OUTPUT POWER	14
4.1 OUTPUT POWER MEASUREMENT	14
6. BANDEDGE AND EMISSION MASK	17
7. OUT OF BAND EMISSIONS	18
7.1 MEASUREMENT METHOD	19
8. RADIATED MEASUREMENT	20
8.1. RADIATED POWER (ERP & EIRP).....	20
8.2 LTE BAND 2.....	21
8.3 LTE BAND 4.....	25
8.4 LTE BAND 5.....	29

8.5 LTE BAND 7	31
8.6 LTE BAND 17	33
8.7 LTE BAND 66	35
9. SPURIOUS RADIATION EMISSION	39
9.1 LTE BAND 2	41
9.2 LTE BAND 4	43
9.3 LTE BAND 5	45
9.4 LTE BAND 7	47
9.5 LTE BAND 17	49
9.6 LTE BAND 66	51
10. FREQUENCY STABILITY	52
10.1 LTE BAND 2	53
10.2 LTE BAND 4	55
10.3 LTE BAND 5	57
10.4 LTE BAND 7	59
10.5 LTE BAND 17	61
10.6 LTE BAND 66	63
11. PEAK-TO-AVERAGE RATIO	65
11.1 Description of the PAR Measurement	65
11.2 Measuring Instruments	65
11.3 Test Procedures	65
11.4 Test Setup	65

1. GENERAL INFORMATION

1.1 PRODUCT DESCRIPTION

A major technical description of EUT is described as following:

Product Designation:	Mobile Phone
Trade Mark	ulefone
Model Name	GQ3086
Family Model	Armor 9, Armor 9E, Armor 9S, Armor 9P, Armor 7X, Armor 7A, Armor 9 Pro, Armor 9 Lite
Model Difference	All models are the same circuit and RF module, except the model name.
FCC ID:	2AOWKGQ3086
Frequency Bands:	U.S. Bands: <input checked="" type="checkbox"/> LTE FDD Band 2, 4, 5, 7, 17, 66
Frequency Range:	LTE FDD Band 2 Uplink: 1850MHz-1910MHz, Downlink: 1930MHz-1990MHz; LTE FDD Band 4 Uplink: 1710MHz-1755MHz, Downlink: 2110MHz-2155MHz; LTE FDD Band 5 Uplink: 824MHz-849MHz, Downlink: 869MHz-894MHz; LTE-FDD Band 7 Uplink: 2500MHz-2570MHz, Downlink: 2620MHz-2690MHz; LTE FDD Band 17 Uplink: 704MHz-716MHz, Downlink: 734MHz-746MHz; LTE FDD Band 66 Uplink: 1710MHz-1780MHz, Downlink: 2110MHz-2200MHz;
Type of Modulation:	QPSK/16QAM
SIM Card	SIM 1 and SIM 2 is a chipset unit and tested as a single chipset. The SIM 1 is chosen for test.
Antenna:	PIFA Antenna
Antenna gain:	Band 2: 1.86dBi, Band 4: 0.5dBi, Band 5: 0.75dBi, Band 7: 1.32dBi, Band 17: 0.52dBi, Band 66: 1.23dBi
Power Supply:	DC 3.85V/6600mAh from Battery or DC 5V from USB Port.
Adapter:	Model: APS-KI018WU-G Input: 100-240V~50/60Hz 0.5A Max Output: 5V/7V/9V---2.0A, 12V---1.5A
Extreme Vol. Limits:	DC 3.4V to DC 4.4V (Nominal DC 3.85V) (Note 1)
HW Version	S95_V1.1
SW Version	Armor 9_TF1_EEA_V01

** Note1: The High Voltage 4.4V and Low Voltage 3.4V was declared by manufacturer, The EUT couldn't be operate normally with higher or lower voltage.

1.2 RELATED SUBMITTAL(S) / GRANT (S)

This submittal(s) (test report) is intended for **FCC ID: 2AOWKGGQ3086** filing to comply with the FCC Part 22H&24E &27.

1.3 TEST METHODOLOGY

The tests documented in this report were performed in accordance with ANSI/TIA-603-E-2016, FCC CFR 47 Part 2, Part 22, Part 24, Part 27, ANSI C63.26:2015.

1.4 TEST FACILITY

The test site used to collect the radiated data is located at:

ShenZhen NTEK Testing Technology Co., Ltd.

1/F, Building E, Fenda Science Park, Sanwei Community, Xixiang Street, Bao'an District, Shenzhen 518126 P.R.China.

The test site is constructed and calibrated to meet the FCC requirements in documents ANSI C63.26:2015& ANSI C63.4: 2014.

FCC Registration No.:463705

IC Registration No.:9270A-1,

CNAS Registration No.:L5516

MEASUREMENT UNCERTAINTY

The reported uncertainty of measurement, where expended uncertainty U is based on a standard uncertainty multiplied by a coverage factor of k=2, providing a level of confidence of approximately 95 %.

No.	Item	Uncertainty
1	Measuring Uncertainty for a Level of Confidence of 95% ($U = 2U_c(y)$)	2.5dB

1.5 SPECIAL ACCESSORIES

The battery and the charger, earphone supplied by the applicant were used as accessories and being tested with EUT intended for FCC grant together.

1.6 WORST-CASE CONFIGURATION AND MODE

The worst-case scenario for all measurements is based on the investigation results.

The device has LTE Bands of: Band 2, Band 4, Band 5, Band 7, Band 17, Band 66.

The RB Size was selected to measure for peak or average ERP and EIRP, which was based on the conducted power verification baseline data.

For the fundamental investigation of radiated emissions, the EUT is investigated for vertical and horizontal antenna orientations and X Y and Z orientations of the EUT alone. After the investigations the worst case was determined to be at X orientation for all LTE bands.

1.6 SUMMARY OF TEST RESULTS

FCC Part22, Subpart H/ FCC Part24, Subpart E, FCC Part27, Subpart L, KDB 971168 D01 Power Meas License Digital Systems v03			
FCC Rule	Test Item	Verdict	Remark
2.1046	Conducted Output Power	PASS	
22.913(d) 24.232(d) 27.50(d)(5) KDB 971168 D01 Clause 5.7	Peak-to-Average Ratio	PASS	
2.1049 22.917(b) 24.238(b) KDB 971168 D01 Clause 4.2	Occupied Bandwidth	PASS	
2.1051 22.917(a) 24.238(a) 27.53(c), (g), (h) KDB 971168 D01 Clause 6	Band Edge	PASS	
22.913(a)(2) 27.50(b)(10), (c)(10) KDB 971168 D01 Clause 5.6	Effective Radiated Power	PASS	
24.232(c) 27.50(h)(2), (d)(4) KDB 971168 D01 Clause 5.6	Equivalent Isotropic Radiated Power	PASS	
2.1053 22.917(a) 24.238(a) 27.53(c)(g)(h)(m) KDB 971168 D01 Clause 7	Field Strength of Spurious Radiation	PASS	
2.1055 22.355 24.235 27.54 KDB 971168 D01 Clause 9	Frequency Stability for Temperature & Voltage	PASS	

2.1051 22.917(a) 24.238(a) 27.53(c)(g)(h)(m) KDB 971168 D01 Clause 6	Conducted Emission	PASS	
--	--------------------	------	--

Remark:

1. "N/A" denotes test is not applicable in this Test Report.
2. All test items were verified and recorded according to the standards and without any deviation during the test.
3. No modifications are made to the EUT during all test items.

2. SYSTEM TEST CONFIGURATION

2.1 EUT CONFIGURATION

The EUT configuration for testing is installed on RF field strength measurement to meet the Commission's requirement and operating in a manner which intends to maximize its emission characteristics in a continuous normal application.

2.2 EUT EXERCISE

The Transmitter was operated in the maximum output power mode through Communication Tester. The TX frequency was fixed which was for the purpose of the measurements.

2.3 CONFIGURATION OF EUT SYSTEM

Table 2-1 Equipment Used in EUT System

Item	Equipment	Model No.	ID or Specification	Note
1	Mobile Phone	GQ3086	FCC ID: 2AOWKGGQ3086	EUT

*Note: All the accessories have been used during the test.
the following "EUT" in setup diagram means EUT system.*

2.4 TEST SETUP

For Radiated Test Cases

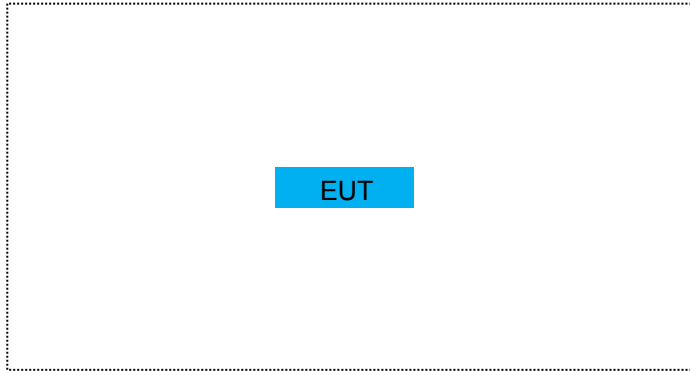

For Conducted Output Power

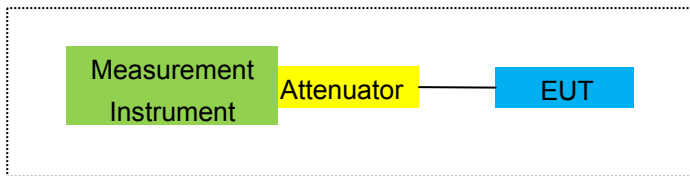

For Peak-to Average Ratio, Occupied Bandwidth, Conducted Band edge and Conducted Spurious Emission

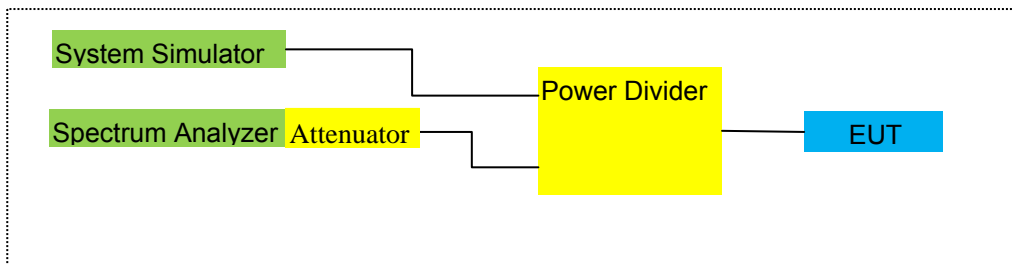

For Frequency Stability

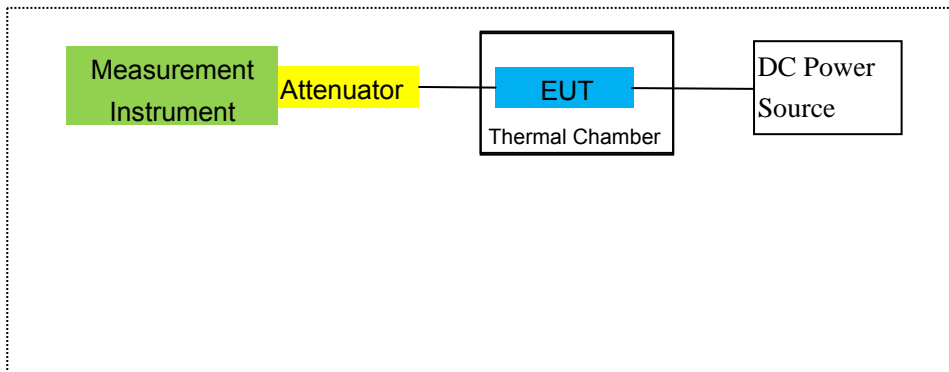

Note: EUT built-in battery-powered, the battery is fully-charged.

3. TEST AND MEASUREMENT EQUIPMENT

The following test and measurement equipment was utilized for the tests documented in this report:

Item	Kind of Equipment	Manufacturer	Type No.	Serial No.	Last calibration	Calibrated until	Calibration period
1	MXA Signal Analyzer	Agilent	N9020A	MY49100060	2019.08.28	2020.08.27	1 year
2	Test Receiver	R&S	ESPI	101318	2020.05.11	2021.05.10	1 year
3	Bilog Antenna	TESEQ	CBL6111D	31216	2020.04.11	2021.04.10	1 year
4	50Ω Coaxial Switch	Anritsu	MP59B	6200983705	2020.05.11	2023.05.10	1 year
5	Horn Antenna	EM	EM-AH-10180	2011071402	2020.04.11	2021.04.10	1 year
6	Horn Ant	Schwarzbeck	BBHA 9170	9170-181	2019.12.10	2020.12.09	1 year
7	Amplifier	EM	EM-30180	060538	2019.08.06	2020.08.05	1 year
8	Loop Antenna	ARA	PLA-1030/B	1029	2020.05.11	2021.05.10	1 year
9	Power Meter	R&S	NRVS	100696	2019.08.06	2020.08.05	1 year
10	Power Sensor	R&S	URV5-Z4	0395.1619.05	2020.05.11	2021.05.10	1 year
11	Test Cable	N/A	R-01	N/A	2019.08.06	2022.08.05	3 year
12	Test Cable	N/A	R-02	N/A	2019.08.06	2020.08.05	3 year
13	Test Cable	N/A	R-03	N/A	2019.06.28	2022.06.27	3 year
14	Test Receiver	R&S	ESCI	101160	2020.05.11	2021.05.10	1 year
15	LISN	R&S	ENV216	101313	2020.05.11	2021.05.10	1 year
16	LISN	EMCO	3816/2	00042990	2020.05.11	2021.05.10	1 year
17	50Ω Coaxial Switch	Anritsu	MP59B	6200264417	2019.05.13 2020.05.11	2020.05.12 2021.05.10	1 year
18	Passive Voltage Probe	R&S	ESH2-Z3	100196	2020.04.11	2021.04.10	3 year
19	Test Cable	N/A	C01	N/A	2020.05.11	2023.05.10	3 year
20	Test Cable	N/A	C02	N/A	2020.05.11	2023.05.10	3 year
21	Test Cable	N/A	C03	N/A	2020.05.11	2021.05.10	1 year
22	Attenuator	MCE	24-10-34	BN9258	2020.05.11	2021.05.10	1 year
23	Spectrum Analyzer	agilent	e4440a	us44300399	2020.05.11	2021.05.10	1 year
24	test receiver	R&S	ESCI	a0304218	2020.05.11	2021.05.10	1 year
25	Communication Tester	R&S	CMU200	A0304247	2019.08.06	2020.08.05	1 year
26	Thermal Chamber	Ten Billion	TTC-B3C	TBN-960502	2020.05.11	2021.05.10	1 year

27	DC Power Source	N/A	PS-6005D	2017040292 3	2017.06.06	2020.06.05	3 year
28	PSG Analog Signal Generator	Agilent	E8257D	MY51110112	2019.08.06	2020.08.05	1 year
29	Communication Tester	R&S	CMW500	148500	2020.05.11	2021.05.10	1 year

Note: Each piece of equipment is scheduled for calibration once a year except the Test Cable& DC Power Source which is scheduled for calibration every 3 years.

4. OUTPUT POWER

4.1 OUTPUT POWER MEASUREMENT

LTE Measurement Procedure:

All LTE bands conducted power peak and average are obtained from the CMW500 telecommunication test set. The following tests were conducted according to the test requirements outlined in section 6.2 of the 3GPP TS36.101 specification.

UE Power Class: 3 (23 +/- 2dBm). The allowed Maximum Power Reduction (MPR) for the maximum output power due to higher order modulation and transmit bandwidth configuration (resource blocks) is specified in Table 6.2.3-1 of the 3GPP TS36.101.

Table 6.2.3-1: Maximum Power Reduction (MPR) for Power Class 3

Modulation	Channel bandwidth / Transmission bandwidth (RB)						MPR (dB)
	1.4 MHz	3.0 MHz	5 MHz	10 MHz	15 MHz	20 MHz	
QPSK	> 5	> 4	> 8	> 12	> 16	> 18	≤ 1
16 QAM	≤ 5	≤ 4	≤ 8	≤ 12	≤ 16	≤ 18	≤ 1
16 QAM	> 5	> 4	> 8	> 12	> 16	> 18	≤ 2

The allowed A-MPR values specified below in Table 6.2.4.-1 of 3GPP TS36.101 are in addition to the allowed MPR requirements. All the measurements below were performed with A-MPR disabled, by using Network Signaling Value of "NS_01".3

Table 6.2.4-1: Additional Maximum Power Reduction (A-MPR)

Network Signalling value	Requirements (sub-clause)	E-UTRA Band	Channel bandwidth (MHz)	Resources Blocks (N_{RB})	A-MPR (dB)
NS_01	6.6.2.1.1	Table 5.5-1	1.4, 3, 5, 10, 15, 20	Table 5.6-1	NA
NS_03	6.6.2.2.1	2, 4, 10, 23, 25, 35, 36	3	>5	≤ 1
			5	>6	≤ 1
			10	>6	≤ 1
			15	>8	≤ 1
			20	>10	≤ 1
NS_04	6.6.2.2.2	41	5	>6	≤ 1
			10, 15, 20	See Table 6.2.4-4	
NS_05	6.6.3.3.1	1	10, 15, 20	≥ 50	≤ 1
NS_06	6.6.2.2.3	12, 13, 14, 17	1.4, 3, 5, 10	Table 5.6-1	n/a
NS_07	6.6.2.2.3	13	10	Table 6.2.4-2	Table 6.2.4-2
	6.6.3.3.2				
NS_08	6.6.3.3.3	19	10, 15	> 44	≤ 3
NS_09	6.6.3.3.4	21	10, 15	> 40	≤ 1
				> 55	≤ 2
NS_10		20	15, 20	Table 6.2.4-3	Table 6.2.4-3
NS_11	6.6.2.2.1	23 ¹	1.4, 3, 5, 10	Table 6.2.4-5	Table 6.2.4-5
..					
NS_32	-	-	-	-	-

Note 1: Applies to the lower block of Band 23, i.e. a carrier placed in the 2000-2010 MHz region.

Test data reference attachment.

5. OCCUPIED BANDWIDTH

RULE PART(S)

FCC: §2.1049

LIMITS

For reporting purposes only

TEST PROCEDURE

The transmitter output was connected to a calibrated coaxial cable and coupler, the other end of which was connected to a spectrum analyzer. The occupied bandwidth was measured with the spectrum analyzer at the low, middle and high channel in each band. The -26dB bandwidth was also measured and recorded.

MODES TESTED

- LTE Band 2
- LTE Band 4
- LTE Band 5
- LTE Band 7
- LTE Band 17
- LTE Band 66

RESULTS

PASS

Test data reference attachment.

6. BANDEDGE AND EMISSION MASK

RULE PART(S)

FCC: §2.1051, §22.917(a), §24.238(a), §27.53(c)(g)(h)(m)

FCC: §2.1046, §22.913, §24.232

LIMITS

The minimum permissible attenuation level of any spurious emission is $43 + \log_{10}(P[\text{Watts}])$, where P is the transmitter power in Watts.

The minimum permissible attenuation level for Band 7 is as following.

Per 27.53(g) for operations in the 698-746 MHz band, in the 100 kHz bands immediately outside and adjacent to the frequency block a resolution bandwidth of at least 30 kHz may be employed to demonstrate compliance with the out-of-band emissions limit.

Per 27.53(c.5) for operations in the 776-788 MHz band, in the 100 kHz bands immediately outside and adjacent to the frequency block a resolution bandwidth of at least 30 kHz may be employed to demonstrate compliance with the out-of-band emissions limit.

For all plots showing emissions in the 763 – 775MHz and 793 – 805MHz band, the FCC limit per 27.53(c.4) is $65 + 10\log_{10}(P) = -35\text{dBm}$ in a 6.25kHz bandwidth.

Per 27.53(m) for operations in the BRS/EBS bands, the attenuation factor shall be not less than $40 + 10 \log (P)$ dB on all frequencies between the channel edge and 5 megahertz from the channel edge, $43 + 10 \log (P)$ dB on all frequencies between 5 megahertz and X megahertz from the channel edge, and $55 + 10 \log (P)$ dB on all frequencies more than X megahertz from the channel edge, where X is the greater of 6 megahertz or the actual emission bandwidth.

TEST PROCEDURE

The transmitter output was connected to a CMW500 Test Set and configured to operate at maximum power. The band edge emissions were measured at the required operating frequencies in each band on the Spectrum Analyzer.

For each band edge measurement:

Set the spectrum analyzer span to include the block edge frequency

Set a marker to point the corresponding band edge frequency in each test case.

Set display line

Set resolution bandwidth to at least 1% of emission bandwidth.

MODES TESTED

LTE Band 2/4/5/7/17/66

RESULTS

Test data reference attachment.

7. OUT OF BAND EMISSIONS

RULE PART(S)

FCC: §2.1051, §22.917(a), §24.238(a), §27.53(c)(g)(h)(m)

LIMITS

The minimum permissible attenuation level of any spurious emission is $43 + \log_{10}(P[\text{Watts}])$, where P is the transmitter power in Watts.

The minimum permissible attenuation level for Band 7 is as following.

Per 27.53(g) for operations in the 698-746 MHz band, in the 100 kHz bands immediately outside and adjacent to the frequency block a resolution bandwidth of at least 30 kHz may be employed to demonstrate compliance with the out-of-band emissions limit.

Per 27.53(c.5) for operations in the 776-788 MHz band, in the 100 kHz bands immediately outside and adjacent to the frequency block a resolution bandwidth of at least 30 kHz may be employed to demonstrate compliance with the out-of-band emissions limit.

For all plots showing emissions in the 763 – 775MHz and 793 – 805MHz band, the FCC limit per 27.53(c.4) is $65 + 10\log_{10}(P) = -35\text{dBm}$ in a 6.25kHz bandwidth.

Per 27.53(m) for operations in the BRS/EBS bands, the attenuation factor shall be not less than $40 + 10 \log (P)$ dB on all frequencies between the channel edge and 5 megahertz from the channel edge, $43 + 10 \log (P)$ dB on all frequencies between 5 megahertz and X megahertz from the channel edge, and $55 + 10 \log (P)$ dB on all frequencies more than X megahertz from the channel edge, where X is the greater of 6 megahertz or the actual emission bandwidth.

TEST PROCEDURE

The RF output of the transmitter was connected to a spectrum analyzer through a calibrated coaxial cable. Sufficient scans were taken to show the out-of-band Emissions, if any, up to 10th harmonic. Multiple sweeps were recorded in maximum hold mode using a peak detector to ensure that the worst-case emissions were caught.

For each out of band emissions measurement:

Set display line

Set RBW & VBW to 100 kHz for the measurement below 1 GHz, and 1 MHz for the measurement above 1 GHz.

MODES TESTED

LTE Band 2

LTE Band 4

LTE Band 5

LTE Band 7

LTE Band 17

LTE Band 66

7.1 MEASUREMENT METHOD

The test set up and general procedure is similar to conducted peak output power test. Only different for setting the measurement configuration of the measuring instrument of Spectrum Analyzer.

Test data reference attachment.

Note: Both QPSK and 16QAM has been tested, the worst case is QPSK mode, the report just reported the worst case.

8. RADIATED MEASUREMENT

8.1. RADIATED POWER (ERP & EIRP)

RULE PART(S)

FCC: §2.1046, §22.913(a)(2), §24.232(c) and §27.50 (h)(2), (b)(10), (c)(10), (d)(4)

LIMITS:

22.913(a) (2)- The ERP of mobile transmitters and auxiliary test transmitters must not exceed 7 Watts.
24.232 (c) Mobile and portable stations are limited to 2 watts EIRP.
27.50 (c) (10) the following power and antenna height requirements apply to stations transmitting in the 698–746 MHz band, the portable stations (hand-held devices) are limited to 3 watts ERP.
27.50 (b)(10) Portable stations (hand-held devices) transmitting in the 746–757 MHz, 758–763 MHz, 776–793 MHz, and 805–806 MHz bands are limited to 3 watts ERP.
27.50 (d)(4) The following power and antenna height requirements apply to stations transmitting in the 1710–1755 MHz and 2110–2155 MHz bands: Fixed, mobile, and portable (hand-held) stations operating in the 1710–1755 MHz band are limited to 1 watt EIRP.
27.50 (h)(2) Mobile and other user stations in the 2500–2570 MHz and 2620–2690 MHz bands. Mobile stations are limited to 2.0 watts EIRP. All user stations are limited to 2.0 watts transmitter output power.

TEST PROCEDURE

ANSI/TIA-603-E Clause 2.2.17

KDB 971168 v02r01 RF power output using broadband peak and average power meter method.

KDB 971168 D01 Power Meas License Digital Systems v02r01, "Measurement Guidance for Certification of Licensed Digital Transmitters"

MODES TESTED

LTE Band 2
LTE Band 4
LTE Band 5
LTE Band 7
LTE Band 17
LTE Band 66

RESULTS

Pass

8.2 LTE BAND 2

Radiated Power (EIRP) for Band 2									
Mode	RB/RB SIZE	Frequency	Result						Conclusion
			SG Level (dBm)	Cable Loss (dBm)	Antenna Gain (dB)	Max. EIRP Average (dBm)	Max. EIRP Average (mW)	Polarization Of Max. ERP	
1.4MHz Band QPSK	1/#Mid	1850.7	0.66	3.76	28.24	25.14	326.588	Horizontal	Pass
		1880	0.85	3.91	28.22	25.16	328.095	Horizontal	Pass
		1909.3	0.94	3.93	28.20	25.21	331.894	Horizontal	Pass
3.0MHz Band QPSK	1/#Mid	1851.5	0.60	3.77	28.23	25.06	320.627	Horizontal	Pass
		1880	0.75	3.91	28.24	25.08	322.107	Horizontal	Pass
		1908.5	0.88	3.94	28.25	25.19	330.370	Horizontal	Pass
5.0MHz Band QPSK	1/#Mid	1852.5	0.71	3.77	28.31	25.25	334.965	Horizontal	Pass
		1880	1.09	3.91	28.22	25.40	346.737	Horizontal	Pass
		1907.5	1.16	3.94	28.20	25.42	348.337	Horizontal	Pass
10.0MHz Band QPSK	1/#Mid	1855	0.85	3.79	28.33	25.39	345.939	Horizontal	Pass
		1880	1.15	3.95	28.22	25.42	348.337	Horizontal	Pass
		1905	1.26	3.97	28.19	25.48	353.183	Horizontal	Pass
15.0MHz Band QPSK	1/#Mid	1857.5	0.89	3.79	28.34	25.44	349.945	Horizontal	Pass
		1880	1.10	3.95	28.22	25.37	344.350	Horizontal	Pass
		1902.5	1.24	3.97	28.18	25.45	350.752	Horizontal	Pass
20.0MHz Band QPSK	1/#Mid	1860	0.90	3.81	28.35	25.44	349.945	Horizontal	Pass
		1880	1.23	3.96	28.22	25.49	353.997	Horizontal	Pass
		1900	1.29	4.00	28.16	25.45	350.752	Horizontal	Pass
1.4MHz Band QPSK	1/#Mid	1850.7	-0.04	3.76	28.24	24.44	277.971	Vertical	Pass
		1880	0.53	3.91	28.22	24.84	304.789	Vertical	Pass
		1909.3	0.40	3.93	28.20	24.67	293.089	Vertical	Pass
3.0MHz Band QPSK	1/#Mid	1851.5	-0.34	3.77	28.23	24.12	258.226	Vertical	Pass
		1880	-0.26	3.91	28.24	24.07	255.270	Vertical	Pass
		1908.5	0.32	3.94	28.25	24.63	290.402	Vertical	Pass
5.0MHz Band QPSK	1/#Mid	1852.5	-0.42	3.77	28.31	24.12	258.226	Vertical	Pass
		1880	0.27	3.91	28.22	24.58	287.078	Vertical	Pass
		1907.5	-0.10	3.94	28.20	24.16	260.615	Vertical	Pass
10.0MHz Band QPSK	1/#Mid	1855	-0.25	3.79	28.33	24.29	268.534	Vertical	Pass
		1880	0.09	3.95	28.22	24.36	272.898	Vertical	Pass
		1905	0.03	3.97	28.19	24.25	266.073	Vertical	Pass

15.0MHz		1857.5	-0.45	3.79	28.34	24.10	257.040	Vertical	Pass
Band	1/#Mid	1880	0.50	3.95	28.22	24.77	299.916	Vertical	Pass
QPSK		1902.5	-0.29	3.97	28.18	23.92	246.604	Vertical	Pass
20.0MHz		1860	-0.46	3.81	28.35	24.08	255.859	Vertical	Pass
Band	1/#Mid	1880	0.53	3.96	28.22	24.79	301.301	Vertical	Pass
QPSK		1900	0.55	4.00	28.16	24.71	295.801	Vertical	Pass

Note:

SG Level= Signal generator output

Max. EIRP Average (dBm)= Antenna Gain(dB)+ SG Level (dBm)- Cable Loss(dBm)

Radiated Power (EIRP) for Band 2									
Mode	RB/RB SIZE	Frequency	Result						Conclusion
			SG Level (dBm)	Cable Loss (dBm)	Antenna Gain (dB)	Max. EIRP Average (dBm)	Max. EIRP Average (mW)	Polarization Of Max. ERP	
1.4MHz Band 16 QAM	1/#Mid	1850.7	-0.46	3.76	28.24	24.02	252.348	Horizontal	Pass
		1880	0.07	3.91	28.22	24.38	274.157	Horizontal	Pass
		1909.3	0.14	3.93	28.20	24.41	276.058	Horizontal	Pass
3.0MHz Band 16 QAM	1/#Mid	1851.5	0.04	3.77	28.23	24.50	281.838	Horizontal	Pass
		1880	-0.04	3.91	28.24	24.29	268.534	Horizontal	Pass
		1908.5	-0.25	3.94	28.25	24.06	254.683	Horizontal	Pass
5.0MHz Band 16 QAM	1/#Mid	1852.5	0.10	3.77	28.31	24.64	291.072	Horizontal	Pass
		1880	0.19	3.91	28.22	24.50	281.838	Horizontal	Pass
		1907.5	0.51	3.94	28.20	24.77	299.916	Horizontal	Pass
10.0MHz Band 16 QAM	1/#Mid	1855	0.05	3.79	28.33	24.59	287.740	Horizontal	Pass
		1880	0.06	3.95	28.22	24.33	271.019	Horizontal	Pass
		1905	0.59	3.97	28.19	24.81	302.691	Horizontal	Pass
15.0MHz Band 16 QAM	1/#Mid	1857.5	0.07	3.79	28.34	24.62	289.734	Horizontal	Pass
		1880	0.28	3.95	28.22	24.55	285.102	Horizontal	Pass
		1902.5	0.32	3.97	28.18	24.53	283.792	Horizontal	Pass
20.0MHz Band 16 QAM	1/#Mid	1860	0.18	3.81	28.35	24.72	296.483	Horizontal	Pass
		1880	0.48	3.96	28.22	24.74	297.852	Horizontal	Pass
		1900	0.66	4.00	28.16	24.82	303.389	Horizontal	Pass
1.4MHz Band 16 QAM	1/#Mid	1850.7	-1.30	3.76	28.24	23.18	207.970	Vertical	Pass
		1880	-0.68	3.91	28.22	23.63	230.675	Vertical	Pass
		1909.3	-1.38	3.93	28.20	22.89	194.536	Vertical	Pass
3.0MHz Band 16 QAM	1/#Mid	1851.5	-1.34	3.77	28.23	23.12	205.116	Vertical	Pass
		1880	-0.49	3.91	28.24	23.84	242.103	Vertical	Pass
		1908.5	-0.60	3.94	28.25	23.71	234.963	Vertical	Pass
5.0MHz Band 16 QAM	1/#Mid	1852.5	-1.13	3.77	28.31	23.41	219.280	Vertical	Pass
		1880	-0.68	3.91	28.22	23.63	230.675	Vertical	Pass
		1907.5	-1.18	3.94	28.20	23.08	203.236	Vertical	Pass
10.0MHz Band 16 QAM	1/#Mid	1855	-1.40	3.79	28.33	23.14	206.063	Vertical	Pass
		1880	-1.39	3.95	28.22	22.88	194.089	Vertical	Pass
		1905	-1.27	3.97	28.19	22.95	197.242	Vertical	Pass
15.0MHz Band 16 QAM	1/#Mid	1857.5	-1.04	3.79	28.34	23.51	224.388	Vertical	Pass
		1880	-0.96	3.95	28.22	23.31	214.289	Vertical	Pass
		1902.5	-0.71	3.97	28.18	23.50	223.872	Vertical	Pass

20.0MHz		1860	-1.03	3.81	28.35	23.51	224.388	Vertical	Pass
Band 16	1/#Mid	1880	-0.88	3.96	28.22	23.38	217.771	Vertical	Pass
QAM		1900	-0.99	4.00	28.16	23.17	207.491	Vertical	Pass

Note:

SG Level= Signal generator output

Max. EIRP Average (dBm)= Antenna Gain(dB)+ SG Level (dBm)- Cable Loss(dBm)

8.3 LTE BAND 4

Radiated Power (EIRP) for Band 4									
Mode	RB/RB SIZE	Frequency	Result						Conclusion
			SG Level (dBm)	Cable Loss (dBm)	Antenna Gain (dB)	Max. EIRP Average (dBm)	Max. EIRP Average (mW)	Polarization Of Max. ERP	
1.4MHz Band QPSK	1/#Mid	1710.7	0.05	3.12	27.58	24.51	282.488	Horizontal	Pass
		1732.5	0.06	3.27	27.61	24.40	275.423	Horizontal	Pass
		1754.3	0.08	3.29	27.63	24.42	276.694	Horizontal	Pass
3.0MHz Band QPSK	1/#Mid	1711.5	-0.12	3.13	27.61	24.36	272.898	Horizontal	Pass
		1732.5	-0.04	3.27	27.61	24.30	269.153	Horizontal	Pass
		1753.5	0.04	3.30	27.62	24.36	272.898	Horizontal	Pass
5.0MHz Band QPSK	1/#Mid	1712.5	0.11	3.13	27.63	24.61	289.068	Horizontal	Pass
		1732.5	0.21	3.27	27.61	24.55	285.102	Horizontal	Pass
		1752.5	0.33	3.30	27.60	24.63	290.402	Horizontal	Pass
10.0MHz Band QPSK	1/#Mid	1715	0.17	3.15	27.64	24.66	292.415	Horizontal	Pass
		1732.5	0.40	3.31	27.61	24.70	295.121	Horizontal	Pass
		1750	0.38	3.33	27.59	24.64	291.072	Horizontal	Pass
15.0MHz Band QPSK	1/#Mid	1717.5	0.16	3.15	27.65	24.66	292.415	Horizontal	Pass
		1732.5	0.32	3.31	27.61	24.62	289.734	Horizontal	Pass
		1747.5	0.38	3.33	27.57	24.62	289.734	Horizontal	Pass
20.0MHz Band QPSK	1/#Mid	1720	0.22	3.17	27.66	24.71	295.801	Horizontal	Pass
		1732.5	0.39	3.32	27.61	24.68	293.765	Horizontal	Pass
		1745	0.45	3.36	27.56	24.65	291.743	Horizontal	Pass
1.4MHz Band QPSK	1/#Mid	1710.7	-1.10	3.12	27.58	23.36	216.770	Vertical	Pass
		1732.5	-0.65	3.27	27.61	23.69	233.884	Vertical	Pass
		1754.3	-0.84	3.29	27.63	23.50	223.872	Vertical	Pass
3.0MHz Band QPSK	1/#Mid	1711.5	-0.75	3.13	27.61	23.73	236.048	Vertical	Pass
		1732.5	-0.38	3.27	27.61	23.96	248.886	Vertical	Pass
		1753.5	-0.28	3.30	27.62	24.04	253.513	Vertical	Pass
5.0MHz Band QPSK	1/#Mid	1712.5	-0.37	3.13	27.63	24.13	258.821	Vertical	Pass
		1732.5	-0.32	3.27	27.61	24.02	252.348	Vertical	Pass
		1752.5	-0.61	3.30	27.60	23.69	233.884	Vertical	Pass
10.0MHz Band QPSK	1/#Mid	1715	-0.73	3.15	27.64	23.76	237.684	Vertical	Pass
		1732.5	-0.48	3.31	27.61	23.82	240.991	Vertical	Pass
		1750	-0.50	3.33	27.59	23.76	237.684	Vertical	Pass

15.0MHz		1717.5	-0.56	3.15	27.65	23.94	247.742	Vertical	Pass
Band	1/#Mid	1732.5	-0.20	3.31	27.61	24.10	257.040	Vertical	Pass
QPSK		1747.5	-0.12	3.33	27.57	24.12	258.226	Vertical	Pass
20.0MHz		1720	-0.82	3.17	27.66	23.67	232.809	Vertical	Pass
Band	1/#Mid	1732.5	-0.37	3.32	27.61	23.92	246.604	Vertical	Pass
QPSK		1745	-0.38	3.36	27.56	23.82	240.991	Vertical	Pass

Note:

SG Level= Signal generator output

Max. EIRP Average (dBm)= Antenna Gain(dB)+ SG Level (dBm)- Cable Loss(dBm)

Radiated Power (EIRP) for Band 4									
Mode	RB/RB SIZE	Frequency	Result						Conclusion
			SG Level (dBm)	Cable Loss (dBm)	Antenna Gain (dB)	Max. EIRP Average (dBm)	Max. EIRP Average (mW)	Polarization Of Max. ERP	
1.4MHz Band 16 QAM	1/#Mid	1710.7	-0.76	3.12	27.58	23.70	234.423	Horizontal	Pass
		1732.5	-0.61	3.27	27.61	23.73	236.048	Horizontal	Pass
		1754.3	-0.61	3.29	27.63	23.73	236.048	Horizontal	Pass
3.0MHz Band 16 QAM	1/#Mid	1711.5	-0.70	3.13	27.61	23.78	238.781	Horizontal	Pass
		1732.5	-0.83	3.27	27.61	23.51	224.388	Horizontal	Pass
		1753.5	-1.05	3.30	27.62	23.27	212.324	Horizontal	Pass
5.0MHz Band 16 QAM	1/#Mid	1712.5	-0.53	3.13	27.63	23.97	249.459	Horizontal	Pass
		1732.5	-0.49	3.27	27.61	23.85	242.661	Horizontal	Pass
		1752.5	-0.18	3.30	27.60	24.12	258.226	Horizontal	Pass
10.0MHz Band 16 QAM	1/#Mid	1715	-0.60	3.15	27.64	23.89	244.906	Horizontal	Pass
		1732.5	-0.79	3.31	27.61	23.51	224.388	Horizontal	Pass
		1750	-0.17	3.33	27.59	24.09	256.448	Horizontal	Pass
15.0MHz Band 16 QAM	1/#Mid	1717.5	-0.40	3.15	27.65	24.10	257.040	Horizontal	Pass
		1732.5	-0.46	3.31	27.61	23.84	242.103	Horizontal	Pass
		1747.5	-0.48	3.33	27.57	23.76	237.684	Horizontal	Pass
20.0MHz Band 16 QAM	1/#Mid	1720	-0.35	3.17	27.66	24.14	259.418	Horizontal	Pass
		1732.5	-0.36	3.32	27.61	23.93	247.172	Horizontal	Pass
		1745	-0.17	3.36	27.56	24.03	252.930	Horizontal	Pass
1.4MHz Band 16 QAM	1/#Mid	1710.7	-2.17	3.12	27.58	22.29	169.434	Vertical	Pass
		1732.5	-1.34	3.27	27.61	23.00	199.526	Vertical	Pass
		1754.3	-1.45	3.29	27.63	22.89	194.536	Vertical	Pass
3.0MHz Band 16 QAM	1/#Mid	1711.5	-1.51	3.13	27.61	22.97	198.153	Vertical	Pass
		1732.5	-1.80	3.27	27.61	22.54	179.473	Vertical	Pass
		1753.5	-1.63	3.30	27.62	22.69	185.780	Vertical	Pass
5.0MHz Band 16 QAM	1/#Mid	1712.5	-2.29	3.13	27.63	22.21	166.341	Vertical	Pass
		1732.5	-1.54	3.27	27.61	22.80	190.546	Vertical	Pass
		1752.5	-1.45	3.30	27.60	22.85	192.752	Vertical	Pass
10.0MHz Band 16 QAM	1/#Mid	1715	-1.70	3.15	27.64	22.79	190.108	Vertical	Pass
		1732.5	-1.99	3.31	27.61	22.31	170.216	Vertical	Pass
		1750	-1.16	3.33	27.59	23.10	204.174	Vertical	Pass
15.0MHz Band 16 QAM	1/#Mid	1717.5	-1.76	3.15	27.65	22.74	187.932	Vertical	Pass
		1732.5	-1.50	3.31	27.61	22.80	190.546	Vertical	Pass
		1747.5	-1.39	3.33	27.57	22.85	192.752	Vertical	Pass

20.0MHz		1720	-1.89	3.17	27.66	22.60	181.970	Vertical	Pass
Band 16	1/#Mid	1732.5	-1.26	3.32	27.61	23.03	200.909	Vertical	Pass
QAM		1745	-2.02	3.36	27.56	22.18	165.196	Vertical	Pass

Note:

SG Level= Signal generator output

Max. EIRP Average (dBm)= Antenna Gain(dB)+ SG Level (dBm)- Cable Loss(dBm)

8.4 LTE BAND 5

Radiated Power (ERP) for Band 5										
Mode	RB/RB SIZE	Frequency	Result							Conclusion
			SG Level (dBm)	Cable Loss (dBm)	Antenna Gain (dB)	Correction (dB)	Max. ERP Average (dBm)	Max. ERP Average (mW)	Polarization Of Max. ERP	
1.4MHz Band QPSK	1/#Midd	824.7	8.94	2.01	19.68	2.15	24.46	279.254	Horizontal	Pass
		836.5	8.82	2.01	19.77	2.15	24.43	277.332	Horizontal	Pass
		848.3	8.62	2.02	19.82	2.15	24.27	267.301	Horizontal	Pass
3.0MHz Band QPSK	1/#Midd	825.5	8.71	2.01	19.70	2.15	24.25	266.073	Horizontal	Pass
		836.5	8.61	2.01	19.77	2.15	24.22	264.241	Horizontal	Pass
		847.5	8.48	2.02	19.81	2.15	24.12	258.226	Horizontal	Pass
5.0MHz Band QPSK	1/#Midd	826.5	8.99	2.01	19.71	2.15	24.54	284.446	Horizontal	Pass
		836.5	8.87	2.01	19.77	2.15	24.48	280.543	Horizontal	Pass
		846.5	8.71	2.02	19.79	2.15	24.33	271.019	Horizontal	Pass
10.0MHz Band QPSK	1/#Midd	829	9.01	2.01	19.73	2.15	24.58	287.078	Horizontal	Pass
		836.5	8.96	2.01	19.77	2.15	24.57	286.418	Horizontal	Pass
		844	8.86	2.02	19.78	2.15	24.47	279.898	Horizontal	Pass
1.4MHz Band QPSK	1/#Midd	824.7	8.15	2.01	19.68	2.15	23.67	232.809	Vertical	Pass
		836.5	7.73	2.01	19.77	2.15	23.34	215.774	Vertical	Pass
		848.3	7.21	2.02	19.82	2.15	22.86	193.197	Vertical	Pass
3.0MHz Band QPSK	1/#Midd	825.5	7.90	2.01	19.70	2.15	23.44	220.800	Vertical	Pass
		836.5	8.06	2.01	19.77	2.15	23.67	232.809	Vertical	Pass
		847.5	7.88	2.02	19.81	2.15	23.52	224.905	Vertical	Pass
5.0MHz Band QPSK	1/#Midd	826.5	7.61	2.01	19.71	2.15	23.16	207.014	Vertical	Pass
		836.5	7.61	2.01	19.77	2.15	23.22	209.894	Vertical	Pass
		846.5	7.63	2.02	19.79	2.15	23.25	211.349	Vertical	Pass
10.0MHz Band QPSK	1/#Midd	829	7.74	2.01	19.73	2.15	23.31	214.289	Vertical	Pass
		836.5	7.96	2.01	19.77	2.15	23.57	227.510	Vertical	Pass
		844	7.94	2.02	19.78	2.15	23.55	226.464	Vertical	Pass

Radiated Power (ERP) for Band 5										
Mode	RB/RB SIZE	Frequency	Result							Conclusion
			SG Level (dBm)	Cable Loss (dBm)	Antenna Gain (dB)	Correction (dB)	Max. ERP Average (dBm)	Max. ERP Average (mW)	Polarization Of Max. ERP	
1.4MHz Band 16 QAM	1/#Midd	824.7	8.09	2.01	19.68	2.15	23.61	229.615	Horizontal	Pass
		836.5	8.02	2.01	19.77	2.15	23.63	230.675	Horizontal	Pass
		848.3	7.86	2.02	19.82	2.15	23.51	224.388	Horizontal	Pass
3.0MHz Band 16 QAM	1/#Midd	825.5	8.17	2.01	19.70	2.15	23.71	234.963	Horizontal	Pass
		836.5	7.88	2.01	19.77	2.15	23.49	223.357	Horizontal	Pass
		847.5	7.36	2.02	19.81	2.15	23.00	199.526	Horizontal	Pass
5.0MHz Band 16 QAM	1/#Midd	826.5	8.49	2.01	19.71	2.15	24.04	253.513	Horizontal	Pass
		836.5	8.26	2.01	19.77	2.15	23.87	243.781	Horizontal	Pass
		846.5	8.01	2.02	19.79	2.15	23.63	230.675	Horizontal	Pass
10.0MHz Band 16 QAM	1/#Midd	829	8.49	2.01	19.73	2.15	24.06	254.683	Horizontal	Pass
		836.5	8.21	2.01	19.77	2.15	23.82	240.991	Horizontal	Pass
		844	7.75	2.02	19.78	2.15	23.36	216.770	Horizontal	Pass
1.4MHz Band 16 QAM	1/#Midd	824.7	6.36	2.01	19.68	2.15	21.88	154.170	Vertical	Pass
		836.5	8.13	2.01	19.77	2.15	23.74	236.592	Vertical	Pass
		848.3	7.85	2.02	19.82	2.15	23.50	223.872	Vertical	Pass
3.0MHz Band 16 QAM	1/#Midd	825.5	7.52	2.01	19.70	2.15	23.06	202.302	Vertical	Pass
		836.5	6.54	2.01	19.77	2.15	22.15	164.059	Vertical	Pass
		847.5	7.44	2.02	19.81	2.15	23.08	203.236	Vertical	Pass
5.0MHz Band 16 QAM	1/#Midd	826.5	7.03	2.01	19.71	2.15	22.58	181.134	Vertical	Pass
		836.5	6.20	2.01	19.77	2.15	21.81	151.705	Vertical	Pass
		846.5	6.51	2.02	19.79	2.15	22.13	163.305	Vertical	Pass
10.0MHz Band 16 QAM	1/#Midd	829	6.72	2.01	19.73	2.15	22.29	169.434	Vertical	Pass
		836.5	7.67	2.01	19.77	2.15	23.28	212.814	Vertical	Pass
		844	7.08	2.02	19.78	2.15	22.69	185.780	Vertical	Pass

Note:

ERP=EIRP-2.15

SG Level= Signal generator output

Max. EIRP Average (dBm)= Antenna Gain(dB)+ SG Level (dBm)- Cable Loss(dBm)

8.5 LTE BAND 7

Radiated Power (EIRP) for Band 7									
Mode	RB/RB SIZE	Frequency	Result						Conclusion
			SG Level (dBm)	Cable Loss (dBm)	Antenna Gain (dB)	Max. EIRP Average (dBm)	Max. EIRP Average (mW)	Polarization Of Max. ERP	
5.0MHz Band QPSK	1/#Mid	2502.5	1.93	4.54	27.75	25.14	326.588	Horizontal	Pass
		2535	2.10	4.69	27.72	25.13	325.837	Horizontal	Pass
		2567.5	2.17	4.71	27.71	25.17	328.852	Horizontal	Pass
10.0MHz Band QPSK	1/#Mid	2505	2.00	4.55	27.76	25.21	331.894	Horizontal	Pass
		2535	2.19	4.69	27.72	25.22	332.660	Horizontal	Pass
		2565	2.27	4.72	27.70	25.25	334.965	Horizontal	Pass
15.0MHz Band QPSK	1/#Mid	2507.5	1.99	4.55	27.77	25.21	331.894	Horizontal	Pass
		2535	2.13	4.69	27.72	25.16	328.095	Horizontal	Pass
		2562.5	2.23	4.72	27.69	25.20	331.131	Horizontal	Pass
20.0MHz Band QPSK	1/#Mid	2510	2.05	4.57	27.78	25.26	335.738	Horizontal	Pass
		2535	2.23	4.73	27.72	25.22	332.660	Horizontal	Pass
		2560	2.27	4.75	27.68	25.20	331.131	Horizontal	Pass
5.0MHz Band QPSK	1/#Mid	2502.5	0.18	4.54	27.75	23.39	218.273	Vertical	Pass
		2535	0.78	4.69	27.72	23.81	240.436	Vertical	Pass
		2567.5	0.88	4.71	27.71	23.88	244.343	Vertical	Pass
10.0MHz Band QPSK	1/#Mid	2505	0.65	4.55	27.76	23.86	243.220	Vertical	Pass
		2535	0.73	4.69	27.72	23.76	237.684	Vertical	Pass
		2565	0.35	4.72	27.70	23.33	215.278	Vertical	Pass
15.0MHz Band QPSK	1/#Mid	2507.5	0.99	4.55	27.77	24.21	263.633	Vertical	Pass
		2535	0.96	4.69	27.72	23.99	250.611	Vertical	Pass
		2562.5	0.80	4.72	27.69	23.77	238.232	Vertical	Pass
20.0MHz Band QPSK	1/#Mid	2510	0.63	4.57	27.78	23.84	242.103	Vertical	Pass
		2535	1.05	4.73	27.72	24.04	253.513	Vertical	Pass
		2560	0.56	4.75	27.68	23.49	223.357	Vertical	Pass

Radiated Power (EIRP) for Band 7									
Mode	RB/RB SIZE	Frequency	Result						Conclusion
			SG Level (dBm)	Cable Loss (dBm)	Antenna Gain (dB)	Max. EIRP Average (dBm)	Max. EIRP Average (mW)	Polarization Of Max. ERP	
5.0MHz Band 16 QAM	1/#Mid	2502.5	1.24	4.54	27.75	24.45	278.612	Horizontal	Pass
		2535	1.55	4.69	27.72	24.58	287.078	Horizontal	Pass
		2567.5	1.47	4.71	27.71	24.47	279.898	Horizontal	Pass
10.0MHz Band 16 QAM	1/#Mid	2505	1.35	4.55	27.76	24.56	285.759	Horizontal	Pass
		2535	1.34	4.69	27.72	24.37	273.527	Horizontal	Pass
		2565	1.07	4.72	27.70	24.05	254.097	Horizontal	Pass
15.0MHz Band 16 QAM	1/#Mid	2507.5	1.17	4.55	27.77	24.39	274.789	Horizontal	Pass
		2535	1.20	4.69	27.72	24.23	264.850	Horizontal	Pass
		2562.5	1.59	4.72	27.69	24.56	285.759	Horizontal	Pass
20.0MHz Band 16 QAM	1/#Mid	2510	1.29	4.57	27.78	24.50	281.838	Horizontal	Pass
		2535	1.62	4.73	27.72	24.61	289.068	Horizontal	Pass
		2560	1.52	4.75	27.68	24.45	278.612	Horizontal	Pass
5.0MHz Band 16 QAM	1/#Mid	2502.5	0.43	4.54	27.75	23.64	231.206	Vertical	Pass
		2535	0.71	4.69	27.72	23.74	236.592	Vertical	Pass
		2567.5	-0.12	4.71	27.71	22.88	194.089	Vertical	Pass
10.0MHz Band 16 QAM	1/#Mid	2505	0.33	4.55	27.76	23.54	225.944	Vertical	Pass
		2535	0.82	4.69	27.72	23.85	242.661	Vertical	Pass
		2565	1.23	4.72	27.70	24.21	263.633	Vertical	Pass
15.0MHz Band 16 QAM	1/#Mid	2507.5	0.54	4.55	27.77	23.76	237.684	Vertical	Pass
		2535	0.92	4.69	27.72	23.95	248.313	Vertical	Pass
		2562.5	-0.23	4.72	27.69	22.74	187.932	Vertical	Pass
20.0MHz Band 16 QAM	1/#Mid	2510	-0.50	4.57	27.78	22.71	186.638	Vertical	Pass
		2535	-0.27	4.73	27.72	22.72	187.068	Vertical	Pass
		2560	-0.52	4.75	27.68	22.41	174.181	Vertical	Pass

Note:

SG Level= Signal generator output

Max. EIRP Average (dBm)= Antenna Gain(dB)+ SG Level (dBm)- Cable Loss(dBm)

8.6 LTE BAND 17

Radiated Power (ERP) for Band 17										
Mode	RB/RB SIZE	Frequency	Result							Conclusion
			SG Level (dBm)	Cable Loss (dBm)	Antenna Gain (dB)	Correction (dB)	Max. ERP Average (dBm)	Max. ERP Average (mW)	Polarization Of Max. ERP	
5.0MHz Band QPSK	1/#Midd	706.5	9.54	1.91	19.23	2.15	24.71	295.801	Vertical	Pass
		710	9.40	1.91	19.26	2.15	24.60	288.403	Vertical	Pass
		713.5	9.30	1.92	19.33	2.15	24.56	285.759	Vertical	Pass
10.0MHz Band QPSK	1/#Midd	709	9.55	1.91	19.25	2.15	24.74	297.852	Vertical	Pass
		710	9.50	1.91	19.26	2.15	24.70	295.121	Vertical	Pass
		711	9.46	1.92	19.32	2.15	24.71	295.801	Vertical	Pass
5.0MHz Band QPSK	1/#Midd	706.5	7.86	1.91	19.23	2.15	23.03	200.909	Horizontal	Pass
		710	7.62	1.91	19.26	2.15	22.82	191.426	Horizontal	Pass
		713.5	8.11	1.92	19.33	2.15	23.37	217.270	Horizontal	Pass
10.0MHz Band QPSK	1/#Midd	709	7.75	1.91	19.25	2.15	22.94	196.789	Horizontal	Pass
		710	8.26	1.91	19.26	2.15	23.46	221.820	Horizontal	Pass
		711	7.73	1.92	19.32	2.15	22.98	198.609	Horizontal	Pass

Radiated Power (ERP) for Band 17										
Mode	RB/RB SIZE	Frequency	Result							Conclusion
			SG Level (dBm)	Cable Loss (dBm)	Antenna Gain (dB)	Correction (dB)	Max. ERP Average (dBm)	Max. ERP Average (mW)	Polarization Of Max. ERP	
5.0MHz Band 16 QAM	1/#Midd	706.5	8.89	1.91	19.23	2.15	24.06	254.683	Vertical	Pass
		710	8.80	1.91	19.26	2.15	24.00	251.189	Vertical	Pass
		713.5	8.60	1.92	19.33	2.15	23.86	243.220	Vertical	Pass
10.0MHz Band 16 QAM	1/#Midd	709	8.43	1.91	19.25	2.15	23.62	230.144	Vertical	Pass
		710	8.96	1.91	19.26	2.15	24.16	260.615	Vertical	Pass
		711	8.69	1.92	19.32	2.15	23.94	247.742	Vertical	Pass
5.0MHz Band 16 QAM	1/#Midd	706.5	7.76	1.91	19.23	2.15	22.93	196.336	Horizontal	Pass
		710	7.42	1.91	19.26	2.15	22.62	182.810	Horizontal	Pass
		713.5	8.08	1.92	19.33	2.15	23.34	215.774	Horizontal	Pass
10.0MHz Band 16 QAM	1/#Midd	709	7.83	1.91	19.25	2.15	23.02	200.447	Horizontal	Pass
		710	7.63	1.91	19.26	2.15	22.83	191.867	Horizontal	Pass
		711	7.56	1.92	19.32	2.15	22.81	190.985	Horizontal	Pass

Note:

ERP=EIRP-2.15

SG Level= Signal generator output

Max. EIRP Average (dBm)= Antenna Gain(dB)+ SG Level (dBm)- Cable Loss(dBm)

8.7 LTE BAND 66

Radiated Power (EIRP) for Band 66									
Mode	RB/RB SIZE	Frequency	Result						Conclusion
			SG Level (dBm)	Cable Loss (dBm)	Antenna Gain (dB)	Max. EIRP Average (dBm)	Max. EIRP Average (mW)	Polarization Of Max. ERP	
1.4MHz Band QPSK	6/0	1710.7	0.27	3.76	28.24	24.75	298.538	Horizontal	Pass
		1745	0.41	3.91	28.22	24.72	296.483	Horizontal	Pass
		1779.3	0.54	3.93	28.2	24.81	302.691	Horizontal	Pass
3.0MHz Band QPSK	15/0	1711.5	0.21	3.77	28.23	24.67	293.089	Horizontal	Pass
		1745	0.30	3.91	28.24	24.63	290.402	Horizontal	Pass
		1778.5	0.28	3.94	28.25	24.59	287.740	Horizontal	Pass
5.0MHz Band QPSK	25/0	1712.5	0.31	3.77	28.31	24.85	305.492	Horizontal	Pass
		1745	0.63	3.91	28.22	24.94	311.889	Horizontal	Pass
		1777.5	0.57	3.94	28.2	24.83	304.089	Horizontal	Pass
10.0MHz Band QPSK	50/0	1715	0.42	3.79	28.33	24.96	313.329	Horizontal	Pass
		1745	0.69	3.95	28.22	24.96	313.329	Horizontal	Pass
		1775	0.68	3.97	28.19	24.90	309.030	Horizontal	Pass
15.0MHz Band QPSK	75/0	1717.5	0.40	3.79	28.34	24.95	312.608	Horizontal	Pass
		1745	0.59	3.95	28.22	24.86	306.196	Horizontal	Pass
		1772.5	0.64	3.97	28.18	24.85	305.492	Horizontal	Pass
20.0MHz Band QPSK	100/0	1720	0.43	3.81	28.35	24.97	314.051	Horizontal	Pass
		1745	0.69	3.96	28.22	24.95	312.608	Horizontal	Pass
		1770	0.67	4	28.16	24.83	304.089	Horizontal	Pass
1.4MHz Band QPSK	6/0	1710.7	-1.22	3.76	28.24	23.26	211.836	Vertical	Pass
		1745	-0.64	3.91	28.22	23.67	232.809	Vertical	Pass
		1779.3	-0.30	3.93	28.2	23.97	249.459	Vertical	Pass
3.0MHz Band QPSK	15/0	1711.5	-0.29	3.77	28.23	24.17	261.216	Vertical	Pass
		1745	-0.55	3.91	28.24	23.78	238.781	Vertical	Pass
		1778.5	-1.05	3.94	28.25	23.26	211.836	Vertical	Pass
5.0MHz Band QPSK	25/0	1712.5	-1.02	3.77	28.31	23.52	224.905	Vertical	Pass
		1745	-0.61	3.91	28.22	23.70	234.423	Vertical	Pass
		1777.5	-0.28	3.94	28.2	23.98	250.035	Vertical	Pass
10.0MHz Band	50/0	1715	-0.37	3.79	28.34	24.18	261.818	Vertical	Pass
		1745	-0.23	3.95	28.22	24.04	253.513	Vertical	Pass

QPSK		1775	-0.26	3.97	28.18	23.95	248.313	Vertical	Pass
15.0MHz	75/0	1717.5	-0.46	3.81	28.35	24.08	255.859	Vertical	Pass
Band		1745	-0.84	3.96	28.22	23.42	219.786	Vertical	Pass
QPSK		1772.5	-0.56	4	28.16	23.60	229.087	Vertical	Pass
20.0MHz	100/0	1720	-0.44	3.79	28.34	24.11	257.632	Vertical	Pass
Band		1745	-0.62	3.95	28.22	23.65	231.739	Vertical	Pass
QPSK		1770	-0.58	3.97	28.18	23.63	230.675	Vertical	Pass

Note:

SG Level= Signal generator output

Max. EIRP Average (dBm)= Antenna Gain(dB)+ SG Level (dBm)- Cable Loss(dBm)

Radiated Power (EIRP) for Band 66									
Mode	RB/RB SIZE	Frequency	Result						Conclusion
			SG Level (dBm)	Cable Loss (dBm)	Antenna Gain (dB)	Max. EIRP Average (dBm)	Max. EIRP Average (mW)	Polarization Of Max. ERP	
1.4MHz Band 16 QAM	6/0	1710.7	-0.56	3.76	28.24	23.92	246.604	Horizontal	Pass
		1745	-0.17	3.91	28.22	24.14	259.418	Horizontal	Pass
		1779.3	-0.35	3.93	28.2	23.92	246.604	Horizontal	Pass
3.0MHz Band 16 QAM	15/0	1711.5	-0.95	3.77	28.23	23.51	224.388	Horizontal	Pass
		1745	-0.20	3.91	28.24	24.13	258.821	Horizontal	Pass
		1778.5	-0.49	3.94	28.25	23.82	240.991	Horizontal	Pass
5.0MHz Band 16 QAM	25/0	1712.5	-0.37	3.77	28.31	24.17	261.216	Horizontal	Pass
		1745	-0.43	3.91	28.22	23.88	244.343	Horizontal	Pass
		1777.5	-0.10	3.94	28.2	24.16	260.615	Horizontal	Pass
10.0MHz Band 16 QAM	50/0	1715	-0.42	3.79	28.33	24.12	258.226	Horizontal	Pass
		1745	-0.08	3.95	28.22	24.19	262.422	Horizontal	Pass
		1775	-0.40	3.97	28.19	23.82	240.991	Horizontal	Pass
15.0MHz Band 16 QAM	75/0	1717.5	-0.41	3.79	28.34	24.14	259.418	Horizontal	Pass
		1745	-0.23	3.95	28.22	24.04	253.513	Horizontal	Pass
		1772.5	-0.02	3.97	28.18	24.19	262.422	Horizontal	Pass
20.0MHz Band 16 QAM	100/0	1720	-0.24	3.81	28.35	24.30	269.153	Horizontal	Pass
		1745	-0.02	3.96	28.22	24.24	265.461	Horizontal	Pass
		1770	0.04	4	28.16	24.20	263.027	Horizontal	Pass
1.4MHz Band 16 QAM	6/0	1710.7	-2.11	3.76	28.24	22.37	172.584	Vertical	Pass
		1745	-1.19	3.91	28.22	23.12	205.116	Vertical	Pass
		1779.3	-1.08	3.93	28.2	23.19	208.449	Vertical	Pass
3.0MHz Band 16 QAM	15/0	1711.5	-1.75	3.77	28.23	22.71	186.638	Vertical	Pass
		1745	-1.54	3.91	28.24	22.79	190.108	Vertical	Pass
		1778.5	-1.66	3.94	28.25	22.65	184.077	Vertical	Pass
5.0MHz Band 16 QAM	25/0	1712.5	-1.49	3.77	28.31	23.05	201.837	Vertical	Pass
		1745	-1.86	3.91	28.22	22.45	175.792	Vertical	Pass
		1777.5	-2.02	3.94	28.2	22.24	167.494	Vertical	Pass
10.0MHz Band 16 QAM	50/0	1715	-0.40	3.79	28.34	24.15	260.016	Vertical	Pass
		1745	-0.79	3.95	28.22	23.48	222.844	Vertical	Pass
		1775	-0.37	3.97	28.18	23.84	242.103	Vertical	Pass
15.0MHz Band 16 QAM	75/0	1717.5	-2.12	3.81	28.35	22.42	174.582	Vertical	Pass
		1745	-0.11	3.96	28.22	24.15	260.016	Vertical	Pass
		1772.5	-0.93	4	28.16	23.23	210.378	Vertical	Pass

20.0MHz		1720	-1.35	3.79	28.34	23.20	208.930	Vertical	Pass
Band 16	100/0	1745	-0.78	3.95	28.22	23.49	223.357	Vertical	Pass
QAM		1770	-0.70	3.97	28.18	23.51	224.388	Vertical	Pass

Note:

SG Level= Signal generator output

Max. EIRP Average (dBm)= Antenna Gain(dB)+ SG Level (dBm)- Cable Loss(dBm)

9. SPURIOUS RADIATION EMISSION

RULE PART(S)

FCC: §2.1051, §22.917(a), §24.238(a), §27.53(c)(g)(h)(m)

LIMIT

For Band 7, the minimum permissible attenuation level of any spurious emission is $55 + \log_{10}(P)$ [Watts].

The minimum permissible attenuation level of any spurious emission is $43 + \log_{10}(P)$ [Watts], where P is the transmitter power in Watts.

TEST PROCEDURE

For Cellular equipment - Compliance with these rules is based on the use of measurement instrumentation employing a resolution bandwidth of 100 kHz or greater. In the 1 MHz bands immediately outside and adjacent to the frequency block a resolution bandwidth of at least one percent of the emission bandwidth of the fundamental emission of the transmitter may be employed. A narrower resolution bandwidth is permitted in all cases to improve measurement accuracy provided the measured power is integrated over the full required measurement bandwidth (i.e. 100 kHz or 1 percent of emission bandwidth, as specified). The emission bandwidth is defined as the width of the signal between two points, one below the carrier center frequency and one above the carrier center frequency, outside of which all emissions are attenuated at least 26 dB below the transmitter power.

For PCS equipment - Compliance with these rules is based on the use of measurement instrumentation employing a resolution bandwidth of 1 MHz or greater. However, in the 1 MHz bands immediately outside and adjacent to the frequency block a resolution bandwidth of at least one percent of the emission bandwidth of the fundamental emission of the transmitter may be employed. A narrower resolution bandwidth is permitted in all cases to improve measurement accuracy provided the measured power is integrated over the full required measurement bandwidth (i.e. 1 MHz or 1 percent of emission bandwidth, as specified). The emission bandwidth is defined as the width of the signal between two points, one below the carrier center frequency and one above the carrier center frequency, outside of which all emissions are attenuated at least 26 dB below the transmitter power.

The unwanted emission power shall be measured with a resolution bandwidth of at least 1% of the occupied bandwidth in the 1 MHz band immediately outside and adjacent to the channel edge of the equipment. Beyond the 1 MHz band immediately outside the channel edge of the equipment, a resolution bandwidth of 1 MHz shall be employed. A narrower resolution bandwidth is allowed to be used provided that the measured power is integrated over the full required measurement bandwidth of 1 MHz or 1% of the occupied bandwidth as applicable.

The power of any unwanted emissions measured from the channel edge of the equipment shall be attenuated below the transmitter power, P (dBW), as follows:

- a. for base station and subscriber equipment, other than mobile subscriber equipment, the attenuation shall not be less than $43 + 10 \text{ Log}_{10} (p)$, dB; and
- b. for mobile subscriber equipment, the attenuation shall not be less than $43 + 10 \text{ Log}_{10} (p)$, dB at the channel edges and $55 + 10 \text{ Log}_{10} (p)$ at 5.5 MHz away and beyond the channel edges where p in (a) and (b) is the transmitter power measured in watts.

MODES TESTED

- LTE Band 2
- LTE Band 4
- LTE Band 5
- LTE Band 7
- LTE Band 17
- LTE Band 66

RESULTS

PASS

9.1 LTE BAND 2

QPSK EIRP POWER FOR LTE BAND 2 (1.4MHZ BANDWIDTH)

Test Results for Low Channel 1710.7MHz							
Frequency(MHz)	SG Level(dBm)	Cable Loss(dB)	Antenna Gain(dB)	Absolute Level(dBm)	Limit (dBm)	Margin(dBm)	Polarity
3701.4	-53.08	4.04	33.51	-23.61	-13	-10.61	Horizontal
3701.4	-50.15	4.04	33.51	-20.68	-13	-7.68	Vertical
5552.1	-47.53	5.24	35.84	-16.93	-13	-3.93	Vertical
5552.1	-51.74	5.24	35.84	-21.14	-13	-8.14	Horizontal
188.491	-36.95	1.43	16.02	-22.36	-13	-9.36	Vertical
407.106	-37.71	1.30	17.99	-21.02	-13	-8.02	Horizontal
Test Results for Mid Channel 1732.5MHz							
3760.0	-50.78	4.04	33.56	-21.26	-13	-8.26	Horizontal
3760.0	-48.80	4.04	33.56	-19.28	-13	-6.28	Vertical
5640.0	-51.67	5.24	35.91	-21.00	-13	-8.00	Vertical
5640.0	-53.62	5.24	35.91	-22.95	-13	-9.95	Horizontal
205.356	-40.80	1.62	16.97	-25.45	-13	-12.45	Vertical
409.306	-43.12	1.74	15.98	-28.89	-13	-15.89	Horizontal
Test Results for High Channel 1754.3MHz							
3818.6	-51.54	4.04	34.00	-21.58	-13	-8.58	Horizontal
3818.6	-48.05	4.04	34.00	-18.09	-13	-5.09	Vertical
5727.9	-50.09	5.24	36.04	-19.29	-13	-6.29	Vertical
5727.9	-49.27	5.24	36.04	-18.47	-13	-5.47	Horizontal
201.809	-43.47	1.42	17.29	-27.60	-13	-14.60	Vertical
466.005	-40.38	1.50	17.90	-23.97	-13	-10.97	Horizontal

QPSK EIRP POWER FOR LTE BAND 2 (20.0MHZ BANDWIDTH)

Test Results for Low Channel 1710.7MHz							
Frequency(MHz)	SG Level(dBm)	Cable Loss(dB)	Antenna Gain(dB)	Absolute Level(dBm)	Limit (dBm)	Margin(dBm)	Polarity
3720.0	-44.99	4.07	33.54	-15.52	-13	-2.52	Horizontal
3720.0	-50.66	4.07	33.54	-21.19	-13	-8.19	Vertical
5580.0	-51.04	5.28	35.86	-20.46	-13	-7.46	Vertical
5580.0	-53.05	5.28	35.86	-22.47	-13	-9.47	Horizontal
207.162	-41.77	1.58	16.89	-26.45	-13	-13.45	Vertical
433.01	-41.27	1.76	17.26	-25.77	-13	-12.77	Horizontal
Test Results for Mid Channel 1732.5MHz							
3760.0	-49.13	4.04	33.56	-19.61	-13	-6.61	Horizontal
3760.0	-44.96	4.04	33.56	-15.44	-13	-2.44	Vertical
5640.0	-51.07	5.24	35.91	-20.40	-13	-7.40	Vertical
5640.0	-50.19	5.24	35.91	-19.52	-13	-6.52	Horizontal
191.745	-36.16	1.46	16.27	-21.35	-13	-8.35	Vertical
325.472	-39.92	1.59	15.15	-26.36	-13	-13.36	Horizontal
Test Results for High Channel 1754.3MHz							
3800.0	-50.01	4.04	34.00	-20.05	-13	-7.05	Horizontal
3800.0	-49.29	4.04	34.00	-19.33	-13	-6.33	Vertical
5700.0	-46.53	5.24	36.04	-15.73	-13	-2.73	Vertical
5700.0	-53.03	5.24	36.04	-22.23	-13	-9.23	Horizontal
186.439	-41.83	1.36	17.39	-25.79	-13	-12.79	Vertical
404.866	-44.01	1.66	15.39	-30.28	-13	-17.28	Horizontal

Note: P_{Mea}(dBm)= Power(dBm)+ ARpl (dBm)

. Over Limit= : P_{Mea}(dBm)-Limit(dBm)

. Both QPSK and 16QAM has been tested, the worst case is QPSK mode, the report just reported the worst case.

9.2 LTE BAND 4

QPSK EIRP POWER FOR LTE BAND 4 (1.4MHZ BANDWIDTH)

Test Results for Low Channel 1710.7MHz							
Frequency(MHz)	SG Level(dBm)	Cable Loss(dB)	Antenna Gain(dB)	Absolute Level(dBm)	Limit (dBm)	Margin(dBm)	Polarity
3421.4	-51.55	4.02	29.80	-25.77	-13	-12.77	Horizontal
3421.4	-53.14	4.02	29.80	-27.36	-13	-14.36	Vertical
5132.1	-53.57	5.24	35.84	-22.97	-13	-9.97	Vertical
5132.1	-52.55	5.24	35.84	-21.95	-13	-8.95	Horizontal
200.195	-41.03	1.68	16.04	-26.67	-13	-13.67	Vertical
311.432	-44.95	1.78	17.74	-28.99	-13	-15.99	Horizontal
Test Results for Mid Channel 1732.5MHz							
3465.0	-51.10	4.03	30.00	-25.13	-13	-12.13	Horizontal
3465.0	-45.27	4.03	30.00	-19.30	-13	-6.30	Vertical
5197.5	-45.73	5.25	35.86	-15.12	-13	-2.12	Vertical
5197.5	-52.93	5.25	35.86	-22.32	-13	-9.32	Horizontal
207.39	-44.90	1.72	17.69	-28.93	-13	-15.93	Vertical
321.306	-38.95	1.62	16.02	-24.54	-13	-11.54	Horizontal
Test Results for High Channel 1754.3MHz							
3508.6	-44.19	4.05	30.01	-18.23	-13	-5.23	Horizontal
3508.6	-50.30	4.05	30.01	-24.34	-13	-11.34	Vertical
5262.9	-52.10	5.26	35.86	-21.50	-13	-8.50	Vertical
5262.9	-49.07	5.26	35.86	-18.47	-13	-5.47	Horizontal
196.837	-43.14	1.80	16.69	-28.25	-13	-15.25	Vertical
443.334	-39.44	1.75	16.66	-24.54	-13	-11.54	Horizontal

QPSK EIRP POWER FOR LTE BAND 4 (20.0MHZ BANDWIDTH)

Test Results for Low Channel 1720MHz							
Frequency(MHz)	SG Level(dBm)	Cable Loss(dB)	Antenna Gain(dB)	Absolute Level(dBm)	Limit (dBm)	Margin(dBm)	Polarity
3440.0	-53.65	4.02	29.80	-27.87	-13	-14.87	Horizontal
3440.0	-44.46	4.02	29.80	-18.68	-13	-5.68	Vertical
5160.0	-51.07	5.24	35.84	-20.47	-13	-7.47	Vertical
5160.0	-50.25	5.24	35.84	-19.65	-13	-6.65	Horizontal
212.483	-38.75	1.57	17.26	-23.06	-13	-10.06	Vertical
257.535	-38.21	1.78	16.35	-23.64	-13	-10.64	Horizontal
Test Results for Mid Channel 1732.5MHz							
3465.0	-53.91	4.03	30.00	-27.94	-13	-14.94	Horizontal
3465.0	-49.34	4.03	30.00	-23.37	-13	-10.37	Vertical
5197.5	-47.22	5.25	35.86	-16.61	-13	-3.61	Vertical
5197.5	-50.84	5.25	35.86	-20.23	-13	-7.23	Horizontal
189.61	-39.81	1.44	17.95	-23.30	-13	-10.30	Vertical
325.308	-38.56	1.65	16.09	-24.12	-13	-11.12	Horizontal
Test Results for High Channel 1745MHz							
3490.0	-53.62	2.91	27.68	-28.85	-13	-15.85	Horizontal
3490.0	-47.99	2.91	27.68	-23.22	-13	-10.22	Vertical
5235.0	-49.18	5.26	35.86	-18.58	-13	-5.58	Vertical
5235.0	-50.01	5.26	35.86	-19.41	-13	-6.41	Horizontal
176.292	-43.52	1.61	16.85	-28.28	-13	-15.28	Vertical
428.437	-39.14	1.61	15.19	-25.56	-13	-12.56	Horizontal

Note: P_{Mea}(dBm)= Power(dBm)+ ARpl (dBm)

Over Limit= : P_{Mea}(dBm)-Limit(dBm)

Both QPSK and 16QAM has been tested, the worst case is QPSK mode, the report just reported the worst case.

9.3 LTE BAND 5

QPSK EIRP POWER FOR LTE BAND 5 (1.4MHZ BANDWIDTH)

Test Results for Low Channel 824.7MHz							
Frequency(MHz)	SG Level(dBm)	Cable Loss(dB)	Antenna Gain(dB)	Absolute Level(dBm)	Limit (dBm)	Margin(dBm)	Polarity
1649.4	-44.73	2.78	27.50	-20.01	-13	-7.01	Horizontal
1649.4	-51.54	2.78	27.50	-26.82	-13	-13.82	Vertical
2474.1	-44.30	2.90	27.80	-19.40	-13	-6.40	Vertical
2474.1	-53.06	2.90	27.80	-28.16	-13	-15.16	Horizontal
204.646	-41.10	1.76	17.59	-25.27	-13	-12.27	Vertical
346.133	-40.26	1.63	15.87	-26.02	-13	-13.02	Horizontal
Test Results For Mid Channel 836.5MHz							
1673.0	-47.98	2.80	27.48	-23.30	-13	-10.30	Horizontal
1673.0	-44.85	2.80	27.48	-20.17	-13	-7.17	Vertical
2509.5	-47.61	2.91	27.70	-22.82	-13	-9.82	Vertical
2509.5	-53.70	2.91	27.70	-28.91	-13	-15.91	Horizontal
202.985	-37.33	1.61	15.68	-23.26	-13	-10.26	Vertical
403.44	-44.07	1.59	17.52	-28.15	-13	-15.15	Horizontal
Test Results for High Channel 848.3MHz							
1696.6	-48.49	2.82	27.43	-23.88	-13	-10.88	Horizontal
1696.6	-48.53	2.82	27.43	-23.92	-13	-10.92	Vertical
2544.9	-44.52	2.92	27.74	-19.70	-13	-6.70	Vertical
2544.9	-50.82	2.92	27.74	-26.00	-13	-13.00	Horizontal
190.873	-40.72	1.69	16.67	-25.73	-13	-12.73	Vertical
258.16	-44.29	1.70	17.18	-28.81	-13	-15.81	Horizontal

QPSK EIRP POWER FOR LTE BAND 5 (10MHZ BANDWIDTH)

Test Results for Low Channel 829MHz							
Frequency(MHz)	SG Level(dBm)	Cable Loss(dB)	Antenna Gain(dB)	Absolute Level(dBm)	Limit (dBm)	Margin(dBm)	Polarity
1658.0	-46.11	2.78	27.50	-21.39	-13	-8.39	Horizontal
1658.0	-53.33	2.78	27.50	-28.61	-13	-15.61	Vertical
2487.0	-49.07	2.90	27.80	-24.17	-13	-11.17	Vertical
2487.0	-51.51	2.90	27.80	-26.61	-13	-13.61	Horizontal
188.241	-40.20	1.71	15.57	-26.34	-13	-13.34	Vertical
376.596	-42.10	1.34	16.40	-27.04	-13	-14.04	Horizontal
Test Results For Mid Channel 836.5MHz							
1673.0	-53.74	2.80	27.48	-29.06	-13	-16.06	Horizontal
1673.0	-50.09	2.80	27.48	-25.41	-13	-12.41	Vertical
2509.5	-48.35	2.91	27.70	-23.56	-13	-10.56	Vertical
2509.5	-49.83	2.91	27.70	-25.04	-13	-12.04	Horizontal
192.798	-34.18	1.44	17.04	-18.58	-13	-5.58	Vertical
434.908	-35.47	1.76	17.62	-19.61	-13	-6.61	Horizontal
Test Results for High Channel 844MHz							
1688.0	-53.05	2.82	27.43	-28.44	-13	-15.44	Horizontal
1688.0	-44.83	2.82	27.43	-20.22	-13	-7.22	Vertical
2532.0	-45.18	2.92	27.74	-20.36	-13	-7.36	Vertical
2532.0	-53.27	2.92	27.74	-28.45	-13	-15.45	Horizontal
203.669	-43.63	1.74	17.70	-27.67	-13	-14.67	Vertical
409.533	-43.92	1.41	17.46	-27.86	-13	-14.86	Horizontal

Note: P_{Mea}(dBm)= Power(dBm)+ ARpl (dBm)

. Over Limit= : P_{Mea}(dBm)-Limit(dBm)

. Both QPSK and 16QAM has been tested, the worst case is QPSK mode, the report just reported the worst case.

9.4 LTE BAND 7

QPSK EIRP POWER FOR LTE BAND 7 (5.0MHZ BANDWIDTH)

Test Results for Low Channel 2502.5MHz							
Frequency(MHz)	SG Level(dBm)	Cable Loss(dB)	Antenna Gain(dB)	Absolute Level(dBm)	Limit (dBm)	Margin(dBm)	Polarity
5005.0	-62.97	5.23	35.81	-32.39	-25	-7.39	Horizontal
5005.0	-60.94	5.23	35.81	-30.36	-25	-5.36	Vertical
7507.5	-59.42	5.67	36.85	-28.24	-25	-3.24	Vertical
7507.5	-62.25	5.67	36.85	-31.07	-25	-6.07	Horizontal
213.6	-47.09	1.73	17.97	-30.85	-25	-5.85	Vertical
319.6	-46.15	1.38	15.11	-32.42	-25	-7.42	Horizontal
Test Results for Mid Channel 2535MHz							
5070.0	-62.94	5.23	35.82	-32.35	-25	-7.35	Horizontal
5070.0	-64.18	5.23	35.82	-33.59	-25	-8.59	Vertical
7605.0	-60.18	5.67	36.85	-29.00	-25	-4.00	Vertical
7605.0	-60.19	5.67	36.85	-29.01	-25	-4.01	Horizontal
269.3	-51.91	1.77	16.17	-37.50	-25	-12.50	Vertical
544.9	-48.79	1.63	15.21	-35.21	-25	-10.21	Horizontal
Test Results for High Channel 2567.5MHz							
5135.0	-62.27	5.24	35.83	-31.68	-25	-6.68	Horizontal
5135.0	-60.50	5.24	35.83	-29.91	-25	-4.91	Vertical
7702.5	-59.57	5.68	36.87	-28.38	-25	-3.38	Vertical
7702.5	-61.32	5.68	36.87	-30.13	-25	-5.13	Horizontal
409.3	-45.17	1.58	17.56	-29.19	-25	-4.19	Vertical
563.5	-52.67	1.45	16.58	-37.54	-25	-12.54	Horizontal

QPSK EIRP POWER FOR LTE BAND 7 (20.0MHZ BANDWIDTH)

Test Results for Low Channel 2510MHz							
Frequency(MHz)	SG Level(dBm)	Cable Loss(dB)	Antenna Gain(dB)	Absolute Level(dBm)	Limit (dBm)	Margin(dBm)	Polarity
5020.0	-59.01	5.23	35.82	-28.42	-25	-3.42	Horizontal
5020.0	-60.86	5.23	35.82	-30.27	-25	-5.27	Vertical
7530.0	-63.83	5.67	36.86	-32.64	-25	-7.64	Vertical
7530.0	-64.39	5.67	36.86	-33.20	-25	-8.20	Horizontal
469.9	-46.70	1.63	15.76	-32.57	-25	-7.57	Vertical
271.7	-52.17	1.71	15.44	-38.44	-25	-13.44	Horizontal
Test Results for Mid Channel 2535MHz							
5070.0	-63.71	5.23	35.82	-33.12	-25	-8.12	Horizontal
5070.0	-63.69	5.23	35.82	-33.10	-25	-8.10	Vertical
7605.0	-61.18	5.67	36.85	-30.00	-25	-5.00	Vertical
7605.0	-63.29	5.67	36.85	-32.11	-25	-7.11	Horizontal
357.3	-53.55	1.79	16.84	-38.49	-25	-13.49	Vertical
442.2	-51.78	1.71	17.64	-35.85	-25	-10.85	Horizontal
Test Results for High Channel 2560MHz							
5120.0	-61.09	5.24	35.83	-30.50	-25	-5.50	Horizontal
5120.0	-59.55	5.24	35.83	-28.96	-25	-3.96	Vertical
7680.0	-64.96	5.70	36.88	-33.78	-25	-8.78	Vertical
7680.0	-62.19	5.70	36.88	-31.01	-25	-6.01	Horizontal
345.9	-44.33	1.79	16.84	-29.27	-25	-4.27	Vertical
486.2	-45.86	1.71	17.64	-29.93	-25	-4.93	Horizontal

Note: P_{Mea}(dBm)= Power(dBm)+ ARpl (dBm)

Over Limit= : P_{Mea}(dBm)-Limit(dBm)

Both QPSK and 16QAM has been tested, the worst case is QPSK mode, the report just reported the worst case.

9.5 LTE BAND 17

QPSK EIRP POWER FOR LTE BAND 17 (5MHZ BANDWIDTH)

Test Results for Low Channel 706.5MHz							
Frequency(MHz)	SG Level(dBm)	Cable Loss(dB)	Antenna Gain(dB)	Absolute Level(dBm)	Limit (dBm)	Margin(dBm)	Polarity
1413.0	-47.39	2.61	27.28	-22.72	-13	-9.72	Horizontal
1413.0	-48.89	2.61	27.28	-24.22	-13	-11.22	Vertical
2119.5	-47.56	2.87	27.59	-22.84	-13	-9.84	Vertical
2119.5	-52.67	2.87	27.59	-27.95	-13	-14.95	Horizontal
195.506	-41.00	1.71	16.15	-26.56	-13	-13.56	Vertical
380.019	-39.00	1.41	17.32	-23.09	-13	-10.09	Horizontal
Test Results For Mid Channel 710MHz							
1420.0	-53.41	2.62	27.30	-28.73	-13	-15.73	Horizontal
1420.0	-48.05	2.62	27.30	-23.37	-13	-10.37	Vertical
2130.0	-52.57	2.87	27.62	-27.82	-13	-14.82	Vertical
2130.0	-49.06	2.87	27.62	-24.31	-13	-11.31	Horizontal
181.378	-42.63	1.42	15.25	-28.81	-13	-15.81	Vertical
323.031	-40.33	1.36	17.19	-24.50	-13	-11.50	Horizontal
Test Results for High Channel 713.5MHz							
1427.0	-51.12	2.66	27.28	-26.50	-13	-13.50	Horizontal
1427.0	-49.73	2.66	27.28	-25.11	-13	-12.11	Vertical
2140.5	-46.79	2.88	27.60	-22.07	-13	-9.07	Vertical
2140.5	-52.69	2.88	27.60	-27.97	-13	-14.97	Horizontal
210.742	-41.27	1.32	17.29	-25.30	-13	-12.30	Vertical
238.037	-38.62	1.72	16.89	-23.45	-13	-10.45	Horizontal

QPSK EIRP POWER FOR LTE BAND 17 (10MHZ BANDWIDTH)

Test Results for Low Channel 709MHz							
Frequency(MHz)	SG Level(dBm)	Cable Loss(dB)	Antenna Gain(dB)	Absolute Level(dBm)	Limit (dBm)	Margin(dBm)	Polarity
1418.0	-50.20	2.62	27.30	-25.52	-13	-12.52	Horizontal
1418.0	-48.48	2.62	27.30	-23.80	-13	-10.80	Vertical
2127.0	-46.60	2.87	27.62	-21.85	-13	-8.85	Vertical
2127.0	-50.36	2.87	27.62	-25.61	-13	-12.61	Horizontal
212.385	-38.91	1.35	16.91	-23.35	-13	-10.35	Vertical
340.107	-34.52	1.62	16.31	-19.83	-13	-6.83	Horizontal
Test Results for Mid Channel 710MHz							
1420.0	-46.26	2.62	27.30	-21.58	-13	-8.58	Horizontal
1420.0	-47.73	2.62	27.30	-23.05	-13	-10.05	Vertical
2130.0	-46.82	2.87	27.62	-22.07	-13	-9.07	Vertical
2130.0	-51.02	2.87	27.62	-26.27	-13	-13.27	Horizontal
205.852	-38.30	1.51	17.14	-22.67	-13	-9.67	Vertical
363.86	-42.43	1.77	16.88	-27.32	-13	-14.32	Horizontal
Test Results for High Channel 711MHz							
1422.0	-46.75	2.62	27.30	-22.07	-13	-9.07	Horizontal
1422.0	-50.74	2.62	27.30	-26.06	-13	-13.06	Vertical
2133.0	-52.73	2.87	27.62	-27.98	-13	-14.98	Vertical
2133.0	-50.86	2.87	27.62	-26.11	-13	-13.11	Horizontal
176.105	-36.68	1.78	15.95	-22.51	-13	-9.51	Vertical
400.71	-36.37	1.34	17.95	-19.77	-13	-6.77	Horizontal

Note: P_{Mea}(dBm)= Power(dBm)+ AR_{pl} (dBm)

. Over Limit= : P_{Mea}(dBm)-Limit(dBm)

. Both QPSK and 16QAM has been tested, the worst case is QPSK mode, the report just reported the worst case.

9.6 LTE BAND 66

QPSK EIRP POWER FOR LTE BAND 66 (1.4MHZ BANDWIDTH)

Test Results for Low Channel 1710.7MHz							
Frequency(MHz)	SG Level(dBm)	Cable Loss(dB)	Antenna Gain(dB)	Absolute Level(dBm)	Limit (dBm)	Margin(dBm)	Polarity
1413	-50.99	2.61	27.28	-26.32	-13	-13.32	Horizontal
1413	-52.88	2.61	27.28	-28.21	-13	-15.21	Vertical
2119.5	-52.29	2.87	27.59	-27.57	-13	-14.57	Vertical
2119.5	-46.03	2.87	27.59	-21.31	-13	-8.31	Horizontal
Test Results For Mid Channel 1745MHz							
1420	-47.51	2.62	27.3	-22.83	-13	-9.83	Horizontal
1420	-53.24	2.62	27.3	-28.56	-13	-15.56	Vertical
2130	-50.05	2.87	27.62	-25.30	-13	-12.30	Vertical
2130	-53.04	2.87	27.62	-28.29	-13	-15.29	Horizontal
Test Results for High Channel 1779.3MHz							
1427	-51.75	2.66	27.28	-27.13	-13	-14.13	Horizontal
1427	-48.18	2.66	27.28	-23.56	-13	-10.56	Vertical
2140.5	-45.80	2.88	27.6	-21.08	-13	-8.08	Vertical
2140.5	-51.40	2.88	27.6	-26.68	-13	-13.68	Horizontal

QPSK EIRP POWER FOR LTE BAND 66 (20MHZ BANDWIDTH)

Test Results for Low Channel 1720MHz							
Frequency(MHz)	SG Level(dBm)	Cable Loss(dB)	Antenna Gain(dB)	Absolute Level(dBm)	Limit (dBm)	Margin(dBm)	Polarity
1418	-44.11	2.62	27.3	-19.43	-13	-6.43	Horizontal
1418	-51.45	2.62	27.3	-26.77	-13	-13.77	Vertical
2127	-48.84	2.87	27.62	-24.09	-13	-11.09	Vertical
2127	-49.14	2.87	27.62	-24.39	-13	-11.39	Horizontal
Test Results for Mid Channel 1745MHz							
1420	-45.98	2.62	27.3	-21.30	-13	-8.30	Horizontal
1420	-44.84	2.62	27.3	-20.16	-13	-7.16	Vertical
2130	-46.83	2.87	27.62	-22.08	-13	-9.08	Vertical
2130	-50.77	2.87	27.62	-26.02	-13	-13.02	Horizontal
Test Results for High Channel 1770MHz							
1422	-50.95	2.62	27.3	-26.27	-13	-13.27	Horizontal
1422	-53.71	2.62	27.3	-29.03	-13	-16.03	Vertical
2133	-53.99	2.87	27.62	-29.24	-13	-16.24	Vertical
2133	-45.58	2.87	27.62	-20.83	-13	-7.83	Horizontal

Note: P_{Mea}(dBm)= Power(dBm)+ ARpl (dBm)

Over Limit= : P_{Mea}(dBm)-Limit(dBm)

We test both H direction and V direction, recorded worst case direction.

10. FREQUENCY STABILITY

RULE PART(S)

FCC: §2.1055, §22.355, §24.235, §27.54

LIMITS

§22.355 - The carrier frequency shall not depart from the reference frequency in excess of ± 2.5 ppm for mobile stations.

§24.235 - The frequency stability shall be sufficient to ensure that the fundamental emission stays within the authorized frequency block.

TEST PROCEDURE

Use CMW 500 with Frequency Error measurement capability.

Temp. = -30° to $+50^{\circ}$ C

Voltage = low voltage, DC 3.4V, Normal, DC 3.85V and High voltage, DC 4.2V.

Frequency Stability vs Temperature:

The EUT is placed inside a temperature chamber. The temperature is set to -30° C and allowed to stabilize. After sufficient soak time, the transmitting frequency error is measured. The temperature is increased by 10 degrees, allowed to stabilize and soak, and then the measurement is repeated. This is repeated until $+50^{\circ}$ C is reached.

Frequency Stability vs Voltage:

The peak frequency error is recorded (worst-case).

MODES TESTED

LTE Band 2
LTE Band 4
LTE Band 5
LTE Band 7
LTE Band 17
LTE Band 66

RESULTS

See the following pages.

10.1 LTE BAND 2

QPSK, (20MHz BANDWIDTH)

Frequency error vs. Voltage

Voltage [Vdc]	Frequency [MHz]	Frequency* Error[Hz]	Frequency Error[ppm]	Limit [ppm]
BAND 2 QPSK, (CH 18900 RB size 100 RB Offset 0 20MHz BANDWIDTH)				
3.4	1880	12.5	0.006624	2.5
3.85	1880	14.2	0.007561	2.5
4.4	1880	13.3	0.007060	2.5

Frequency error vs. Temperature

Temperature [° C]	Frequency [MHz]	Frequency* Error[Hz]	Frequency Error[ppm]	Limit [ppm]
BAND 2 QPSK, (CH 18900 RB size 100 RB Offset 0 20MHz BANDWIDTH)				
Normal (25C)	1880	12.4	0.006593	2.5
Extreme (50C)	1880	11.7	0.006248	2.5
Extreme (40C)	1880	13.7	0.007281	2.5
Extreme (30C)	1880	13.7	0.007272	2.5
Extreme (10C)	1880	13.7	0.007270	2.5
Extreme (0C)	1880	11.8	0.006302	2.5
Extreme (-10C)	1880	13.1	0.006980	2.5
Extreme (-20C)	1880	13.7	0.007261	2.5
Extreme (-30C)	1880	15.1	0.008007	2.5

16QAM, (20MHz BANDWIDTH)

Frequency error vs. Voltage

Voltage [Vdc]	Frequency [MHz]	Frequency* Error[Hz]	Frequency Error[ppm]	Limit [ppm]
BAND 2 16QAM, (CH 18900 RB size 100 RB Offset 0 20MHz BANDWIDTH)				
3.4	1880	9.7	0.005134	2.5
3.85	1880	8.5	0.004496	2.5
4.4	1880	7.8	0.004171	2.5

Frequency error vs. Temperature

Temperature [° C]	Frequency [MHz]	Frequency* Error[Hz]	Frequency Error[ppm]	Limit [ppm]
BAND 2 16QAM, (CH 18900 RB size 100 RB Offset 0 20MHz BANDWIDTH)				
Normal (25C)	1880	9.5	0.005071	2.5
Extreme (50C)	1880	8.4	0.004484	2.5
Extreme (40C)	1880	7.7	0.004081	2.5
Extreme (30C)	1880	8.7	0.004613	2.5
Extreme (10C)	1880	9.2	0.004913	2.5
Extreme (0C)	1880	8.4	0.004464	2.5
Extreme (-10C)	1880	9.1	0.004839	2.5
Extreme (-20C)	1880	8.9	0.004746	2.5
Extreme (-30C)	1880	8.3	0.004390	2.5

*Note: Frequency error measurements were made by using the build-in capability of the Wireless Communication Test Set.

10.2 LTE BAND 4

QPSK, (10MHz BANDWIDTH)

Frequency error vs. Voltage

Voltage [Vdc]	Frequency [MHz]	Frequency* Error[Hz]	Frequency Error[ppm]	Limit [ppm]
BAND 4 QPSK, (CH 20175 RB size 100 RB Offset 0 20MHz BANDWIDTH)				
3.4	1732.5	9.0	0.005178	2.5
3.85	1732.5	9.3	0.005396	2.5
4.4	1732.5	8.5	0.004898	2.5

Frequency error vs. Temperature

Temperature [°C]	Frequency [MHz]	Frequency* Error[Hz]	Frequency Error[ppm]	Limit [ppm]
BAND 4 QPSK, (CH 20175 RB size 100 RB Offset 0 20MHz BANDWIDTH)				
Normal (25C)	1732.5	8.4	0.004867	2.5
Extreme (50C)	1732.5	8.6	0.004961	2.5
Extreme (40C)	1732.5	7.5	0.004319	2.5
Extreme (30C)	1732.5	5.6	0.003209	2.5
Extreme (10C)	1732.5	7.1	0.004127	2.5
Extreme (0C)	1732.5	9.1	0.005274	2.5
Extreme (-10C)	1732.5	8.3	0.004767	2.5
Extreme (-20C)	1732.5	6.4	0.003707	2.5
Extreme (-30C)	1732.5	8.0	0.004624	2.5

16QAM, (20MHz BANDWIDTH)

Frequency error vs. Voltage

Voltage [Vdc]	Frequency [MHz]	Frequency* Error[Hz]	Frequency Error[ppm]	Limit [ppm]
BAND 4 16QAM, (CH 20175 RB size 100 RB Offset 0 20MHz BANDWIDTH)				
3.4	1732.5	9.9	0.005734	2.5
3.85	1732.5	9.3	0.005365	2.5
4.4	1732.5	8.5	0.004898	2.5

Frequency error vs. Temperature

Temperature [°C]	Frequency [MHz]	Frequency* Error[Hz]	Frequency Error[ppm]	Limit [ppm]
BAND 4 16QAM, (CH 20175 RB size 100 RB Offset 0 20MHz BANDWIDTH)				
Normal (25C)	1732.5	9.4	0.005434	2.5
Extreme (50C)	1732.5	9.4	0.005404	2.5
Extreme (40C)	1732.5	8.0	0.004628	2.5
Extreme (30C)	1732.5	8.9	0.005154	2.5
Extreme (10C)	1732.5	8.6	0.004991	2.5
Extreme (0C)	1732.5	7.8	0.004482	2.5
Extreme (-10C)	1732.5	8.7	0.005046	2.5
Extreme (-20C)	1732.5	9.0	0.005220	2.5
Extreme (-30C)	1732.5	8.4	0.004842	2.5

***Note:** Frequency error measurements were made by using the build-in capability of the Wireless Communication Test Set.

10.3 LTE BAND 5

QPSK, (10MHz BANDWIDTH)

Frequency error vs. Voltage

Voltage [Vdc]	Frequency [MHz]	Frequency* Error[Hz]	Frequency Error[ppm]	Limit [ppm]
BAND 5 QPSK, (CH 20525 RB size 50 RB Offset 0 10MHz BANDWIDTH)				
3.4	836.5	5.5	0.006620	2.5
3.85	836.5	6.8	0.008122	2.5
4.4	836.5	4.7	0.005636	2.5

Frequency error vs. Temperature

Temperature [° C]	Frequency [MHz]	Frequency* Error[Hz]	Frequency Error[ppm]	Limit [ppm]
BAND 5 QPSK, (CH 20525 RB size 50 RB Offset 0 10MHz BANDWIDTH)				
Normal (25C)	836.5	6.4	0.007643	2.5
Extreme (50C)	836.5	5.7	0.006859	2.5
Extreme (40C)	836.5	6.0	0.007217	2.5
Extreme (30C)	836.5	5.9	0.007062	2.5
Extreme (10C)	836.5	5.9	0.007028	2.5
Extreme (0C)	836.5	5.0	0.005935	2.5
Extreme (-10C)	836.5	5.6	0.006749	2.5
Extreme (-20C)	836.5	6.1	0.007259	2.5
Extreme (-30C)	836.5	6.5	0.007714	2.5

16QAM, (10MHz BANDWIDTH)

Frequency error vs. Voltage

Voltage [Vdc]	Frequency [MHz]	Frequency* Error[Hz]	Frequency Error[ppm]	Limit [ppm]
BAND 5 16QAM, (CH 20525 RB size 50 RB Offset 0 10MHz BANDWIDTH)				
3.4	836.5	6.1	0.007260	2.5
3.85	836.5	6.7	0.008005	2.5
4.4	836.5	5.3	0.006288	2.5

Frequency error vs. Temperature

Temperature [° C]	Frequency [MHz]	Frequency* Error[Hz]	Frequency Error[ppm]	Limit [ppm]
BAND 5 16QAM, (CH 20525 RB size 50 RB Offset 0 10MHz BANDWIDTH)				
Normal (25C)	836.5	6.1	0.007313	2.5
Extreme (50C)	836.5	5.8	0.006875	2.5
Extreme (40C)	836.5	5.7	0.006805	2.5
Extreme (30C)	836.5	6.2	0.007466	2.5
Extreme (10C)	836.5	5.0	0.005945	2.5
Extreme (0C)	836.5	5.6	0.006647	2.5
Extreme (-10C)	836.5	5.5	0.006563	2.5
Extreme (-20C)	836.5	6.1	0.007301	2.5
Extreme (-30C)	836.5	6.4	0.007598	2.5

***Note:** Frequency error measurements were made by using the build-in capability of the Wireless Communication Test Set.

10.4 LTE BAND 7

QPSK, (20MHz BANDWIDTH)

Frequency error vs. Voltage

Voltage [Vdc]	Frequency [MHz]	Frequency* Error[Hz]	Frequency Error[ppm]	Limit [ppm]
BAND 7 QPSK, (CH 21100 RB size 100 RB Offset 0 20MHz BANDWIDTH)				
3.4	2535	10.2	0.004034	2.5
3.85	2535	8.4	0.003321	2.5
4.4	2535	8.7	0.003444	2.5

Frequency error vs. Temperature

Temperature [° C]	Frequency [MHz]	Frequency* Error[Hz]	Frequency Error[ppm]	Limit [ppm]
BAND 7 QPSK, (CH 21100 RB size 100 RB Offset 0 20MHz BANDWIDTH)				
Normal (25C)	2535	9.0	0.003550	2.5
Extreme (50C)	2535	8.5	0.003358	2.5
Extreme (40C)	2535	8.6	0.003403	2.5
Extreme (30C)	2535	9.1	0.003583	2.5
Extreme (10C)	2535	7.8	0.003086	2.5
Extreme (0C)	2535	8.2	0.003216	2.5
Extreme (-10C)	2535	9.6	0.003806	2.5
Extreme (-20C)	2535	9.2	0.003623	2.5
Extreme (-30C)	2535	8.1	0.003195	2.5

16QAM, (20MHz BANDWIDTH)

Frequency error vs. Voltage

Voltage [Vdc]	Frequency [MHz]	Frequency* Error[Hz]	Frequency Error[ppm]	Limit [ppm]
BAND 7 16QAM, (CH 21100 RB size 100 RB Offset 0 20MHz BANDWIDTH)				
3.4	2535	6.4	0.002536	2.5
3.85	2535	6.9	0.002704	2.5
4.4	2535	5.5	0.002176	2.5

Frequency error vs. Temperature

Temperature [° C]	Frequency [MHz]	Frequency* Error[Hz]	Frequency Error[ppm]	Limit [ppm]
BAND 7 16QAM, (CH 21100 RB size 100 RB Offset 0 20MHz BANDWIDTH)				
Normal (25C)	2535	6.9	0.002706	2.5
Extreme (50C)	2535	6.1	0.002397	2.5
Extreme (40C)	2535	5.4	0.002132	2.5
Extreme (30C)	2535	6.4	0.002506	2.5
Extreme (10C)	2535	5.6	0.002216	2.5
Extreme (0C)	2535	5.0	0.001968	2.5
Extreme (-10C)	2535	5.6	0.002225	2.5
Extreme (-20C)	2535	6.2	0.002456	2.5
Extreme (-30C)	2535	5.3	0.002077	2.5

***Note:** Frequency error measurements were made by using the build-in capability of the Wireless Communication Test Set.

10.5 LTE BAND 17

QPSK, (10MHz BANDWIDTH)

Frequency error vs. Voltage

Voltage [Vdc]	Frequency [MHz]	Frequency* Error[Hz]	Frequency Error[ppm]	Limit [ppm]
BAND 17 QPSK, (CH 23790 RB size 50 RB Offset 0 10MHz BANDWIDTH)				
3.4	710.0	10.1	0.014194	2.5
3.85	710.0	9.4	0.013179	2.5
4.4	710.0	7.9	0.011062	2.5

Frequency error vs. Temperature

Temperature [° C]	Frequency [MHz]	Frequency* Error[Hz]	Frequency Error[ppm]	Limit [ppm]
BAND 17 QPSK, (CH 23790 RB size 50 RB Offset 0 10MHz BANDWIDTH)				
Normal (25C)	710.0	9.2	0.012999	2.5
Extreme (50C)	710.0	8.6	0.012076	2.5
Extreme (40C)	710.0	8.0	0.011248	2.5
Extreme (30C)	710.0	9.0	0.012706	2.5
Extreme (10C)	710.0	8.9	0.012476	2.5
Extreme (0C)	710.0	8.3	0.011715	2.5
Extreme (-10C)	710.0	8.5	0.012006	2.5
Extreme (-20C)	710.0	9.3	0.013066	2.5
Extreme (-30C)	710.0	7.7	0.010869	2.5

16QAM, (10MHz BANDWIDTH)

Frequency error vs. Voltage

Voltage [Vdc]	Frequency [MHz]	Frequency* Error[Hz]	Frequency Error[ppm]	Limit [ppm]
BAND 17 16QAM, (CH 23790 RB size 50 RB Offset 0 10MHz BANDWIDTH)				
3.4	710.0	9.6	0.013536	2.5
3.85	710.0	9.2	0.013021	2.5
4.4	710.0	8.5	0.011980	2.5

Frequency error vs. Temperature

Temperature [° C]	Frequency [MHz]	Frequency* Error[Hz]	Frequency Error[ppm]	Limit [ppm]
BAND 17 QPSK, (CH 23790 RB size 50 RB Offset 0 10MHz BANDWIDTH)				
Normal (25C)	710.0	8.9	0.012559	2.5
Extreme (50C)	710.0	8.4	0.011837	2.5
Extreme (40C)	710.0	8.2	0.011508	2.5
Extreme (30C)	710.0	8.5	0.011938	2.5
Extreme (10C)	710.0	7.8	0.011048	2.5
Extreme (0C)	710.0	8.7	0.012222	2.5
Extreme (-10C)	710.0	9.4	0.013198	2.5
Extreme (-20C)	710.0	8.4	0.011846	2.5
Extreme (-30C)	710.0	8.5	0.012013	2.5

***Note:** Frequency error measurements were made by using the build-in capability of the Wireless Communication Test Set.

10.6 LTE BAND 66

QPSK, (20MHz BANDWIDTH)

Frequency error vs. Voltage

Voltage [Vdc]	Frequency [MHz]	Frequency* Error[Hz]	Frequency Error[ppm]	Limit [ppm]
BAND 66 QPSK, (CH 132322 RB size 100 RB Offset 0 20MHz BANDWIDTH)				
3.4	1745	6.4	0.003653	2.5
3.85	1745	6.9	0.003937	2.5
4.4	1745	7.4	0.004218	2.5

Frequency error vs. Temperature

Temperature [° C]	Frequency [MHz]	Frequency* Error[Hz]	Frequency Error[ppm]	Limit [ppm]
BAND 66 QPSK, (CH 132322 RB size 100 RB Offset 0 20MHz BANDWIDTH)				
Normal (25C)	1745	5.6	0.003211	2.5
Extreme (50C)	1745	7.3	0.004183	2.5
Extreme (40C)	1745	6.9	0.003939	2.5
Extreme (30C)	1745	6.6	0.003796	2.5
Extreme (10C)	1745	7.5	0.004296	2.5
Extreme (0C)	1745	6.9	0.003945	2.5
Extreme (-10C)	1745	5.8	0.003341	2.5
Extreme (-20C)	1745	6.2	0.003536	2.5
Extreme (-30C)	1745	5.6	0.003191	2.5

16QAM, (20MHz BANDWIDTH)

Frequency error vs. Voltage

Voltage [Vdc]	Frequency [MHz]	Frequency* Error[Hz]	Frequency Error[ppm]	Limit [ppm]
BAND 66 16QAM, (CH 132322 RB size 100 RB Offset 0 20MHz BANDWIDTH)				
3.4	1745	9.0	0.005132	2.5
3.85	1745	7.8	0.004466	2.5
4.4	1745	9.0	0.005162	2.5

Frequency error vs. Temperature

Temperature [° C]	Frequency [MHz]	Frequency* Error[Hz]	Frequency Error[ppm]	Limit [ppm]
BAND 66 QPSK, (CH 132322 RB size 100 RB Offset 0 20MHz BANDWIDTH)				
Normal (25C)	1745	9.0	0.005131	2.5
Extreme (50C)	1745	7.8	0.004490	2.5
Extreme (40C)	1745	8.9	0.005081	2.5
Extreme (30C)	1745	8.5	0.004857	2.5
Extreme (10C)	1745	8.7	0.004974	2.5
Extreme (0C)	1745	6.5	0.003705	2.5
Extreme (-10C)	1745	8.0	0.004597	2.5
Extreme (-20C)	1745	8.9	0.005123	2.5
Extreme (-30C)	1745	5.4	0.003079	2.5

***Note:** Frequency error measurements were made by using the build-in capability of the Wireless Communication Test Set.

11. Peak-to-Average Ratio

11.1 Description of the PAR Measurement

The peak-to-average ratio (PAR) of the transmission may not exceed 13 dB.

11.2 Measuring Instruments

See list of measuring instruments of this test report.

11.3 Test Procedures

1. The EUT was connected to Spectrum Analyzer and Base Station via power divider.
2. The RF output of EUT was connected to the spectrum analyzer by RF cable and attenuator. The path loss was compensated to the results for each measurement.
3. For GSM/EGPRS operating modes:
 - a. Set the RBW = 1MHz, VBW = 1MHz, Peak detector in spectrum analyzer.
 - b. Set EUT in maximum power output, and triggered the burst signal.
 - c. Measured respectively the Peak level and Mean level, and the deviation was recorded as Peak to Average Ratio.
4. For UMTS operating modes:
 - a. Set the CCDF (Complementary Cumulative Distribution Function) option in spectrum analyzer.
 - b. The highest RF powers were measured and recorded the maximum PAPR level associated with a probability of 0.1 %.

11.4 Test Setup

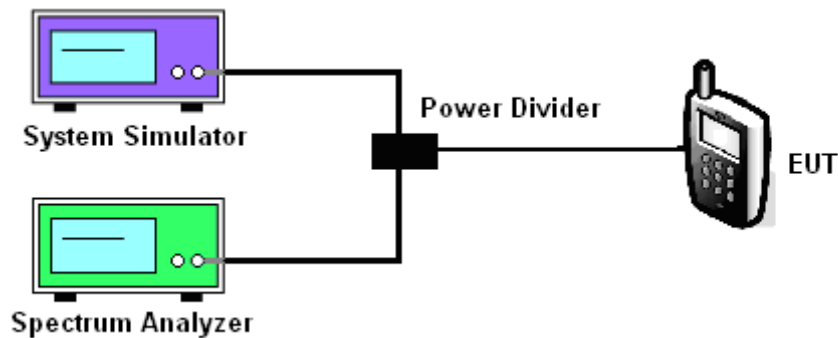

MODES TESTED

LTE Band 2/4/5/7/17/66

Test data reference attachment.

----END OF REPORT----