

# FCC Test Report

## FCC ID: 2AOWK-5008TF

**Product:** Mobile Phone  
**Trade Mark:** ulefone  
**Model Number:** GQ5008TF  
**Family Model:** Armor 27T, Armor 27, Armor 27 Ultra,  
Armor 27T Ultra, Armor 27 Lite, Armor  
27s, Armor 27s Pro  
**Report No.:** S24080806805008

**Prepared for**

Shenzhen Gotron Electronic CO.,LTD.  
7B01, Building A, Block 1, Anhongji Tianyao Plaza, Longhua District,  
Shenzhen City, Guangdong Province China

**Prepared by**

Shenzhen NTEK Testing Technology Co., Ltd.  
1/F, Building E, Fenda Science Park, Sanwei Community,  
Xixiang Street Bao'an District, Shenzhen P.R. China  
Tel. 400-800-6106, 0755-2320 0050, 0755-2320 0090  
Website:<http://www.ntek.org.cn>

TEST RESULT CERTIFICATION

Applicant's name.....: Shenzhen Gotron Electronic CO.,LTD.
Address.....: 7B01, Building A, Block 1, Anhongji Tianyao Plaza, Longhua District, Shenzhen City, Guangdong Province China
Manufacturer's Name.....: Shenzhen Gotron Electronic CO.,LTD.
Address.....: 7B01, Building A, Block 1, Anhongji Tianyao Plaza, Longhua District, Shenzhen City, Guangdong Province China

Product description

Product name.....: Mobile Phone
Model and/or type reference : GQ5008TF
Family Model.....: Armor 27T, Armor 27, Armor 27 Ultra, Armor 27T Ultra, Armor 27 Lite, Armor 27s, Armor 27s Pro

Standards .....: FCC Part15B
ANSI C63.4:2014

This device described above has been tested by NTEK, and the test results show that the equipment under test (EUT) is in compliance with Part 15 of FCC Rules. And it is applicable only to the tested sample identified in the report.

This report shall not be reproduced except in full, without the written approval of NTEK, this document may be altered or revised by NTEK, personnel only, and shall be noted in the revision of the document.

Test Sample Number.....: S240808068005
Date of Test .....:
Date (s) of performance of tests .....: Aug. 08, 2024 ~ Sept. 12, 2024
Date of Issue .....: Sept. 12, 2024
Test Result.....: Pass

Prepared By: Allen Liu (Project Engineer)

Reviewed By: Aaron Cheng (Supervisor)

Approved By: Alex Li (Manager)

**Table of Contents**

**Page**

<b>1 . TEST SUMMARY</b>	<b>4</b>
1.1 TEST FACILITY	5
1.2 MEASUREMENT UNCERTAINTY	5
<b>2 . GENERAL INFORMATION</b>	<b>6</b>
2.1 GENERAL DESCRIPTION OF EUT	6
2.2 DESCRIPTION OF TEST SETUP	8
2.3 DESCRIPTION TEST PERIPHERAL AND EUT PERIPHERAL	9
2.4 MEASUREMENT INSTRUMENTS LIST	10
<b>3 . EMC EMISSION TEST</b>	<b>11</b>
3.1 CONDUCTED EMISSION MEASUREMENT	11
3.1.1 POWER LINE CONDUCTED EMISSION	11
3.1.2 TEST PROCEDURE	12
3.1.3 TEST SETUP	12
3.1.4 EUT OPERATING CONDITIONS	12
3.1.5 TEST RESULTS	13
3.2 RADIATED EMISSION MEASUREMENT	15
3.2.1 LIMITS OF RADIATED EMISSION MEASUREMENT	15
3.2.2 TEST PROCEDURE	15
3.2.3 TEST SETUP	16
3.2.4 TEST RESULTS	17
3.2.5 TEST RESULTS(1000~18000MHz)	19

### 1. TEST SUMMARY

Test procedures according to the technical standards:

EMC Emission				
Standard	Test Item	Limit	Judgment	Remark
FCC Part15B ANSI C63.4: 2014	Conducted Emission	Class B	PASS	
	Radiated Emission	Class B	PASS	

NOTE:

- (1) 'N/A' denotes test is not applicable in this Test Report
- (2) For client's request and manual description, the test will not be executed.



## 2. GENERAL INFORMATION

### 2.1 GENERAL DESCRIPTION OF EUT

Equipment	Mobile Phone				
Trade Mark	ulefone				
Model Name	GQ5008TF				
Family Model	Armor 27T, Armor 27, Armor 27 Ultra, Armor 27T Ultra, Armor 27 Lite, Armor 27s, Armor 27s Pro				
Model Difference	All models are the same circuit and RF module, except for model names.				
Product Description	<table border="1"> <tr> <td>Connecting I/O port:</td> <td>Type-C USB, Earphone</td> </tr> <tr> <td>Operation Frequency:</td> <td>5.825GHz</td> </tr> </table>	Connecting I/O port:	Type-C USB, Earphone	Operation Frequency:	5.825GHz
	Connecting I/O port:	Type-C USB, Earphone			
Operation Frequency:	5.825GHz				
Based on the application, features, or specification exhibited in User's Manual, the EUT is considered as an ITE/Computing Device. More details of EUT technical specification, please refer to the User's Manual.					
Adapter	Model: UF82PD3303 Input: 100-240V~50/60Hz 0.8A Output: 5.0V ---3.0A 15.0W or 9.0V ---3.0A 27.0W or 12.0V ---2.5A 30.0W or 15.0V ---2.0A 30.0W or 20.0V ---1.5A 30.0W PPS: 5.0V-11.0V ---3.0A or 5.0V-16.0V ---2.0A 33.0W Max				
Battery	DC 3.87V, 10600mAh, 41.022Wh				
Power supply	DC 3.87V from battery or DC 5V/9V/12V/15V/20V from adapter				
HW Version	A300H_01				
SW Version	N/A				

### 2.1.1 DESCRIPTION OF TEST MODES

To investigate the maximum EMI emission characteristics generates from EUT, the test system was pre-scanning tested base on the consideration of following EUT operation mode or test configuration mode which possible have effect on EMI emission level. Each of these EUT operation mode(s) or test configuration mode(s) mentioned above was evaluated respectively.

Pretest Mode	Description
Model 1	USB Data Transmission
Model 2	TF card Playing
Model 3	REC
Model 4	FM
Model 5	GPS

For Conducted Test	
Final Test Mode	Description
Model 1	USB Data Transmission
Model 2	TF card Playing
Model 3	REC
Model 4	FM
Model 5	GPS

For Radiated Test	
Final Test Mode	Description
Model 1	USB Data Transmission
Model 2	TF card Playing
Model 3	REC
Model 4	FM
Model 5	GPS

Note: Final Test Mode: Through Pre-scan, find the model 1 is the worst case. Only the worst case mode is recorded in the report.

## 2.2 DESCRIPTION OF TEST SETUP

CE

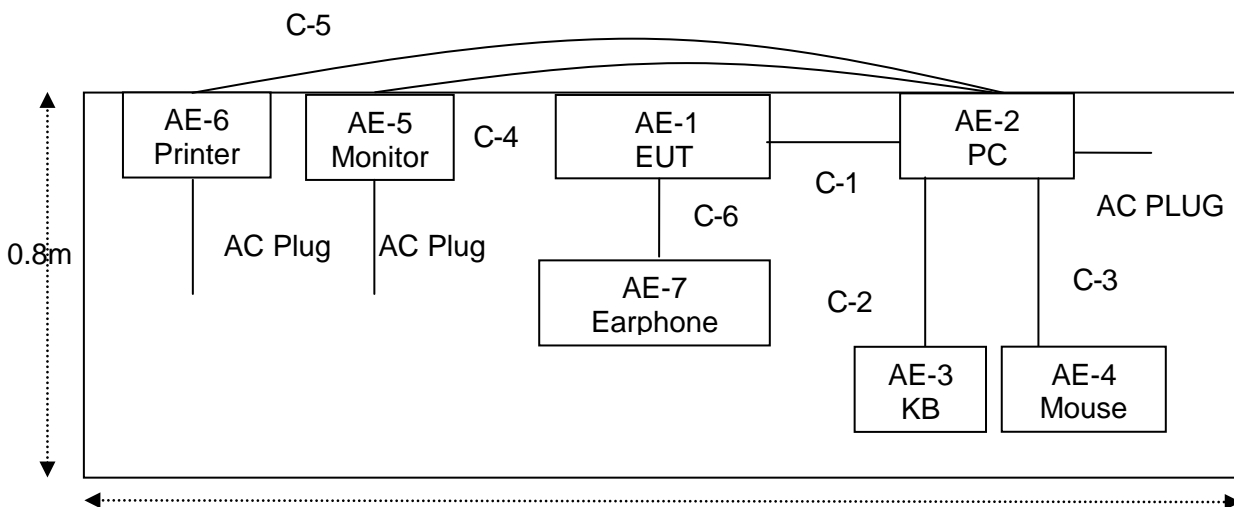

RE

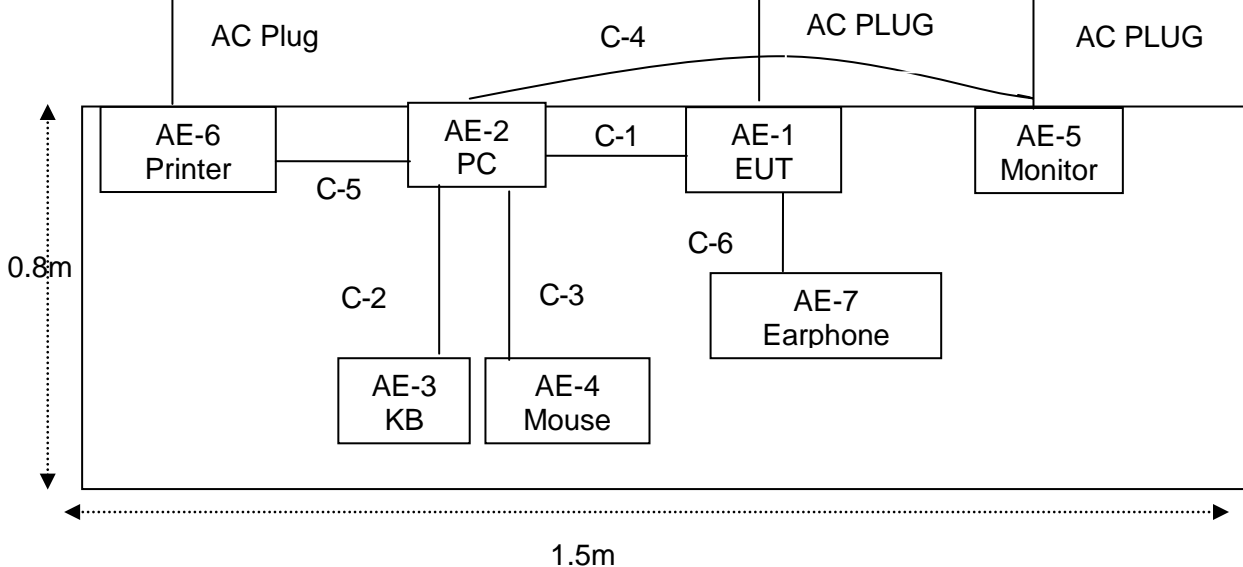



### 2.3 DESCRIPTION TEST PERIPHERAL AND EUT PERIPHERAL

The EUT has been tested as an independent unit together with other necessary accessories or support units. The following support units or accessories were used to form a representative test configuration during the tests.

Item	Equipment	Brand	Model/Type No.	Series No.	Note
AE-1	Mobile Phone	ulefone	GQ5008TF	N/A	EUT
AE-2	PC	DELL	FT4Y23X	N/A	Peripherals
AE-3	KB	N/A	N/A	N/A	Peripherals
AE-4	Mouse	N/A	N/A	N/A	Peripherals
AE-5	Monitor	N/A	N/A	N/A	Peripherals
AE-6	Printer	Canon	L11121E	N/A	Peripherals
AE-7	Earphone	N/A	N/A	N/A	Peripherals

Item	Cable Type	Shielded Type	Ferrite Core	Length	Note
C-1	USB Cable	NO	NO	1.0m	
C-2	USB Cable	NO	NO	1.2m	
C-3	USB Cable	NO	NO	1.2m	
C-4	HDMI Cable	YES	YES	1.0m	
C-5	USB Cable	NO	NO	1.2m	
C-6	Earphone Cable	NO	NO	1.5m	

**Note:**

- (1) The support equipment was authorized by Declaration of Confirmation.
- (2) For detachable type I/O cable should be specified the length in cm in 『Length』 column.
- (3) “YES” means “shielded” “with core”; “NO” means “unshielded” “without core”.

**2.4 MEASUREMENT INSTRUMENTS LIST**
**Radiation Test equipment**

Item	Kind of Equipment	Manufacturer	Type No.	Serial No.	Last calibration	Calibrated until	Calibration period
1	Spectrum Analyzer	Agilent	E4440A	MY41000130	2024.04.26	2025.04.25	1 year
2	Test Receiver	R&S	ESPI	101318	2024.04.26	2025.04.25	1 year
3	Bilog Antenna	TESEQ	CBL6111D	31216	2024.05.12	2025.05.11	1 year
4	50Ω Coaxial Switch	Anritsu	MP59B	6200264416	2024.03.12	2025.03.11	1 year
5	Spectrum Analyzer	ADVANTEST	R3132	150900201	2024.03.12	2025.03.11	1 year
6	Horn Antenna	EM	EM-AH-1018 0	2011071402	2024.05.12	2027.05.11	3 year
7	Horn Ant	Schwarzbeck	BBHA 9170	9170-181	2024.05.12	2027.05.11	3 year
8	Amplifier	EMC	EMC051835 SE	980246	2024.04.25	2025.04.24	1 year
9	Loop Antenna	ARA	PLA-1030/B	1029	2024.04.25	2025.04.24	1 year
10	Power Meter	DARE	RPR3006W	15100041SN O84	2024.04.25	2025.04.24	1 year
11	Power Sensor	R&S	URV4-Z4	0395.1619.0 5	2024.04.25	2025.04.24	1 year
12	Test Cable (30MHz-1GHz)	N/A	R-02	N/A	2023.05.06	2026.05.05	3 year
13	High Test Cable(1G-40G Hz)	N/A	R-03	N/A	2022.06.17	2025.06.16	3 year
14	High Test Cable(1G-40G Hz)	N/A	R-04	N/A	2023.05.06	2026.05.05	3 year
15	Test Receiver	R&S	ESCI	101160	2024.04.26	2025.04.25	1 year

**AC Conduction Test equipment**

Item	Kind of Equipment	Manufacturer	Type No.	Serial No.	Last calibration	Calibrated until	Calibration period
1	Test Receiver	R&S	ESCI	101160	2024.04.26	2025.04.25	1 year
2	LISN	R&S	ENV216	101313	2024.04.25	2025.04.24	1 year
3	LISN	SCHWARZBE CK	NNLK 8129	8129245	2024.04.25	2025.04.24	1 year
4	50Ω Coaxial Switch	ANRITSU CORP	MP59B	6200983704	2024.04.26	2027.04.25	3 year
5	Test Cable (9KHz-30MH z)	N/A	C01	N/A	2023.05.06	2026.05.05	3 year
6	Test Cable (9KHz-30MH z)	N/A	C02	N/A	2023.05.06	2026.05.05	3 year
7	Test Cable (9KHz-30MH z)	N/A	C03	N/A	2023.05.06	2026.05.05	3 year

Note: Each piece of equipment is scheduled for calibration once a year except the Test Cable which is scheduled for calibration every 3 years.

### 3. EMC EMISSION TEST

#### 3.1 CONDUCTED EMISSION MEASUREMENT

##### 3.1.1 POWER LINE CONDUCTED EMISSION (Frequency Range 150KHz-30MHz)

FREQUENCY (MHz)	Class A (dBuV)		Class B (dBuV)	
	Quasi-peak	Average	Quasi-peak	Average
0.15 -0.5	79.00	66.00	66 - 56 *	56 - 46 *
0.50 -5.0	73.00	60.00	56.00	46.00
5.0 -30.0	73.00	60.00	60.00	50.00

Note:

- (1) The tighter limit applies at the band edges.
- (2) The limit of " \* " marked band means the limitation decreases linearly with the logarithm of the frequency in the range.

The following table is the setting of the receiver

Receiver Parameters	Setting
Attenuation	10 dB
Start Frequency	0.15 MHz
Stop Frequency	30 MHz
IF Bandwidth	9 kHz

### 3.1.2 TEST PROCEDURE

- a. The EUT was placed 0.8 meters from the horizontal ground plane with EUT being connected to the power mains through a line impedance stabilization network (LISN). All other support equipments powered from additional LISN(s). The LISN provide 50 Ohm/ 50uH of coupling impedance for the measuring instrument.
- b. Interconnecting cables that hang closer than 40 cm to the ground plane shall be folded back and forth in the center forming a bundle 30 to 40 cm long.
- c. I/O cables that are not connected to a peripheral shall be bundled in the center. The end of the cable may be terminated, if required, using the correct terminating impedance. The overall length shall not exceed 1 m.
- d. LISN at least 80 cm from nearest part of EUT chassis.
- e. For the actual test configuration, please refer to the related Item –EUT Test Photos.

### 3.1.3 TEST SETUP

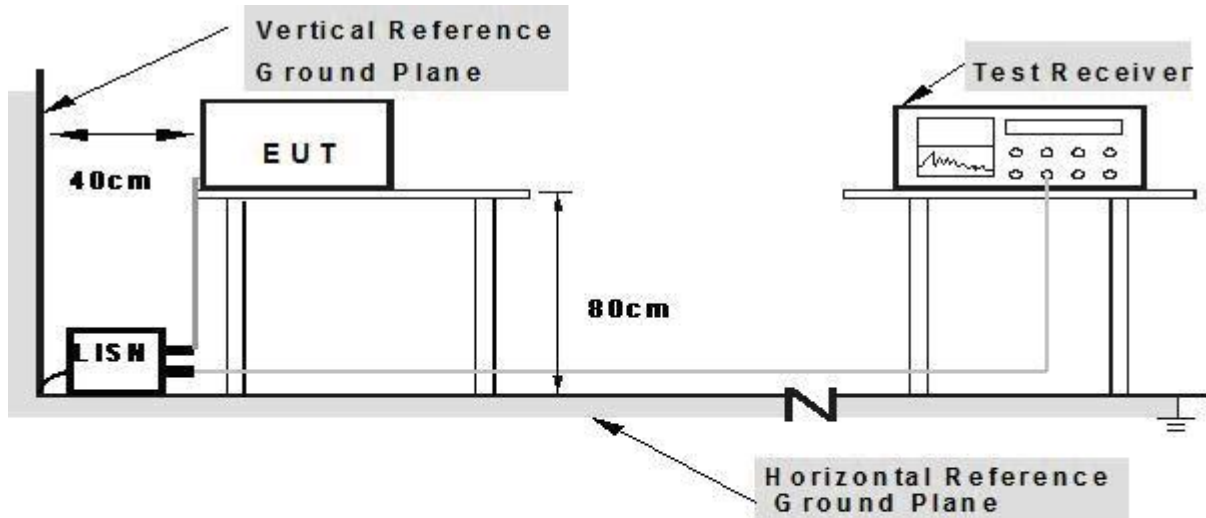

- Note: 1. Support units were connected to second LISN.**
- 2. Both of LISNs (AMN) are 80 cm from EUT and at least 80 cm from other units and other metal planes**

### 3.1.4 EUT OPERATING CONDITIONS

The EUT tested system was configured as the statements of **2.3** Unless otherwise a special operating condition is specified in the follows during the testing.

### 3.1.5 TEST RESULTS

EUT:	Mobile Phone	Model Name. :	GQ5008TF
Temperature:	24.5 °C	Relative Humidity:	52%
Pressure:	1010hPa	Test Date:	2024-08-14
Test Mode:	Mode 1	Phase :	L
Test Voltage:	DC 5V from PC AC 120V/60Hz		

Frequency (MHz)	Reading Level (dBμV)	Correct Factor (dB)	Measure-ment (dBμV)	Limits (dBμV)	Margin (dB)	Remark
0.1620	48.84	9.95	58.79	65.36	-6.57	QP
0.1620	27.03	9.95	36.98	55.36	-18.38	AVG
0.2460	37.17	10.14	47.31	61.89	-14.58	QP
0.2460	22.95	10.14	33.09	51.89	-18.80	AVG
0.3220	29.67	10.28	39.95	59.66	-19.71	QP
0.3220	13.78	10.28	24.06	49.66	-25.60	AVG
0.7980	25.10	11.26	36.36	56.00	-19.64	QP
0.7980	22.75	11.26	34.01	46.00	-11.99	AVG
1.8460	21.65	13.36	35.01	56.00	-20.99	QP
1.8460	7.36	13.36	20.72	46.00	-25.28	AVG
7.5620	31.47	9.68	41.15	60.00	-18.85	QP
7.5620	18.18	9.68	27.86	50.00	-22.14	AVG

Remark:

1. All readings are Quasi-Peak and Average values.
2. Factor = Insertion Loss + Cable Loss.

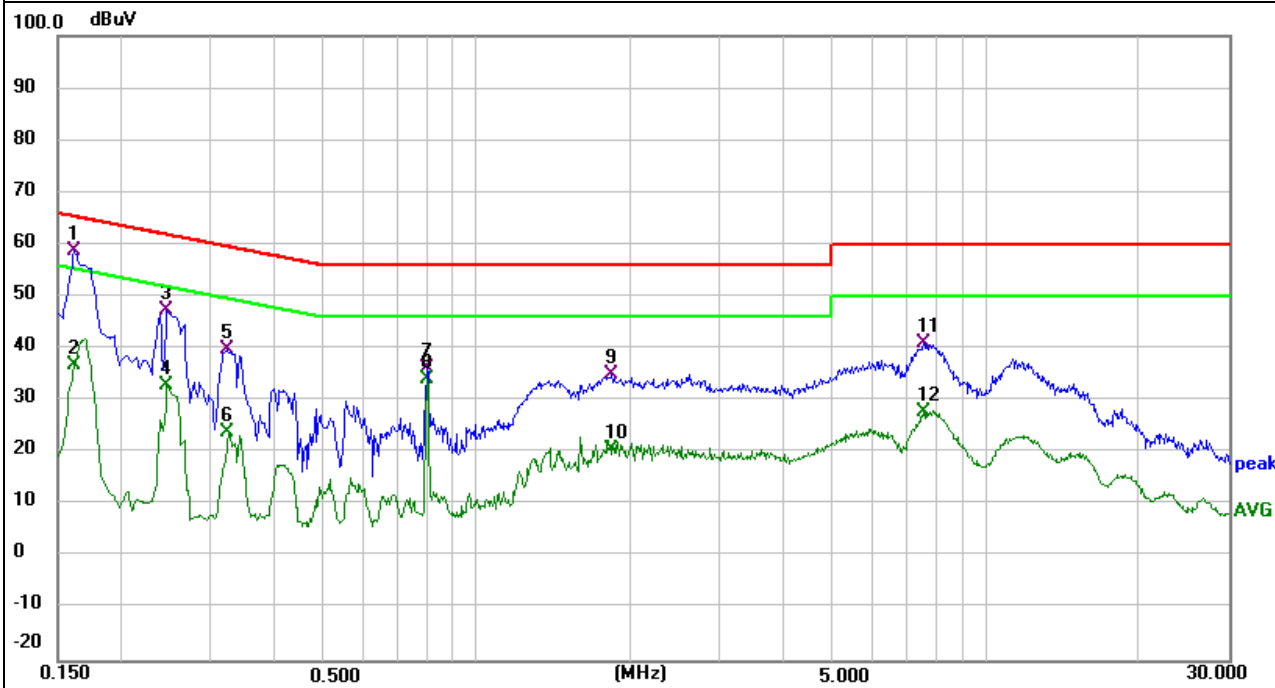

EUT:	Mobile Phone	Model Name. :	GQ5008TF
Temperature:	24.5 °C	Relative Humidity:	52%
Pressure:	1010hPa	Test Date:	2024-08-14
Test Mode:	Mode 1	Phase :	N
Test Voltage:	DC 5V from PC AC 120V/60Hz		

Frequency (MHz)	Reading Level (dBμV)	Correct Factor (dB)	Measurement (dBμV)	Limits (dBμV)	Margin (dB)	Remark
0.1620	48.72	9.95	58.67	65.36	-6.69	QP
0.1620	31.59	9.95	41.54	55.36	-13.82	AVG
0.2460	37.70	10.14	47.84	61.89	-14.05	QP
0.2460	19.73	10.14	29.87	51.89	-22.02	AVG
0.7980	26.89	11.26	38.15	56.00	-17.85	QP
0.7980	24.95	11.26	36.21	46.00	-9.79	AVG
1.5980	24.48	12.86	37.34	56.00	-18.66	QP
1.5980	14.75	12.86	27.61	46.00	-18.39	AVG
5.6180	26.81	9.68	36.49	60.00	-23.51	QP
5.6180	11.71	9.68	21.39	50.00	-28.61	AVG
11.2660	27.79	9.69	37.48	60.00	-22.52	QP
11.2660	12.89	9.69	22.58	50.00	-27.42	AVG

Remark:

1. All readings are Quasi-Peak and Average values.
2. Factor = Insertion Loss + Cable Loss.

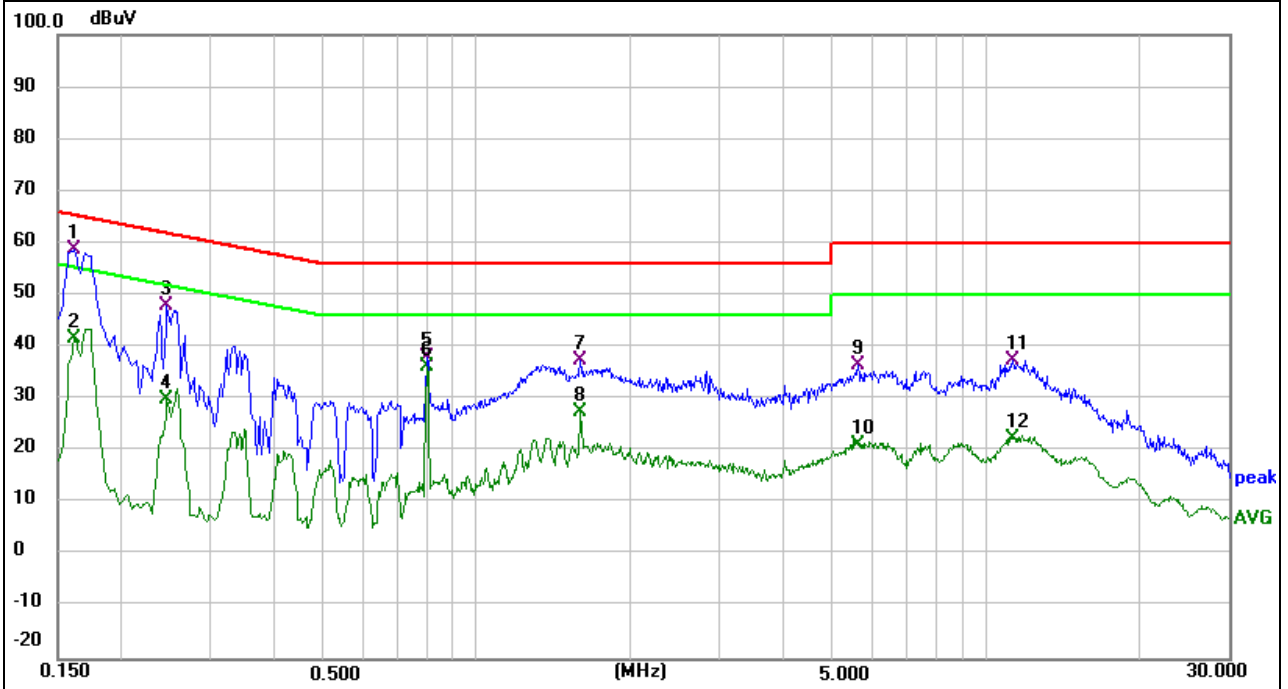

### 3.2 RADIATED EMISSION MEASUREMENT

#### 3.2.1 LIMITS OF RADIATED EMISSION MEASUREMENT

FREQUENCY (MHz)	Class A (at 10m)	Class B (at 3m)
	dBuV/m	dBuV/m
30 ~ 88	39.0	40.0
88 ~ 216	43.5	43.5
216 ~ 960	46.5	46.0
Above 960	49.5	54.0

Notes:

- (1) The limit for radiated test was performed according to as following:  
FCC PART 15B /ICES-003.
- (2) The tighter limit applies at the band edges.
- (3) Emission level (dBuV/m)=20log Emission level (uV/m).

#### 3.2.2 TEST PROCEDURE

##### Test Arrangement for Radiated Emissions up to 1 GHz

- a. The EUT was placed on the top of a rotating table 0.8 meters above the ground at an accredited test facility. The table was rotated 360 degrees to determine the position of the highest radiation.
- b. The EUT was set 3 meters away from the interference-receiving antenna, which was mounted on the top of a variable-height antenna tower.
- c. The antenna is a broadband antenna, and its height is varied from one meter to four meters above the ground to determine the maximum value of the field strength. Both horizontal and vertical polarizations of the antenna are set to make the measurement.
- d. For each suspected emission, the EUT was arranged to its worst case and then the antenna was tuned to heights from 1 meter to 4 meters and the rotatable table was turned from 0 degrees to 360 degrees to find the maximum reading.

Note: The resolution bandwidth and video bandwidth of test receiver/spectrum analyzer is 120kHz for quasi-peak detection (QP) at frequency below 1GHz.

##### Test Arrangement for Radiated Emissions above 1 GHz.

- a. The EUT was placed on the top of a rotating table 0.8 meters above the ground at an accredited chamber room. The table was rotated 360 degrees to determine the position of the highest radiation.
- b. The EUT was set 3 meters away from the interference-receiving antenna, which was mounted on the top of a variable-height antenna tower.
- c. The height of antenna can be varied from one meter to four meters, the height of adjustment depends on the EUT height and the antenna 3dB beamwidth both, to detect the maximum value of the field strength. Both horizontal and vertical polarizations of the antenna are set to make the measurement.
- d. For each suspected emission, the EUT was arranged to its worst case and then the antenna was tuned to heights and the rotatable table was turned from 0 degrees to 360 degrees to find the maximum reading.

Note: For the hand-held device, the EUT should be measured for all 3 axes and only the worst case is recorded in the report

During the radiated emission test, according to ANSI C63.4-2014(4.2), the Spectrum Analyzer was set with the following configurations:

Frequency Band (MHz)	Function	Resolution bandwidth	Video Bandwidth
30 to 1000	QP	120 kHz	300 kHz
Above 1000	Peak	1 MHz	3 MHz
	Avg	1 MHz	10 Hz

### 3.2.3 TEST SETUP

For Radiated Emission 30~1000MHz

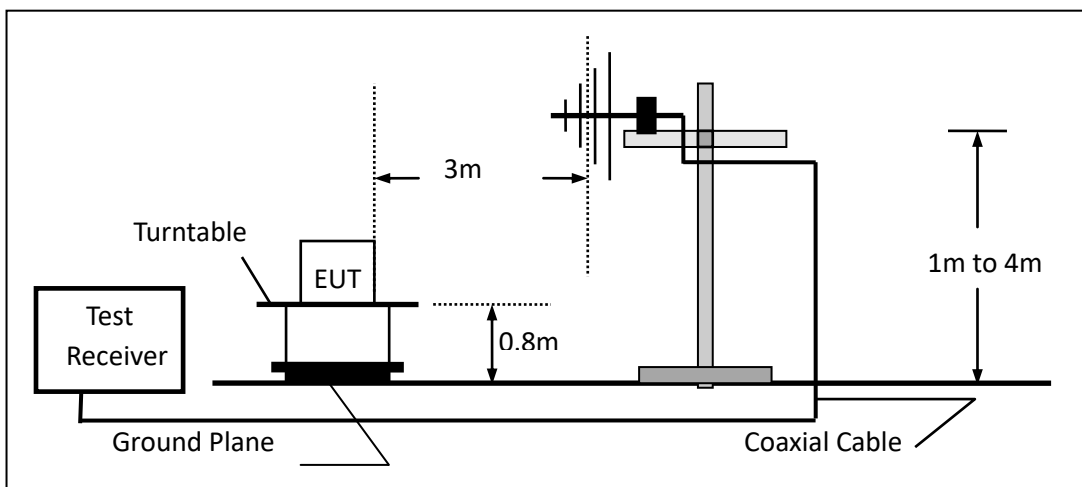

(B) Radiated Emission Test Set-Up Frequency Above 1GHz

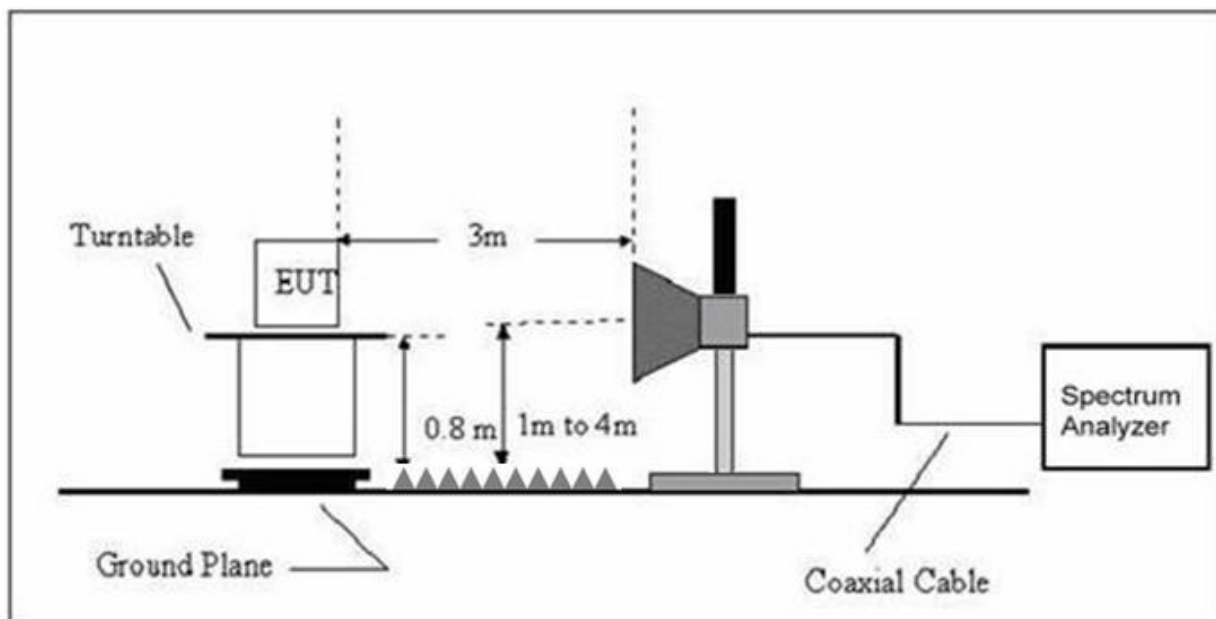



3.2.4 TEST RESULTS

TEST RESULTS (30~1000 MHz)

EUT:	Mobile Phone	Model Name:	GQ5008TF
Temperature:	24.5 °C	Relative Humidity:	55%
Pressure:	1010 hPa	Test Date :	2024-08-13
Test Mode :	Mode 1	Polarization :	Horizontal
Test Power :	DC 5V from PC AC 120V/60Hz		

Polar (H/V)	Frequency	Meter Reading	Factor	Emission Level	Limits	Margin	Remark
	(MHz)	(dBuV)	(dB)	(dBuV/m)	(dBuV/m)	(dB)	
H	84.7019	9.17	14.14	23.31	40.00	-16.69	QP
H	195.1365	8.02	17.46	25.48	43.50	-18.02	QP
H	284.9767	13.38	19.88	33.26	46.00	-12.74	QP
H	314.3765	14.77	20.51	35.28	46.00	-10.72	QP
H	558.7302	8.78	25.09	33.87	46.00	-12.13	QP
H	785.0935	6.72	28.83	35.55	46.00	-10.45	QP

Remark:

Factor = Antenna Factor + Cable Loss - Amplifier.

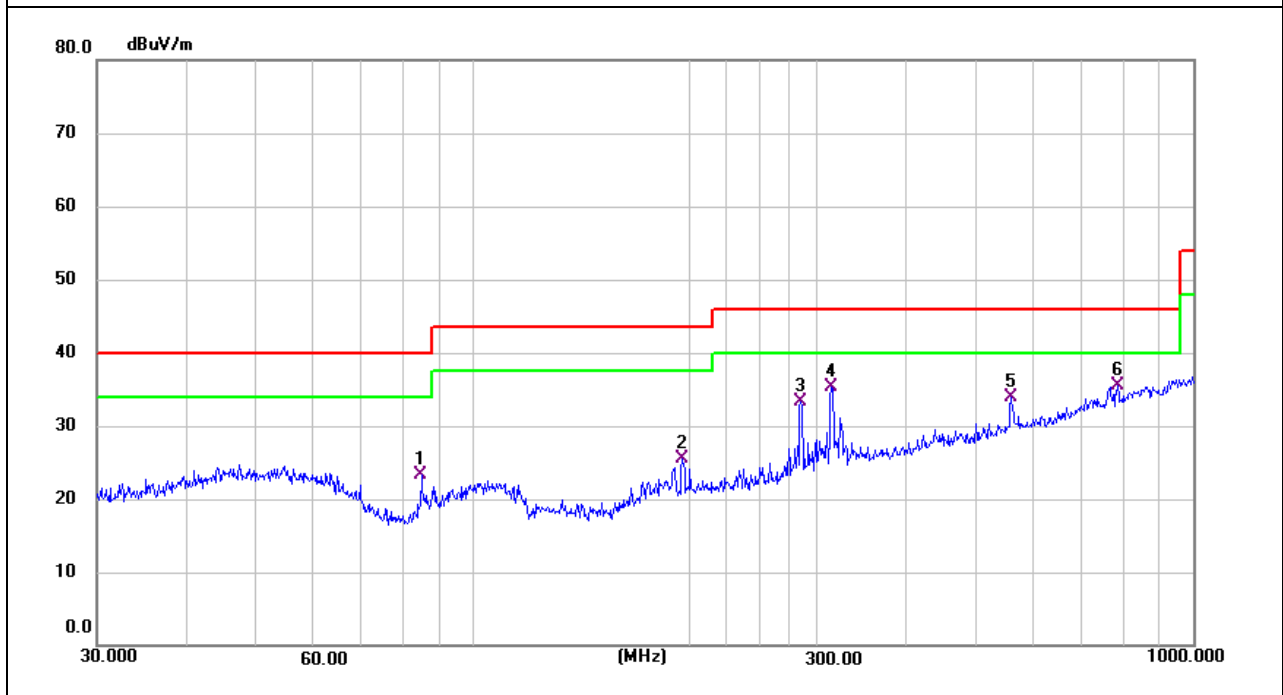

EUT:	Mobile Phone	Model Name :	GQ5008TF
Temperature:	24.5 °C	Relative Humidity:	55%
Pressure:	1010 hPa	Test Date :	2024-08-13
Test Mode :	Mode 1	Polarization :	Vertical
Test Power :	DC 5V from PC AC 120V/60Hz		

Polar (H/V)	Frequency	Meter Reading	Factor	Emission Level	Limits	Margin	Remark
	(MHz)	(dBuV)	(dB)	(dBuV/m)	(dBuV/m)	(dB)	
V	53.6932	5.07	19.37	24.44	40.00	-15.56	QP
V	141.3298	11.64	14.06	25.70	43.50	-17.80	QP
V	196.5098	8.75	17.49	26.24	43.50	-17.26	QP
V	314.3765	8.55	20.51	29.06	46.00	-16.94	QP
V	562.6624	9.69	25.18	34.87	46.00	-11.13	QP
V	763.3757	7.83	28.45	36.28	46.00	-9.72	QP

Remark:  
Factor = Antenna Factor + Cable Loss - Amplifier.

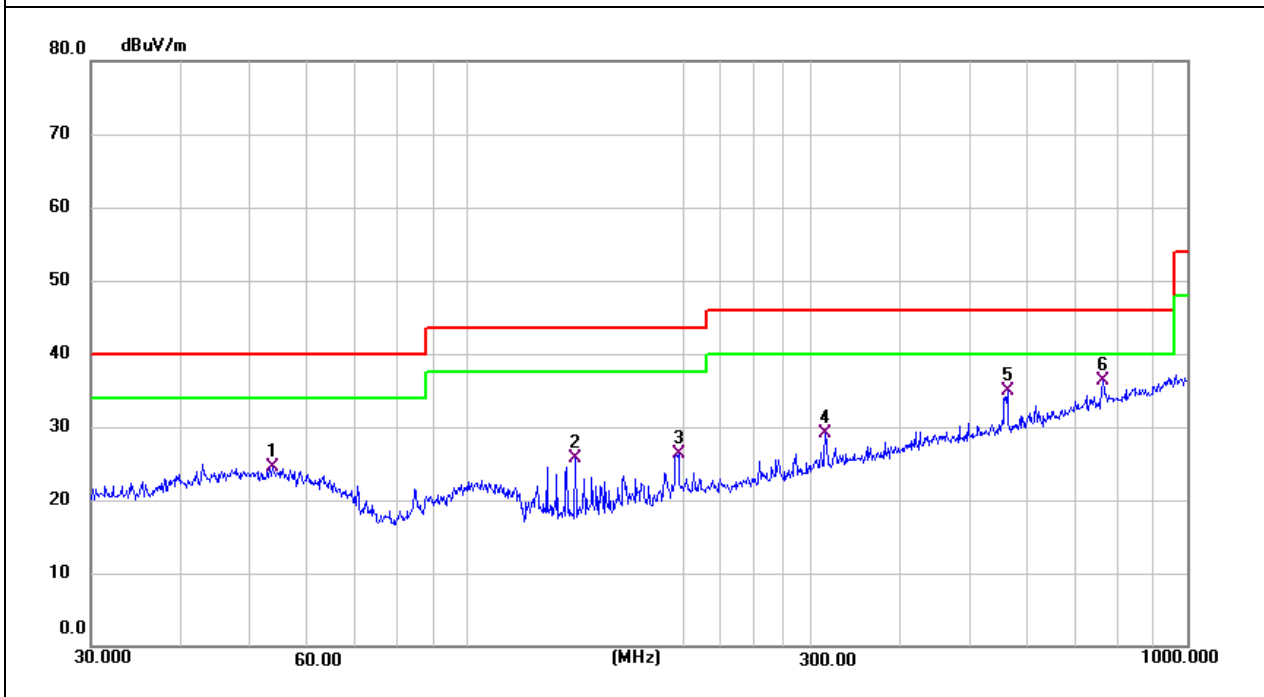

3.2.5 TEST RESULTS(1000~18000MHz)

EUT:	Mobile Phone	Model Name :	GQ5008TF
Temperature:	24.5 °C	Relative Humidity:	55%
Pressure:	1010 hPa	Test Date :	2024-08-14
Test Mode :	Mode 2		
Test Power :	DC 5V from PC AC 120V/60Hz		

All the modulation modes have been tested, and the worst result was report as below:

Polar (H/V)	Frequency	Reading	Correct	Result	Limit	Over Limit	Remark
	(MHz)	(dBuV/m)	dB/m	(dBuV/m)	(dBuV/m)	(dB)	
V	1527.000	47.07	-7.56	39.51	74.00	-34.49	peak
V	1527.000	35.76	-7.56	28.20	54.00	-25.80	AVG
V	3091.000	47.06	-2.63	44.43	74.00	-29.57	peak
V	3091.000	29.22	-2.63	26.59	54.00	-27.41	AVG
V	5862.000	44.19	3.47	47.66	74.00	-26.34	peak
V	5862.000	25.86	3.47	29.33	54.00	-24.67	AVG
V	8531.000	47.03	8.27	55.30	74.00	-18.70	peak
V	8531.650	31.98	8.28	40.26	54.00	-13.74	AVG
V	11761.000	46.36	11.37	57.73	74.00	-16.27	peak
V	11761.000	28.26	11.37	39.63	54.00	-14.37	AVG
V	15977.000	44.28	13.22	57.50	74.00	-16.50	peak
V	15977.000	28.93	13.22	42.15	54.00	-11.85	AVG
H	2326.000	47.79	-5.58	42.21	74.00	-31.79	peak
H	2326.000	33.60	-5.58	28.02	54.00	-25.98	AVG
H	3856.000	46.99	-1.09	45.90	74.00	-28.10	peak
H	3856.000	27.78	-1.09	26.69	54.00	-27.31	AVG
H	5879.000	46.34	3.51	49.85	74.00	-24.15	peak
H	5879.000	24.87	3.51	28.38	54.00	-25.62	AVG
H	8582.000	48.23	8.42	56.65	74.00	-17.35	peak
H	8582.000	32.84	8.42	41.26	54.00	-12.74	AVG
H	11421.000	48.01	11.90	59.91	74.00	-14.09	peak
H	11421.000	28.36	11.90	40.26	54.00	-13.74	AVG
H	15994.000	45.31	13.19	58.50	74.00	-15.50	peak
H	15994.000	29.07	13.19	42.26	54.00	-11.74	AVG

Remark:

Result = Reading + Correct, Over Limit= Result - Limit

Note: Only the worst results data points are reported in the report.

Other emissions are attenuated 20dB below the limit that does not recorded in the report.

END OF REPORT