

Project No.: TM-2308000131P  
Report No.: TMWK2308002725KR

FCC ID: 2AOUZ-23040401

Page 1 / 24  
Rev. 00

# FCC RADIO TEST REPORT

## FCC 47 CFR PART 15 SUBPART C

<b>Test Standard</b>	<b>FCC Part 15.209</b>
<b>Product name</b>	<b>VW instrument cluster</b>
<b>Model No.</b>	<b>23040401</b>
<b>Trade name</b>	<b>Continental</b>
<b>Operation Freq.</b>	<b>TX: 125 KHz</b>
<b>Test Result</b>	<b>Pass</b>
<b>Statements of Conformity</b>	<b>Determination of compliance is based on the results of the compliance measurement, not taking into account measurement instrumentation uncertainty.</b>

The test Result was tested by Compliance Certification Services Inc. The test data, data evaluation, test procedures, and equipment configurations shown in this report were given in ANSI C63.10: 2013 and compliance standards.

The test results of this report relate only to the tested sample (EUT) identified in this report.

The test Report of full or partial shall not copy. Without written approval of SGS Compliance Certification Services Inc. (Wugu Laboratory)

Approved by:



---

Shawn Wu  
Supervisor

Unless otherwise stated the results shown in this test report refer only to the sample(s) tested and such sample(s) are retained for 90 days only.  
除非另有說明，此報告結果僅對測試之樣品負責，同時此樣品僅保留90天。本報告未經本公司書面許可，不可部份複製。

This document is issued by the Company subject to its General Conditions of Service printed overleaf, available on request or accessible at <http://www.sgs.com.tw/Terms-and-Conditions> and, for electronic format documents, subject to Terms and Conditions for Electronic Documents at <http://www.sgs.com.tw/Terms-and-Conditions>. Attention is drawn to the limitation of liability, indemnification and jurisdiction issues defined therein. Any holder of this document is advised that information contained hereon reflects the Company's findings at the time of its intervention only and within the limits of client's instruction, if any. The Company's sole responsibility is to its Client and this document does not exonerate parties to a transaction from exercising all their rights and obligations under the transaction documents. This document cannot be reproduced, except in full, without prior written approval of the Company. Any unauthorized alteration, forgery or falsification of the content or appearance of this document is unlawful and offenders may be prosecuted to the fullest extent of the law.

### Revision History

Rev.	Issue Date	Revisions	Effect Page	Revised By
00	September 11, 2023	Initial Issue	ALL	Allison Chen

## Table of contents

1.	GENERAL INFORMATION .....	4
1.1	EUT INFORMATION .....	4
1.2	EUT CHANNEL INFORMATION .....	5
1.3	ANTENNA INFORMATION .....	5
1.4	MEASUREMENT UNCERTAINTY.....	6
1.5	FACILITIES AND TEST LOCATION .....	7
1.6	INSTRUMENT CALIBRATION.....	8
1.7	SUPPORT AND EUT ACCESSORIES EQUIPMENT .....	9
1.8	TEST METHODOLOGY AND APPLIED STANDARDS .....	9
2.	TEST SUMMARY .....	10
3.	DESCRIPTION OF TEST MODES.....	11
3.1	THE WORST MODE OF OPERATING CONDITION .....	11
3.2	THE WORST MODE OF MEASUREMENT .....	11
3.3	FCC PART 15.205 RESTRICTED BANDS OF OPERATIONS.....	12
4.	TEST RESULT .....	13
4.1	20DB BANDWIDTH.....	13
4.2	TRANSMITTER RADIATED EMISSION.....	15
4.3	AC POWER LINE CONDUCTED EMISSION .....	23
4.4	ANTENNA REQUIREMENT .....	24
<b>APPENDIX 1 – PHOTOGRAPHS OF EUT</b>		

Report No.: TMWK2308002725KR

## 1. GENERAL INFORMATION

### 1.1 EUT INFORMATION

Applicant	Continental Automotive Technologies GmbH VDO-Strasse 1 64832 Babenhausen Germany
Manufacturer	Continental Automotive Technologies GmbH VDO-Strasse 1 64832 Babenhausen Germany
Factory	Continental Brasil Indústria Automotiva Ltda Av. Senador Adolf Schindling 131 Guarulhos - SP 07042-020 Brazil
Equipment	VW instrument cluster
Model Name	23040401
Model Discrepancy	N/A
Received Date	August 10, 2023
Date of Test	August 14~15, 2023
Power Operation	Power from power supply. (DC 12V)
Operation Frequency	TX: 125 KHz
H/W Version	HH10
S/W Version	S0011

**Remark:**

1. For more details, please refer to the User's manual of the EUT.
2. Disclaimer: Antenna information is provided by the applicant, test results of this report are applicable to the sample EUT received.

Report No.: TMWK2308002725KR

## 1.2 EUT CHANNEL INFORMATION

Frequency Range	TX: 125 KHz
Modulation Type	ASK

**Remark:**

Refer as ANSI 63.10:2013 clause 5.6.1 Table 4 for test channels

Number of frequencies to be tested		
Frequency range in which device operates	Number of frequencies	Location in frequency range of operation
<input checked="" type="checkbox"/> 1 MHz or less	1	Middle
<input type="checkbox"/> 1 MHz to 10 MHz	2	1 near top and 1 near bottom
<input type="checkbox"/> More than 10 MHz	3	1 near top, 1 near middle, and 1 near bottom

## 1.3 ANTENNA INFORMATION

Antenna Type	Air coil antenna
Brand / Model	1. VW / 8E0.905.855.D 2. Huf / 36295101

**Remark:**

1. Disclaimer: Antenna information is provided by the applicant, test results of this report are applicable to the sample EUT received.

## 1.4 MEASUREMENT UNCERTAINTY

PARAMETER	UNCERTAINTY
AC Powerline Conducted Emission	$\pm 2.213$ dB
Channel Bandwidth	$\pm 2.7$ %
Radiated Emission_9kHz-30MHz	$\pm 3.761$ dB
Radiated Emission_30MHz-200MHz	$\pm 3.473$ dB
Radiated Emission_200MHz-1GHz	$\pm 3.946$ dB

**Remark:**

- 1.This uncertainty represents an expanded uncertainty expressed at approximately the 95% confidence level using a coverage factor of  $k=2$
2. ISO/IEC 17025 requires that an estimate of the measurement uncertainties associated with the emissions test results be included in the report.

Report No.: TMWK2308002725KR

## 1.5 FACILITIES AND TEST LOCATION

All measurement facilities used to collect the measurement data are located at

No.11, Wugong 6th Rd., Wugu Dist., New Taipei City, Taiwan

No. 12, Ln. 116, Wugong 3rd Rd., Wugu Dist., New Taipei City, Taiwan

CAB identifier: TW1309

Test site	Test Engineer	Remark
AC Conduction Room	-	Not applicable, because EUT doesn't connect to AC Main Source direct.
Radiation	Ray Li	-
Conducted	David Li	-

**Remark:** The sites are constructed in conformance with the requirements of ANSI C63.7, ANSI C63.4 and CISPR Publication 22.

Report No.: TMWK2308002725KR

## 1.6 INSTRUMENT CALIBRATION

3M 966A Chamber Test Site_125K					
Equipment	Manufacturer	Model	S/N	Cal Date	Cal Due
PXA Signal Analyzer	Keysight Technologies	N9030B	MY62291089	2022-10-14	2023-10-13
Loop Antenna	COM-POWER	AL-130	121051	2023-05-23	2024-05-22
Preamplifier	EMEC	EM330	060609	2023-02-22	2024-02-21
Thermo-Hygro Meter	WISEWIND	1206	D07	2022-12-19	2023-12-18
Bi-Log Antenna	Sunol Sciences	JB3	A030105	2023-08-08	2024-08-07
Cable	Huber+Suhner	104PEA	20995+21000+18 2330	2023-02-22	2024-02-21
Turn Table	CCS	CC-T-1F	N/A	N.C.R	N.C.R
Controller	CCS	CC-C-1F	N/A	N.C.R	N.C.R
Antenna Tower	CCS	CC-A-1F	N/A	N.C.R	N.C.R
<b>Software</b>	e3 V9-210616c				

Conducted					
Equipment	Manufacturer	Model	S/N	Cal Date	Cal Due
Loop Probe	LANGER EMV-TECHNIK	RF-R 50-1	02-2644	2023-01-13	2024-01-12
DC Power Supply	GWINSTEK	SPS-3610	GPE880163	2022-12-02	2023-12-01
EXA Signal Analyzer	Keysight	N9010B	MY55460167	2022-09-07	2023-09-06
<b>Software</b>	N/A				

**Remark:**

1. Each piece of equipment is scheduled for calibration once a year.
2. N.C.R. = No Calibration Required.



## 1.7 SUPPORT AND EUT ACCESSORIES EQUIPMENT

There are no accessories and support equipment be used during the test.

EUT Accessories Equipment					
No.	Equipment	Brand	Model	Series No.	FCC ID
	N/A				

Support Equipment					
No.	Equipment	Brand	Model	Series No.	FCC ID
1	Power Supply	ABM	9603D-D011314	N/A	N/A

## 1.8 TEST METHODOLOGY AND APPLIED STANDARDS

The test methodology, setups and results comply with all requirements in accordance with ANSI C63.10:2013, FCC 15.209.

## 2. TEST SUMMARY

<b>FCC Standard Sec.</b>	<b>Chapter</b>	<b>Test Item</b>	<b>Result</b>
15.215	4.1	20dB Bandwidth & 99% OBW	Pass
15.209	4.2	Transmitter Radiated Emission	Pass
15.207	4.3	AC Power-line Conducted Emission	Not applicable
15.203	4.4	Antenna Requirement	Pass

Report No.: TMWK2308002725KR

### 3. DESCRIPTION OF TEST MODES

#### 3.1 THE WORST MODE OF OPERATING CONDITION

Operation mode	TX: 125KHz
RF Field strength	<u>Peak: -6.03 dBuV/m @300m</u>

#### 3.2 THE WORST MODE OF MEASUREMENT

Radiated Emission Measurement Above 1G	
<b>Test Condition</b>	<b>Radiated Emission Above 1G</b>
<b>Power supply Mode</b>	<b>Mode 1: EUT power by Power supply</b>
<b>Worst Mode</b>	<input checked="" type="checkbox"/> Mode 1 <input type="checkbox"/> Mode 2 <input type="checkbox"/> Mode 3 <input type="checkbox"/> Mode 4
<b>Worst Position</b>	<input type="checkbox"/> Placed in fixed position. <input checked="" type="checkbox"/> Placed in fixed position at X-Plane (E2-Plane) <input type="checkbox"/> Placed in fixed position at Y-Plane (E1-Plane) <input type="checkbox"/> Placed in fixed position at Z-Plane (H-Plane)

Radiated Emission Measurement Below 1G	
<b>Test Condition</b>	<b>Radiated Emission Below 1G</b>
<b>Power supply Mode</b>	<b>Mode 1: EUT power by Power supply</b>
<b>Worst Mode</b>	<input checked="" type="checkbox"/> Mode 1 <input type="checkbox"/> Mode 2 <input type="checkbox"/> Mode 3 <input type="checkbox"/> Mode 4

Remark:

1. The worst mode was record in this test report.
2. EUT pre-scanned in three axis ,X,Y, Z and two polarity, for radiated measurement. The worst case(X-Plane) were recorded in this report

Report No.: TMWK2308002725KR

### 3.3 FCC PART 15.205 RESTRICTED BANDS OF OPERATIONS

According to FCC 15.205,

(a) Except as shown in other rules, only spurious emissions are permitted in any of the frequency bands listed below:

MHz	MHz	MHz	GHz
0.090 - 0.110	16.42 - 16.423	399.9 - 410	4.5 - 5.15
<sup>1</sup> 0.495 - 0.505	16.69475 - 16.69525	608 - 614	5.35 - 5.46
2.1735 - 2.1905	16.80425 - 16.80475	960 - 1240	7.25 - 7.75
4.125 - 4.128	25.5 - 25.67	1300 - 1427	8.025 - 8.5
4.17725 - 4.17775	37.5 - 38.25	1435 - 1626.5	9.0 - 9.2
4.20725 - 4.20775	73 - 74.6	1645.5 - 1646.5	9.3 - 9.5
6.215 - 6.218	74.8 - 75.2	1660 - 1710	10.6 - 12.7
6.26775 - 6.26825	108 - 121.94	1718.8 - 1722.2	13.25 - 13.4
6.31175 - 6.31225	123 - 138	2200 - 2300	14.47 - 14.5
8.291 - 8.294	149.9 - 150.05	2310 - 2390	15.35 - 16.2
8.362 - 8.366	156.52475 -	2483.5 - 2500	17.7 - 21.4
8.37625 - 8.38675	156.52525	2655 - 2900	22.01 - 23.12
8.41425 - 8.41475	156.7 - 156.9	3260 - 3267	23.6 - 24.0
12.29 - 12.293	162.0125 - 167.17	3332 - 3339	31.2 - 31.8
12.51975 - 12.52025	167.72 - 173.2	3345.8 - 3358	36.43 - 36.5
12.57675 - 12.57725	240 - 285	3600 - 4400	( <sup>2</sup> )
13.36 - 13.41	322 - 335.4		

<sup>1</sup> Until February 1, 1999, this restricted band shall be 0.490-0.510 MHz.

<sup>2</sup> Above 38.6

(b) Except as provided by other rules, the field strength of emissions appearing within these frequency bands shall not exceed the limits shown in Section 15.209. At frequencies equal to or less than 1000 MHz, compliance with the limits in Section 15.209 shall be demonstrated using measurement instrumentation employing a CISPR quasi-peak detector. Above 1000 MHz, compliance with the emission limits in Section 15.209 shall be demonstrated based on the average value of the measured emissions. The provisions in Section 15.35 apply to these measurements.

Report No.: TMWK2308002725KR

## 4. TEST RESULT

### 4.1 20DB BANDWIDTH

#### DEFINITION

According to FCC Part 15.215 (c) ,Intentional radiators operating under the alternative provisions to the general emission limits, as contained in §§15.217 through 15.257 and in subpart E of this part, must be designed to ensure that the 20 dB bandwidth of the emission, or whatever bandwidth may otherwise be specified in the specific rule section under which the equipment operates, is contained within the frequency band designated in the rule section under which the equipment is operated.

#### TEST CONFIGURATION

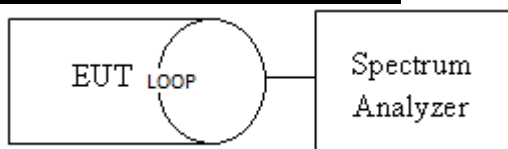

#### TEST PROCEDURE

The Loop antenna connected to the spectrum analyzer, was touching to the transmitter antenna. Set the RBW=1KHz, VBW  $\geq 3 \times$  RBW, Detector = Peak, Trace mode = Max hold, Sweep = 500ms.Measure the maximum width of the emission that is constrained by the frequencies associated with the Occupied Bandwidth.

#### TEST RESULTS

Compliance

Report No.: TMWK2308002725KR

## Test Data

Temperature: 25.6°C      Test Date: August 14, 2023  
Humidity: 54% RH      Tested By: David Li

20 dB Bandwidth (kHz)			99% Bandwidth (kHz)
FL	FH	Bandwidth	
120.413	130.164	9.751	9.75

## Test Plots

### 20dB & 99%OBW



Report No.: TMWK2308002725KR

## 4.2 TRANSMITTER RADIATED EMISSION

### LIMIT

1. According to FCC PART 15.209(a), except as provided elsewhere in this Subpart, the emissions from an intentional radiator shall not exceed the field strength levels specified in the following table:

Frequency (MHz)	Field Strength ( $\mu\text{V/m}$ )	Measurement Distance (m)
0.009 - 0.490	2400/F(kHz)	300
0.490 - 1.705	24000/F(kHz)	30
1.705 – 30.0	30	30
30-88	100	3
88-216	150	3
216-960	200	3
Above 960	500	3

**Remark:** Except as provided in other rules, fundamental emissions from intentional radiators operating under this Section shall not be located in the frequency bands 54-72 MHz, 76-88 MHz, 174-216 MHz or 470-806 MHz. However, operation within these frequency bands is permitted under other sections of this Part, e.g., Sections 15.231 and 15.241.

2. In the above emission table, the tighter limit applies at the band edges.

### Above 30MHz

Frequency (MHz)	Field Strength		Measurement Distance (meter)
	( $\mu\text{V/m}$ )	(dB $\mu\text{V/m}$ )	
30-88	100	40.0	3
88-216	150	43.5	3
216-960	200	46.0	3
Above 960	500	54.0	3

## Test Configuration

### 9kHz ~ 30MHz

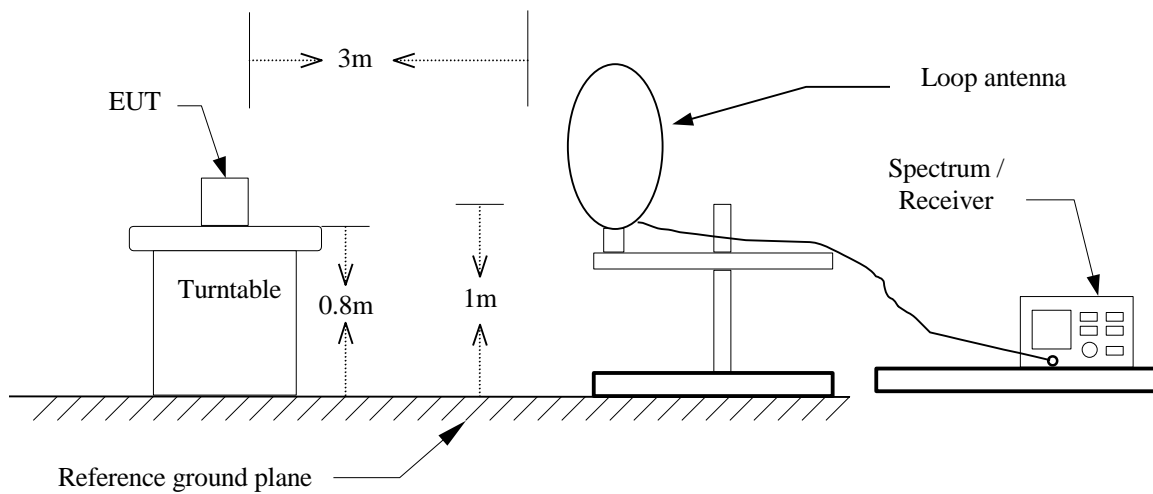

### 30MHz ~ 1GHz

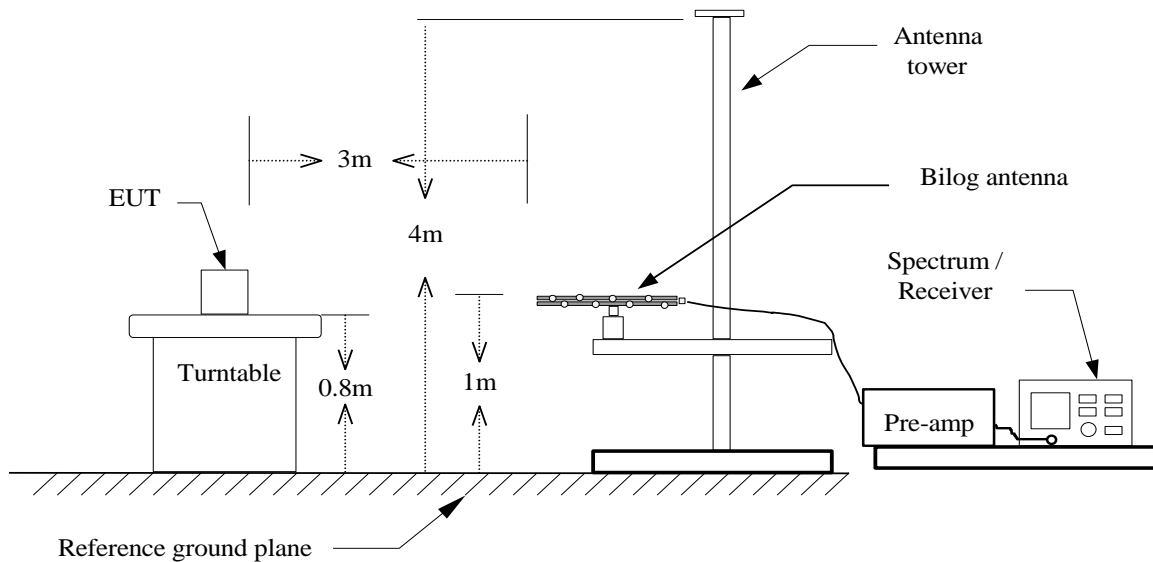



Report No.: TMWK2308002725KR

## **TEST PROCEDURE**

### **For 9KHz ~ 30MHz**

1. The EUT is placed on a turntable, which is 0.8m above ground plane.
2. The turntable shall be rotated for 360 degrees to determine the position of maximum emission level.
3. EUT is set 3m away from the receiving antenna, which is varied from 1m to find out the highest emissions.
4. Maximum procedure was performed on the six highest emissions to ensure EUT compliance.
5. And also, each emission was to be maximized by changing the polarization of receiving antenna both horizontal and vertical.
6. Set the spectrum analyzer in the following setting as:  
Below 1GHz:  
RBW=200kHz / VBW=600kHz / Sweep=AUTO
7. Repeat above procedures until the measurements for all frequencies are complete.
8. Test distance for frequencies at below 30 MHz, measurements may be performed at a distance closer than the EUT limit distance; however, an attempt should be made to avoid making measurements in the near field. When performing measurements below 30 MHz at a closer distance than the limit distance, the results shall be extrapolated to the specified distance by either making measurements at a minimum of two or more distances on at least one radial to determine the proper extrapolation factor or by using the square of an inverse linear distance extrapolation factor (40 dB/decade). The test report shall specify the extrapolation method used to determine compliance of the EUT.

### **For 30MHz ~ 1GHz**

1. The EUT is placed on a turntable, which is 0.8m above ground plane.
2. The turntable shall be rotated for 360 degrees to determine the position of maximum emission level.
3. EUT is set 3m away from the receiving antenna, which is varied from 1m to 4m to find out the highest emissions.
4. Maximum procedure was performed on the six highest emissions to ensure EUT compliance.
5. And also, each emission was to be maximized by changing the polarization of receiving antenna both horizontal and vertical.
6. Set the spectrum analyzer in the following setting as:  
RBW=100kHz / VBW=300kHz / Sweep=AUTO
7. Repeat above procedures until the measurements for all frequencies are complete.

Report No.: TMWK2308002725KR

### Fundamental Strength

**Operation Mode:** Main

**Temperature:** 24.5°C

**Test Date:** August 15, 2023

**Humidity:** 57% RH

**Tested by:** Ray Li

#### **Antenna Pol.: Vertical**

Freq.	Detector Mode	Spectrum Read Level @3m	Factor @3m	Actual FS @3m	Factor @30m&300m	Actual FS @30m&300m	Limit	Margin
MHz	PK/QP/AV	dB $\mu$ V	dB	dB $\mu$ V/m	dB	dB $\mu$ V/m	dB $\mu$ V/m	dB
0.125	Peak	60.20	13.77	73.97	-80.00	-6.03	25.67	-31.69

#### **Antenna Pol.: Horizontal**

Freq.	Detector Mode	Spectrum Read Level @3m	Factor @3m	Actual FS @3m	Factor @30m&300m	Actual FS @30m&300m	Limit	Margin
MHz	PK/QP/AV	dB $\mu$ V	dB	dB $\mu$ V/m	dB	dB $\mu$ V/m	dB $\mu$ V/m	dB
0.125	Peak	58.71	13.77	72.49	-80.00	-7.51	25.67	-33.18

#### **Antenna Pol.: Ground**

Freq.	Detector Mode	Spectrum Read Level @3m	Factor @3m	Actual FS @3m	Factor @30m&300m	Actual FS @30m&300m	Limit	Margin
MHz	PK/QP/AV	dB $\mu$ V	dB	dB $\mu$ V/m	dB	dB $\mu$ V/m	dB $\mu$ V/m	dB
0.125	Peak	60.20	13.77	73.97	-80.00	-6.03	25.67	-31.69

**Remark:**

1. Since the Factor included the distance conversion factor, the distance of Actual FS is 300m or 30m. (9kHz~490kHz is 300m, 490kHz~30MHz is 30m)

### Antenna Pol.: Vertical

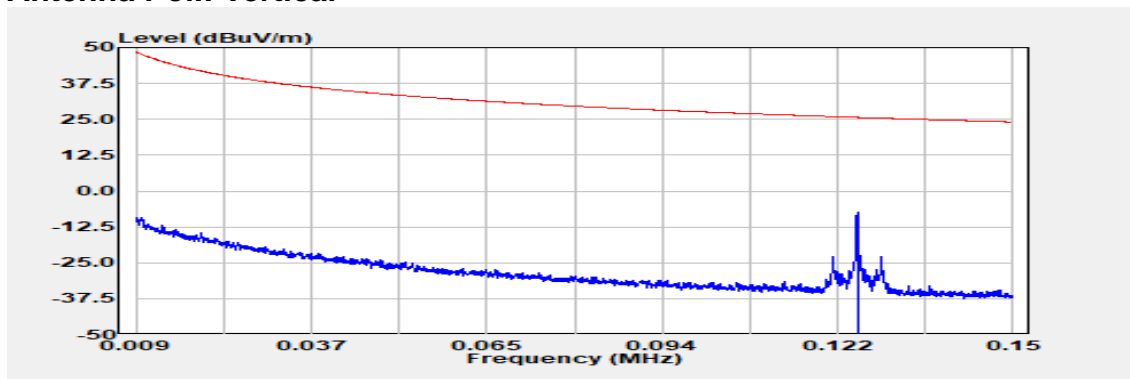

### Antenna Pol.: Horizontal

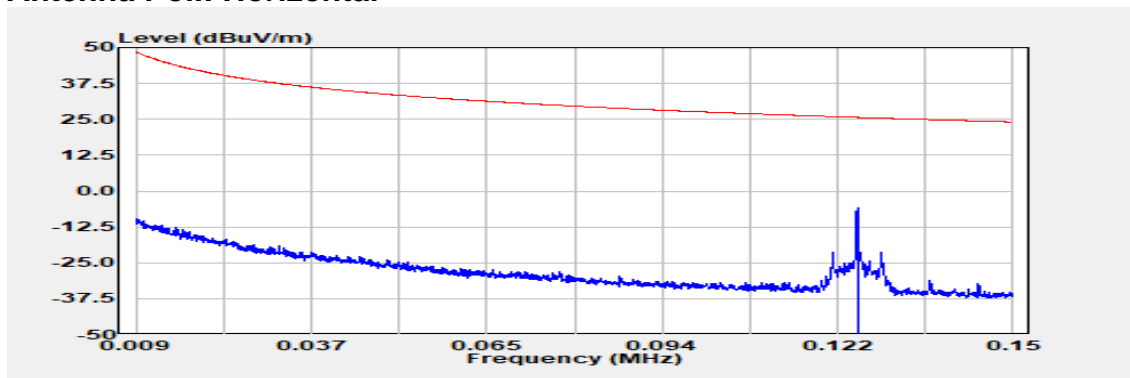

### Antenna Pol.: Ground

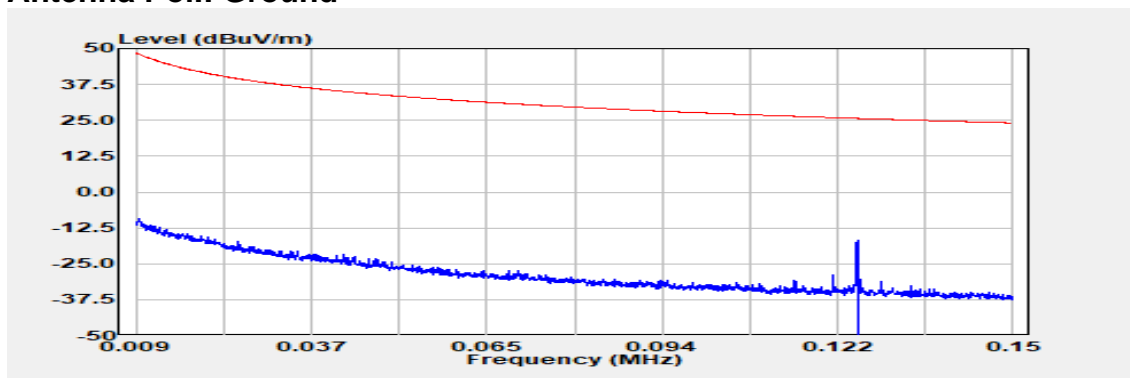

Report No.: TMWK2308002725KR

## 9 kHz – 30MHz

Operation Mode: TX 125KHz

Antenna Pol.: Horizontal

Temperature: 24.5°C

Test Date: August 15, 2023

Humidity: 57% RH

Tested by: Ray Li

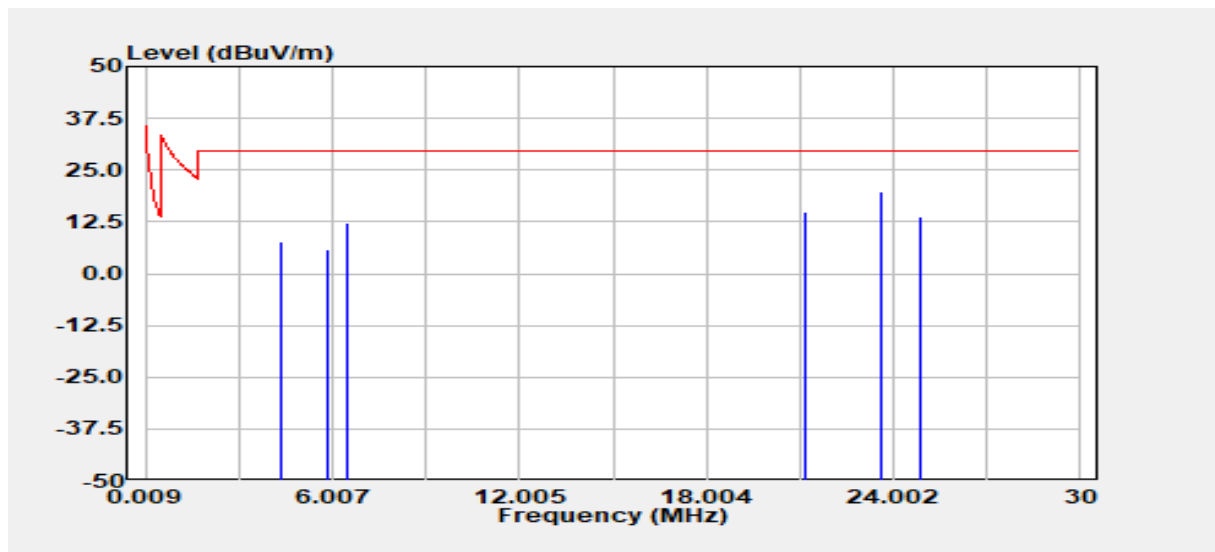

Freq. MHz	Detector Mode PK/QP/AV	Spectrum Read Level @3m dBμV	Factor @3m dB	Actual FS @3m dBμV/m	Factor @30m&300m dB	Actual FS @30m&300m dBμV/m	Limit dBμV/m	Margin dB
4.377	Peak	31.99	15.68	47.67	-40.00	7.67	29.54	-21.87
5.863	Peak	29.38	16.57	45.95	-40.00	5.95	29.54	-23.59
6.496	Peak	35.93	16.52	52.45	-40.00	12.45	29.54	-17.09
21.206	Peak	37.88	16.97	54.85	-40.00	14.85	29.54	-14.69
23.594	Peak	43.42	16.30	59.72	-40.00	19.72	29.54	-9.82
24.836	Peak	36.39	17.23	53.63	-40.00	13.63	29.54	-15.91

**Remark:**

1. the frequency bands 9-90 kHz, 110-490 kHz measurements employing an average detector and other below 1GHz measurements employing a CISPR quasi-peak detector.
2. Since the Factor included the distance conversion factor, the distance of Actual FS is 300m or 30m. (9kHz~490kHz is 300m, 490kHz~30MHz is 30m)

Report No.: TMWK2308002725KR

## Below 1 GHz

**Operation Mode:** TX 125KHz

**Antenna Pol.:** Vertical

**Temperature:** 24.5°C

**Test Date:** August 15, 2023

**Humidity:** 57% RH

**Tested by:** Ray Li

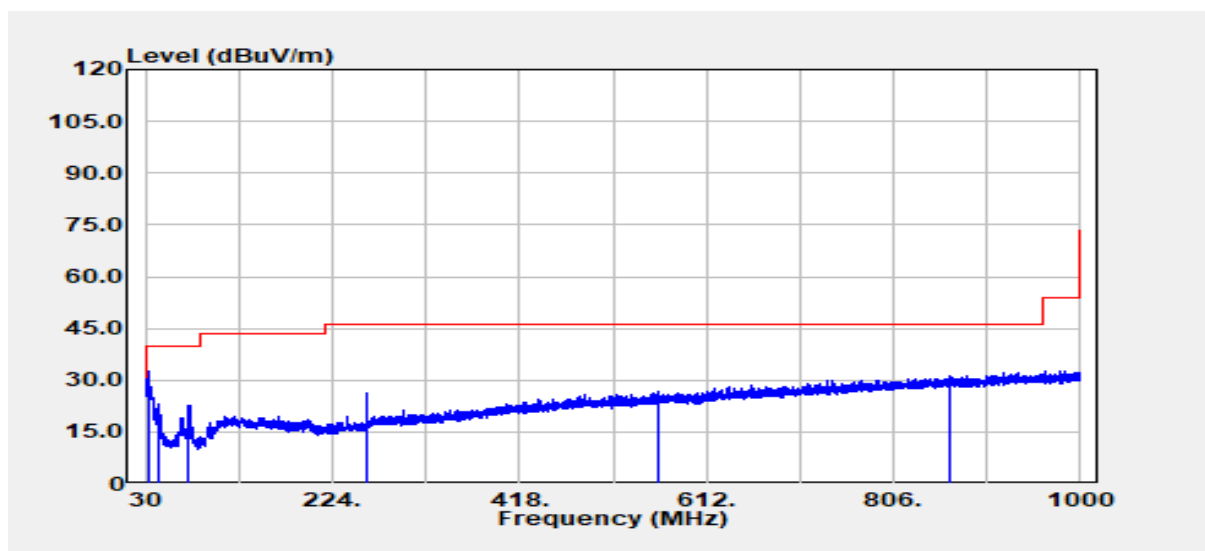

Freq. (MHz)	Detector Mode (PK/QP/AV)	Spectrum Reading Level (dB $\mu$ V)	Factor (dB)	Actual FS (dB $\mu$ V/m)	Limit @3m (dB $\mu$ V/m)	Margin (dB)
33.52	Peak	37.47	-4.93	32.54	40.00	-7.46
43.58	Peak	35.39	-12.40	22.99	40.00	-17.01
74.98	Peak	38.07	-15.50	22.57	40.00	-17.43
259.41	Peak	36.56	-10.09	26.47	46.00	-19.53
563.14	Peak	29.30	-2.42	26.88	46.00	-19.12
864.08	Peak	28.71	2.57	31.28	46.00	-14.72

**Operation Mode:** TX 125KHz

**Antenna Pol.:** Horizontal

**Temperature:** 24.5°C

**Test Date:** August 15, 2023

**Humidity:** 57% RH

**Tested by:** Ray Li

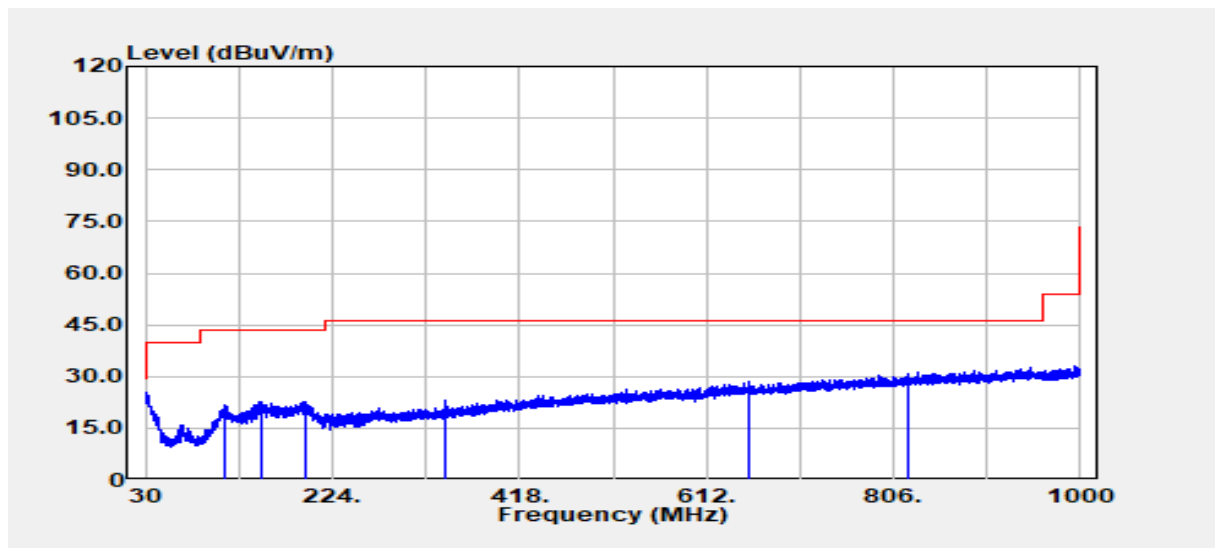

Freq. (MHz)	Detector Mode (PK/QP/AV)	Spectrum Reading Level (dBμV)	Factor (dB)	Actual FS (dBμV/m)	Limit @3m (dBμV/m)	Margin (dB)
112.94	Peak	31.96	-10.02	21.94	43.50	-21.56
151.25	Peak	33.26	-10.48	22.78	43.50	-20.72
194.90	Peak	32.99	-10.52	22.47	43.50	-21.03
341.61	Peak	30.68	-7.76	22.92	46.00	-23.08
656.50	Peak	29.13	-0.70	28.42	46.00	-17.58
819.94	Peak	29.00	1.87	30.87	46.00	-15.13

## 4.3 AC POWER LINE CONDUCTED EMISSION

### 4.3.1 Test Limit

According to §15.207(a),

Frequency Range (MHz)	Limits(dB $\mu$ V)	
	Quasi-peak	Average
0.15 to 0.50	66 to 56*	56 to 46*
0.50 to 5	56	46
5 to 30	60	50

\* Decreases with the logarithm of the frequency.

### 4.3.2 Test Procedure

Test method Refer as ANSI 63.10:2013 clause 6.2,

1. The EUT was placed on a table, which is 0.8m above ground plane.
2. Maximum procedure was performed on the six highest emissions to ensure EUT compliance.
3. Repeat above procedures until all frequency measured were complete

### 4.3.3 Test Setup

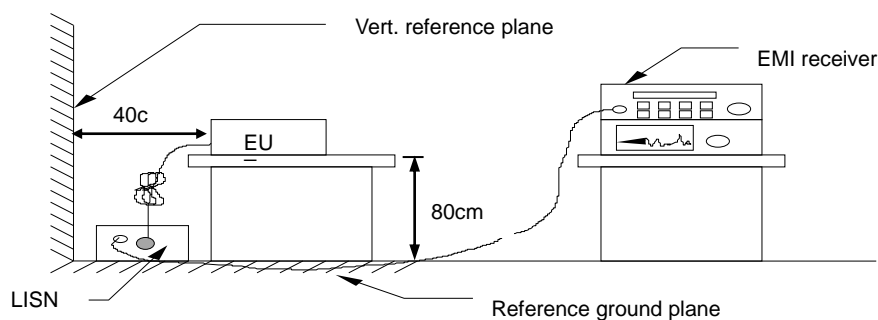

### 4.3.4 Test Result

Not applicable, because EUT doesn't connect to AC Main Source direct.

Report No.: TMWK2308002725KR

## 4.4 ANTENNA REQUIREMENT

### § 15.203 Antenna requirement.

An intentional radiator shall be designed to ensure that no antenna other than that furnished by the responsible party shall be used with the device. The use of a permanently attached antenna or of an antenna that uses a unique coupling to the intentional radiator shall be considered sufficient to comply with the provisions of this section. The manufacturer may design the unit so that a broken antenna can be replaced by the user, but the use of a standard antenna jack or electrical connector is prohibited. This requirement does not apply to carrier current devices or to devices operated under the provisions of §15.211, §15.213, §15.217, §15.219, or §15.221. Further, this requirement does not apply to intentional radiators that must be professionally installed, such as perimeter protection systems and some field disturbance sensors, or to other intentional radiators which, in accordance with §15.31(d), must be measured at the installation site. However, the installer shall be responsible for ensuring that the proper antenna is employed so that the limits in this part are not exceeded.

<b>Antenna Type</b>	Air coil antenna
<b>Brand / Model</b>	VW / 8E0.905.855.D

**Remark:**

1.The antenna(s) of the EUT are permanently attached and there are no provisions for connection to an external antenna. So the EUT complies with the requirements of §15.203.

**- End of Test Report -**