

**Annex Products (Quad Lock)**  
 Como Centre, Level 3, Suite 6A,  
 299 Toorak Rd, South Yarra  
 VIC 3141, Australia  
 Phone: +61 3 9069 9698  
 info@quadlock.com.au

### LABEL LOCATION EXHIBIT

Due to the size, appearance, shape and shell material of the product, the warning words related to the requirements of FCC PART 15.19 cannot be placed on the product mainbody, thus the content of the warning words will be described in the instruction manual.

The warning words of FCC PART 15.19:

This device complies with part 15 of the FCC Rules. Operation is subject to the following two conditions:  
 (1) This device may not cause harmful interference, and (2) this device must accept any interference received, including interference that may cause undesired operation.

SIZE: 50mm x 50mm

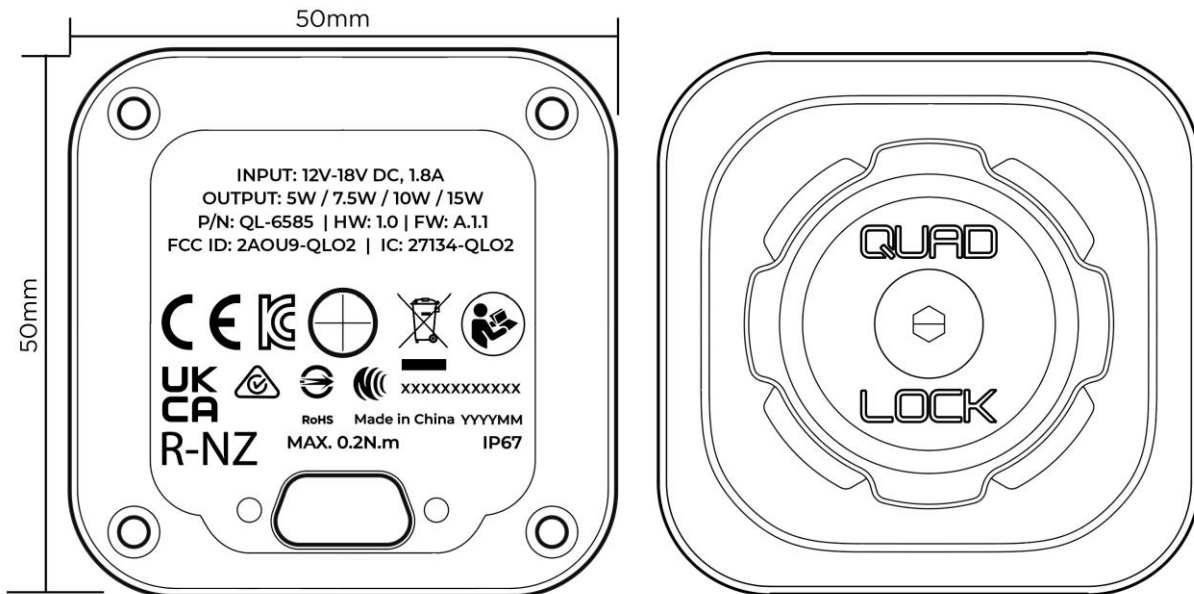

*By signing this document, I acknowledge I have read and understand the above information*

Print Name:	Chris Peters	Date:	20th Dec, 2023
Signature:	