

东莞市金赞智能科技有限公司

DONGGUAN KIMCHEN INDUSTRY INTL LIMITED



DONGGUAN KIMCHEN INDUSTRY INTL LIMITED

SPECIFICATION FOR APPROVAL

Shenzhen Huagon Technology Co., LTD

CUSTOMER: \_\_\_\_\_

DXQ022.0074

CUST P/N: \_\_\_\_\_

DXQ022.0074

K C P/N: \_\_\_\_\_

20.5\*40\*0.08\*80P\*10TS\*10MM

D E S E : \_\_\_\_\_

2023.2.20

D A T E : \_\_\_\_\_

A.0

VERSION : \_\_\_\_\_

ACCEPTANCE STAMP

PREPARED BY	MERCHANDISER	ENGINEER CHECKED BY	PRODUCTION CHECKDED BY	APPROVED BY
Yunfan Wang				

Address: No2 Xisha Road Shijie Guangdong 523290 Guangdong China

FiNo: KC-JZ-09-008



东莞市金赞智能科技有限公司

DONGGUAN KIMCHEN INDUSTRY INTL LIMITED

<b>Specification</b>	CUST P/N	DXQ022.0074
	Des. ,	20.5*40*0.08*80P*10TS*10MM

1. OVERALL DIMENSIONS OF PRODUCTS):

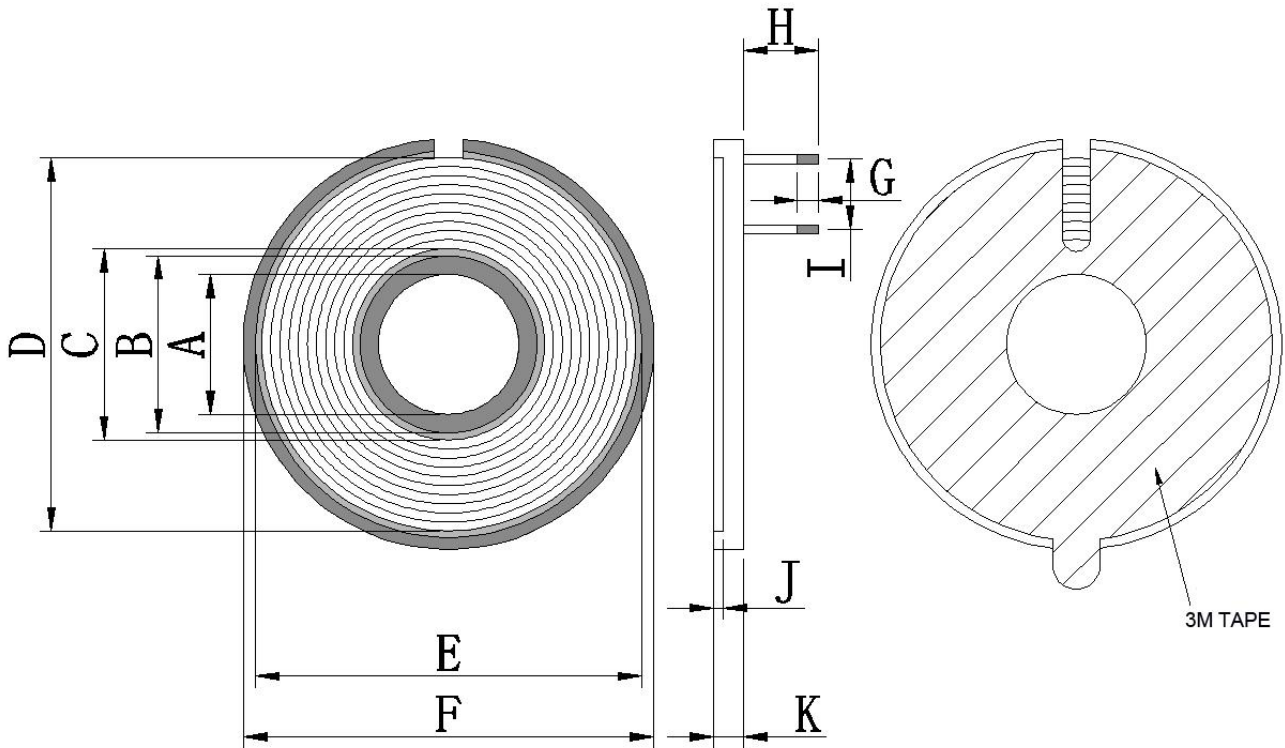

A	B	C	D	E	F	G	H	I	J	K
15MIN	19±0.3	20.5±0.3	40±1	41.4MIN	43-44MAX	3±1.5	10±1	10 REF	0.85±0.1	3.2MAX

Turns	Wire Diameter	Winding Direction	Lead wire Intersect Yes/Not	Coil front/reverse Paste
10	0.08*80P Litz wire	CCW	Not	reverse Paste

PREPARED BY	ENGINEER CHECKED BY	PRODUCTION CHECKED BY
Yunfan Wang	胡志军	王海波

Address: No2 Xisha Road Shijie Guangdong 523290 Guangdong China

FileNo: KC-JZ-09-008

东莞市金赞智能科技有限公司

DONGGUAN KIMCHEN INDUSTRY INTL LIMITED

<b>Specification</b>	CUST P/N	DXQ022.0074
	Des. ,	20.5*40*0.08*80P*10TS*10MM

## 2. ELECTRICAL CHARACTERISTICS :

TEMPERATURE: 25 ± 10°C, RELATIVE HUMIDITY: 65 ± 10%

NO.	ITEM	TERMINAL	VALUE	TEST FREQUENCY	TEST EQUIPMENTS
1	IND	S-F	Coil 3.6uH ± 10%	100kHz/V	LCZ METER 1062
2	IND	S-F	Coil+ferrite 6.7 uH ± 10%	100kHz/V	LCZ METER 1062
3	DCR	S-F	55m Ω MAX	1kHz/V	LCZ METER 1062

## 3. BILL OF MATERIAIS :

NO.	Material name	Description	Material Code	Vendor code
1	Wire	0.08*80P Litz Wire	JX-2U-F-0025	ZY
2	Ferrite Core	44*15*2.8H(with hole and Groove)	GCP-00142	KL
2	Double side tape (3M 9448A)	42*Hole 15.5*Groove dia 3mm, Groove Lenght 12mm	SMJ-3M-00081	WY
3	Epoxy Glue	JS-E7202	E7202W	HZY
4	Tin rod	Lead-free tin	Lead-free tin	XC

PREPARED BY	ENGINEER CHECKED BY	PRODUCTION CHECKED BY
Yunfan Wang	胡志军	王海波

Address: No2 Xisha Road Shijie Guangdong 523290 Guangdong China

FileNo: KC-JZ-09-008