

TURNING OFF INDICATOR LEDS

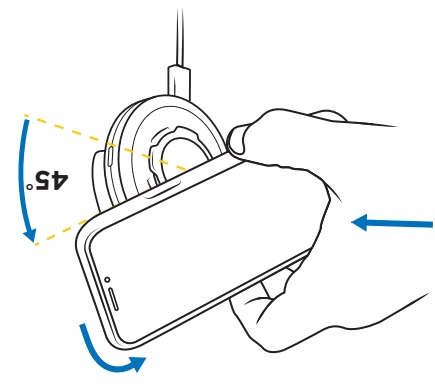

ATTACHING YOUR QUAD LOCK CASE

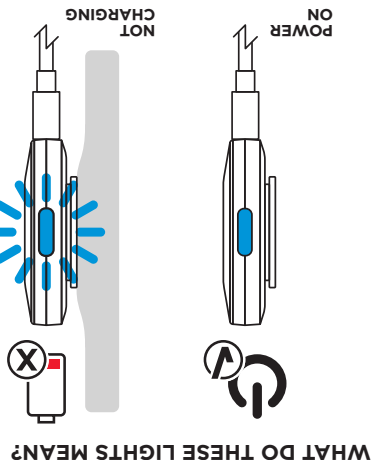
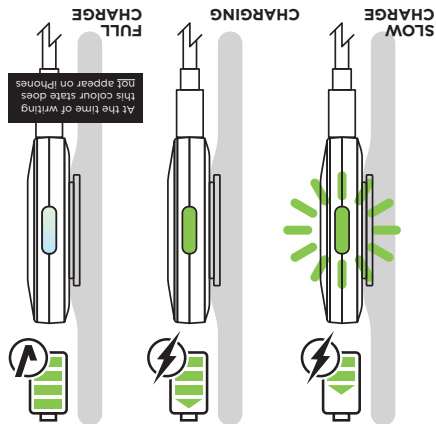
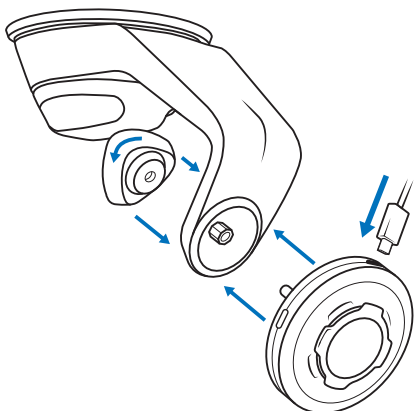

ATTACHING WIRELESS CHARGING HEAD

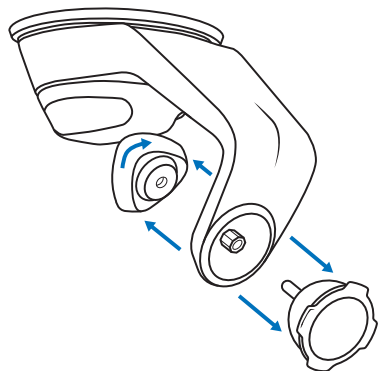

REMOVING CAR MOUNT HEAD

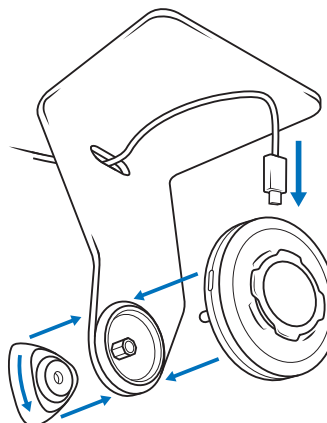

ATTACHING WIRELESS CHARGING HEAD

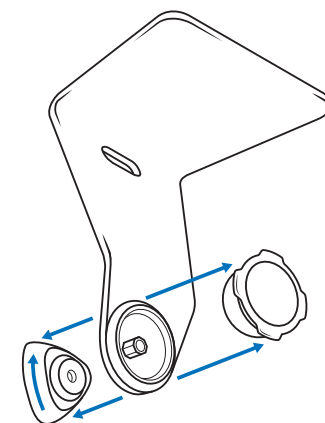

REMOVING DESK MOUNT HEAD

FC STATEMENT OF COMPLIANCE

This device complies with part 15 of the FCC Rules and RSS-Gen of IC Rules. Operation is subject to the following two conditions: (1) This device may not cause harmful interference, and (2) this device must accept any interference received, including interference that may cause undesired operation.

NOTE: This equipment has been tested and found to comply with the limits for a Class B digital device, pursuant to part 15 of the FCC Rules. These limits are designed to provide reasonable protection against harmful interference in a residential installation. This equipment generates, uses, and can radiate radio frequency energy and, if not installed and used in accordance with the instructions, may cause harmful interference to radio communications. However, there is no guarantee that interference will not occur in a particular installation. If this equipment does cause harmful interference to radio or television reception, which can be determined by turning the equipment off and on, the user is encouraged to try to correct the interference by one or more of the following measures:

- Reorient or relocate the receiving antenna.
- Increase the separation between the equipment and receiver.
- Connect the equipment into an outlet on a circuit different from that to which the receiver is connected.
- Consult the dealer or an experienced technician for help.

CAUTION: To comply with the limits of the Class B digital device, pursuant to Part 15 of the FCC Rules, this device must be used with certified peripherals and shielded cables. All peripherals must be shielded and grounded. Operation with non-certified peripherals or non-shielded cables may result in interference to radio or reception.

To comply with RF exposure compliance requirements, the wireless charging base must be used with a separation distance of at least 10cm from all persons. For 10W Fast Charge Mode, a Quick Charge 3.0 adapter must be used for the power input in conjunction with a 3A USB cable.

FC LOCATION OF TRANSMITTER IN VEHICLE

Immobilizer system only
The transmitter should be installed a safe distance (minimum 10 cm) away from the immobilizer system (i.e., steering lock or key fob docking station).

Passive start systems
The transmitter should be installed a safe distance (minimum 10 cm) away from the immobilizer system (i.e., steering lock or key fob docking station). The transmitter should be installed at minimum 15 cm away from any possible layoff of the key fob, handbag or driver pockets. Ideal position is a vertical position on the dashboard.

Additional counter measures
If the above mentioned safe recommended distances (4.1.1) can't be achieved, other techniques are recommended to be used to avoid interference with the key fob.

- The charger installation and use instructions notes that the driver should insert the key fob into the charging slot whenever possible when operating the wireless charger.
- Charger should only be powered with "accessories" and/or "engine on" (can't be applied with permanent powered cigarette lighters).
- To have some margin in timing between key fob authentication and contact/engine on, the charger should wait a minimum of one second before starting charge.

With these measures the engine start and car lock problems can be avoided. Door opening or key fob polling with running engine remain a risk.



CE "Hereby, Annex products declares that this product is in compliance with Directive 2014/53/EU. The full text of the EU declaration of conformity can be found at www.quadlock.com.au/compliance."

INDUSTRIE CANADA (IC: 27134-QLAWCH3)
This device complies with Industry Canada's license-exempt RSSs. Operation is subject to the following two conditions:

- This device may not cause interference; and
- This device must accept any interference, including interference that may cause undesired operation of the device.

This equipment complies with Canada radiation exposure limits set forth for an uncontrolled environment.

During the operation of device a distance of 10 cm surrounding the device and 10 cm above the top surface of the device must be respected.

Le présent appareil est conforme aux CNR d'Industrie Canada applicables aux appareils radio exempts de licence. L'exploitation est autorisée aux deux conditions suivantes:

- L'appareil ne doit pas produire de brouillage;
- L'utilisateur de l'appareil doit accepter tout brouillage radioélectrique subi, même si le brouillage est susceptible d'en compromettre le fonctionnement.

Cet équipement est conforme Canada limites d'exposition aux radiations dans un environnement non contrôlé.

Au cours de l'opération de l'appareil sur une distance de 10 cm autour de l'appareil et de 10 cm au-dessus de la surface supérieure de l'appareil doit être respecté.

WWW.QUADLOCKCASE.NET



HEAD
WIRELESS CHARGING

Qi CERTIFIED FAST CHARGING
5w|7.5w|10w

