

User Manual

1. Product parameter

| | | |
|---|--|-----|
| Wireless charging Compatible protocol Output Power | QI-BPP agreement | 5W |
| | Samsung Fast Charge Agreement | 10W |
| Input voltage | DC29V | |
| Protect function | Over temperature protection, FOD foreign object detection | |
| Indicator light instruction | 1. Standby state: the indicator light is not lit 2. Charging status: indicator light is green 3. If there is any abnormality such as foreign matter during over-temperature and wireless charging, the indicator light will flash green. | |
| USB instruction | Maximum output 5V/2A, support USB charging and wireless charging at the same time. | |
| Working temperature | 0-35°C | |

2. System configuration

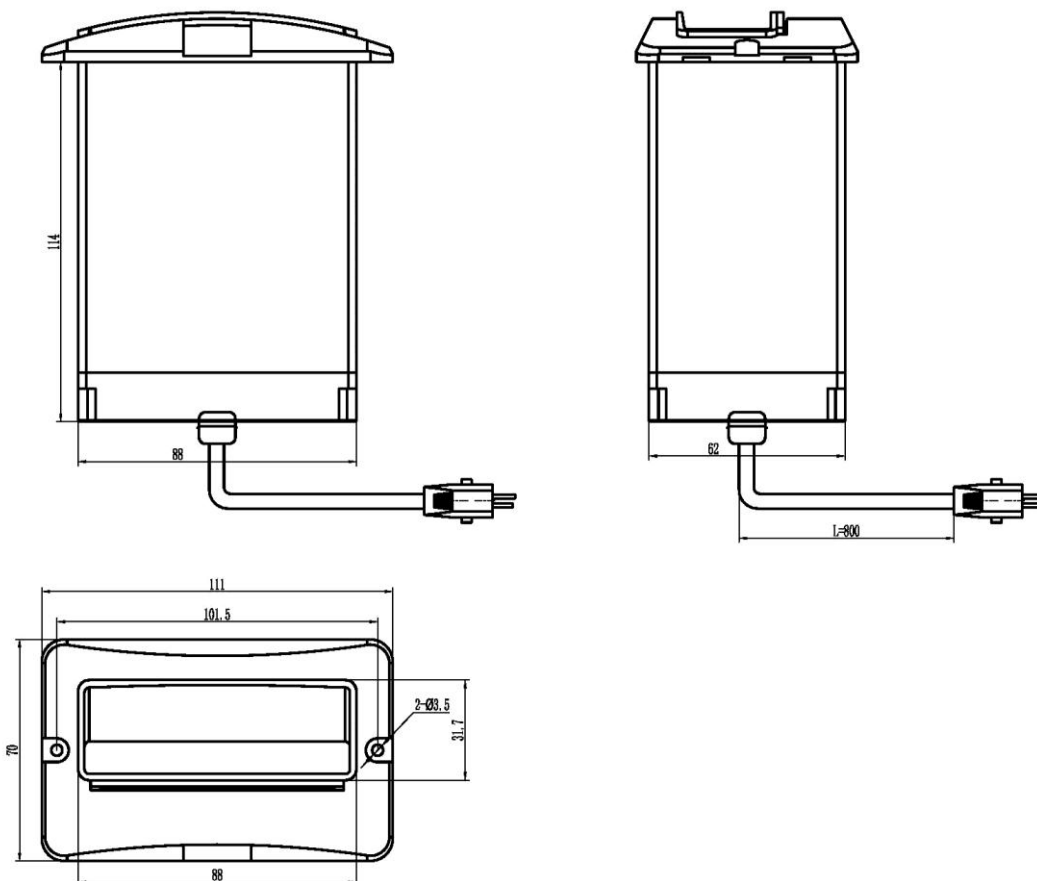

3.Instructions

I. Provide wireless charging DC29V power supply through a dedicated power adapter. Once powered, you can start working properly.

II. Put the mobile phone with wireless charging function (such as iPhone8/8plus/X, Samsung Note8/S9+, Huawei mate20Pro, etc.) into the wireless charging slot, and the charging will start automatically. When the wireless charger is in normal working condition, the LED green light is always on.

III. When charging, you need to keep the center position of the phone aligned with the center position of the wireless charger to perform wireless charging. Phone put to the side of slot will cause low efficient charging or cannot charge. If it is not working properly, please adjust the position of the phone until the phone shows normal charging or the LED is steady green. (please refer to the position shown below)

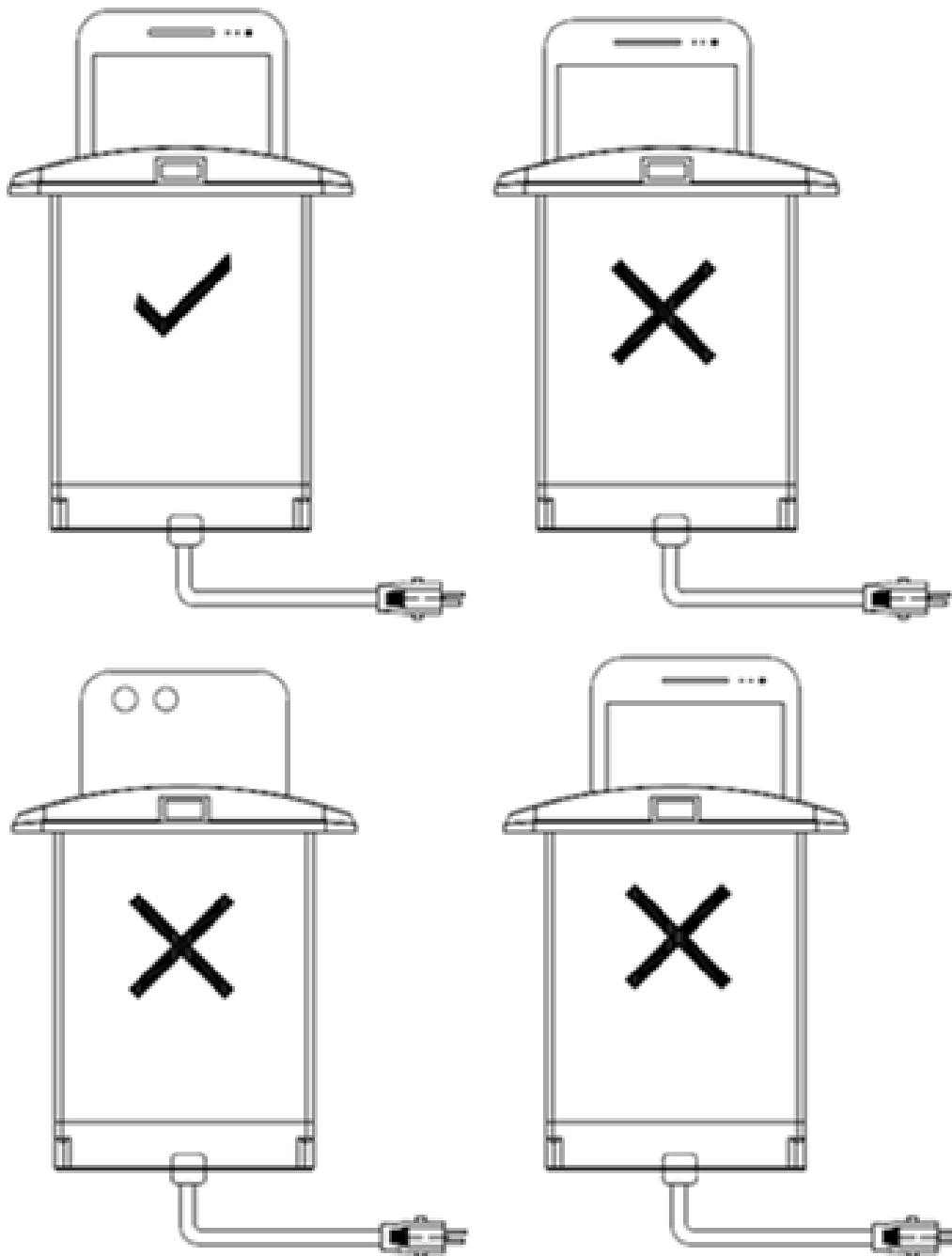

4. Notes

- Do not mix metal foreign objects between the phone and the wireless charger while charging.
- In order to ensure normal charging, the thickness of the plastic or silicone mobile phone case is less than 1-2mm. The material and thickness of the phone case can affect the normal charging function and increase the temperature of the wireless charging. If necessary, remove the phone case for wireless charging.
- Do not squeeze or bump the product.
- Do not disassemble or modify it by yourself.
- Do not place the product near fire or into fire or water.
- Do not use the wireless charger under severe heat, humidity or corrosive conditions to avoid damage to the circuit.
- Do not place the magnetic card (ID card, bank card, etc.) with a magnetic strip or chip too close to avoid the magnetic card failure.
- Keep implanted medical devices (cardiac pacemakers, implantable cochlea, etc.) at least 20 cm away from the wireless charger to avoid potential interference with medical equipment.
- Children should be taken care to avoid unnecessary accidents.
- Warranty period: 1 year.

FCC Statement

Any Changes or modifications not expressly approved by the party responsible for compliance could void the user's authority to operate the equipment. This device complies with part 15 of the FCC Rules. Operation is subject to the following two conditions: (1) This device may not cause harmful interference, and (2) This device must accept any interference received, including interference that may cause undesired operation.

FCC Radiation Exposure Statement:

This equipment complies with FCC radiation exposure limits set forth for an uncontrolled environment. This equipment should be installed and operated with minimum distance 20cm between the radiator & your body.

Note: This equipment has been tested and found to comply with the limits for a Class B digital device, pursuant to part 15 of the FCC Rules. These limits are designed to provide reasonable protection against harmful interference in a residential installation. This equipment generates, uses and can radiate radio frequency energy and, if not installed and used in accordance with the instructions, may cause harmful interference to radio communications. However, there is no guarantee that interference will not occur in a particular installation. If this equipment does cause harmful interference to radio or television reception, which can be determined by turning the equipment off and on, the user is encouraged to try to correct the interference by one or more of the following measures:

- Reorient or relocate the receiving antenna.
- Increase the separation between the equipment and receiver.
- Connect the equipment into an outlet on a circuit different from that to which the receiver is connected.
- Consult the dealer or an experienced radio/TV technician for help.