

WIRELESS INPUT UNIT (Modbus-RTU Transparent 900MHz Band Wireless Device (Child device), Built-in I/O, 2-wire Transmitter Inputs 2 points)	MODEL WL40W1F-DS2
--	--------------------------

BEFORE USE

Thank you for choosing M-System. Before use, please check contents of the package you received as outlined below. If you have any problems or questions with the product, please contact M-System's Sales Office or representatives.

■ PACKAGE INCLUDES:

Wireless input unit(1)
 Antenna(1)

■ MODEL NO.

Confirm Model No. marking on the product to be exactly what you ordered.

■ INSTRUCTION MANUAL

This manual describes necessary points of caution when you use this product, including installation, connection, hardware setting, and basic maintenance procedures. For information on the introduction of wireless device, refer to the 900MHz band wireless device operating manual (EM-9085).

POINTS OF CAUTION

■ POWER INPUT RATING & OPERATIONAL RANGE

- Locate the power input rating marked on the product and confirm its operational range as indicated below:
 24 V DC rating: 24 V ±10%, ≤ 140 mA

■ GENERAL PRECAUTIONS

- Before you remove the unit or mount it, turn off the power supply for safety.

■ ENVIRONMENT

- Indoor use.
- When heavy dust or metal particles are present in the air, install the unit inside proper housing with sufficient ventilation.
- Do not install the unit where it is subjected to continuous vibration. Do not subject the unit to physical impact.
- Environmental temperature must be within -10 to +55°C (14 to 131°F) with relative humidity within 10 to 90% RH in order to ensure adequate life span and operation.
- Attach the antenna to the unit.
- Attachment and adjustment of sleeve antenna; Loosen the connector (See the top-right figure.), and rotate the antenna. Holding the antenna vertical, tighten the connector by hand.
- Make sure to fix the antenna firmly.

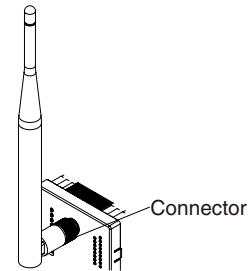

- Attachment of rooftop antenna; There is a magnet on the bottom face which allows you to attach the antenna on a metal box and such. To obtain optimum performance from the antenna, attach on a metal plate (recommended dimension: 500 mm × 500 mm or more). However, in the case of connecting FE1 to a metal plate, the isolation between FE1 and antenna connector will be lost. Tighten the connector with a specified torque (0.9 N·m). As a guide, finger-tighten it until the connector stops, and then rotate it 10 to 15 degrees with a wrench. Do not force the cable to bend less than acceptable radius of 3 cm.
- Using 7.5 m coaxial cable (model: CX-SAC0SAD0Q0750) (OKI) for extension decreases transmission distance.

■ WIRING

- Do not install cables close to noise sources (relay drive cable, high frequency line, etc.).
- Do not bind these cables together with those in which noises are present. Do not install them in the same duct.

■ AND

- The unit is designed to function as soon as power is supplied, however, a warm up for 10 minutes is required for satisfying complete performance described in the data sheet.

CAUTION REGARDING RADIO FREQUENCY

■ FCC NOTICE

- This device complies with part 15 of the FCC Rules. Operation is subject to the following two conditions: (1) This device may not cause harmful interference, and (2) this device must accept any interference received, including interference that may cause undesired operation.

■ FCC CAUTION

- Changes or modifications not expressly approved by the party responsible for compliance could void the user's authority to operate the equipment.

■ NOTE

- This equipment has been tested and found to comply with the limits for a Class A digital device, pursuant to part 15 of the FCC Rules. These limits are designed to provide reasonable protection against harmful interference when the equipment is operated in a commercial environment. This equipment generates, uses, and can radiate radio frequency energy and, if not installed and used in accordance with the instruction manual, may cause harmful interference to radio communications. Operation of this equipment in a residential area is likely to cause harmful interference in which case the user will be required to correct the interference at his own expense.
- This transmitter must not be co-located or operated in conjunction with any other antenna or transmitter.

■ FCC RF EXPOSURE INFORMATION

- This equipment complies with FCC radiation exposure limits set forth for an uncontrolled environment and meets the FCC radio frequency (RF) Exposure Guidelines. This equipment should be installed and operated keeping the radiator at least 20cm or more away from person's body.

FCC ID : 2AOTF-0000004

Contains FCC ID: 2AKGW-1TD3016A1

COMPONENT IDENTIFICATION

■ FRONT VIEW

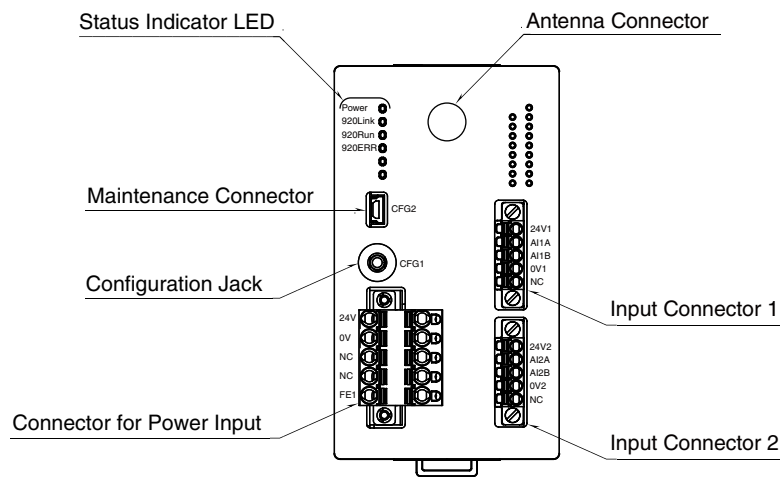

■ STATUS INDICATOR LED

ID	STATUS	COLOR	FUNCTION
Power	ON	Green	Power is on.
920Link	ON	Green	Wireless: coordinator is connected
	0.5 Hz blinking	Green	Wireless: coordinator connection is in process
	Blinking twice per second	Green	Wireless: start-up error
920Run	ON	Green	Wireless: normal communication
920ERR	ON	Red	No detour
	Blinking	Red	Network authentication failure

■ **TERMINAL ASSIGNMENTS**

• **Connector for power input**

Unit side connector: MSTBV2,5/5-GF-5,08AU (Phoenix Contact)

Cable side connector: TFKC2,5/5-STF-5,08AU (Phoenix Contact)

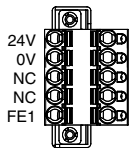

ID	FUNCTION
24V	Power input 24 V
0V	Power input 0 V
NC	Not used
NC	Not used
FE1	Power input earth

• **Input connector 1**

Unit side connector: MC1,5/5-GF-3,5 (Phoenix Contact)

Cable side connector: FMC1,5/5-STF-3,5 (Phoenix Contact)



ID	FUNCTION
24V1	2-wire transmitter 1 +
AI1A	2-wire transmitter 1 -
AI1B	Current input 1 +
0V1	Current input 1 -
NC	Not used

• **Input connector 2**

Unit side connector: MC1,5/5-GF-3,5 (Phoenix Contact)

Cable side connector: FMC1,5/5-STF-3,5 (Phoenix Contact)

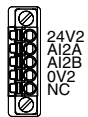

ID	FUNCTION
24V2	2-wire transmitter 2 +
AI2A	2-wire transmitter 2 -
AI2B	Current input 2 +
0V2	Current input 2 -
NC	Not used

CONFIGURATOR SOFTWARE SETTING

With configurator software, settings shown below are available.
Refer to the users manual of W920FCFG for detailed operation.

■ WIRELESS SETTING

ITEM	SETTING RANGE	DEFAULT
Preferred PAN ID (group number)	0000 – FFFE (hexadecimal, 4 digits)	0000
Radio channel number	1 – 43 (selectable up to 10 channels)	None
Short address	0000 – FFFD (hexadecimal, 4 digits)	0000
Network name	English one-byte characters within 16 characters (one-byte space, “-”, “_”, “.”, “@” are usable.)	Blank
Encryption key	0000...0 – FFFF...F (hexadecimal, 32 digits)	0000...0
Transmitter power output	0.16mW / 1mW / 20mW	20mW
Low-speed moving mode	No / Yes	No
Device type in a network, Number of devices in a network	Child (fixed), 1 to 30 devices / Child (fixed), 31 to 60 devices / Child (fixed), 61 to 100 devices / Child (fixed) + child (moving)	Child (fixed), 1 to 30 devices
Set network quality	Standard (recommended) / Frequency of route switching and delay (higher) / Frequency of route switching and delay (highest)	Standard (recommended)
Network join mode	V3-compatible mode / Fast join mode	V3-compatible mode
Fixed route	No / Yes	No
Destination short address	0000 – FFFD (hexadecimal, 4 digits)	0000
Temporary detour	No / Yes	Yes
Packet filtering	None / Yes (polling type)	Yes (polling type)
Filter timeout on polling	1.0 – 60.0 (sec.)	1.0 (sec.)
920Run timeout	1.0 – 60.0 (sec.)	3.0 (sec.)
Modbus node address	1 – 247	1
Retry times before route switching	Once / Twice / Three times	Three times

* For version confirmation of communication module, refer to the users manual of W920FCFG.

■ INPUT SETTING

CHANNEL	ITEM	SETTING RANGE	DEFAULT
Analog input 1	Input enabled / disabled	Enabled / Disabled	Enabled
	Zero input value	4.000 – 20.000	4.000 (mA)
	Full input value	4.000 – 20.000 (full input value > zero input value)	20.000 (mA)
	Fine zero adjustment	-5.00 – +5.00 (%)	0.00 (%)
	Fine gain adjustment	0.9500 – 1.0500	1.0000
	Zero scaling value	-32000 – +32000	0
	Full scaling value	-32000 – +32000	10000
	First-order filter time constant	0.0 – 60.0 (sec.)	0.0 (sec.)
Analog input 2	Input enabled / disabled	Enabled / Disabled	Enabled
	Zero input value	4.000 – 20.000	4.000 (mA)
	Full input value	4.000 – 20.000 (full input value > zero input value)	20.000 (mA)
	Fine zero adjustment	-5.00 – +5.00 (%)	0.00 (%)
	Fine gain adjustment	0.9500 – 1.0500	1.0000
	Zero scaling value	-32000 – +32000	0
	Full scaling value	-32000 – +32000	10000
	First-order filter time constant	0.0 – 60.0 (sec.)	0.0 (sec.)

INSTALLATION

■ DIN RAIL MOUNTING

- A) Hang the upper hook at the back of the unit on the DIN rail.
- B) Push the lower part of the unit to fit in the DIN rail.

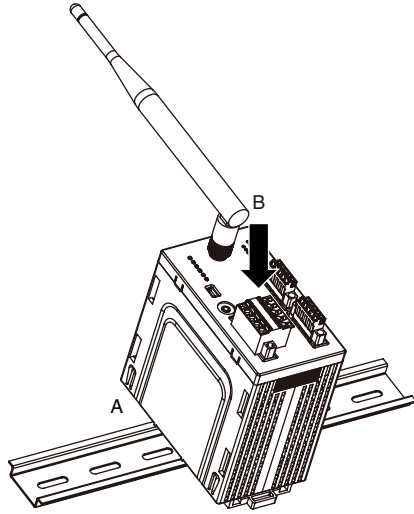

■ DEMOUNTING

- A) Pull down the DIN rail adaptor using a minus screwdriver.
- B) Pull out the lower part of the unit.
- C) Remove the upper part from the DIN rail.

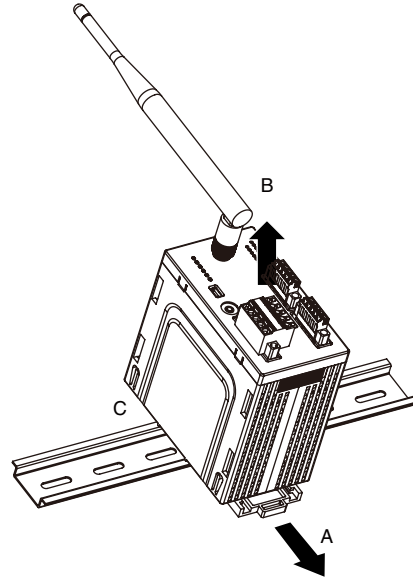

TERMINAL CONNECTIONS

Connect the unit as in the diagram below.

EXTERNAL DIMENSIONS unit: mm (inch)

WITH SLEEVE ANTENNA

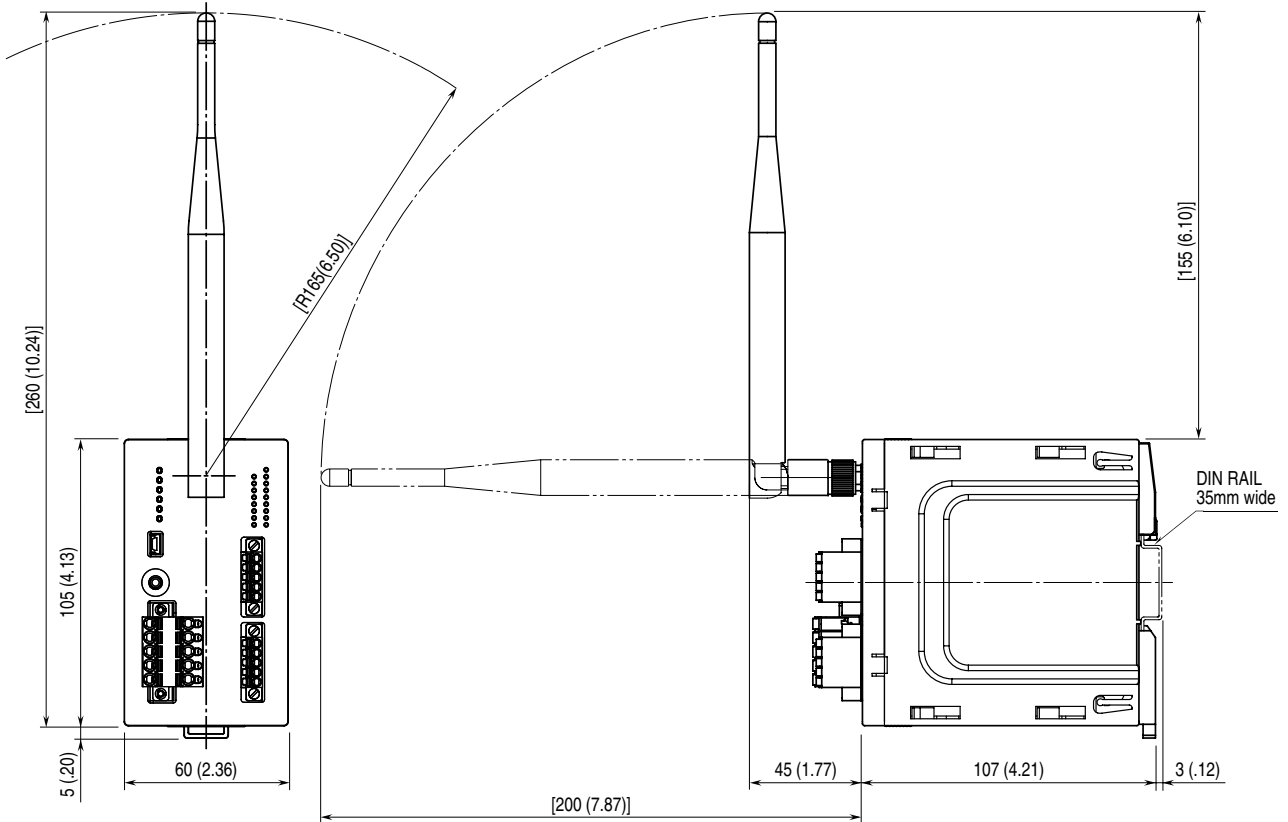

WITH ROOFTOP ANTENNA

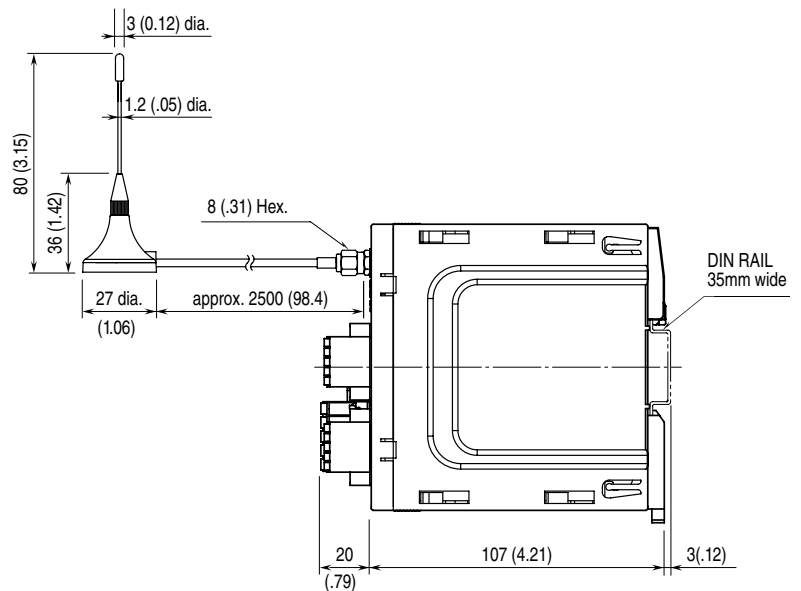

■ CONNECTION DIAGRAM

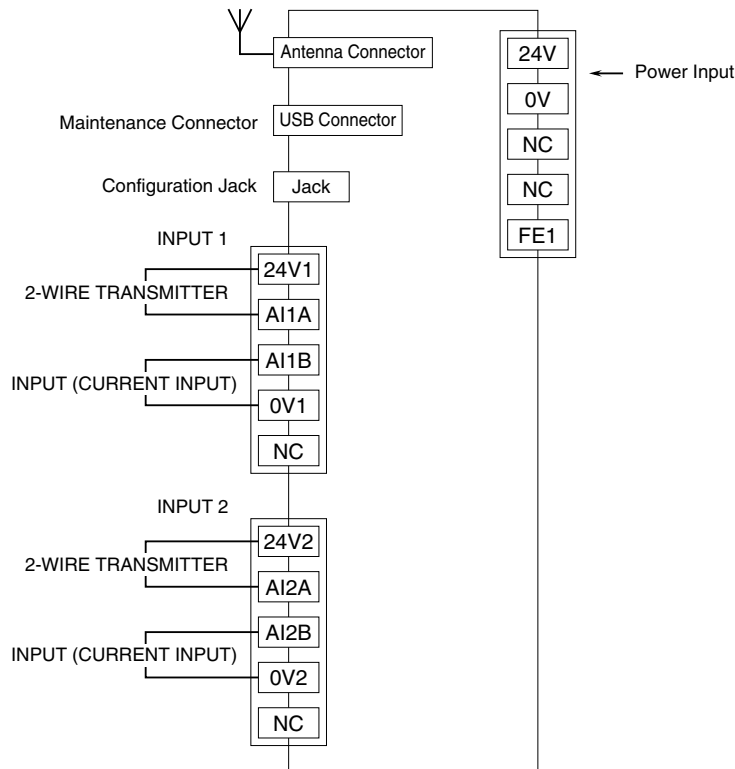

■ HANDLING OF THE UNUSED INPUT

Connect 5 kΩ (0.5 W) terminating resistor to the input terminal which is not used, as shown below.

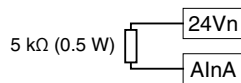

If the above step is not performed, input becomes -5% or less, and PLC and such show data error. However, using PC configuration software (model: W920FCFG) enables the setting of the unused input without the above step.

WIRING INSTRUCTIONS

■ TENSION CLAMP (FRONT TWIN CONNECTION) FOR POWER INPUT

Applicable wire size: 0.2 to 2.5 mm²

Stripped length: 10 mm

Recommended terminals:

AI0,25-10YE	0.25 mm ² (Phoenix Contact)
AI0,34-10TQ	0.34 mm ² (Phoenix Contact)
AI0,5-10WH	0.5 mm ² (Phoenix Contact)
AI0,75-10GY	0.75 mm ² (Phoenix Contact)
AI1-10RD	1.0 mm ² (Phoenix Contact)
AI1,5-10BK	1.5 mm ² (Phoenix Contact)
AI2,5-10BU	2.5 mm ² (Phoenix Contact)

■ SEPARABLE TENSION CLAMP TERMINAL FOR INPUT

Applicable wire size: 0.2 to 1.5 mm²

Stripped length: 10 mm

Recommended terminals:

AI0,25-10YE	0.25 mm ² (Phoenix Contact)
AI0,34-10TQ	0.34 mm ² (Phoenix Contact)
AI0,5-10WH	0.5 mm ² (Phoenix Contact)
AI0,75-10GY	0.75 mm ² (Phoenix Contact)

MODBUS FUNCTION CODE

Modbus function codes are shown below.

■ DATA AND CONTROL FUNCTION

CODE	NAME	
01	Read Coil Status	Digital output from the slave (read / write)
02	Read Input Status	Status of digital inputs to the slave (read only)
03	Read Holding Registers	General purpose register within the slave (read / write)
04	Read Input Registers	Collected data from the field by the slave (read only)
05	Force Single Coil	Digital output from the slave (read / write)
06	Preset Single Registers	General purpose register within the slave (read / write)
15	Force Multiple Coils	Digital output from the slave (read / write)
16	Preset Multiple Registers	General purpose register within the slave (read / write)

■ EXCEPTION CODE

CODE	NAME	
01	Illegal Function	Function code is not allowable for the slave
02	Illegal Data Address	Address is not available within the slave
03	Illegal Data Value	Data is not valid for the function
04	Slave Device Failure	
05	Acknowledge	
06	Slave Device Busy	
07	Negative Acknowledge	

MODBUS I/O ASSIGNMENT

	ADDRESS	DATA TYPE	DATA
Coil (0X)	1 – 16		Reserved (unused)
Input (1X)	1 – 8		Reserved (unused)
	9		Analog input error (input range error of analog input 1)
	10		Analog input error (input range error of analog input 2)
	11 – 16		Reserved (unused)
Input Register (3X)	1	I	Analog Input (analog input 1)
	2	I	Analog Input (analog input 2)
	3 – 16	–	Reserved (unused)
	16	–	Reserved (unused)
Holding Register (4X)	1 – 16	–	Reserved (unused)

Note: DO NOT access addresses other than mentioned above. Such access may cause problems such as inadequate operation.

■ DATA TYPE

I: Integer -32768 – +32767

■ STATUS

1 bit: indicates input status.

Input range error (Input range is out of the range -5 to +105% for scaling setting, or out of the range -32768 to +32767 .)

0: Normal 1: Error

INPUT DATA

■ ANALOG DATA (16 BITS)

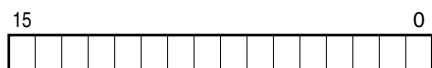

When the scaling setting is initial value, the data is 0 to 10000 for input 0 to 100% setting.
If the input range is -5 to +105% (-500 to +10500) and that is out of range, the data is fixed to -500 or 10500.
Minus value is converted into negative values, represented in 2's complements.

■ DATA ERROR STATUS

Data error status is indicated by 1 bit.

0: OFF 1: ON

LIGHTNING SURGE PROTECTION

M-System offers a series of lightning surge protector for protection against induced lightning surges. Please contact M-System to choose appropriate models.