



# EMI TEST REPORT

**Test Report No. : 12208121H-A-R1**

**Applicant** : M-SYSTEM CO., LTD.  
**Type of Equipment** : WIRELESS I/O UNIT  
**Model No.** : WL40W1F-DAC4A  
**FCC ID** : 2AOTF-0000003  
**Test regulation** : FCC Part 15 Subpart B: 2018 Class A  
**Test Result** : Complied

1. This test report shall not be reproduced in full or partial, without the written approval of UL Japan, Inc.
2. The results in this report apply only to the sample tested.
3. This sample tested is in compliance with the above regulation.
4. The test results in this report are traceable to the national or international standards.
5. This test report covers EMC technical requirements. It does not cover administrative issues such as Manual or non-EMC test related Requirements. (if applicable)
6. The all test items in this test report are conducted by UL Japan, Inc. Ise EMC Lab.
7. This test report must not be used by the customer to claim product certification, approval, or endorsement by NVLAP, NIST, or any agency of the Federal Government.
8. This report is a revised version of 12208121H-A. 12208121H-A is replaced with this report.

**Date of test:** May 10, 2018

**Representative test engineer:**

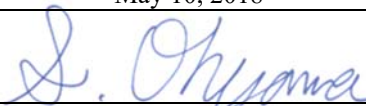

Shuichi Ohyama  
Engineer

Consumer Technology Division

**Approved by:**



Satofumi Matsuyama  
Engineer

Consumer Technology Division

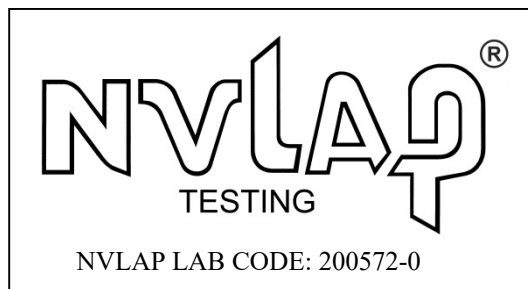

This laboratory is accredited by the NVLAP LAB CODE 200572-0, U.S.A. The tests reported herein have been performed in accordance with its terms of accreditation.  
\*As for the range of Accreditation in NVLAP, you may refer to the WEB address,  
[http://japan.ul.com/resources/emc\\_accredited/](http://japan.ul.com/resources/emc_accredited/)

- The testing in which "Non-accreditation" is displayed is outside the accreditation scopes in UL Japan.  
 There is no testing item of "Non-accreditation".

**UL Japan, Inc.**

**Ise EMC Lab.**

4383-326 Asama-cho, Ise-shi, Mie-ken 516-0021 JAPAN

Telephone : +81 596 24 8999

Facsimile : +81 596 24 8124

13-EM-F0429



<b>CONTENTS</b>	<b>PAGE</b>
<b>SECTION 1: Customer information.....</b>	<b>4</b>
<b>SECTION 2: Equipment under test (E.U.T.).....</b>	<b>4</b>
<b>SECTION 3: Test specification, procedures &amp; results.....</b>	<b>5</b>
<b>SECTION 4: Operation of E.U.T. during testing.....</b>	<b>8</b>
<b>SECTION 5: Conducted Emission.....</b>	<b>10</b>
<b>SECTION 6: Radiated Emission.....</b>	<b>11</b>
<b>APPENDIX 1: Test data .....</b>	<b>12</b>
Conducted Emission .....	12
Radiated emission .....	14
<b>APPENDIX 2: Test instruments .....</b>	<b>18</b>
<b>APPENDIX 3: Photographs of test setup .....</b>	<b>19</b>
Conducted Emission .....	19
Radiated Emission.....	21
Worst Case Position .....	25

---

**UL Japan, Inc.**

**Ise EMC Lab.**

4383-326 Asama-cho, Ise-shi, Mie-ken 516-0021 JAPAN

Telephone : +81 596 24 8999

Facsimile : +81 596 24 8124

## **SECTION 1: Customer information**

Company Name : M-SYSTEM CO., LTD.  
Address : 5-2-55 MINAMITSUMORI, NISHINARI-KU, OSAKA, 557-0063  
JAPAN  
Telephone Number : +81-6-6659-8258  
Facsimile Number : +81-6-6659-8514  
Contact Person : Juri Sugiyama

## **SECTION 2: Equipment under test (E.U.T.)**

### **2.1 Identification of E.U.T.**

Type of Equipment : WIRELESS I/O UNIT  
Model No. : WL40W1F-DAC4A  
Serial No. : Refer to Section 4, Clause 4.2  
Rating : DC 12 V (WL40W1F-DAC4A-S)  
DC 24 V (WL40W1F-DAC4A-R)  
Receipt Date of Sample : May 8, 2018  
Country of Mass-production : Japan  
Condition of EUT : Engineering prototype  
(Not for Sale: This sample is equivalent to mass-produced items.)  
Modification of EUT : No Modification by the test lab

### **2.2 Product Description**

Model: WL40W1F-DAC4A (referred to as the EUT in this report) is a WIRELESS I/O UNIT.

#### **General Specification**

Clock frequency(ies) in the system : 80 MHz (max.)

#### **Radio Specification**

	IEEE802.15.4g
Frequency of operation	902 MHz - 928 MHz
Type of modulation	GFSK
Channel spacing	0.6 MHz
Antenna type	sleeve antenna (model: MH920-ANT-F(S)) rooftop antenna (model: MH920-ANT-F(R))
Antenna Connector type	Connector for connecting antenna
Antenna Gain	3 dBi (max) (sleeve antenna) 2 dBi (max) (rooftop antenna)
Clock frequency (maximum)	928 MHz

\* WL40W1F-DAC4A has following two types;

	Power input voltage
WL40W1F-DAC4A-S	DC 12 V
WL40W1F-DAC4A-R	DC 24V

\* The RF module is a FCC certificated module made by Oki Electric Industry Co., Ltd. Model number: MH920-Mod-F (FCC ID: 2AKGW-1TD3016A1).

**UL Japan, Inc.**

**Ise EMC Lab.**

4383-326 Asama-cho, Ise-shi, Mie-ken 516-0021 JAPAN

Telephone : +81 596 24 8999

Facsimile : +81 596 24 8124

## **SECTION 3: Test specification, procedures & results**

### **3.1 Test Specification**

Test Specification : FCC Part 15 Subpart B  
FCC Part 15 final revised on March 12, 2018 and effective April 11, 2018

Title : FCC 47CFR Part15 Radio Frequency Device  
Subpart B Unintentional Radiators

### **3.2 Procedures and results**

Item	Test Procedure	Limits	Deviation	Worst margin	Result
Conducted emission	FCC: ANSI C63.4: 2014 7. AC power - line conducted emission measurements ----- IC: ICES-003 Issue 6: 2016 + Amendment 1: 2017	Class A	N/A	[QP] 30.2 dB 20.62321 MHz, N (WL40W1F-DAC4A-R) [AV] 21.4 dB 20.62321 MHz, N (WL40W1F-DAC4A-R)	Complied
Radiated emission	FCC: ANSI C63.4: 2014 8. Radiated emission measurements ----- IC: ICES-003 Issue 6: 2016 + Amendment 1: 2017	Class A	N/A	12.6 dB 454.779 MHz, QP Horizontal (WL40W1F-DAC4A-S)	Complied

\*Note: UL Japan, Inc's EMI Work Procedure 13-EM-W0420.

Symbols:

Complied The data of this test item has enough margin, more than the measurement uncertainty.

Complied# The data of this test item meets the limits unless the measurement uncertainty is taken into consideration.

### **3.3 Addition to standard**

No addition, exclusion nor deviation has been made from the standard.

**UL Japan, Inc.**

**Ise EMC Lab.**

4383-326 Asama-cho, Ise-shi, Mie-ken 516-0021 JAPAN

Telephone : +81 596 24 8999

Facsimile : +81 596 24 8124

### 3.4 Uncertainty

#### EMI

The following uncertainties have been calculated to provide a confidence level of 95 % using a coverage factor  $k = 2$ .

#### Conducted emission

using Item	Frequency range	Uncertainty (+/-)
AMN (LISN)	0.009 MHz to 0.15 MHz	3.8 dB
	0.15 MHz to 30 MHz	3.4 dB

#### Radiated emission

Measurement distance	Frequency range	Uncertainty (+/-)	
10 m	30 MHz to 200 MHz	(Horizontal)	4.8 dB
		(Vertical)	4.9 dB
	200 MHz to 1000 MHz	(Horizontal)	5.0 dB
		(Vertical)	5.0 dB
3 m	1 GHz to 6 GHz	5.0 dB	
	6 GHz to 18 GHz	5.3 dB	

### 3.5 Test Location

UL Japan, Inc. Ise EMC Lab.  
4383-326 Asama-cho, Ise-shi, Mie-ken 516-0021 JAPAN  
Telephone: +81 596 24 8999, Facsimile: +81 596 24 8124  
NVLAP Lab. code: 200572-0 / FCC Test Firm Registration Number: 199967

Test site	IC Registration Number	Width x Depth x Height (m)	Size of reference ground plane (m) / horizontal conducting plane	Other rooms	Maximum measurement distance
No.1 semi-anechoic chamber	2973C-1	19.2 x 11.2 x 7.7	7.0 x 6.0	No.1 Power source room	10 m
No.2 semi-anechoic chamber	2973C-2	7.5 x 5.8 x 5.2	4.0 x 4.0	-	3 m
No.3 semi-anechoic chamber	2973C-3	12.0 x 8.5 x 5.9	6.8 x 5.75	No.3 Preparation room	3 m
No.3 shielded room	-	4.0 x 6.0 x 2.7	N/A	-	-
No.4 semi-anechoic chamber	2973C-4	12.0 x 8.5 x 5.9	6.8 x 5.75	No.4 Preparation room	3 m
No.4 shielded room	-	4.0 x 6.0 x 2.7	N/A	-	-
No.5 semi-anechoic chamber	-	6.0 x 6.0 x 3.9	6.0 x 6.0	-	-
No.6 shielded room	-	4.0 x 4.5 x 2.7	4.0 x 4.5	-	-
No.6 measurement room	-	4.75 x 5.4 x 3.0	4.75 x 4.15	-	-
No.7 shielded room	-	4.7 x 7.5 x 2.7	4.7 x 7.5	-	-
No.8 measurement room	-	3.1 x 5.0 x 2.7	N/A	-	-
No.9 measurement room	-	8.8 x 4.6 x 2.8	2.4 x 2.4	-	-
No.11 measurement room	-	6.2 x 4.7 x 3.0	4.8 x 4.6	-	-

\* Size of vertical conducting plane (for Conducted Emission test) : 2.0 m x 2.0 m for No.1, No.2, No.3, and No.4 semi-anechoic chambers and No.3 and No.4 shielded rooms.

### 3.6 Test data, Test instruments, and Test set up

Refer to APPENDIX.

## SECTION 4: Operation of E.U.T. during testing

### 4.1 Operating Mode(s)

Mode	Remarks
1) Communication mode	- 920 MHz band wireless communication - wired communication with Terminal Block

### 4.2 Configuration and peripherals

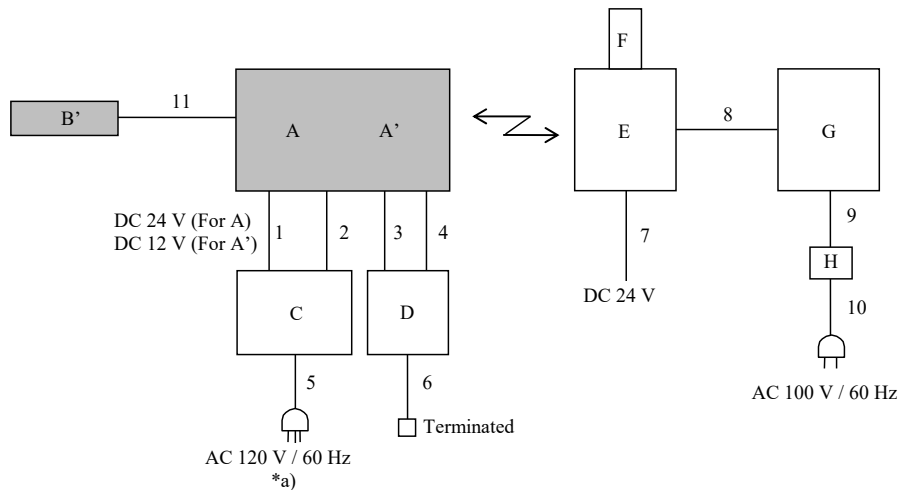
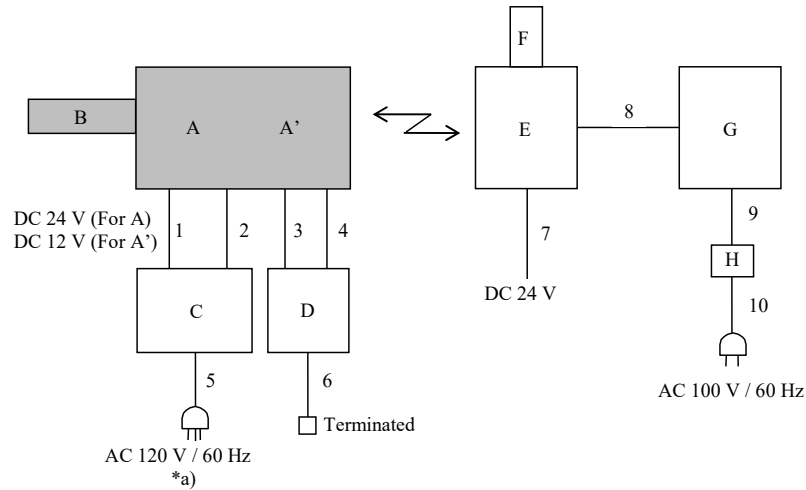

\* Cabling and setup(s) were taken into consideration and test data was taken under worse case conditions.

\*a) Conducted emission test was performed on this port



**Description of EUT and Support equipment**

No.	Item	Model number	Serial number	Manufacturer	Remarks
A	WIRELESS I/O UNIT	WL40W1F-DAC4A-R	P-34969	M-SYSTEM CO., LTD.	EUT
A'	WIRELESS I/O UNIT	WL40W1F-DAC4A-S	P-34968	M-SYSTEM CO., LTD.	EUT
B	sleeve antenna	MH920-ANT-F(S)	001	OKI	-
B'	rooftop antenna	MH920-ANT-F(R)	001	OKI	-
C	DC Power Supply	PMC35-2A	13090501	KIKUSUI	*1)
D	Terminal Block	-	-	-	-
E	Wireless Gateway	WL40EW2F-R	P-34762	M-SYSTEM CO., LTD.	-
F	Sleeve antenna	MH920-ANT-F(S)	-	OKI	-
G	Laptop PC	2672-C2J	99-PPBKH	IBM	-
H	AC Adapter	08K8212	11S08K8212Z1Z7 UB4160FD	IBM	-

\*1) Used for Conducted Emission test only

**List of cables used**

No.	Name	Length (m)	Shield		Remarks
			Cable	Connector	
1	DC Cable	1.0	Unshielded	Unshielded	-
2	Earth cable	1.0	Unshielded	Unshielded	-
3	DC and Signal Cable	1.0	Unshielded	Unshielded	-
4	Signal Cable	1.0	Unshielded	Unshielded	-
5	AC Cable	1.5	Unshielded	Unshielded	*1)
6	Signal Cable	0.2	Unshielded	Unshielded	-
7	DC Cable	1.5	Unshielded	Unshielded	-
8	LAN Cable	3.0	Shielded	Shielded	-
9	DC Cable	1.8	Unshielded	Unshielded	-
10	AC Cable	0.9	Unshielded	Unshielded	-
11	Antenna Cable	2.5	Shielded	Shielded	-

\*1) Used for Conducted Emission test only

**UL Japan, Inc.**

**Ise EMC Lab.**

4383-326 Asama-cho, Ise-shi, Mie-ken 516-0021 JAPAN

Telephone : +81 596 24 8999

Facsimile : +81 596 24 8124

## **SECTION 5: Conducted Emission**

### **5.1 Operating environment**

Test place : No.1 semi anechoic chamber  
Temperature : See data  
Humidity : See data

### **5.2 Test configuration**

EUT was placed on a urethane platform of nominal size, 1.0 m by 1.5 m, raised 0.8 m above the conducting ground plane. The rear of tabletop was located 40 cm to the vertical conducting plane. The rear of EUT and its peripherals was aligned and flushed with rear of tabletop. All other surfaces of tabletop were at least 80 cm from any other grounded conducting surface. EUT was located 80 cm from the LISN/AMN and excess AC cable was bundled in center. I/O cables that were connected to the other peripherals were bundled in center. They were folded back and forth forming a bundle 30 cm to 40 cm long and were hanged at a 40 cm height to the ground plane. Each EUT current-carrying power lead, except the ground (safety) lead, was individually connected through a LISN/AMN to the input power source. All unused 50 ohm connectors of the LISN/AMN were resistivity terminated in 50 ohm when not connected to the measuring equipment. Photographs of the set up are shown in Appendix 3.

Frequency range : 0.15 MHz - 30 MHz  
EUT position : Table top  
EUT operation mode : See Clause 4.1

### **5.3 Test procedure**

The AC Mains Terminal Continuous disturbance Voltage has been measured with the EUT within a semi anechoic chamber. The EUT was connected to a Line Impedance Stabilization Network (LISN)/ Artificial Mains network (AMN). An overview sweep with peak detection has been performed. The measurements have been performed with a quasi-peak detector and if required, with an average detector. The conducted emission measurements were made with the following detector function of the test receiver.

Detector Type : Quasi-Peak and CISPR AV  
IF Bandwidth : 9 kHz

### **5.4 Test result**

Summary of the test results: Pass

The test result is rounded off to one or two decimal places, so some differences might be observed.

Date: May 10, 2018 Test engineer: Shuichi Ohyama

## **SECTION 6: Radiated Emission**

### **6.1 Operating environment**

Test place : No.1 semi anechoic chamber  
Temperature : See data  
Humidity : See data

### **6.2 Test configuration**

EUT was placed on a urethane platform of nominal size, 1.0 m by 1.5 m, raised 0.8 m above the conducting ground plane. The EUT was set on the edge of the tabletop. Test was made with the antenna positioned in both the horizontal and vertical planes of polarization. The measurement antenna was varied in height above the conducting ground plane to obtain the maximum signal strength. Photographs of the set up are shown in Appendix 3.

### **6.3 Test conditions**

Frequency range : 30 MHz - 200 MHz (Biconical antenna) / 200 MHz - 1000 MHz (Logperiodic antenna)  
1000 MHz - 5000 MHz (Horn antenna)  
Test distance : 10 m (30 MHz - 1000 MHz) / 3 m (1000 MHz - 5000 MHz)  
EUT position : Table top  
EUT operation mode : See Clause 4.1

### **6.4 Test procedure**

The height of the measuring antenna varied between 1 and 4 m and EUT was rotated a full revolution in order to obtain the maximum value of the electric field intensity. The measurements were performed for both vertical and horizontal antenna polarization with the Test Receiver. The radiated emission measurements were made with the following detector function of the Test Receiver.

Frequency	Below 1GHz	Above 1GHz *1)
Instrument used	Test Receiver	Test Receiver
IF Bandwidth	QP: BW 120 kHz	PK: BW 1 MHz, CISPR AV: BW 1 MHz

\*1) The measurement data was adjusted to a 10 m distance using the following Distance Factor.  
Distance Factor:  $20 \times \log(3.8 \text{ m} / 10 \text{ m}) = -8.4 \text{ dB}$

The test was made on EUT at the normal use position.

### **6.5 Test result**

Summary of the test results: Pass

The limit is rounded down to one decimal place.  
The test result is rounded off to one or two decimal places, so some differences might be observed.

Date: May 10, 2018                      Test engineer: Shuichi Ohyama

**APPENDIX 1: Test data**

**Conducted Emission**

Report No. 12208121H  
Test place Ise EMC Lab.  
Semi Anechoic Chamber No.1  
Date May 10, 2018  
Temperature / Humidity 25 deg. C / 34 % RH  
Engineer Shuichi Ohyama  
Mode Mode 1 (WL40W1F-DAC4A-R)

LIMIT : FCC15.107(b) QP ClassA  
FCC15.107(b) AV ClassA

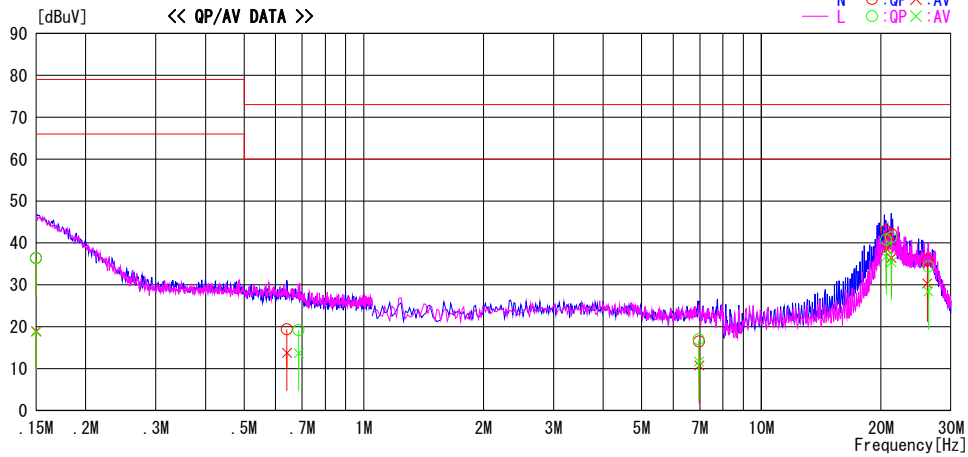

Frequency [MHz]	Reading Level		Corr. Factor [dB]	Results		Limit		Margin		Phase	Comment
	QP [dBuV]	AV [dBuV]		QP [dBuV]	AV [dBuV]	QP [dBuV]	AV [dBuV]	QP [dB]	AV [dB]		
0.15000	23.3	5.9	13.1	36.4	19.0	79.0	66.0	42.6	47.0	N	
0.64108	6.2	0.6	13.2	19.4	13.8	73.0	60.0	53.6	46.2	N	
6.97669	2.5	-3.2	14.0	16.5	10.8	73.0	60.0	56.5	49.2	N	
20.62321	28.0	23.8	14.8	42.8	38.6	73.0	60.0	30.2	21.4	N	
21.24368	27.2	21.5	14.9	42.1	36.4	73.0	60.0	30.9	23.6	N	
26.14516	20.7	15.2	15.1	35.8	30.3	73.0	60.0	37.2	29.7	N	
0.15000	23.3	5.7	13.1	36.4	18.8	79.0	66.0	42.6	47.2	L	
0.68627	6.0	0.5	13.2	19.2	13.7	73.0	60.0	53.8	46.3	L	
6.96076	3.0	-2.3	14.0	17.0	11.7	73.0	60.0	56.0	48.3	L	
20.60759	25.9	21.9	14.8	40.7	36.7	73.0	60.0	32.3	23.3	L	
21.21277	26.4	20.5	14.9	41.3	35.4	73.0	60.0	31.7	24.6	L	
26.30432	19.3	13.3	15.1	34.4	28.4	73.0	60.0	38.6	31.6	L	

CHART: WITH FACTOR Peak hold data. CALCULATION : RESULT = READING + C.F (LISN + CABLE + ATT)  
Except for the above table: adequate margin data below the limits.

## Conducted Emission

Report No. 12208121H  
Test place Ise EMC Lab.  
Semi Anechoic Chamber No.1  
Date May 10, 2018  
Temperature / Humidity 25 deg. C / 34 % RH  
Engineer Shuichi Ohyama  
Mode Mode 1 (WL40W1F-DAC4A-S)

LIMIT : FCC15.107(b) QP ClassA  
FCC15.107(b) AV ClassA

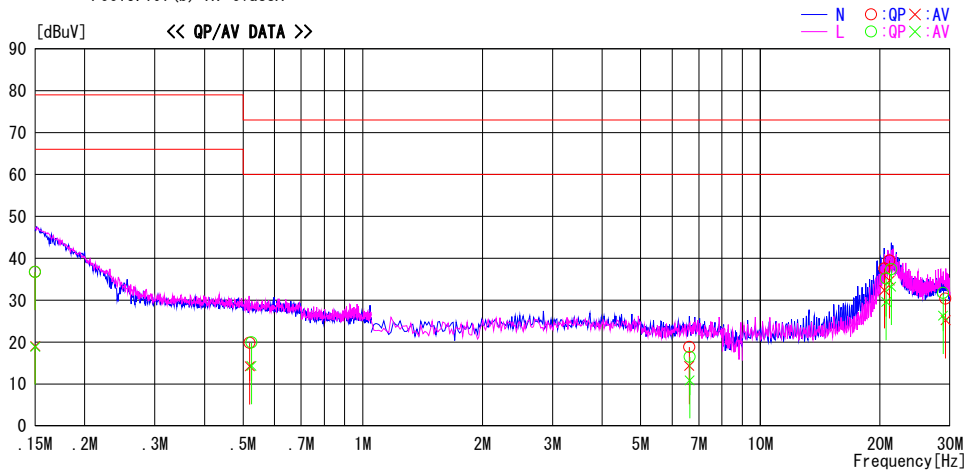

Frequency [MHz]	Reading Level		Corr. Factor [dB]	Results		Limit		Margin		Phase	Comment
	QP [dBuV]	AV [dBuV]		QP [dBuV]	AV [dBuV]	QP [dBuV]	AV [dBuV]	QP [dB]	AV [dB]		
0.15000	23.6	6.0	13.1	36.7	19.1	79.0	66.0	42.3	46.9	N	
0.51984	6.6	1.0	13.2	19.8	14.2	73.0	60.0	53.2	45.8	N	
6.62619	4.8	0.3	14.0	18.8	14.3	73.0	60.0	54.2	45.7	N	
20.51676	22.8	17.6	14.8	37.6	32.4	73.0	60.0	35.4	27.6	N	
21.13774	24.6	19.8	14.9	39.5	34.7	73.0	60.0	33.5	25.3	N	
29.21534	15.1	9.9	15.3	30.4	25.2	73.0	60.0	42.6	34.8	N	
0.15000	23.6	5.8	13.1	36.7	18.9	79.0	66.0	42.3	47.1	L	
0.52464	6.7	1.1	13.2	19.9	14.3	73.0	60.0	53.1	45.7	L	
6.64212	2.5	-3.1	14.0	16.5	10.9	73.0	60.0	56.5	49.1	L	
20.71394	20.4	14.8	14.8	35.2	29.6	73.0	60.0	37.8	30.4	L	
21.33824	22.5	18.3	14.9	37.4	33.2	73.0	60.0	35.6	26.8	L	
28.79320	16.5	11.1	15.2	31.7	26.3	73.0	60.0	41.3	33.7	L	

CHART: WITH FACTOR Peak hold data. CALCULATION : RESULT = READING + C.F (LISN + CABLE + ATT)  
Except for the above table: adequate margin data below the limits.

## Radiated emission

Report No. 12208121H  
Test place Ise EMC Lab.  
Semi Anechoic Chamber No.1  
Date May 10, 2018  
Temperature / Humidity 25 deg. C / 34 % RH  
Engineer Shuichi Ohyama  
(Below 1 GHz)  
Mode Mode 1 (WL40W1F-DAC4A-R)

LIMIT : FCC15.109(b)(subpart B class A) 10m, below 1GHz:QP, above 1GHz:PK  
Except for the data below : adequate margin data below the limits.

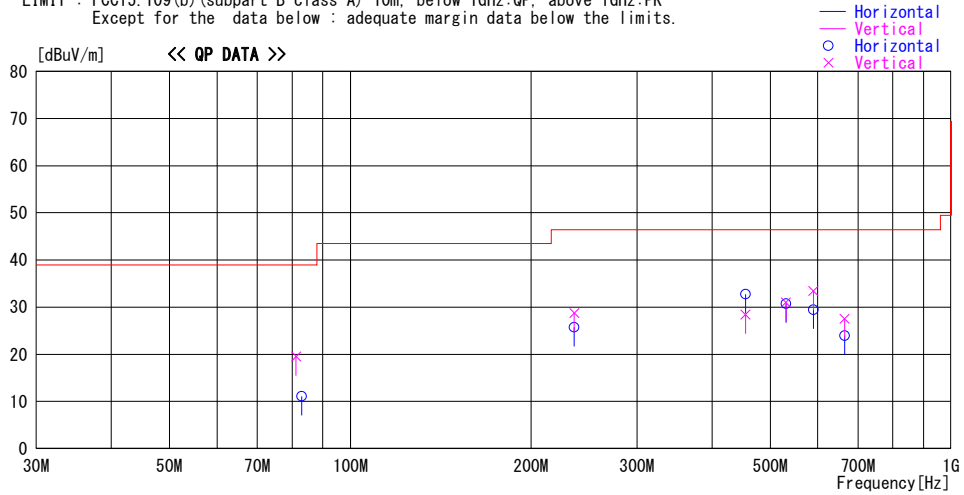

Frequency [MHz]	Reading [dBuV]	DET	Antenna		Level [dBuV/m]	Angle [Deg.]	Height [cm]	Polar.	Limit [dBuV/m]	Margin [dB]	Comment
			Factor [dB/m]	Loss& Gain [dB]							
81.224	43.3	QP	6.9	-30.7	19.5	86	100	Vert.	39.0	19.5	
82.963	34.6	QP	7.2	-30.7	11.1	168	400	Hori.	39.0	27.9	
235.931	46.2	QP	11.5	-29.0	28.7	221	100	Vert.	46.4	17.7	
235.931	43.2	QP	11.5	-29.0	25.7	215	351	Hori.	46.4	20.7	
454.778	43.0	QP	16.6	-26.9	32.7	206	278	Hori.	46.4	13.7	
454.778	38.7	QP	16.6	-26.9	28.4	309	100	Vert.	46.4	18.0	
530.865	38.9	QP	18.0	-26.2	30.7	13	186	Hori.	46.4	15.7	
530.865	39.2	QP	18.0	-26.2	31.0	211	252	Vert.	46.4	15.4	
589.788	36.3	QP	18.9	-25.8	29.4	351	156	Hori.	46.4	17.0	
589.788	40.3	QP	18.9	-25.8	33.4	126	263	Vert.	46.4	13.0	
665.112	33.4	QP	19.4	-25.3	27.5	0	100	Vert.	46.4	18.9	
665.692	29.8	QP	19.4	-25.3	23.9	0	128	Hori.	46.4	22.5	

CHART: WITH FACTOR

ANT TYPE: - 30 MHz: LOOP, 30 MHz - 200 MHz: BICONICAL, 200 MHz - 1000 MHz: LOGPERIODIC, 1000 MHz -: HORN  
CALCULATION: RESULT = READING + ANT FACTOR + LOSS & GAIN (CABLE + ATT - GAIN(AMP))

## Radiated emission

Report No. 12208121H  
Test place Ise EMC Lab.  
Semi Anechoic Chamber No.1  
Date May 10, 2018  
Temperature / Humidity 25 deg. C / 34 % RH  
Engineer Shuichi Ohyama  
(Above 1 GHz)  
Mode Mode 1 (WL40W1F-DAC4A-R)

LIMIT : FCC15.109(b)(subpart B class A) 10m, below 1GHz:QP, above 1GHz:PK  
FCC15.109(b)(subpart B class A) 10m, below 1GHz:QP, above 1GHz:AV

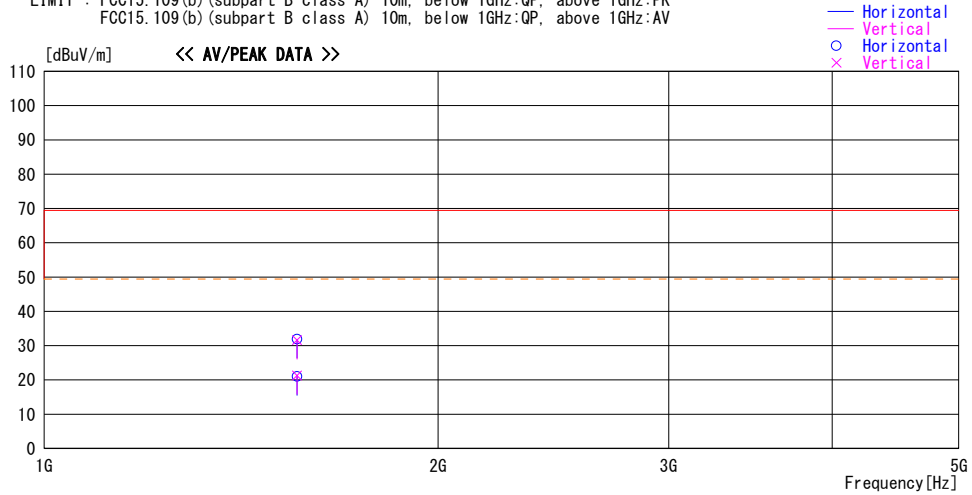

Frequency [MHz]	Reading [dBuV]	DET	Antenna	Loss&	Level [dBuV/m]	Angle [Deg]	Height [cm]	Polar.	Limit [dBuV/m]	Margin [dB]	Comment
			Factor [dB/m]	Gain [dB]							
1560.000	49.0	PK	26.0	-43.1	31.9	337	132	Hori.	69.5	37.6	
1560.000	38.1	AV	26.0	-43.1	21.0	337	132	Hori.	49.5	28.5	
1560.000	48.7	PK	26.0	-43.1	31.6	104	100	Vert.	69.5	37.9	
1560.000	38.4	AV	26.0	-43.1	21.3	104	100	Vert.	49.5	28.2	

CHART: WITH FACTOR

ANT TYPE: - 30 MHz: LOOP, 30 MHz - 200 MHz: BICONICAL, 200 MHz - 1000 MHz: LOGPERIODIC, 1000 MHz -: HORN  
CALCULATION: RESULT = READING + ANT FACTOR + LOSS & GAIN (CABLE - GAIN(AMP) + D-factor)

## Radiated emission

Report No. 12208121H  
Test place Ise EMC Lab.  
Semi Anechoic Chamber No.1  
Date May 10, 2018  
Temperature / Humidity 25 deg. C / 34 % RH  
Engineer Shuichi Ohyama  
(Below 1 GHz)  
Mode Mode 1 (WL40W1F-DAC4A-S)

LIMIT : FCC15.109(b)(subpart B class A) 10m, below 1GHz:QP, above 1GHz:PK  
Except for the data below : adequate margin data below the limits.

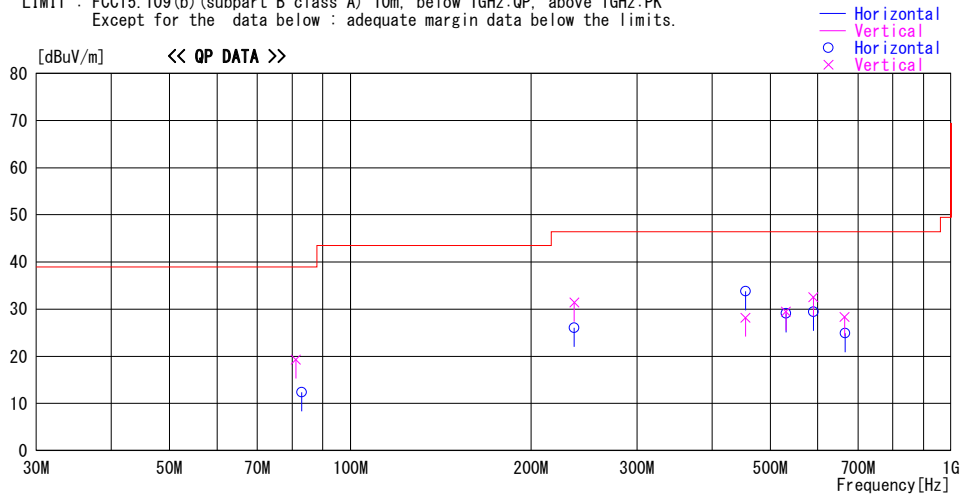

Frequency [MHz]	Reading [dBuV]	DET	Antenna		Level [dBuV/m]	Angle [Deg.]	Height [cm]	Polar.	Limit [dBuV/m]	Margin [dB]	Comment
			Factor [dB/m]	Loss & Gain [dB]							
81.189	43.1	QP	6.9	-30.7	19.3	92	100	Vert.	39.0	19.7	
82.968	35.9	QP	7.2	-30.7	12.4	359	400	Hori.	39.0	26.6	
235.925	48.9	QP	11.5	-29.0	31.4	219	100	Vert.	46.4	15.0	
235.925	43.5	QP	11.5	-29.0	26.0	207	382	Hori.	46.4	20.4	
454.779	44.1	QP	16.6	-26.9	33.8	268	276	Hori.	46.4	12.6	
454.779	38.5	QP	16.6	-26.9	28.2	310	100	Vert.	46.4	18.2	
530.853	37.3	QP	18.0	-26.2	29.1	347	173	Hori.	46.4	17.3	
530.853	37.7	QP	18.0	-26.2	29.5	259	249	Vert.	46.4	16.9	
589.809	36.3	QP	18.9	-25.8	29.4	317	173	Hori.	46.4	17.0	
589.809	39.4	QP	18.9	-25.8	32.5	138	258	Vert.	46.4	13.9	
664.914	34.2	QP	19.4	-25.3	28.3	0	100	Vert.	46.4	18.1	
666.010	30.8	QP	19.4	-25.3	24.9	0	139	Hori.	46.4	21.5	

CHART: WITH FACTOR

ANT TYPE: - 30 MHz: LOOP, 30 MHz - 200 MHz: BICONICAL, 200 MHz - 1000 MHz: LOGPERIODIC, 1000 MHz -: HORN  
CALCULATION: RESULT = READING + ANT FACTOR + LOSS & GAIN (CABLE + ATT - GAIN(AMP))



## Radiated emission

Report No. 12208121H  
Test place Ise EMC Lab.  
Semi Anechoic Chamber No.1  
Date May 10, 2018  
Temperature / Humidity 25 deg. C / 34 % RH  
Engineer Shuichi Ohyama  
(Above 1 GHz)  
Mode Mode 1 (WL40W1F-DAC4A-S)

LIMIT : FCC15.109(b)(subpart B class A) 10m, below 1GHz:QP, above 1GHz:PK  
FCC15.109(b)(subpart B class A) 10m, below 1GHz:QP, above 1GHz:AV

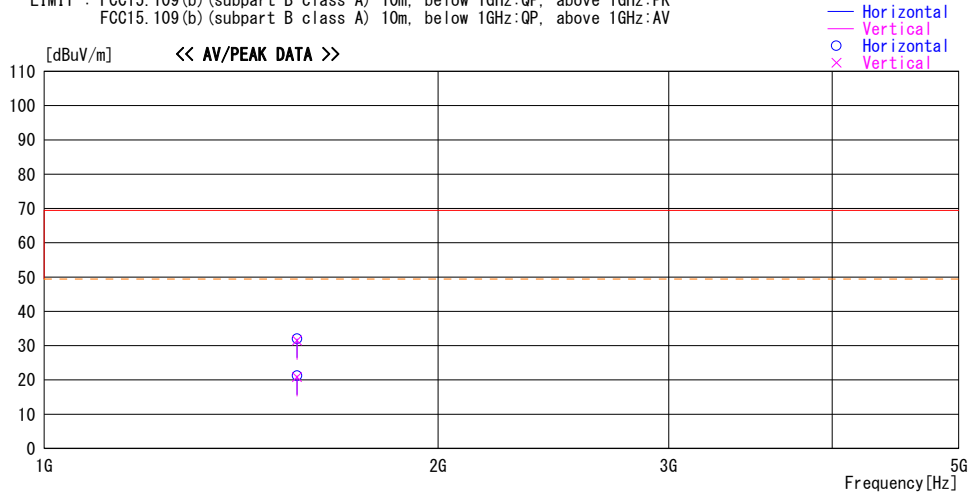

Frequency [MHz]	Reading [dBuV]	DET	Antenna	Loss&	Level	Angle	Height	Polar.	Limit	Margin	Comment
			Factor [dB/m]	Gain [dB]							
1560.000	49.1	PK	26.0	-43.1	32.0	337	130	Hori.	69.5	37.5	
1560.000	38.3	AV	26.0	-43.1	21.2	337	130	Hori.	49.5	28.3	
1560.000	48.6	PK	26.0	-43.1	31.5	112	100	Vert.	69.5	38.0	
1560.000	37.9	AV	26.0	-43.1	20.8	112	100	Vert.	49.5	28.7	

CHART: WITH FACTOR

ANT TYPE: - 30 MHz: LOOP, 30 MHz - 200 MHz: BICONICAL, 200 MHz - 1000 MHz: LOGPERIODIC, 1000 MHz -: HORN  
CALCULATION: RESULT = READING + ANT FACTOR + LOSS & GAIN (CABLE - GAIN(AMP) + D-factor)

## **APPENDIX 2: Test instruments**

### **Test Instruments**

Test item	LIMS ID	Description	Manufacturer	Model	Serial	Last Calibration Date	Calibration Due Date	Cal Int
CE	141290	Attenuator(13dB)	JFW Industries, Inc.	50FP-013H2 N	-	12/19/2017	12/31/2018	12
CE	141537	LISN(AMN)	Schwarzbeck	NSLK8127	8127-731	7/21/2017	7/31/2018	12
CE	141925	Terminator	TME	CT-01	-	11/9/2017	11/30/2018	12
CE	141215	Coaxial Cable	Fujikura/Suhner /TSJ	5D-2W/ 3D-2W/RG400u/ RFM-E421(SW)	-/01068 (Switcher)	6/26/2017	6/30/2018	12
RE	141213	Attenuator(6dB)	Weinschel Corp	2	BK7971	11/14/2017	11/30/2018	12
RE	141198	Biconical Antenna	Schwarzbeck	BBA9106	2513	11/23/2017	11/30/2018	12
RE	141350	Coaxial Cable	Suhner/storm/ Agilent/TSJ	-	-	9/26/2017	9/30/2018	12
RE	141264	Logperiodic Antenna(200-100 0MHz)	Schwarzbeck	VUSLP9111B	911B-189	1/30/2018	1/31/2019	12
RE	141585	Pre Amplifier	MITEQ	MLA-10K01-B01 -35	1237616	2/19/2018	2/27/2019	12
RE	141511	Horn Antenna 1-18GHz	Schwarzbeck	BBHA9120D	253	5/21/2017	5/30/2018	12
RE	141393	Microwave Cable	Junkosha	MWX221	1604S254(1 m) / 1608S088(5 m)	8/3/2017	8/31/2018	12
RE	141576	Pre Amplifier	AGILENT	8449B	3008A01671	2/16/2018	2/28/2019	12
RE.CE	142226	Measure	KOMELON	KMC-36	-	-	-	-
RE.CE	141530	Digital Tester	Fluke Corporation	FLUKE 26-3	78030621	8/7/2017	8/31/2018	12
RE.CE	141950	EMI Test Receiver	ROHDE & SCHWARZ	ESU26	100412	6/27/2017	6/30/2018	12
RE.CE	141152	EMI measurement program	TSJ	TEPTO-DV	-	-	-	-
RE.CE	141998	AC1 Semi Anechoic Chamber(NSA)	TDK	Semi Anechoic Chamber 10m	DA-06881	9/30/2017	9/30/2018	12
RE.CE	141566	Thermo-Hygrometer	CUSTOM	CTH-201	A08Q26	1/24/2018	1/31/2019	12

**\*Hyphens for Last Calibration Date, Calibration Due Date and Cal Int (month) are instruments that Calibration is not required (e.g. software), or instruments checked in advance before use.**

**The expiration date of the calibration is the end of the expired month.**

**All equipment is calibrated with valid calibrations. Each measurement data is traceable to the national or international standards.**

**As for some calibrations performed after the tested dates, those test equipment have been controlled by means of an unbroken chains of calibrations.**

**Test item:**

**CE: Conducted emission**

**RE: Radiated emission**

**UL Japan, Inc.**

**Ise EMC Lab.**

4383-326 Asama-cho, Ise-shi, Mie-ken 516-0021 JAPAN

Telephone : +81 596 24 8999

Facsimile : +81 596 24 8124