



EMI TEST REPORT

Test Report No. : 12129067H-B-R1

Applicant : M-SYSTEM CO., LTD
Type of Equipment : WIRELESS GATEWAY
Model No. : WL40MW1F
FCC ID : 2AOTF-0000002
Test regulation : FCC Part 15 Subpart B: 2018 Class A
Test Result : Complied

1. This test report shall not be reproduced in full or partial, without the written approval of UL Japan, Inc.
2. The results in this report apply only to the sample tested.
3. This sample tested is in compliance with the above regulation.
4. The test results in this report are traceable to the national or international standards.
5. This test report must not be used by the customer to claim product certification, approval, or endorsement by NVLAP, NIST, or any agency of the Federal Government.
6. This test report covers EMC technical requirements. It does not cover administrative issues such as Manual or non-EMC test related Requirements. (if applicable)
7. This report is a revised version of 12129067H-B. 12129067H-B is replaced with this report.

Date of test: March 16, 2018

Representative test engineer:

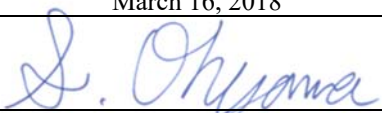

Shuichi Ohyama
Engineer

Consumer Technology Division

Approved by:



Satofumi Matsuyama
Engineer

Consumer Technology Division

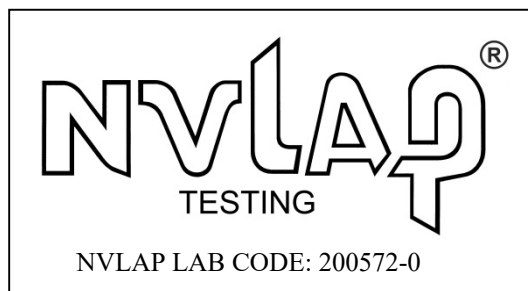

This laboratory is accredited by the NVLAP LAB CODE 200572-0, U.S.A. The tests reported herein have been performed in accordance with its terms of accreditation. *As for the range of Accreditation in NVLAP, you may refer to the WEB address, http://japan.ul.com/resources/emc_accredited/

UL Japan, Inc.

Ise EMC Lab.

4383-326 Asama-cho, Ise-shi, Mie-ken 516-0021 JAPAN

Telephone : +81 596 24 8999

Facsimile : +81 596 24 8124

13-EM-F0429

CONTENTS	PAGE
SECTION 1: Customer information.....	4
SECTION 2: Equipment under test (E.U.T.).....	4
SECTION 3: Test specification, procedures & results.....	5
SECTION 4: Operation of E.U.T. during testing.....	7
SECTION 5: Conducted Emission.....	9
SECTION 6: Radiated Emission.....	10
APPENDIX 1: Test data	11
Conducted Emission	11
Radiated emission	13
APPENDIX 2: Test instruments	17
APPENDIX 3: Photographs of test setup	18
Conducted Emission	18
Radiated Emission.....	20
Worst Case Position	24

SECTION 1: Customer information

Company Name : M-SYSTEM CO., LTD
Address : 5-2-55 MINAMITSUMORI, NISHINARI-KU, OSAKA, 557-0063
JAPAN
Telephone Number : +81-6-6659-8258
Facsimile Number : +81-6-6659-8514
Contact Person : Juri Sugiyama

SECTION 2: Equipment under test (E.U.T.)

2.1 Identification of E.U.T.

Type of Equipment : WIRELESS GATEWAY
Model No. : WL40MW1F
Serial No. : Refer to Section 4, Clause 4.2
Rating : DC 12 V (WL40MW1F-S)
DC 24 V (WL40MW1F-R)
Receipt Date of Sample : March 15, 2018
Country of Mass-production : Japan
Condition of EUT : Engineering prototype
(Not for Sale: This sample is equivalent to mass-produced items.)
Modification of EUT : No Modification by the test lab

2.2 Product Description

Model: WL40MW1F (referred to as the EUT in this report) is a WIRELESS GATEWAY.

Radio Specification

	IEEE802.15.4g
Frequency of operation	902 MHz - 928 MHz
Type of modulation	GFSK
Channel spacing	0.6 MHz
Antenna type	sleeve antenna (model: MH920-ANT-F(S)) rooftop antenna (model: MH920-ANT-F(R))
Antenna Connector type	Connector for connecting antenna
Antenna Gain	3 dBi (max) (sleeve antenna) 2 dBi (max) (rooftop antenna)
Clock frequency (maximum)	920 MHz

*WL40MW1F has following two types;

	Power input voltage
WL40MW1F-S	DC 12 V
WL40MW1F-R	DC 24V

* The RF module is a FCC certificated module made by Oki Electric Industry Co., Ltd. Model number: MH920-Mod-F (FCC ID: 2AKGW-1TD3016A1).

UL Japan, Inc.

Ise EMC Lab.

4383-326 Asama-cho, Ise-shi, Mie-ken 516-0021 JAPAN

Telephone : +81 596 24 8999

Facsimile : +81 596 24 8124

SECTION 3: Test specification, procedures & results

3.1 Test Specification

Test Specification : FCC Part 15 Subpart B
FCC Part 15 final revised on March 12, 2018 and effective April 11, 2018

Title : FCC 47CFR Part15 Radio Frequency Device
Subpart B Unintentional Radiators

* The revision on March 12, 2018, does not affect the test specification applied to the EUT.

3.2 Procedures and results

Item	Test Procedure	Limits	Deviation	Worst margin	Result
Conducted emission	FCC: ANSI C63.4: 2014 7. AC power - line conducted emission measurements	Class A	N/A	[QP] 19.5 dB 1.95594 MHz, L	Complied
	IC: ICES-003 Issue 6: 2016 + Amendment 1: 2017			[AV] 6.4 dB 1.95594 MHz, L	
Radiated emission	FCC: ANSI C63.4: 2014 8. Radiated emission measurements	Class A	N/A	4.0 dB 543.882 MHz, QP Vertical	Complied
	IC: ICES-003 Issue 6: 2016 + Amendment 1: 2017				
*Note: UL Japan, Inc's EMI Work Procedure 13-EM-W0420.					

3.3 Addition to standard

No addition, exclusion nor deviation has been made from the standard.

3.4 Uncertainty

EMI

The following uncertainties have been calculated to provide a confidence level of 95 % using a coverage factor $k = 2$.

Conducted emission

using Item	Frequency range	Uncertainty (+/-)
AMN (LISN)	0.009 MHz to 0.15 MHz	3.8 dB
	0.15 MHz to 30 MHz	3.4 dB

Radiated emission

Measurement distance	Frequency range	Uncertainty (+/-)	
10 m	30 MHz to 200 MHz	(Horizontal)	4.8 dB
		(Vertical)	4.9 dB
	200 MHz to 1000 MHz	(Horizontal)	5.0 dB
		(Vertical)	5.0 dB
3 m	1 GHz to 6 GHz	5.0 dB	
	6 GHz to 18 GHz	5.3 dB	
10 m	1 GHz to 18 GHz	5.2 dB	

Conducted Emission test

The data listed in this test report has enough margin, more than the site margin.

Radiated emission test (3 m and 10 m)

The data listed in this report meets the limits unless the uncertainty is taken into consideration.

UL Japan, Inc.

Ise EMC Lab.

4383-326 Asama-cho, Ise-shi, Mie-ken 516-0021 JAPAN
Telephone : +81 596 24 8999
Facsimile : +81 596 24 8124

3.5 Test Location

UL Japan, Inc. Ise EMC Lab.
 4383-326 Asama-cho, Ise-shi, Mie-ken 516-0021 JAPAN
 Telephone: +81 596 24 8999, Facsimile: +81 596 24 8124
 NVLAP Lab. code: 200572-0 / FCC Test Firm Registration Number: 199967

Test site	IC Registration Number	Width x Depth x Height (m)	Size of reference ground plane (m) / horizontal conducting plane	Other rooms	Maximum measurement distance
No.1 semi-anechoic chamber	2973C-1	19.2 x 11.2 x 7.7	7.0 x 6.0	No.1 Power source room	10 m
No.2 semi-anechoic chamber	2973C-2	7.5 x 5.8 x 5.2	4.0 x 4.0	-	3 m
No.3 semi-anechoic chamber	2973C-3	12.0 x 8.5 x 5.9	6.8 x 5.75	No.3 Preparation room	3 m
No.3 shielded room	-	4.0 x 6.0 x 2.7	N/A	-	-
No.4 semi-anechoic chamber	2973C-4	12.0 x 8.5 x 5.9	6.8 x 5.75	No.4 Preparation room	3 m
No.4 shielded room	-	4.0 x 6.0 x 2.7	N/A	-	-
No.5 semi-anechoic chamber	-	6.0 x 6.0 x 3.9	6.0 x 6.0	-	-
No.6 shielded room	-	4.0 x 4.5 x 2.7	4.0 x 4.5	-	-
No.6 measurement room	-	4.75 x 5.4 x 3.0	4.75 x 4.15	-	-
No.7 shielded room	-	4.7 x 7.5 x 2.7	4.7 x 7.5	-	-
No.8 measurement room	-	3.1 x 5.0 x 2.7	N/A	-	-
No.9 measurement room	-	8.8 x 4.6 x 2.8	2.4 x 2.4	-	-
No.11 measurement room	-	6.2 x 4.7 x 3.0	4.8 x 4.6	-	-

* Size of vertical conducting plane (for Conducted Emission test) : 2.0 m x 2.0 m for No.1, No.2, No.3, and No.4 semi-anechoic chambers and No.3 and No.4 shielded rooms.

3.6 Test data, Test instruments, and Test set up

Refer to APPENDIX.

SECTION 4: Operation of E.U.T. during testing

4.1 Operating Mode(s)

Mode	Remarks
Communication mode	-

4.2 Configuration and peripherals

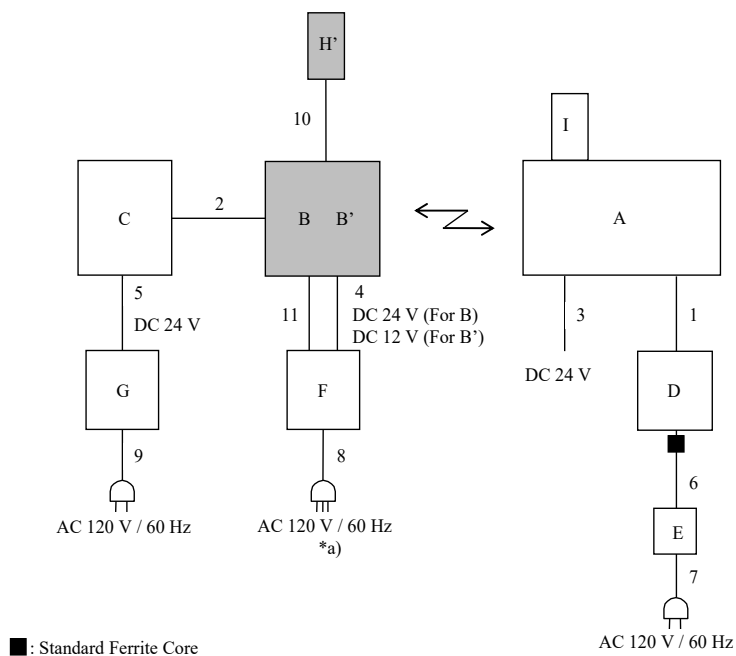
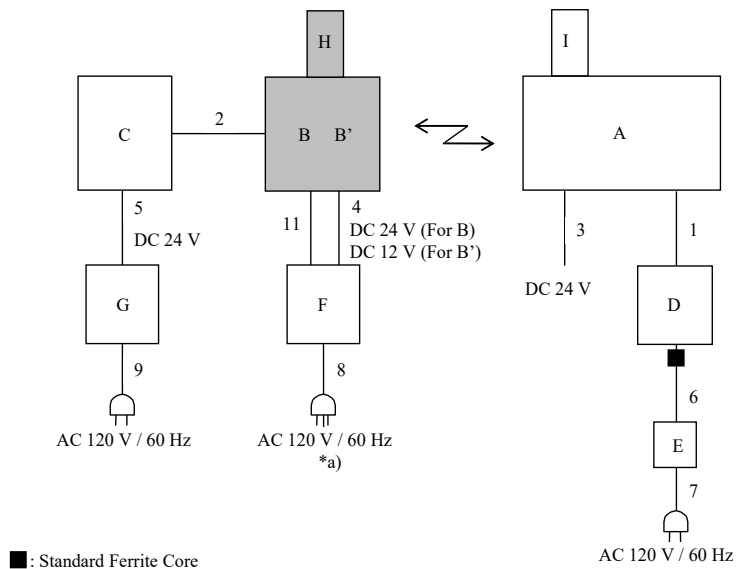

* Cabling and setup(s) were taken into consideration and test data was taken under worse case conditions.

*a) Conducted emission test was performed on this port

UL Japan, Inc.

Ise EMC Lab.

4383-326 Asama-cho, Ise-shi, Mie-ken 516-0021 JAPAN

Telephone : +81 596 24 8999

Facsimile : +81 596 24 8124

Description of EUT and Support equipment

No.	Item	Model number	Serial number	Manufacturer	Remarks
A	Wireless Gateway	WL40EW2F-R	P-34761	M-SYSTEM CO., LTD	-
B	Wireless Gateway	WL40MW1F-R	P-34769	M-SYSTEM CO., LTD	EUT
B'	Wireless Gateway	WL40MW1F-S	P-34766	M-SYSTEM CO., LTD	EUT
C	MODBUS I/O MODULE	R7M-DA16F-R	6K019029	M-SYSTEM CO., LTD	-
D	Laptop PC	2672-C2J	99-PPBKH	IBM	-
E	AC Adapter	08K8212	11S08K8212Z1Z7U B4160FD	IBM	-
F	DC Power Supply	PMC35-2A	13090501	KIKUSUI	*1)
G	DC Power Supply	MDC6-12024-M2	15211M	M-System	*1)
H	Sleeve antenna	MH920-ANT-F(S)	001	OKI	EUT *2)
H'	rooftop antenna	MH920-ANT-F(R)	001	OKI	EUT *2)
I	Sleeve antenna	MH920-ANT-F(S)	-	OKI	-

*1) Used for Conducted Emission test

*2) The test was performed with antenna which has been found to be worst in pre-check.

List of cables used

No.	Name	Length (m)	Shield		Remarks
			Cable	Connector	
1	LAN Cable	3.0	Shielded	Shielded	-
2	Signal Cable	2.0	Unshielded	Unshielded	-
3	DC Cable	1.5	Unshielded	Unshielded	-
4	DC Cable	1.5	Unshielded	Unshielded	-
5	DC Cable	1.5	Unshielded	Unshielded	-
6	DC Cable	1.8	Unshielded	Unshielded	-
7	AC Cable	0.9	Unshielded	Unshielded	-
8	AC Cable	1.5	Unshielded	Unshielded	*1)
9	AC Cable	2.0	Unshielded	Unshielded	*1)
10	Antenna Cable	2.5	Shielded	Shielded	-
11	Earth cable	1.5	Unshielded	Unshielded	*2)

*1) Used for Conducted Emission test

*2) The worst case was confirmed with and without Earth cable by pre check.

As a result, the test without Earth cable was the worst case.

Therefore the test without Earth cable was performed only.

SECTION 5: Conducted Emission

5.1 Operating environment

Test place : No.1 semi anechoic chamber
Temperature : See data
Humidity : See data

5.2 Test configuration

EUT was placed on a urethane platform of nominal size, 1.0 m by 1.5 m, raised 0.8 m above the conducting ground plane. The rear of tabletop was located 40 cm to the vertical conducting plane. The rear of EUT and its peripherals was aligned and flushed with rear of tabletop. All other surfaces of tabletop were at least 80 cm from any other grounded conducting surface. EUT was located 80 cm from the LISN/AMN and excess AC cable was bundled in center. I/O cables that were connected to the other peripherals were bundled in center. They were folded back and forth forming a bundle 30 cm to 40 cm long and were hanged at a 40 cm height to the ground plane. Each EUT current-carrying power lead, except the ground (safety) lead, was individually connected through a LISN/AMN to the input power source. All unused 50 ohm connectors of the LISN/AMN were resistivity terminated in 50 ohm when not connected to the measuring equipment. Photographs of the set up are shown in Appendix 3.

Frequency range : 0.15 MHz - 30 MHz
EUT position : Table top
EUT operation mode : See Clause 4.1

5.3 Test procedure

The AC Mains Terminal Continuous disturbance Voltage has been measured with the EUT within a semi anechoic chamber. The EUT was connected to a Line Impedance Stabilization Network (LISN)/ Artificial Mains network (AMN). An overview sweep with peak detection has been performed. The measurements have been performed with a quasi-peak detector and if required, with an average detector.

The conducted emission measurements were made with the following detector function of the test receiver.

Detector Type : Quasi-Peak and CISPR AV
IF Bandwidth : 9 kHz

5.4 Test result

Summary of the test results: Pass

The test result is rounded off to one or two decimal places, so some differences might be observed.

Date: March 16, 2018

Test engineer: Shuichi Ohyama

SECTION 6: Radiated Emission

6.1 Operating environment

Test place : No.1 semi anechoic chamber
Temperature : See data
Humidity : See data

6.2 Test configuration

EUT was placed on a urethane platform of nominal size, 1.0 m by 1.5 m, raised 0.8 m above the conducting ground plane. The EUT was set on the edge of the tabletop. Test was made with the antenna positioned in both the horizontal and vertical planes of polarization. The measurement antenna was varied in height above the conducting ground plane to obtain the maximum signal strength. Photographs of the set up are shown in Appendix 3.

6.3 Test conditions

Frequency range : 30 MHz - 200 MHz (Biconical antenna) / 200 MHz - 1000 MHz (Logperiodic antenna)
1000 MHz - 10000 MHz (Horn antenna)
Test distance : 10 m (30 MHz - 1000 MHz) / 3 m (1000 MHz - 10000 MHz)
EUT position : Table top
EUT operation mode : See Clause 4.1

6.4 Test procedure

The height of the measuring antenna varied between 1 and 4 m and EUT was rotated a full revolution in order to obtain the maximum value of the electric field intensity. The measurements were performed for both vertical and horizontal antenna polarization with the Test Receiver. The radiated emission measurements were made with the following detector function of the Test Receiver.

Frequency	Below 1GHz	Above 1GHz *1)
Instrument used	Test Receiver	Test Receiver
IF Bandwidth	QP: BW 120 kHz	PK: BW 1 MHz, CISPR AV: BW 1 MHz

*1) The measurement data was adjusted to a 10 m distance using the following Distance Factor.
Distance Factor: $20 \times \log(3.8 \text{ m} / 10 \text{ m}) = -8.4 \text{ dB}$

The test was made on EUT at the normal use position.

6.5 Test result

Summary of the test results: Pass

The limit is rounded down to one decimal place.
The test result is rounded off to one or two decimal places, so some differences might be observed.

Date: March 16, 2018

Test engineer: Shuichi Ohyama

APPENDIX 1: Test data

Conducted Emission

Report No. 12129067H
Test place Ise EMC Lab.
Semi Anechoic Chamber No.1
Date March 16, 2018
Temperature / Humidity 25 deg. C / 32 % RH
Engineer Shuichi Ohyama
Mode Mode 1 (WL40MW1F-R)

LIMIT : FCC15.107(b) QP ClassA
FCC15.107(b) AV ClassA

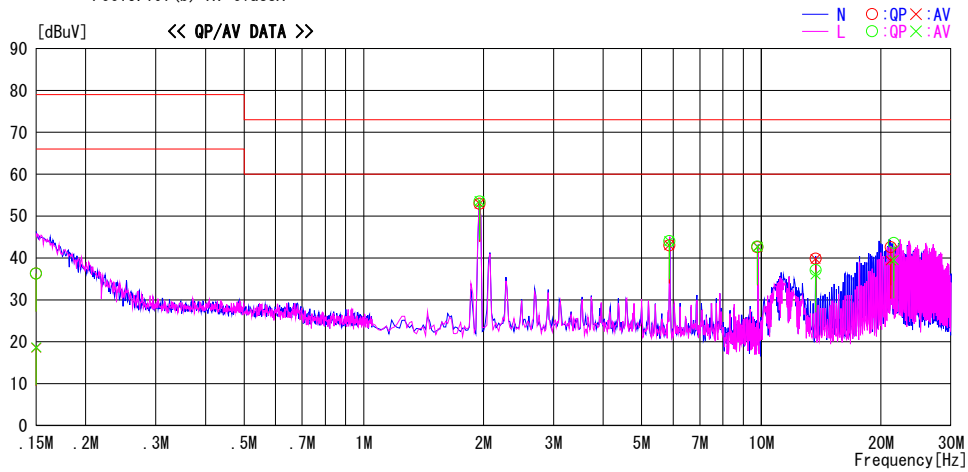

Frequency [MHz]	Reading Level		Corr. Factor [dB]	Results		Limit		Margin		Phase	Comment
	QP [dBuV]	AV [dBuV]		QP [dBuV]	AV [dBuV]	QP [dBuV]	AV [dBuV]	QP [dB]	AV [dB]		
0.15000	23.1	5.4	13.2	36.3	18.6	79.0	66.0	42.7	47.4	N	
1.95516	39.3	39.4	13.6	52.9	53.0	73.0	60.0	20.1	7.0	N	
5.86712	29.0	29.1	14.0	43.0	43.1	73.0	60.0	30.0	16.9	N	
9.77664	28.3	28.4	14.3	42.6	42.7	73.0	60.0	30.4	17.3	N	
13.68817	25.2	25.2	14.6	39.8	39.8	73.0	60.0	33.2	20.2	N	
21.15758	27.6	24.4	15.0	42.6	39.4	73.0	60.0	30.4	20.6	N	
0.15000	23.1	5.5	13.2	36.3	18.7	79.0	66.0	42.7	47.3	L	
1.95594	39.9	40.0	13.6	53.5	53.6	73.0	60.0	19.5	6.4	L	
5.86844	30.0	30.1	14.0	44.0	44.1	73.0	60.0	29.0	15.9	L	
9.78008	28.4	28.4	14.3	42.7	42.7	73.0	60.0	30.3	17.3	L	
13.69476	22.5	21.5	14.6	37.1	36.1	73.0	60.0	35.9	23.9	L	
21.52363	28.6	24.5	15.0	43.6	39.5	73.0	60.0	29.4	20.5	L	

CHART: WITH FACTOR Peak hold data. CALCULATION : RESULT = READING + C.F (LISN + CABLE + ATT)
Except for the above table: adequate margin data below the limits.

Conducted Emission

Report No. 12129067H
Test place Ise EMC Lab.
Semi Anechoic Chamber No.1
Date March 16, 2018
Temperature / Humidity 25 deg. C / 32 % RH
Engineer Shuichi Ohyama
Mode Mode 1 (WL40MW1F-S)

LIMIT : FCC15.107(b) QP ClassA
FCC15.107(b) AV ClassA

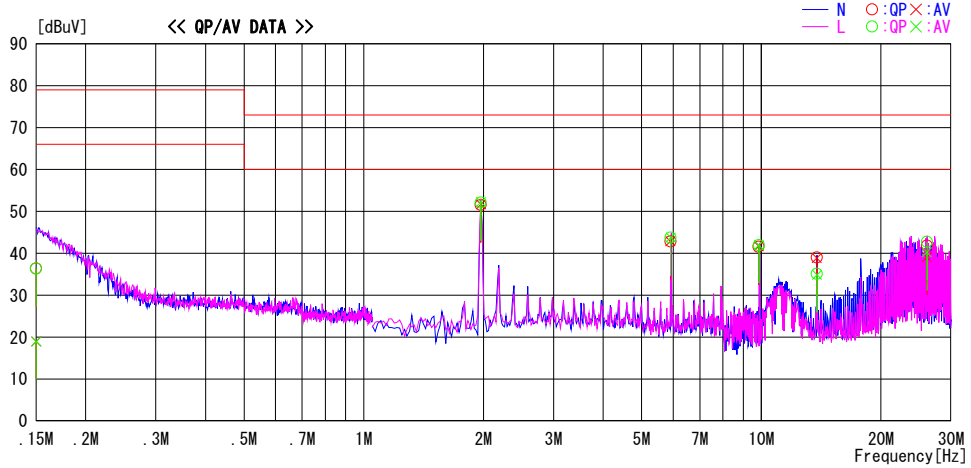

Frequency [MHz]	Reading Level		Corr. [dB]	Results		Limit		Margin		Phase	Comment
	QP [dBuV]	AV [dBuV]		Factor [dB]	QP [dBuV]	AV [dBuV]	QP [dBuV]	AV [dBuV]	QP [dB]		
0.15000	23.2	5.8	13.2	36.4	19.0	79.0	66.0	42.6	47.0	N	
1.96964	38.0	38.1	13.6	51.6	51.7	73.0	60.0	21.4	8.3	N	
5.90968	28.8	28.9	14.0	42.8	42.9	73.0	60.0	30.2	17.1	N	
9.85068	27.3	27.4	14.3	41.6	41.7	73.0	60.0	31.4	18.3	N	
13.78956	24.4	24.3	14.6	39.0	38.9	73.0	60.0	34.0	21.1	N	
26.09082	26.5	23.8	15.3	41.8	39.1	73.0	60.0	31.2	20.9	N	
0.15000	23.2	5.8	13.2	36.4	19.0	79.0	66.0	42.6	47.0	L	
1.96992	38.5	38.6	13.6	52.1	52.2	73.0	60.0	20.9	7.8	L	
5.91114	29.7	29.8	14.0	43.7	43.8	73.0	60.0	29.3	16.2	L	
9.85206	27.6	27.7	14.3	41.9	42.0	73.0	60.0	31.1	18.0	L	
13.79386	20.5	20.3	14.6	35.1	34.9	73.0	60.0	37.9	25.1	L	
26.08124	27.4	24.9	15.3	42.7	40.2	73.0	60.0	30.3	19.8	L	

CHART: WITH FACTOR Peak hold data. CALCULATION : RESULT = READING + C.F (LISN + CABLE + ATT)
Except for the above table: adequate margin data below the limits.

Radiated emission

Report No. 12129067H
Test place Ise EMC Lab.
Semi Anechoic Chamber No.1
Date March 16, 2018
Temperature / Humidity 25 deg. C / 32 % RH
Engineer Shuichi Ohyama
(Below 1 GHz)
Mode Mode 1 (WL40MW1F-R)

LIMIT : FCC15.109(b) (subpart B class A) 10m, below 1GHz:QP, above 1GHz:PK
FCC15.109(b) (subpart B class A) 10m, below 1GHz:QP, above 1GHz:AV

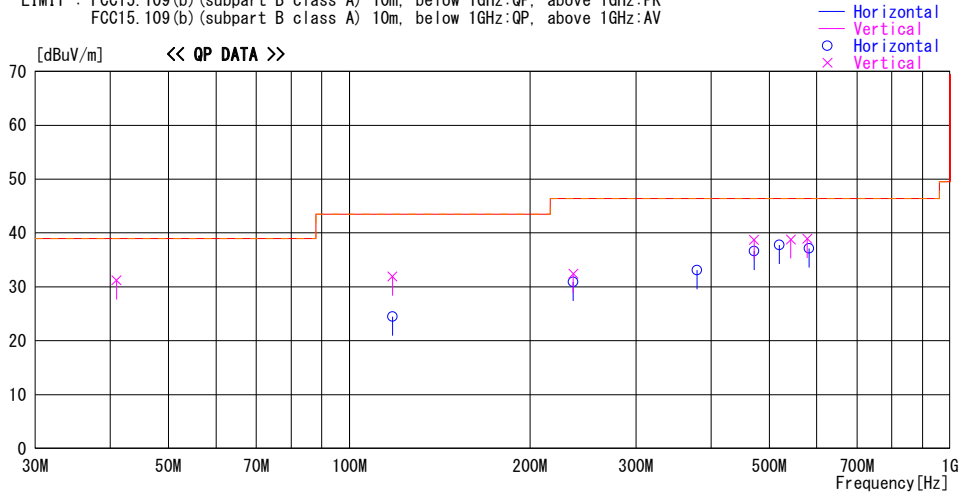

Frequency [MHz]	Reading [dBuV]	DET	Antenna		Level [dBuV/m]	Angle [Deg.]	Height [cm]	Polar.	Limit [dBuV/m]	Margin [dB]	Comment
			Factor [dB/m]	Loss& Gain [dB]							
40.984	48.8	QP	13.8	-31.4	31.2	8	100	Vert.	39.0	7.8	
117.982	49.9	QP	12.3	-30.3	31.9	98	100	Vert.	43.5	11.6	
117.982	42.5	QP	12.3	-30.3	24.5	172	400	Hori.	43.5	19.0	
235.922	49.9	QP	11.5	-29.0	32.4	171	100	Vert.	46.4	14.0	
235.922	48.4	QP	11.5	-29.0	30.9	355	400	Hori.	46.4	15.5	
379.114	45.5	QP	15.1	-27.5	33.1	178	262	Hori.	46.4	13.3	
471.845	48.4	QP	17.0	-26.7	38.7	234	319	Vert.	46.4	7.7	
471.845	46.3	QP	17.0	-26.7	36.6	321	189	Hori.	46.4	9.8	
543.124	46.8	QP	18.2	-26.2	38.8	359	100	Vert.	46.4	7.6	
519.778	46.3	QP	17.8	-26.3	37.8	157	138	Hori.	46.4	8.6	
578.311	46.0	QP	18.7	-25.8	38.9	359	100	Vert.	46.4	7.5	
582.269	44.1	QP	18.8	-25.8	37.1	157	121	Hori.	46.4	9.3	

CHART: WITH FACTOR

ANT TYPE: - 30 MHz: LOOP, 30 MHz - 200 MHz: BICONICAL, 200 MHz - 1000 MHz: LOGPERIODIC, 1000 MHz -: HORN
CALCULATION: RESULT = READING + ANT FACTOR + LOSS & GAIN (CABLE + ATT - GAIN(AMP))

Radiated emission

Report No. 12129067H
Test place Ise EMC Lab.
Semi Anechoic Chamber No.1
Date March 16, 2018
Temperature / Humidity 25 deg. C / 32 % RH
Engineer Shuichi Ohyama
(Above 1 GHz)
Mode Mode 1 (WL40MW1F-R)

LIMIT : FCC15.109(b) (subpart B class A) 10m, below 1GHz:QP, above 1GHz:PK
FCC15.109(b) (subpart B class A) 10m, below 1GHz:QP, above 1GHz:AV

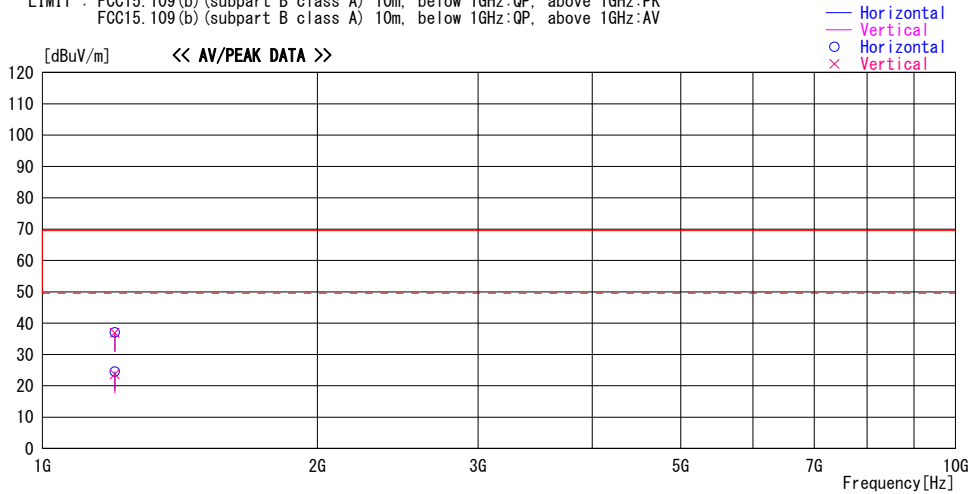

Frequency [MHz]	Reading [dBuV]	DET	Antenna	Loss&	Level	Angle	Height	Polar.	Limit	Margin	Comment
			Factor [dB/m]	Gain [dB]							
1200.000	55.3	PK	25.4	-43.7	37.0	170	100	Hor i.	69.5	32.5	
1200.000	42.8	AV	25.4	-43.7	24.5	170	100	Hor i.	49.5	25.0	
1200.000	55.2	PK	25.4	-43.7	36.9	233	100	Vert.	69.5	32.6	
1200.000	42.0	AV	25.4	-43.7	23.7	233	100	Vert.	49.5	25.8	

CHART: WITH FACTOR

ANT TYPE: - 30 MHz: LOOP, 30 MHz - 200 MHz: BICONICAL, 200 MHz - 1000 MHz: LOGPERIODIC, 1000 MHz -: HORN
CALCULATION: RESULT = READING + ANT FACTOR + LOSS & GAIN (CABLE - GAIN(AMP) + D-factor)

Radiated emission

Report No. 12129067H
Test place Ise EMC Lab.
Semi Anechoic Chamber No.1
Date March 16, 2018
Temperature / Humidity 25 deg. C / 32 % RH
Engineer Shuichi Ohyama
(Below 1 GHz)
Mode Mode 1 (WL40MW1F-S)

LIMIT : FCC15.109(b) (subpart B class A) 10m, below 1GHz:QP, above 1GHz:PK
FCC15.109(b) (subpart B class A) 10m, below 1GHz:QP, above 1GHz:AV

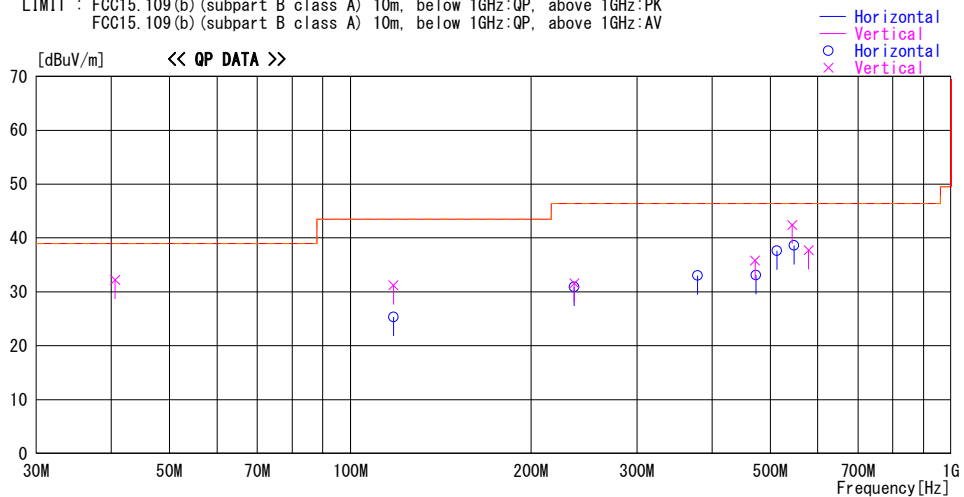

Frequency [MHz]	Reading [dBuV]	DET	Antenna		Level [dBuV/m]	Angle [Deg.]	Height [cm]	Polar.	Limit [dBuV/m]	Margin [dB]	Comment
			Factor [dB/m]	Loss& Gain [dB]							
40.596	49.7	QP	13.9	-31.4	32.2	0	100	Vert.	39.0	6.8	
117.973	49.2	QP	12.3	-30.3	31.2	103	100	Vert.	43.5	12.3	
117.973	43.3	QP	12.3	-30.3	25.3	178	400	Hori.	43.5	18.2	
235.922	49.1	QP	11.5	-29.0	31.6	169	100	Vert.	46.4	14.8	
235.922	48.4	QP	11.5	-29.0	30.9	355	400	Hori.	46.4	15.5	
378.681	45.4	QP	15.1	-27.5	33.0	167	287	Hori.	46.4	13.4	
471.848	45.5	QP	17.0	-26.7	35.8	210	367	Vert.	46.4	10.6	
473.278	42.8	QP	17.0	-26.7	33.1	201	215	Hori.	46.4	13.3	
543.882	50.3	QP	18.2	-26.1	42.4	359	100	Vert.	46.4	4.0	
512.622	46.3	QP	17.7	-26.4	37.6	161	136	Hori.	46.4	8.8	
579.348	44.8	QP	18.7	-25.8	37.7	359	100	Vert.	46.4	8.7	
548.072	46.4	QP	18.3	-26.1	38.6	155	140	Hori.	46.4	7.8	

CHART: WITH FACTOR

ANT TYPE: - 30 MHz: LOOP, 30 MHz - 200 MHz: BICONICAL, 200 MHz - 1000 MHz: LOGPERIODIC, 1000 MHz -: HORN
CALCULATION: RESULT = READING + ANT FACTOR + LOSS & GAIN (CABLE + ATT - GAIN(AMP))

Radiated emission

Report No. 12129067H
Test place Ise EMC Lab.
Semi Anechoic Chamber No.1
Date March 16, 2018
Temperature / Humidity 25 deg. C / 32 % RH
Engineer Shuichi Ohyama
(Above 1 GHz)
Mode Mode 1 (WL40MW1F-S)

LIMIT : FCC15.109(b) (subpart B class A) 10m, below 1GHz:QP, above 1GHz:PK
FCC15.109(b) (subpart B class A) 10m, below 1GHz:QP, above 1GHz:AV

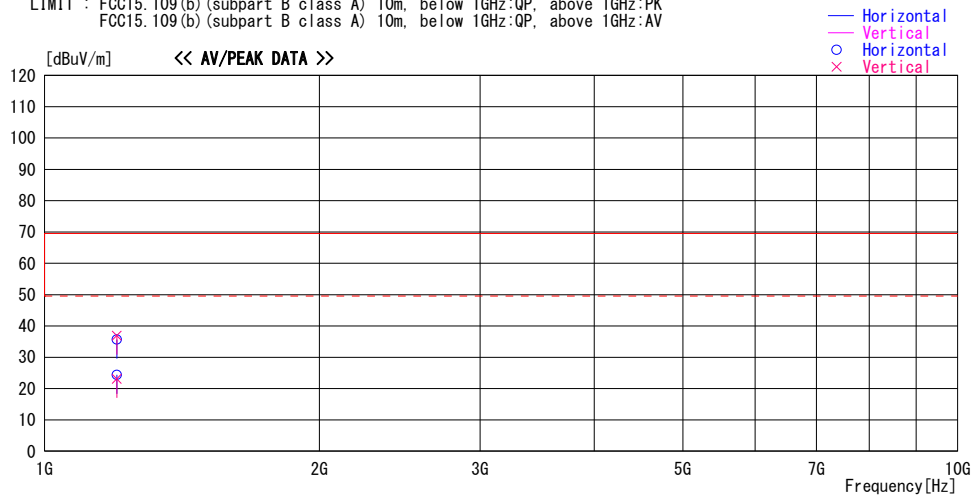

Frequency [MHz]	Reading [dBuV]	DET	Antenna	Loss&	Level	Angle	Height	Polar.	Limit	Margin	Comment
			Factor [dB/m]	Gain [dB]							
1200.000	53.9	PK	25.4	-43.7	35.6	169	100	Hor i.	69.5	33.9	
1200.000	42.7	AV	25.4	-43.7	24.4	169	100	Hor i.	49.5	25.1	
1200.000	55.2	PK	25.4	-43.7	36.9	233	100	Vert.	69.5	32.6	
1200.000	41.4	AV	25.4	-43.7	23.1	233	100	Vert.	49.5	26.4	

CHART: WITH FACTOR

ANT TYPE: - 30 MHz: LOOP, 30 MHz - 200 MHz: BICONICAL, 200 MHz - 1000 MHz: LOGPERIODIC, 1000 MHz -: HORN
CALCULATION: RESULT = READING + ANT FACTOR + LOSS & GAIN (CABLE - GAIN(AMP) + D-factor)

APPENDIX 2: Test instruments

EMI Test Instruments

Control No.	Instrument	Manufacturer	Model No	Serial No	Test Item	Calibration Date * Interval(month)
MAEC-01	Semi Anechoic Chamber(NSA)	TDK	Semi Anechoic Chamber 10m	DA-06881	CE,RE	2017/09/30 * 12
MOS-27	Thermo-Hygrometer	CUSTOM	CTH-201	A08Q26	CE,RE	2018/01/24 * 12
MJM-25	Measure	KOMELON	KMC-36	-	CE,RE	-
COTS-MEMI	EMI measurement program	TSJ	TEPTO-DV	-	CE,RE	-
MTR-09	EMI Test Receiver	Rohde & Schwarz	ESU26	100412	CE,RE	2017/06/27 * 12
MLS-25	LISN(AMN)	Schwarzbeck	NSLK8127	8127-731	CE(AE)	2017/07/21 * 12
MLS-26	LISN(AMN)	Schwarzbeck	NSLK8127	8127-732	CE(EUT)	2017/07/21 * 12
MTA-28	Terminator	TME	CT-01	-	CE	2017/11/09 * 12
MCC-03	Coaxial Cable	Fujikura/Suhner/TSJ	5D-2W(20m)/ 3D-2W(7.5m)/ RG400u(1.5m)/ RFM-E421 (Switcher)	-/01068(Switcher)	CE	2017/06/26 * 12
MAT-64	Attenuator(13dB)	JFW Industries, Inc.	50FP-013H2 N	-	CE	2017/12/19 * 12
MMM-03	Digital Tester	Fluke	FLUKE 26-3	78030621	CE,RE	2017/08/07 * 12
KBA-05	Biconical Antenna	Schwarzbeck	BBA9106	2513	RE	2017/11/23 * 12
MLA-20	Logperiodic Antenna(200-1000MHz)	Schwarzbeck	VUSLP9111B	911B-189	RE	2018/01/30 * 12
MAT-08	Attenuator(6dB)	Weinschel Corp	2	BK7971	RE	2017/11/14 * 12
MCC-02	Coaxial Cable	Suhner/storm/Agilent/ TSJ	-	-	RE	2017/09/26 * 12
MPA-19	Pre Amplifier	MITEQ	MLA-10K01-B01-35	1237616	RE	2018/02/20 * 12
MHA-05	Horn Antenna 1-18GHz	Schwarzbeck	BBHA9120D	253	RE	2017/05/22 * 12
MPA-01	Pre Amplifier	Agilent	8449B	3008A01671	RE	2018/02/16 * 12
MCC-217	Microwave Cable	Junkosha	MWX221	1604S254(1 m) / 1608S088(5 m)	RE	2017/08/02 * 12

The expiration date of the calibration is the end of the expired month.

All equipment is calibrated with valid calibrations. Each measurement data is traceable to the national or international standards.

As for some calibrations performed after the tested dates, those test equipment have been controlled by means of an unbroken chains of calibrations.

Test item:

CE: Conducted emission

RE: Radiated emission

UL Japan, Inc.

Ise EMC Lab.

4383-326 Asama-cho, Ise-shi, Mie-ken 516-0021 JAPAN

Telephone : +81 596 24 8999

Facsimile : +81 596 24 8124