



FCC PART 15 B
TEST REPORT

For

Xiamen Ursalink Technology Co., Ltd.

3/F,NO.46 Guanri Road,2nd Software Park,Xiamen,China

FCC ID: 2AOSV-UR71

Report Type: Original Report	Product Type: Industrial Cellular Router
Report Number:	RXM171108050-00A
Report Date:	2018-01-19
Reviewed By:	Jerry Zhang EMC Manager <i>Jerry Zhang</i>
Test Laboratory:	Bay Area Compliance Laboratories Corp. (Dongguan) No.69 Pulongcun, Puxinhu Industry Area, Tangxia, Dongguan, Guangdong, China Tel: +86-769-86858888 Fax: +86-769-86858891 www.baclcorp.com.cn

Note: This test report is prepared for the customer shown above and for the device described herein. It may not be duplicated or used in part without prior written consent from Bay Area Compliance Laboratories Corp. (Dongguan).

TABLE OF CONTENTS

GENERAL INFORMATION	3
PRODUCT DESCRIPTION FOR EQUIPMENT UNDER TEST (EUT)	3
OBJECTIVE	3
RELATED SUBMITTAL(S)/GRANT(S).....	3
TEST METHODOLOGY	3
MEASUREMENT UNCERTAINTY.....	4
TEST FACILITY	4
SYSTEM TEST CONFIGURATION	5
DESCRIPTION OF TEST CONFIGURATION	5
EUT EXERCISE SOFTWARE	5
EQUIPMENT MODIFICATIONS	5
LOCAL SUPPORT EQUIPMENT LIST AND DETAILS	5
SUPPORT CABLE LIST AND DETAILS	5
CONFIGURATION OF TEST SETUP	6
SUMMARY OF TEST RESULTS	7
FCC§15.107 - CONDUCTED EMISSIONS	8
EUT SETUP.....	8
EMI TEST RECEIVER SETUP.....	8
TEST EQUIPMENT LIST AND DETAILS.....	9
TEST PROCEDURE	9
CORRECTED AMPLITUDE & MARGIN CALCULATION	9
TEST RESULTS SUMMARY.....	10
TEST DATA	10
FCC §15.109 - RADIATED SPURIOUS EMISSIONS	13
EUT SETUP.....	13
EMI TEST RECEIVER SETUP.....	14
TEST PROCEDURE	14
TEST EQUIPMENT LIST AND DETAILS.....	14
CORRECTED AMPLITUDE & MARGIN CALCULATION	15
TEST DATA	15

GENERAL INFORMATION

Product Description for Equipment Under Test (EUT)

The *Xiamen Ursalink Technology Co., Ltd.*'s product, model number: **UR71 (FCC ID: 2AOSV-UR71)** (the "EUT") in this report was a **Industrial Cellular Router**, which was measured approximately: 100 mm (L) x 96.1 mm (W) x 30 mm (H), rated input voltage: DC12V from adapter. The highest operation frequency is 2690 MHz.

Adapter Information:

MODEL: OH-1015A1201000U1-UL

INPUT: AC 100~240V, 50/60Hz, 350mA

OUTPUT: DC 12V, 1A

**All measurement and test data in this report was gathered from production sample serial number:171108050 (Assigned by BAACL,Dongguan). The EUT was received on 2017-11-08.*

Objective

This test report is prepared on behalf of *Xiamen Ursalink Technology Co., Ltd.* In accordance with Part 2, Subpart J, and Part 15-Subparts A and B of the Federal Communications Commission's rules.

The objective of the manufacturer is to determine the compliance of EUT with FCC Part 15 B Class B.

Related Submittal(s)/Grant(s)

N/A

Test Methodology

All measurements contained in this report were conducted with ANSI C63.4-2014, American National Standard for Methods of Measurement of Radio-Noise Emissions from Low-Voltage Electrical and Electronic Equipment in the range of 9 kHz to 40 GHz.

All radiated and conducted emissions measurement was performed at Bay Area Compliance Laboratories Corp. (Dongguan).

Measurement Uncertainty

Parameter	Measurement Uncertainty
Unwanted Emissions, radiated	30M~200MHz: 4.58 dB for Horizontal, 4.59 dB for Vertical 200M~1GHz: 4.83 dB for Horizontal, 5.85 dB for Vertical 1G~6GHz: 4.45 dB, 6G~26.5GHz: 5.23 dB
Temperature	±1 °C
Humidity	±5%
AC Power Lines Conducted Emission	3.12 dB (150 kHz to 30 MHz)

Test Facility

The Test site used by Bay Area Compliance Laboratories Corp. (Dongguan) to collect test data is located on the No.69 Pulongcun, Puxinhu Industry Area, Tangxia, Dongguan, Guangdong, China.

The test site has been approved by the FCC under the KDB 974614 D01 and is listed in the FCC Public Access Link (PAL) database, FCC Registration No. : 897218, the FCC Designation No. : CN1220.

The test site has been registered with ISED Canada under ISED Canada Registration Number 3062D.

SYSTEM TEST CONFIGURATION

Description of Test Configuration

The system was configured for testing in Data communication mode.
Data communication with RJ45 port and COM port between EUT and Laptop.

EUT Exercise Software

The software “Tfgen traffic generator Version 1.00.” was used during test.

Equipment Modifications

No modification was made to the EUT tested.

Local Support Equipment List and Details

Manufacturer	Description	Model	Serial Number
DELL	Laptop	PP11L	1CVM0C1
Macally	USB HDD	B-S250SU	7491000064
DELL	Keyboard	SK-8115	CN-0J4628-71616-52H-ORT6
HP	Printer	C3990A	JPZW030603
Sandisk	micro SD card	N/A	N/A

Support Cable List and Details

Cable Description	Shielding Type	Ferrite Core	Length (m)	From Port	To
Serial Cable	No	No	1.5*2	Serial Port of Laptop	EUT
USB Cable	No	No	2	USB Port of Laptop	Keyboard
USB Cable	No	No	0.7	USB Port of Laptop	USB HDD
Parallel Cable	No	No	1.4	Parallel Port of Laptop	Printer
Power Cable	No	yes	1.5	Power Port of EUT	Adapter
Antenna Cable	No	No	2.5*2	Antenna Port of EUT	Antenna

Configuration of Test Setup

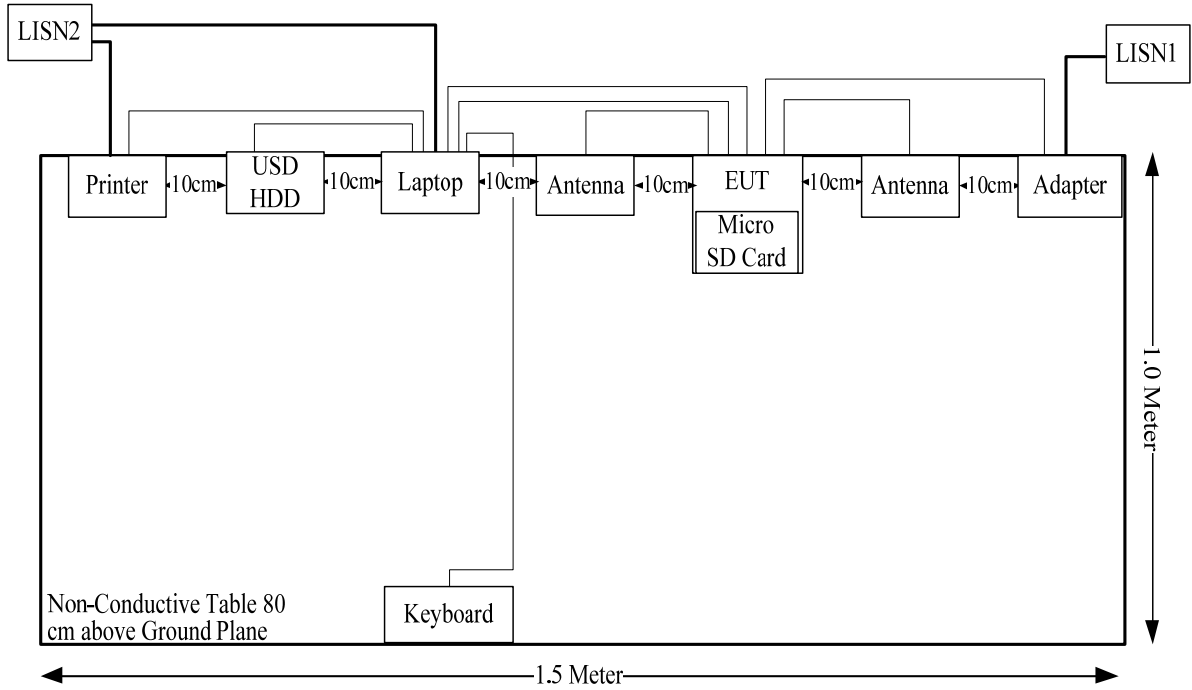

SUMMARY OF TEST RESULTS

FCC Rules	Description of Test	Results
§15.107	Conducted Emissions	Compliant
§15.109	Radiated Emissions	Compliant

FCC§15.107 - CONDUCTED EMISSIONS

EUT Setup

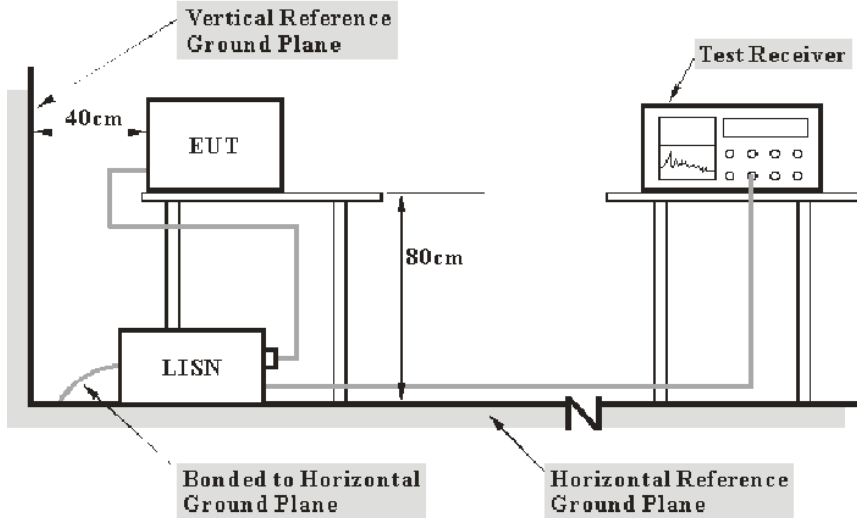

- Note: 1. Support units were connected to second LISN.
 2. Both of LISNs (AMN) 80 cm from EUT and at the least 80 cm from other units and other metal planes support units.

The setup of EUT is according with per ANSI C63.4-2014 measurement procedure. The specification used was with the FCC Part 15 B Class B limits.

The external I/O cables were draped along the test table and formed a bundle 30 to 40 cm long in the middle.

The adapter was connected to the Main LISN with 120V/60Hz AC power source.

EMI Test Receiver Setup

The EMI test receiver was set to investigate the spectrum from 150 kHz to 30 MHz.

During the conducted emission test, the EMI test receiver was set with the following configurations:

Frequency Range	IF B/W
150 kHz – 30 MHz	9 kHz

Test Equipment List and Details

Manufacturer	Description	Model	Serial Number	Calibration Date	Calibration Due Date
R&S	L.I.S.N	ESH2-Z5	892107/021	2017-09-25	2018-09-25
R&S	Two-line V-network	ENV 216	3560.6550.12	2017-12-08	2018-12-08
R&S	Test Software	EMC32	Version8.53.0	N/A	N/A
N/A	Coaxial Cable	C-NJNJ-50	C-0200-01	2017-09-05	2018-09-05
R&S	EMI Test Receiver	ESCS 30	830245/006	2017-12-08	2018-12-08

* **Statement of Traceability:** Bay Area Compliance Laboratories Corp. (Dongguan) attests that all calibrations have been performed traceable to National Primary Standards and International System of Units (SI).

Test Procedure

During the conducted emission test, the adapter of laptop was connected to the outlet of the first LISN and the other support equipments were connected to the outlet of the second LISN.

Maximizing procedure was performed on the six (6) highest emissions of the EUT.

All data was recorded in the Quasi-peak and average detection mode.

Corrected Amplitude & Margin Calculation

The basic equation is as follows:

$$V_C = V_R + A_C + VDF$$

Herein,

V_C : corrected voltage amplitude

V_R : reading voltage amplitude

A_C : attenuation caused by cable loss

VDF : voltage division factor of AMN or ISN

The “**Margin**” column of the following data tables indicates the degree of compliance within the applicable limit. For example, a margin of 7dB means the emission is 7dB below the limit. The equation for margin calculation is as follows:

$$\text{Margin} = \text{Limit} - \text{Corrected Amplitude}$$

Test Results Summary

According to the recorded data in following table, the EUT complied with the FCC Part 15 B Class B.

Test Data

Environmental Conditions

Temperature:	24.6°C
Relative Humidity:	50%
ATM Pressure:	100.8 kPa

The testing was performed by Alex You on 2018-01-08.

Test Mode: Data communication with RJ45 port

AC120V, 60Hz, Line:

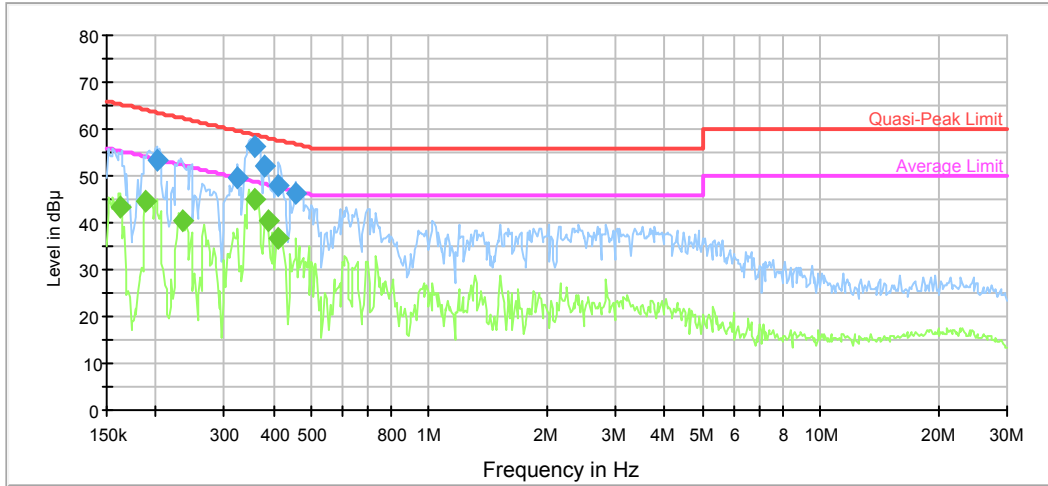

Frequency (MHz)	QuasiPeak (dBµV)	Bandwidth (kHz)	Line	Corr. (dB)	Margin (dB)	Limit (dBµV)	Comment
0.201433	53.2	9.000	L1	10.6	10.4	63.6	Compliance
0.324910	49.7	9.000	L1	10.1	9.9	59.6	Compliance
0.360371	56.1	9.000	L1	10.0	2.6	58.7	Compliance
0.378019	51.9	9.000	L1	10.0	6.4	58.3	Compliance
0.412647	48.0	9.000	L1	10.0	9.6	57.6	Compliance
0.457684	46.1	9.000	L1	9.9	10.6	56.7	Compliance

Frequency (MHz)	Average (dBµV)	Bandwidth (kHz)	Line	Corr. (dB)	Margin (dB)	Limit (dBµV)	Comment
0.162441	43.5	9.000	L1	11.0	11.8	55.3	Compliance
0.188994	44.5	9.000	L1	10.7	9.6	54.1	Compliance
0.234359	40.2	9.000	L1	10.4	12.1	52.3	Compliance
0.357511	45.2	9.000	L1	10.0	3.6	48.8	Compliance
0.387164	40.5	9.000	L1	10.0	7.6	48.1	Compliance
0.412647	36.5	9.000	L1	10.0	11.1	47.6	Compliance

AC120V, 60Hz, Neutral:

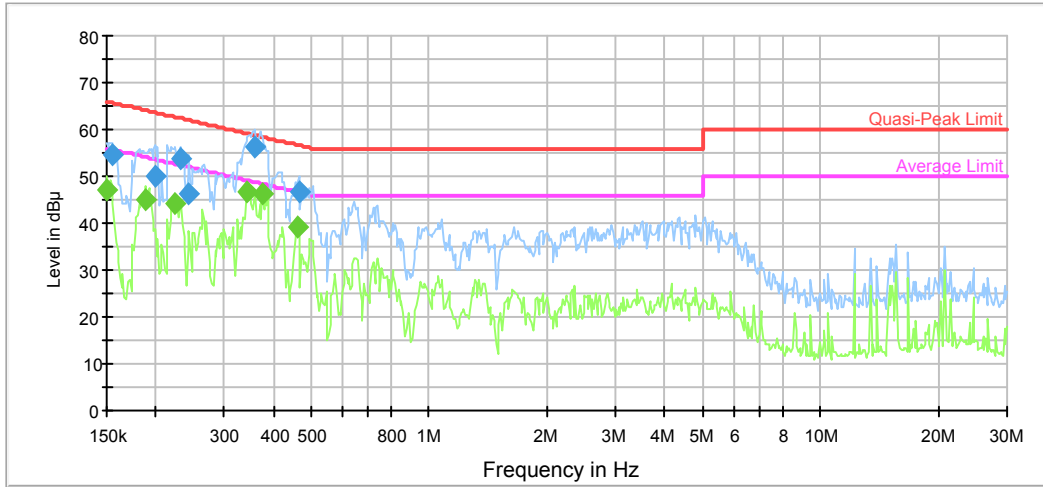

Frequency (MHz)	QuasiPeak (dBµV)	Bandwidth (kHz)	Line	Corr. (dB)	Margin (dB)	Limit (dBµV)	Comment
0.154858	54.6	9.000	N	11.1	11.1	65.7	Compliance
0.199835	49.8	9.000	N	10.6	13.8	63.6	Compliance
0.230654	53.8	9.000	N	10.4	8.6	62.4	Compliance
0.243884	46.1	9.000	N	10.4	15.9	62.0	Compliance
0.360371	56.4	9.000	N	10.0	2.3	58.7	Compliance
0.465037	46.8	9.000	N	9.9	9.8	56.6	Compliance

Frequency (MHz)	Average (dBµV)	Bandwidth (kHz)	Line	Corr. (dB)	Margin (dB)	Limit (dBµV)	Comment
0.150000	47.0	9.000	N	11.2	9.0	56.0	Compliance
0.188994	45.0	9.000	N	10.7	9.1	54.1	Compliance
0.225205	44.0	9.000	N	10.5	8.6	52.6	Compliance
0.340821	46.8	9.000	N	10.1	2.4	49.2	Compliance
0.375019	46.1	9.000	N	10.0	2.3	48.4	Compliance
0.461346	39.0	9.000	N	9.9	7.7	46.7	Compliance

FCC §15.109 - RADIATED SPURIOUS EMISSIONS

EUT Setup

Below 1GHz:

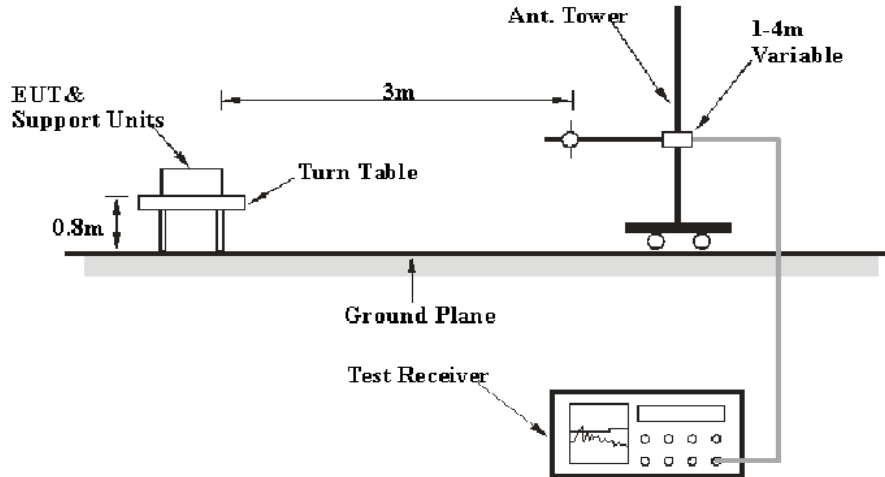

Above 1GHz:

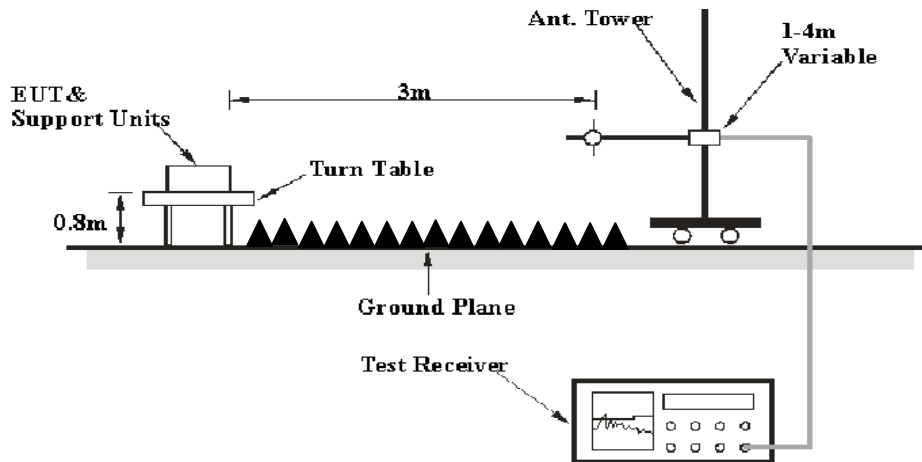

The radiated emission tests were performed in the 3 meters chamber test site for the range 30MHz to 1GHz and the 3 meters chamber test site for above 1GHz, using the setup accordance with the ANSI C63.4-2014. The specification used was the FCC Part 15.109 Class B limits.

EMI Test Receiver Setup

The system was investigated from 30 MHz to 14 GHz.

During the radiated emission test, the EMI test receiver was set with the following configurations:

Frequency Range	RBW	Video B/W	IF B/W	Measurement
30 MHz – 1000 MHz	120 kHz	300 kHz	120 kHz	QP
Above 1 GHz	1 MHz	3 MHz	/	Peak
	1 MHz	10 Hz	/	AVG

Test Procedure

During the radiated emissions, the adapter of laptop was connected to the first AC floor outlet and the other support equipments were connected to the second AC floor outlet.

Maximizing procedure was performed on the highest emissions to ensure that the EUT complied with all installation combinations.

The data was recorded in the Quasi-peak detection mode for below 1 GHz, peak and average detection mode above 1 GHz.

Test Equipment List and Details

Manufacturer	Description	Model	Serial Number	Calibration Date	Calibration Due Date
R&S	EMI Test Receiver	ESCI	100224	2017-09-01	2018-08-31
Sunol Sciences	Antenna	JB3	A060611-1	2017-11-10	2020-11-10
HP	Amplifier	8447D	2727A05902	2017-09-05	2018-09-05
Agilent	Spectrum Analyzer	E4440A	SG43360054	2017-12-08	2018-12-08
ETS-Lindgren	Horn Antenna	3115	000 527 35	2016-01-05	2019-01-04
MITEQ	Amplifier	AFS42-00101800-2 5-S-42	2001271	2017-09-05	2018-09-05
N/A	Coaxial Cable	C-NJNJ-50	C-0400-01	2017-09-05	2018-09-05
N/A	Coaxial Cable	C-NJNJ-50	C-0075-01	2017-09-05	2018-09-05
N/A	Coaxial Cable	C-NJNJ-50	C-1000-01	2017-09-05	2018-09-05
N/A	Coaxial Cable	C-SJSJ-50	C-0800-01	2017-09-05	2018-09-05
Farad	Test Software	EZ-EMC	V1.1.4.2	N/A	N/A

* **Statement of Traceability:** Bay Area Compliance Laboratories Corp. (Dongguan) attests that all calibrations have been performed, traceable to National Primary Standards and International System of Units (SI).

Corrected Amplitude & Margin Calculation

The Corrected Amplitude is calculated by adding the Antenna Factor and Cable Loss, and subtracting the Amplifier Gain from the Meter Reading. The basic equation is as follows:

$$\text{Corrected Amplitude} = \text{Meter Reading} + \text{Antenna Factor} + \text{Cable Loss} - \text{Amplifier Gain}$$

The “**Margin**” column of the following data tables indicates the degree of compliance with the applicable limit. For example, a margin of 7 dB means the emission is 7 dB below the limit. The equation for margin calculation is as follows:

$$\text{Margin} = \text{Limit} - \text{Corrected Amplitude}$$

Test Data

Environmental Conditions

Temperature:	21.7°C
Relative Humidity:	44 %
ATM Pressure:	102 kPa

** The testing was performed by Jim Zhang on 2018-01-02.*

Test Result: Compliance

Test Mode: Data communication with RJ45 port

1) Below 1GHz:

Horizontal

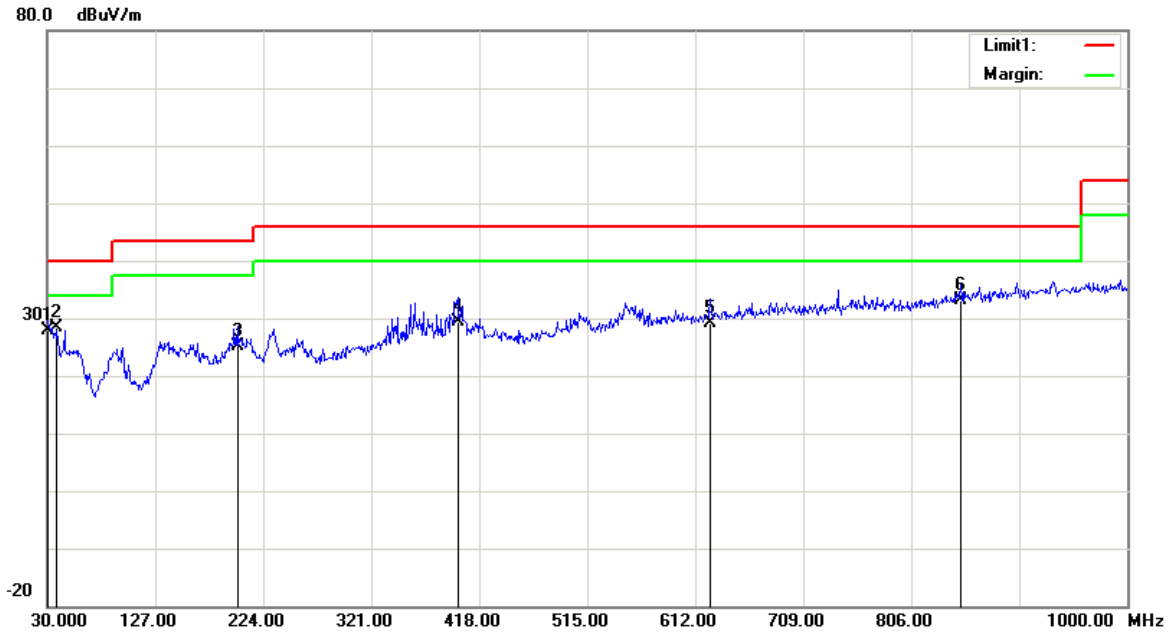

Frequency (MHz)	Receiver Reading (dBµV)	Detector	Correction Factor (dB/m)	Cord. Amp. (dBµV/m)	Limit (dBµV/m)	Margin (dB)
30.9700	30.30	QP	-2.30	28.00	40.00	12.00
37.7600	33.89	QP	-5.59	28.30	40.00	11.70
200.7200	31.73	QP	-6.63	25.10	43.50	18.40
398.6000	31.28	QP	-1.98	29.30	46.00	16.70
625.5800	25.71	QP	3.39	29.10	46.00	16.90
850.6200	26.25	QP	6.95	33.20	46.00	12.80

Vertical

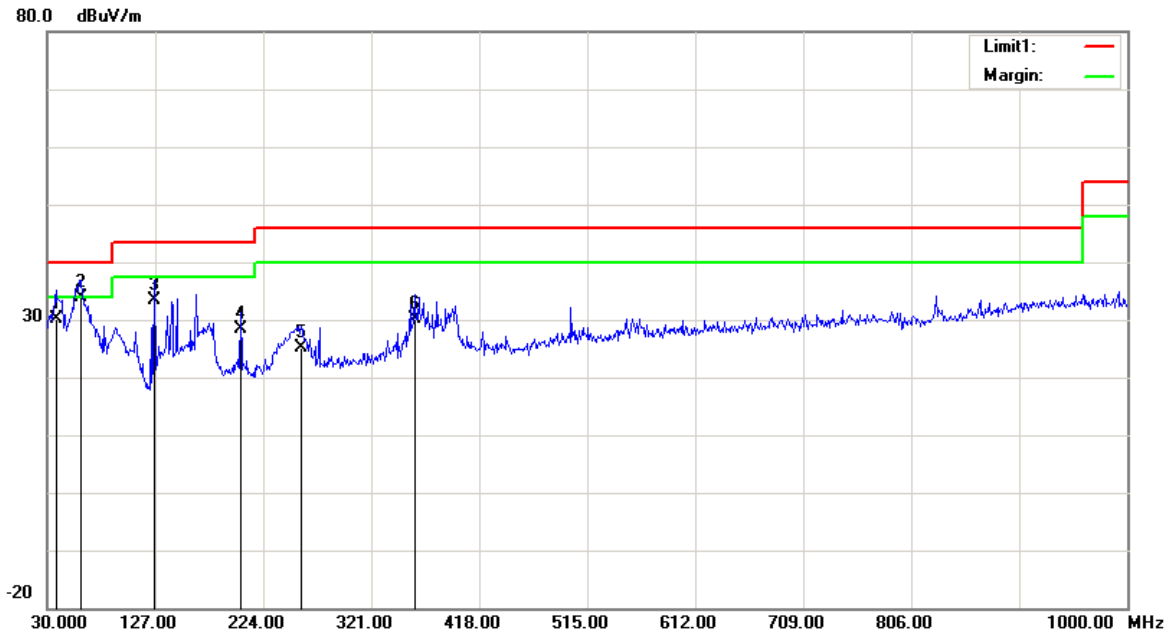

Frequency (MHz)	Receiver Reading (dBμV)	Detector	Correction Factor (dB/m)	Cord. Amp. (dBμV/m)	Limit (dBμV/m)	Margin (dB)
37.7600	35.69	QP	-5.59	30.10	40.00	9.90
60.0700	47.79	QP	-13.89	33.90	40.00	6.10
126.0300	41.77	QP	-8.37	33.40	43.50	10.10
203.6300	35.59	QP	-7.29	28.30	43.50	15.20
257.9500	31.74	QP	-6.64	25.10	46.00	20.90
359.8000	33.37	QP	-3.17	30.20	46.00	15.80

2) Above 1GHz:

Horizontal

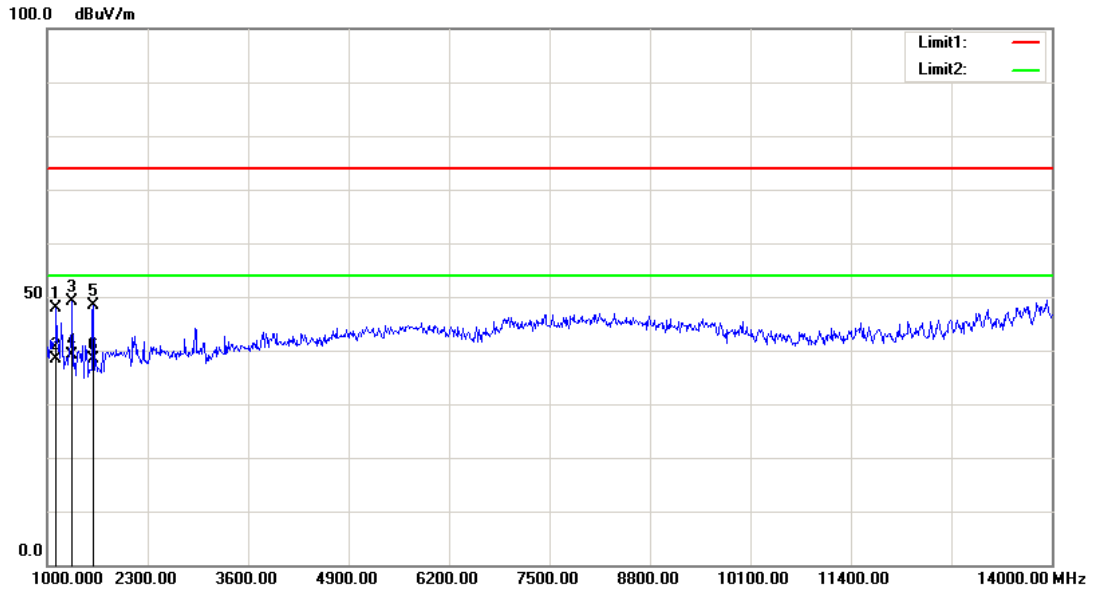

Frequency (MHz)	Receiver Reading (dBµV)	Detector	Correction Factor (dB/m)	Cord. Amp. (dBµV/m)	Limit (dBµV/m)	Margin (dB)
1117.000	58.22	peak	-10.23	47.99	74.00	26.01
1117.000	48.64	AVG	-10.23	38.41	54.00	15.59
1331.500	58.89	peak	-9.75	49.14	74.00	24.86
1331.500	48.76	AVG	-9.75	39.01	54.00	14.99
1598.000	57.17	peak	-8.73	48.44	74.00	25.56
1598.000	47.23	AVG	-8.73	38.50	54.00	15.50

Vertical

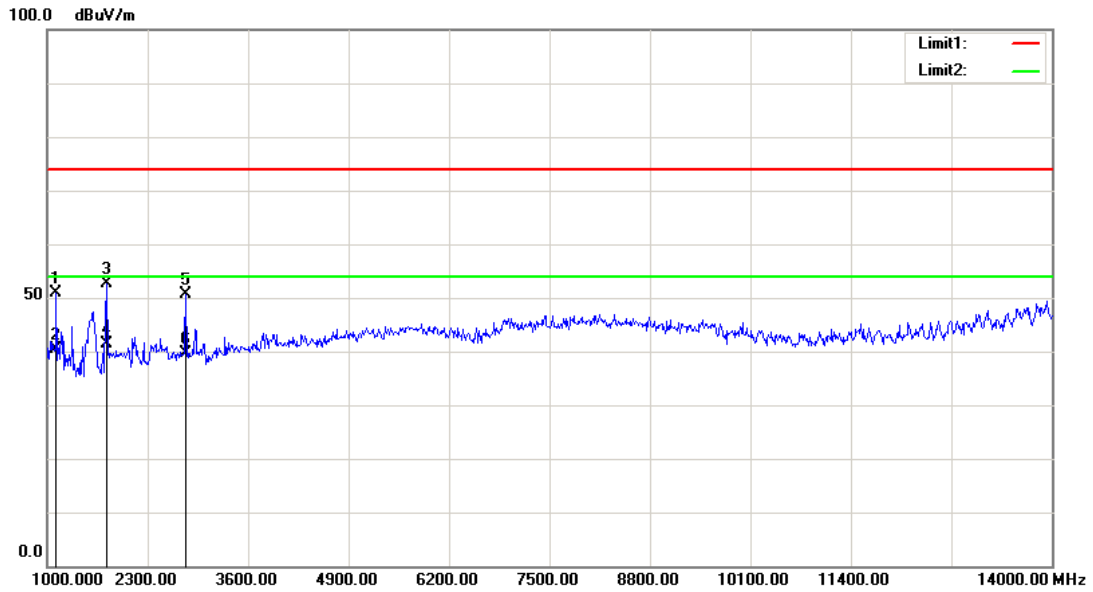

Frequency (MHz)	Receiver Reading (dBμV)	Detector	Correction Factor (dB/m)	Cord. Amp. (dBμV/m)	Limit (dBμV/m)	Margin (dB)
1117.000	61.22	peak	-10.23	50.99	74.00	23.01
1117.000	50.64	AVG	-10.23	40.41	54.00	13.59
1767.000	60.60	peak	-8.01	52.59	74.00	21.41
1767.000	49.35	AVG	-8.01	41.34	54.00	12.66
2800.500	55.83	peak	-5.24	50.59	74.00	23.41
2800.500	44.76	AVG	-5.24	39.52	54.00	14.48

END OF REPORT