

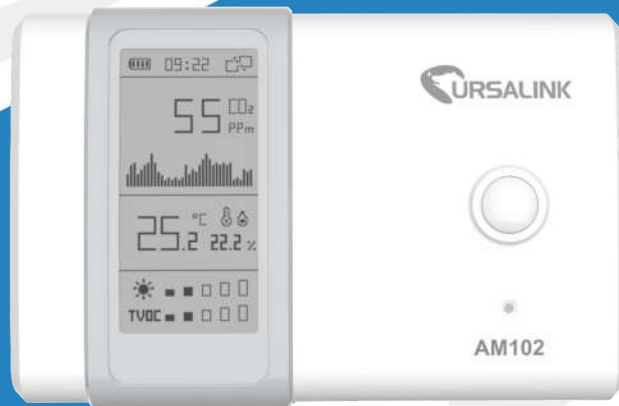

AM100 Series User Guide



Safety Precautions

Ursalink will not shoulder responsibility for any loss or damage resulting from not following the instructions of this operating guide.

- ❖ The device must not be disassembled or remodeled in any way.
- ❖ Do not place the device outdoors where the temperature is below/above operating range. Do not place the device close to objects with naked flames, heat source (oven or sunlight), cold source, liquid and extreme temperature changes.
- ❖ The device is not intended to be used as a reference sensor, and Ursalink will not should responsibility for any damage which may result from inaccurate readings.
- ❖ The battery should be removed from the device if it is not to be used for an extended period. Otherwise, the battery might leak and damage the device. Never leave a discharged battery in the battery compartment.
- ❖ The device must never be subjected to shocks or impacts.
- ❖ Do not clean the device with detergents or solvents such as benzene or alcohol. To clean the device, wipe with a soft moistened cloth. Use another soft, dry cloth to wipe dry.

Declaration of Conformity

Ursalink AM100 series is in conformity with the essential requirements and other relevant provisions of the CE, FCC, and RoHS. AM100 series contains AM102-915.



© 2017-2020 Xiamen Ursalink Technology Co., Ltd.

All rights reserved.

All information in this guide is protected by copyright law. Whereby, no organization or individual shall copy or reproduce the whole or part of this user guide by any means without written authorization from Xiamen Ursalink Technology Co., Ltd.

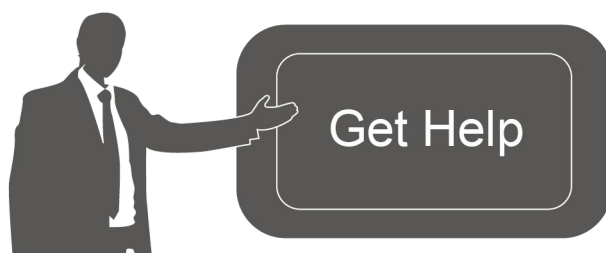

For assistance, please contact
Ursalink technical support:
Email: helpdesk@ursalink.com
Tel: 86-592-5023060
Fax: 86-592-5023065

Revision History

Date	Doc Version	Description
April 7, 2020	V 1.0	Initial version

Contents

1. Overview.....	5
1.1 Description.....	5
1.2 Features.....	5
1.3 Specifications.....	5
1.4 Dimensions(mm).....	7
2. Hardware Introduction.....	7
2.1 Packing List.....	7
2.2 Product Overview.....	7
3. Power Supply.....	8
3.1 Battery Installation.....	8
3.2 External Power Supply.....	8
4. Sensor Installation.....	9
4.1 PIR Detection Range.....	9
4.2 Installation Note.....	9
4.3 Wall Mounting.....	10
5. Turn ON/OFF the Sensor.....	10
5.1 Turn ON/OFF via Smartphone APP.....	11
5.2 Turn ON/OFF via PC Software.....	12
5.3 Turn ON/OFF via Button.....	13
6. Sensor Configuration.....	13
6.1 Configuration via Smartphone APP.....	13
6.1.1 Read Configuration.....	14
6.1.2 Write Configuration.....	14
6.1.3 Template Settings.....	15
6.2 Configuration via PC.....	17
6.2.1 Read Configuration.....	17
6.2.2 Write Configuration.....	18
6.2.3 Upgrade.....	18
6.2.4 Template and Reset.....	19
7. Sensor Parameters (for App and PC).....	21
7.1 LoRa WAN Settings.....	21
7.1.1 Basic Settings-OTAA.....	21
7.1.2 Basic Settings-ABP.....	22
7.1.3 Channel Settings.....	23
7.2 Device Settings.....	25
7.2.1 General.....	25
7.2.1 Data Collection.....	25
7.2.2 Data Calibration.....	26
7.2.3 Threshold.....	27
8. Sensor Management via Uursalink Cloud.....	27
8.1 Uursalink Cloud Registration.....	27

8.2 Add a Ursalink LoRaWAN Gateway.....	28
8.3 Add AM100/AM102 to Cloud.....	29



1. Overview

1.1 Description

AM100 series is a compact indoor ambience monitoring sensor including motion, humidity, temperature, light, TVOC, CO₂, barometric pressure for wireless LoRa network. AM100 series is a battery powered device and is designed to be wall-mounted. It is equipped with NFC (Near Field Communication) and can easily be configured via a smartphone or a PC software.

Sensor data are transmitted in real-time using standard LoRaWAN protocol. LoRaWAN enables encrypted radio transmissions over long distance while consuming very little power. The user can obtain sensor data and view the trend of data change through Uursalink Cloud or through the user's own Network Server.

1.2 Features

- Robust LoRa connectivity for indoor or HVAC environments
- Integrated multiple sensors like temperature, humidity, light, air quality, etc.
- Easy configuration via NFC
- Visual display via E-Ink screen
- Standard LoRaWAN support
- Uursalink Cloud compliant
- Low power consumption (about 1 year battery life)
- Standard AA alkaline battery

1.3 Specifications

Model	AM102	AM100
LoRaWAN		
Sensitivity	-147dBm @300bps	
Mode	OTAA/ABP Class A	
Antenna	Embedded Ceramic Antenna	
Sensors		
Temperature		
Range	-40°C to + 70°C	
Accuracy	0°C to + 70°C (+/- 0.3°C), -40°C to 0°C (+/- 0.6°C)	
Humidity		
Range	0% to 100% RH	
Accuracy	10% to 90% RH (+/- 3%), below 10% and above 90% RH (+/- 5%)	

PIR		
Detection Area	94 ° Horizontal, 82 ° Vertical	
Detection Distance	5 m	
Output Range	0-65535	
Light		
Range	60000 lux (Visible + IR, IR)	
Accuracy	±30%	
CO₂		
Range	400 - 5000 ppm	
Accuracy	±30 ppm or ±3 % of reading	
TVOC		
Range	0 - 60000 ppb	
Accuracy	±15 %	
Long-term Stability	1.3 % accuracy drift per year	
Barometric Pressure		
Range	300 - 1100 hPa (-40°C - 85°C)	
Accuracy	±1 hPa	
Display & Configuration		
Display	2.13-inch Black&White E-Ink Screen	
Configuration	1. Mobile APP via NFC 2. PC software via NFC or type-C USB port	
Physical Characteristics		
Power Supply	1. 2 × AA Alkaline battery 2. 5VDC type-C USB power supply	
Battery Life ¹	0.9-0.7 year	1.5-1.2 year
(10 min interval, SF7-SF10)	0.8-0.6 year (Smart Mode Disabled ²)	1.3-1 year(Smart Mode Disabled)
VOC Disabled	1.1-0.9 year	
	1-0.8 year(Smart Mode Disabled)	
Operating Temperature	0°C to +45°C	
Relative Humidity	0% to 100% (non-condensing)	
Dimension	105 × 70.4 × 21.2 mm (4.1 × 2.8 × 0.8 in)	
Mounting	Wall	

1. Battery life is indicative only.

2. Smart mode: PIR=0 and last 20mins, the screen will stop updating data. It's recommended open this mode.

1.4 Dimensions(mm)

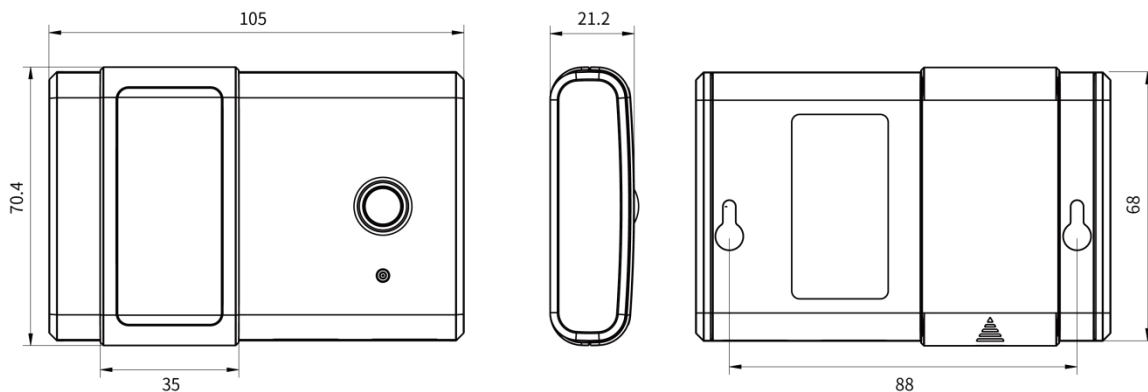

2. Hardware Introduction

2.1 Packing List

1 ×	2 ×	1 ×	2 ×	1 ×	1 ×
AM100/AM102	AA Batteries (LR6)	Mounting Sticker	Mounting Screws	Warranty Card	Quick Guide

! If any of the above items is missing or damaged, please contact your Ursalink sales representative.

2.2 Product Overview



Front Panel:

- ① E-ink screen
- ② NFC Area
- ③ LoRa Antenna (Internal)
- ④ PIR Sensor
- ⑤ Light Sensor

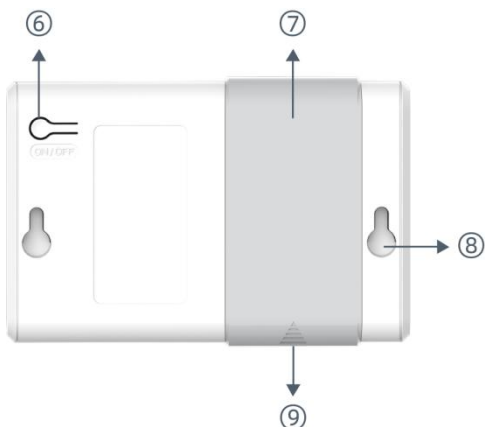

Back Panel:

- ⑥ Power button
- ⑦ Battery Cover
- ⑧ Mounting Holes
- ⑨ Type-C Port

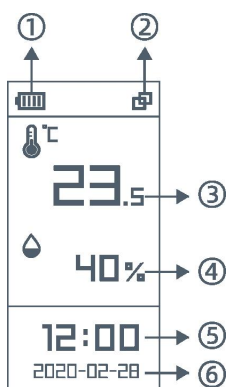

E-ink Screen:

- ① Battery Level
- ② Network Status
 - Activated
 - De-activated
- ③ Temperature
- ④ Humidity
- ⑤ Time
- ⑥ Date

3. Power Supply

3.1 Battery Installation

Remove the battery cover and install two new AA/LR6 batteries. Batteries can be replaced on the fly.

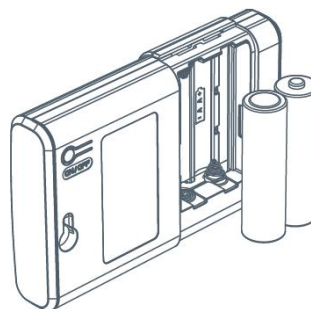
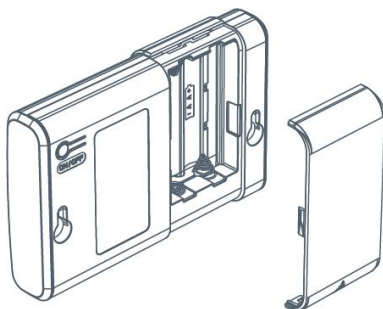

3.2 External Power Supply

AM100 series can be powered by type-C USB port (5V, 100mA). When battery and external power are both installed, external power will power the device first.

Note: External power can't be used for charging battery.

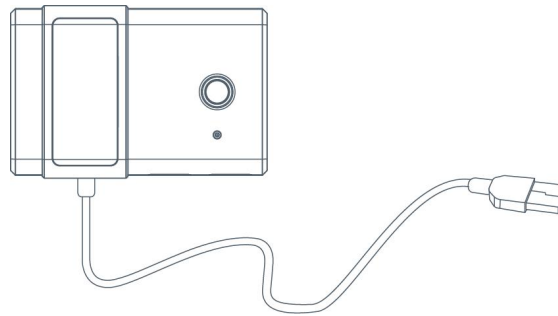

4. Sensor Installation

4.1 PIR Detection Range

There should not be any isolates or barriers in PIR detection range.

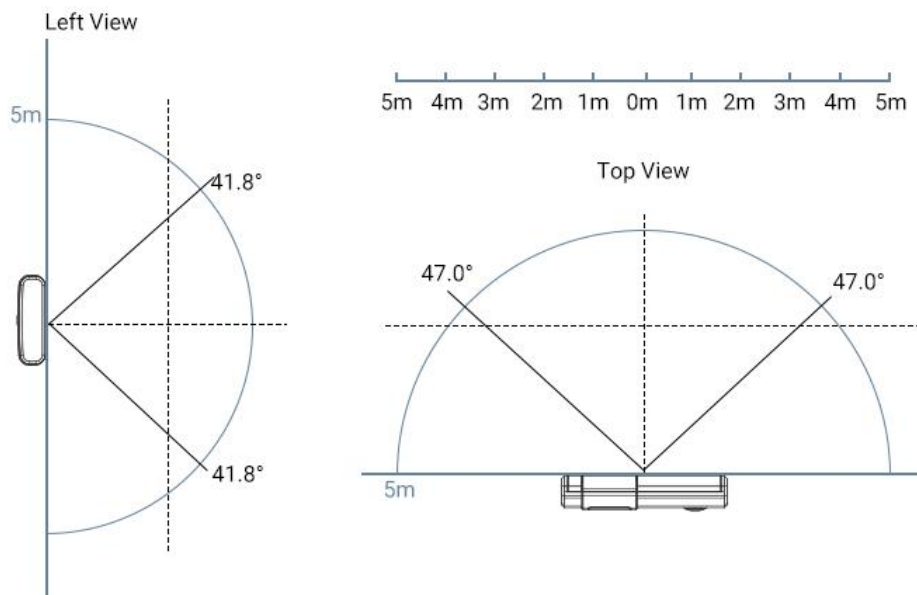

4.2 Installation Note

In order to ensure the best detection and LoRaWAN communication effect, it is recommended to install AM100 series as follows:

- There should not be any isolates or barriers in PIR and light detection range.
- Do not mount the device where the temperature is below/above operating range and temperature varies greatly.
- Stay far away from any heat source or cold source like oven, refrigerator.
- Do not mount the device close to where airflow varies greatly like windows, vent, fan and air conditioner.
- Do not mount the device upside down.
- Do not place the device right to the window or door. If you have to, you'd better pull the curtain.
- It is recommended to install at least 1.5m high from floor.

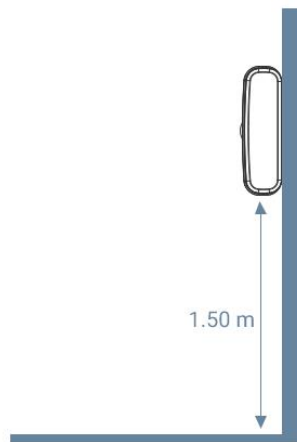

4.3 Wall Mounting

1. Attach the mounting sticker to the wall.
2. Mark the wall where the two mounting holes are according to the sticker's mark(around 88mm).

Note: The connecting line of two holes must be a horizontal line.

3. Drive two screws into wall at the marks using screw driver.
4. Mount the device on the wall.

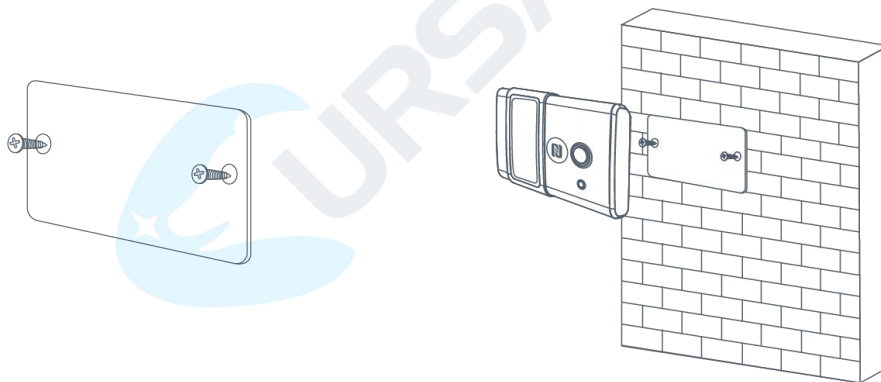

5. Turn ON/OFF the Sensor

AM100 series can be turned ON/OFF via smartphone or computer with NFC (Near Field Communication) or button. Select one of following methods to turn on/off the device.

Note: When AM100/AM102 is off, the screen statically displays the following information which will not consume power.



5.1 Turn ON/OFF via Smartphone APP

1. Download Ursalink configuration APP "Toolbox" and install it on your smartphone. The smartphone must support NFC.
2. Enable NFC on the smartphone and open the APP.
3. Attach the smartphone with NFC area to the device.

Note: Ensure the location of your smartphone NFC area and it is recommended to take off phone case before using NFC.

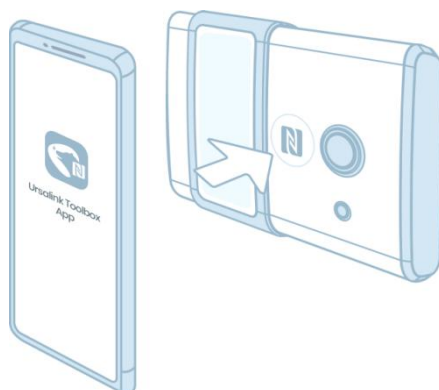

4. Device information will be shown on the APP.
5. Switch the button of Device Status to turn on or off the device.

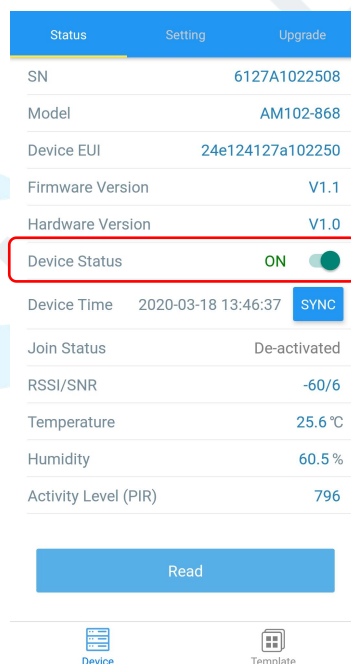

6. Enter password (default password: 123456) and wait a few seconds until APP shows "Operate Successful!".

Note: Keep the two devices close together and do not move them in order that you can get the best connectivity as possible when turning on or off via NFC. No response can be caused by long distance, wrong location or rapid movement.

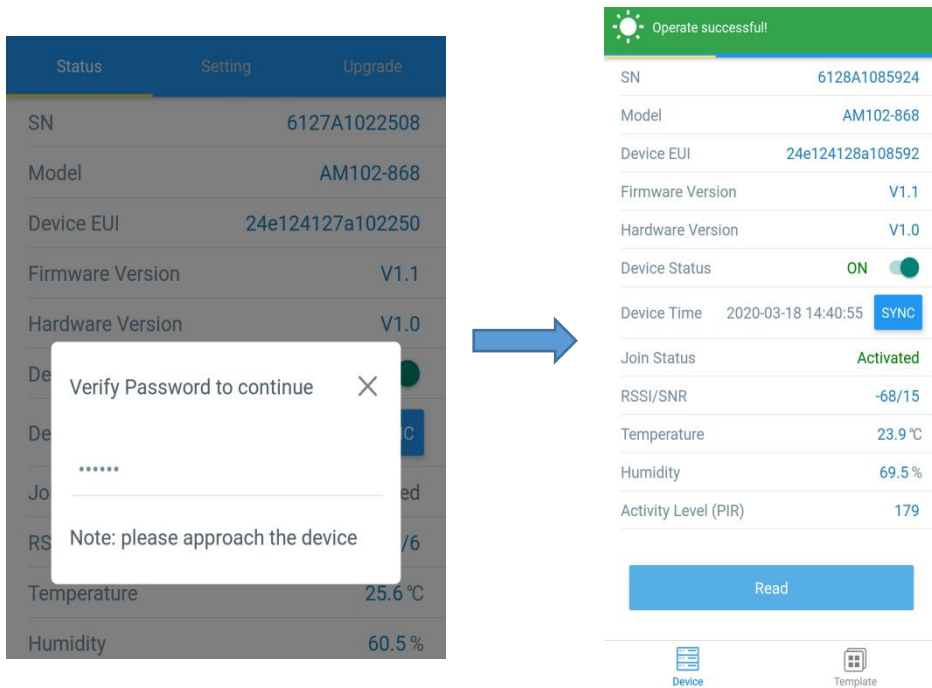

5.2 Turn ON/OFF via PC Software

1. Download Ursalink configuration software “Toolbox” and open the software.
2. Connect NFC reader to computer and attach the device to NFC reader.
3. Select type as NFC and serial port of NFC reader, then click “save”.

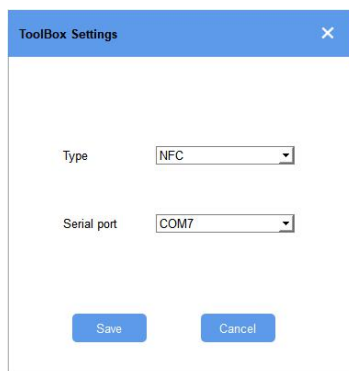
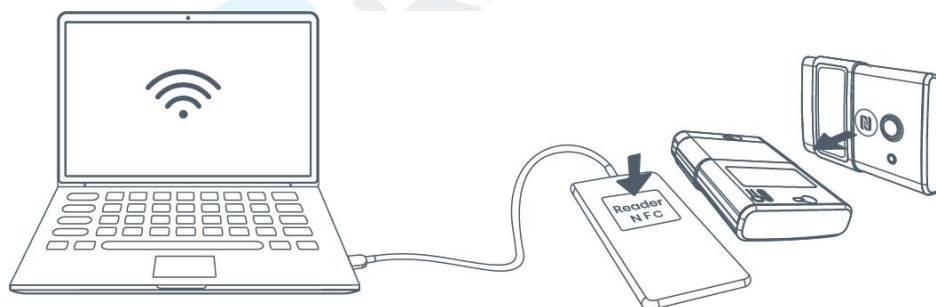

4. Device information will be shown on the software.



5. Click “Power On” to turn on the device or “Power Off” to turn off the device.

6. Enter password (Default password:123456) and press Enter key to change device status.

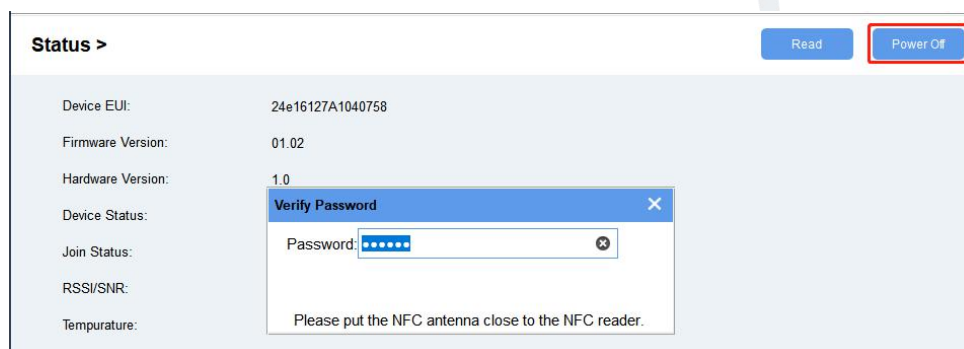

5.3 Turn ON/OFF via Button

Press and hold on the power button on the back panel for 3 to 10s to turn on or off the device. Press and hold on the power button on the back panel for over 10s to reset the device to factory default.

6.Sensor Configuration

Ursalink AM100 series sensors can be monitored and configured via NFC technology. In order to protect the security of sensor, password validation is required when turning on/off the sensor or changing configuration. Select one of the following ways to configure AM sensors.

6.1 Configuration via Smartphone APP

Make sure Ursalink Toolbox APP is downloaded and installed on your smartphone.

6.1.1 Read Configuration

1. Open APP “Toolbox” and click “Read” to read current information of device.

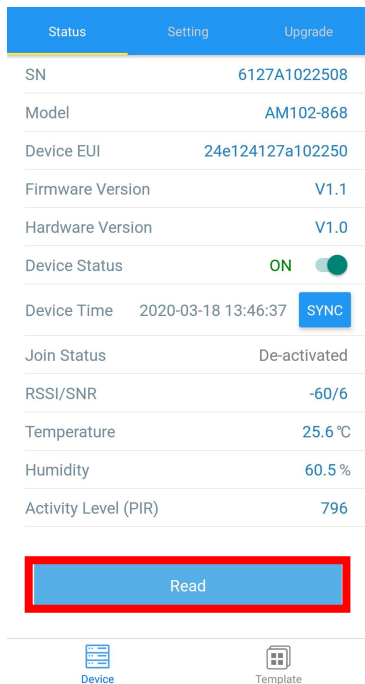

2. Attach the smartphone with NFC area to the device until the APP shows “Read Successful !”.

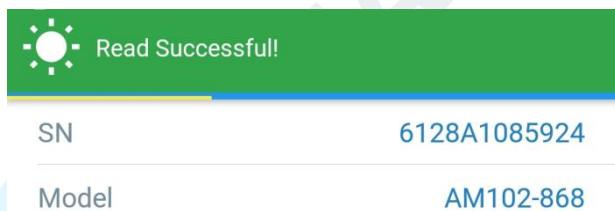

Note: “Read Failed!” can be caused by long distance, wrong location or rapid movement.

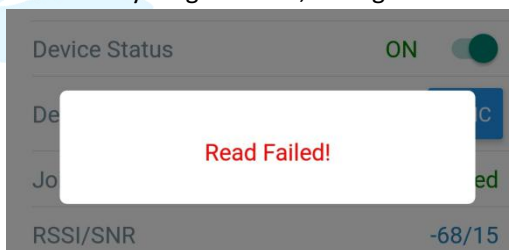

6.1.2 Write Configuration

1. Open APP “Toolbox” and go to “Settings” page.
2. Change parameters as required and click “Write”.

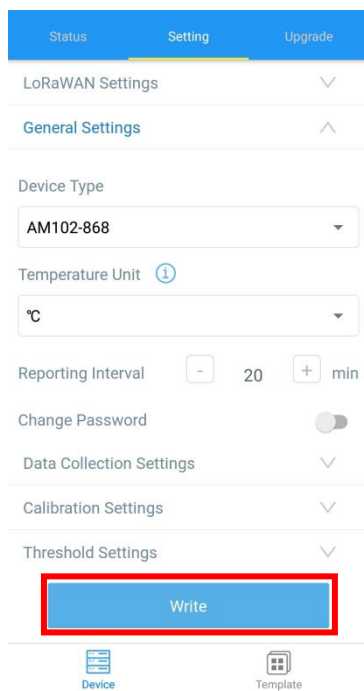

3. Enter password (default password: 123456).
 4. Attach the smartphone with NFC area to the device and wait a few seconds until APP shows "Write Successfully!". The device will automatically re-join the network if LoRaWAN paramters are changed.
- Note:** "Write Failed" can be caused by long distance, wrong location, or rapid movement.

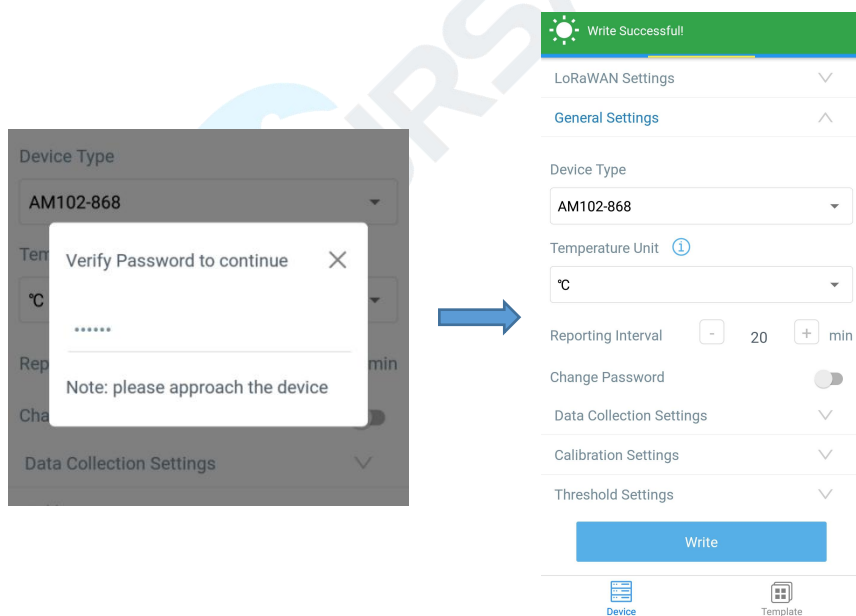

6.1.3 Template Settings

Template settings are used for easy and quick device configuration in bulk.

Note: Template function is allowed only for sensors with the same model and LoRa frequency band.

1. Go to "Template" page of APP and save current settings as a template.

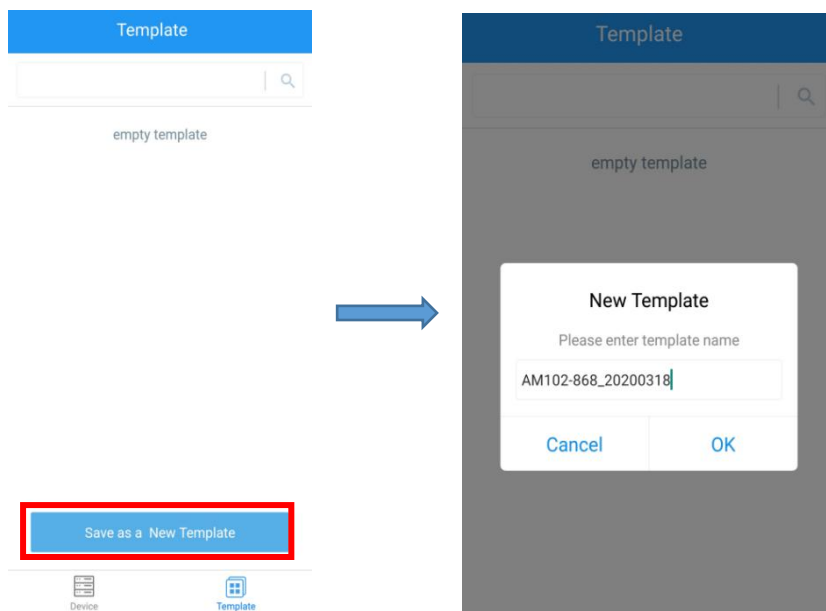

2. Attach the smartphone with NFC area to another device.
3. Select the template file from Toolbox and click "Write".

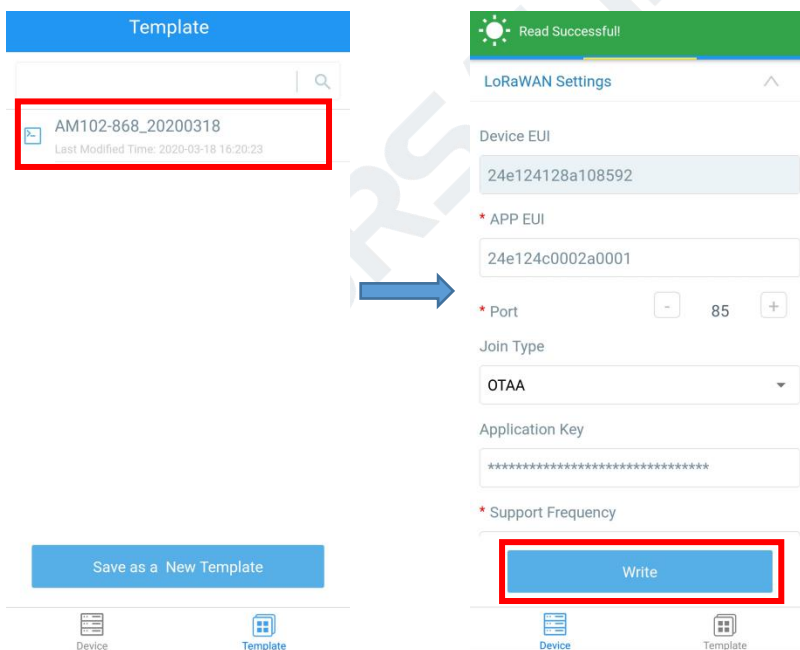

4. Enter password of this device and keep the two devices close until the APP shows "Write successful!".

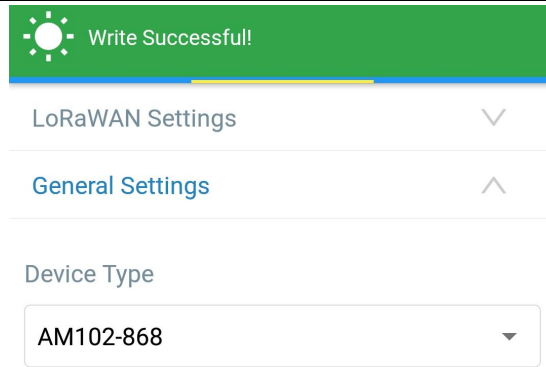

5. Slide the template item left to edit or delete the template.

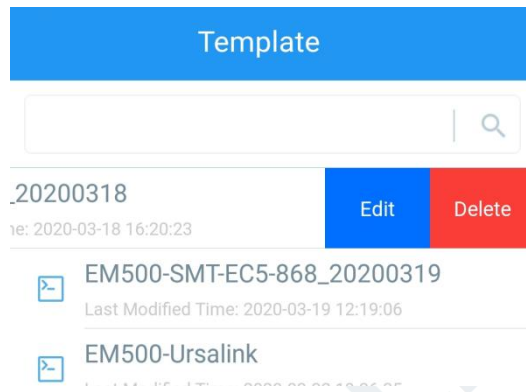

6.2 Configuration via PC

Make sure “Toolbox” is downloaded on your computer.

6.2.1 Read Configuration

1. Open software “Toolbox” and click “Read” to read current information of device.

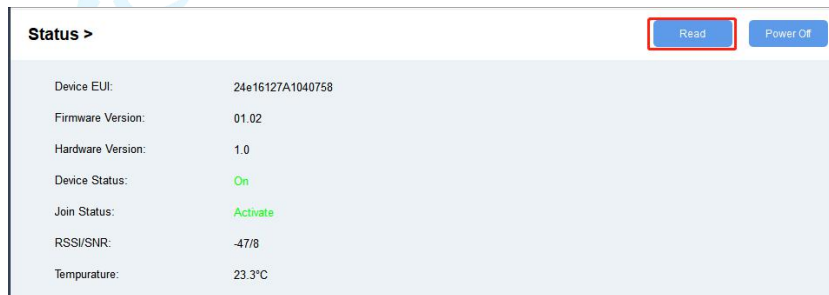

2. Attach the device to the NFC reader until Toolbox shows “success”.

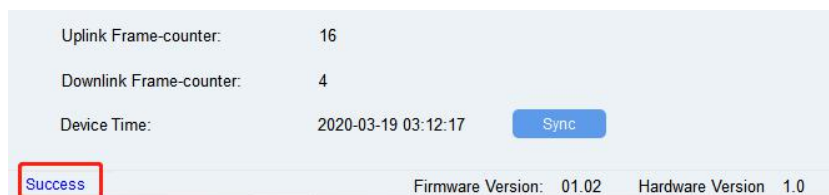

Note: Failing to read can be caused by long distance, wrong location, or rapid movement.

Device Time:	2020-03-19 03:10:40	Sync
Fail	Firmware Version:	01.02

6.2.2 Write Configuration

1. Go to “Settings” page to change parameters as requirements and click “save”.
2. Click “Write” and enter the correct password (default password: 123456).

3. Press Enter key to write and attach the device close to NFC reader until “Write” button disappear. The device will automatically re-join the network if LoRaWAN paramters are changed.

Note: Keep the two devices close and don’t move them in order that you can get the best connectivity as possible when writing data via NFC. Bad connection can be caused by long distance, wrong location, or rapid movement.

6.2.3 Upgrade

6.2.3.1 Upgrade Locally

1. Download AM firmware to your computer.
2. Go to “Maintenance -> Upgrade” page of Toolbox.
3. Click “Browse” and select the firmware from computer.
4. Click “Upgrade” and enter password of the device.
5. Press Enter key to start upgrade. Device will check if the firmware is correct. If it is correct, firmware will be imported to the device to upgrade.

Note: Keep the two devices close and don't move them in order that you can get the best connectivity as possible when upgrading. Failing to upgrade can be caused by long distance, wrong location, or rapid movement.

Upgrade >

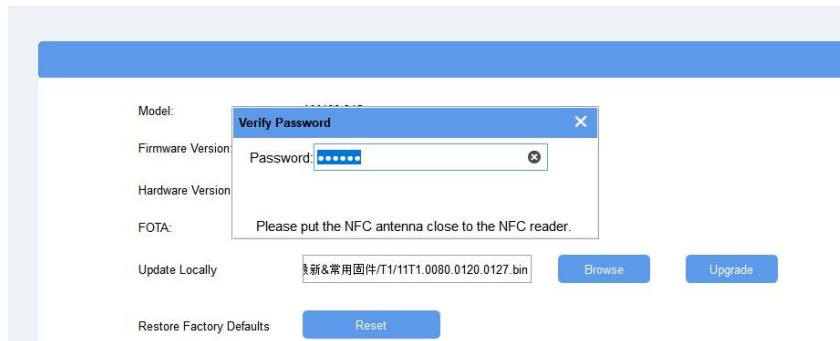

The screenshot shows the Upgrade page with a 'Verify Password' dialog box overlaid. The dialog box has a title bar 'Verify Password' and a close button. It contains a 'Password:' label and a password input field with a toggle icon. Below the input field, it says 'Please put the NFC antenna close to the NFC reader.' The background page shows fields for Model, Firmware Version, Hardware Version, FOTA, Update Locally (with a file path), and Restore Factory Defaults (with a Reset button).

6.2.3.2 FOTA

1. Make sure your computer can access the Internet.
2. Click "Check for Updates" to search for the latest firmware via computer Internet and upgrade.

Note: Keep the two devices close and don't move them in order that you can get the best connectivity as possible when upgrading. Failing to upgrade can be caused by long distance, wrong location, or rapid movement.

Upgrade >

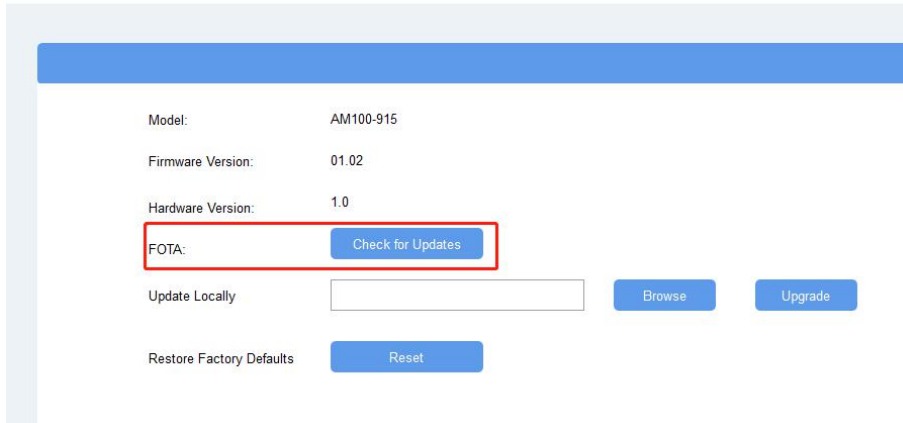

The screenshot shows the Upgrade page with the following information displayed: Model: AM100-915, Firmware Version: 01.02, Hardware Version: 1.0. The FOTA section has a 'Check for Updates' button highlighted with a red box. Below this are fields for Update Locally and Restore Factory Defaults (with a Reset button).

6.2.4 Template and Reset

6.2.4.1 Template Configuration

1. Go to "Maintenance -> Template and Reset" page of Toolbox.
2. Click "Export" to save the current settings as a template.

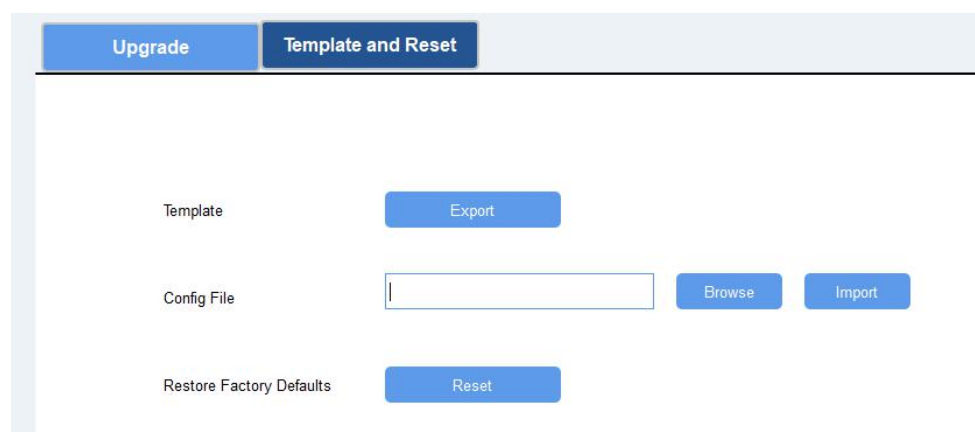

Upgrade	Template and Reset
Template	Export
Config File	<input type="text"/> Browse Import
Restore Factory Defaults	Reset

3. Click "Browse" to select the correct template from computer.
4. Click "Import" to import the template to the device.

6.2.4.2 Reset

Click the "Reset" to reset the setting to factory default.

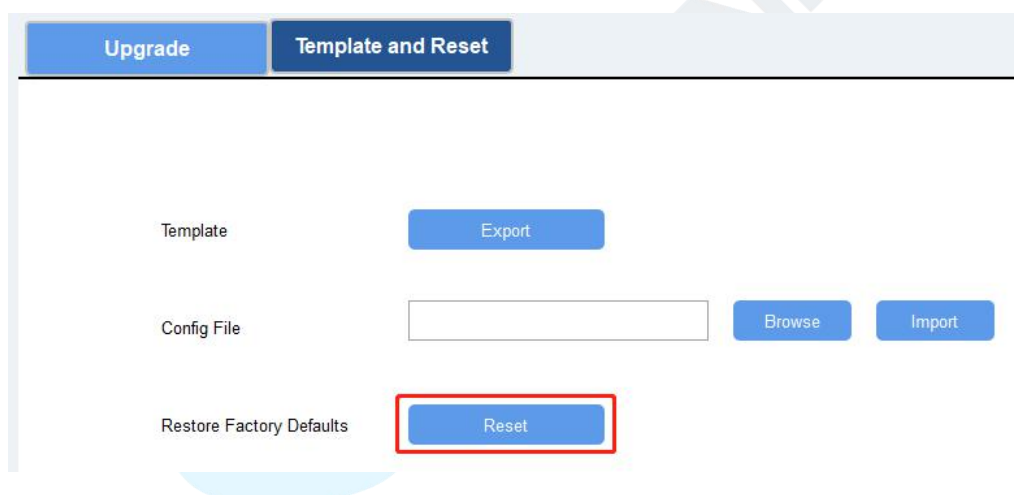

Upgrade	Template and Reset
Template	Export
Config File	<input type="text"/> Browse Import
Restore Factory Defaults	Reset

7. Sensor Parameters (for App and PC)

7.1 LoRa WAN Settings

7.1.1 Basic Settings-OTAA

Location:

Ursalink ToolBox (PC): LoRaWAN Settings → Basic

Ursalink ToolBox (APP): Device → Settings → LoRaWAN Settings

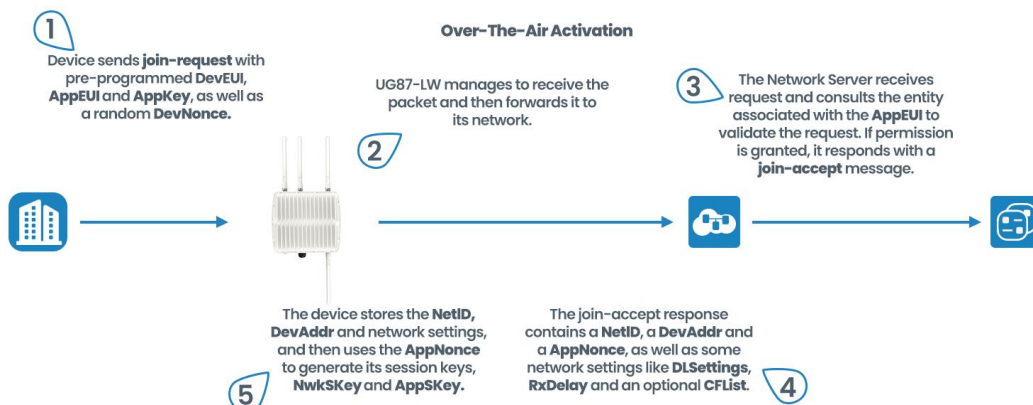

Basic Settings-OTAA		
Item	Description	Default
App EUI	Enter the application EUI. The Network Server receives request and consults the entity associated with the APP EUI to validate the request. If permission is granted, it responds with a join-accept message.	24e124c000 2a0001
Join Type	Select from: "OTAA" and "ABP". OTAA: Over-the-Air Activation. For over-the-air activation, end-devices must follow a join procedure prior to participating in data exchanges with the network server. An end-device has to go through a new join procedure every time it loses the session context information. ABP: Activation by Personalization. Under certain circumstances, end-devices can be activated by personalization. Activation by personalization directly ties an end-device to a specific network by-passing the join request - join accept procedure.	OTAA
Application Key	Enter the application key. Whenever an end-device joins a network via over-the-air activation, the application key is used to derive the Application Session key.	5572404c69 6e6b4c6f526 1323031382 3

Confirmed Mode	<p>After sending the attribute/data/battery packets to the network server, the device will resend these packets if it does not receive ACK bit from the Network Server.</p> <p>Note: If the device doesn't receive ACK for a long time, the device will resend confirmed packets 3 times at most. However, the device will resend attribute package all the time.</p>	Disabled
ADR	<p>ADR : Adaptive Data Rate.</p> <p>Enabled: The Network Server will adjust the datarate by MAC command.</p> <p>Disabled: Whatever how the signal quality is, the Network Server will not adjust the datarate of the device.</p>	Enabled

7.1.2 Basic Settings-ABP

Location:

Ursalink ToolBox (PC): LoRaWAN Settings → Basic

Ursalink ToolBox (APP): Device → Settings → LoRaWAN Setting

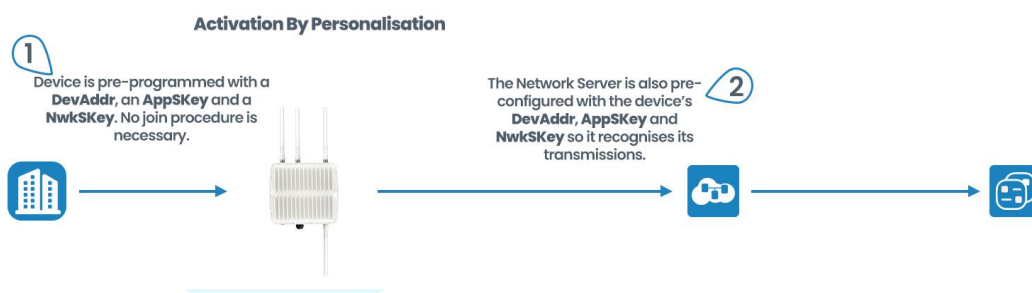

Basic Settings-ABP		
Item	Description	Default
App EUI	Enter the application EUI. The Network Server receives request and consults the entity associated with the APP EUI to validate the request. If permission is granted, it responds with a join-accept message.	24e124c0002 a0001
Join Type	<p>Select from: "OTAA" and "ABP".</p> <p>OTAA: Over-the-Air Activation.</p> <p>For over-the-air activation, end-devices must follow a join procedure prior to participating in data exchanges with the network server. An end-device has to go through a new join procedure every time it has lost the session context information.</p> <p>ABP: Activation by Personalization.</p>	OTAA

	Under certain circumstances, end-devices can be activated by personalization. Activation by personalization directly ties an end-device to a specific network by-passing the join request - join accept procedure.	
Device Address	Enter the device address. The device address identifies the end-device within the current network.	The last 8 digits number of SN
Network Session Key	Enter the network session key of the device. The network session key specific for the end-device. It is used by the end-device to calculate the MIC or part of the MIC (message integrity code) of all uplink data messages to ensure data integrity.	5572404c696 e6b4c6f5261 3230313823
Application Session Key	Enter the application session key of the device. The AppKey is an application session key specific for the end-device. It is used by both the application server and the end-device to encrypt and decrypt the payload field of application-specific data messages.	5572404c696 e6b4c6f5261 3230313823
Confirmed Mode	<p>After sending the attribute/data/battery packets to the network server, the device will resend these packets if it does not receive ACK bit from the Network Server.</p> <p>Note: If the device doesn't receive ACK for a long time, the device will resend confirmed packets 3 times at most. However, the device will resend attribute package all the time.</p>	Disabled
ADR	<p>ADR : Adaptive Data Rate.</p> <p>Enabled: The Network Server will adjust the datarate by MAC command.</p> <p>Disabled: Whatever how the signal quality is, the Network Server will not adjust the datarate of the device.</p>	Enabled

7.1.3 Channel Settings

Location:

Ursalink ToolBox (PC): LoRaWAN Settings → Channel

Ursalink ToolBox (APP): Device → Settings → LoRaWAN Settings

Note: Make sure the LoRa channel configuration of AM100 series matches the LoRaWAN gateway.

LoRa frequency configuration is as follows if the sensor LoRa frequency is one of EU433/EU868/RU864/IN865/AS923/KR920:

LoRa frequency configuration is as follows if the sensor LoRa frequency is one of CN470/US915/AU915:

Index	Frequency/MHz
0 - 15	902.3 - 905.3
16 - 31	905.5 - 908.5
32 - 47	908.7 - 911.7
48 - 63	911.9 - 914.9
64 - 71	903.9 - 914.2

Enter the index of the channel to be enabled in the input box, separated by commas.

Example:

- 1, 40: Enable Channel 1 and Channel 40
- 1-40: Enable Channel 1 to Channel 40
- 1-40, 60: Enable Channel 1 to Channel 40 and Channel 60
- All: Enable all channels
- Null: Indicates that all channels are disabled

Note:

For US915:
 64 channels numbered 0 to 63 utilize LoRa 125 kHz BW starting at 902.3 MHz and incrementing linearly by 0.2 MHz to 914.9.

8 channels numbered 64 to 71 utilize LoRa 500 kHz BW starting at 903.0 MHz and incrementing linearly by 1.6 MHz to 914.2.

For AU915:

64 channels numbered 0 to 63 utilize LoRa 125 kHz BW starting at 915.2 MHz and incrementing linearly by 0.2 MHz to 927.8.

8 channels numbered 64 to 71 utilize LoRa 500 kHz BW starting at 915.9 MHz and incrementing linearly by 1.6 MHz to 927.1.

For CN470:

80 channels numbered 0 to 79 utilize LoRa 125 kHz BW starting at 470.3 MHz and incrementing linearly by 0.2 MHz to 486.1.

16 channels numbered 80 to 95 utilize LoRa 125 kHz BW starting at 486.3 MHz and incrementing linearly by 1.6 MHz to 489.3.

7.2 Device Settings

7.2.1 General

Location:

Ursalink ToolBox (PC): Device Settings → General

Ursalink ToolBox (APP): Device → Settings → General Settings

Device General Settings		
Item	Description	Default
Device Type	Show the type of the device.	Null
Reporting Interval	The sensor reports the sampling data at regular intervals. Range: 5-30 (mins)	10
Screen Smart Mode	Screen display stops updating data for power saving. When Activity Level (PIR) = 0 and lasts for 20 minutes, screen will go to sleep mode until detected Activity Level (PIR) > 0.	Enabled
Temperature Unit	Configure the unit of temperature shown on the screen and status page. Note: Threshold settings should be changed after changing unit.	°C
Change Password	Change the password used for changing device status and writing configuration.	Disabled

7.2.1 Data Collection

Select the items you need to collect or not to collect.

Location:

Ursalink ToolBox (PC): Device Settings → Data Collection Settings

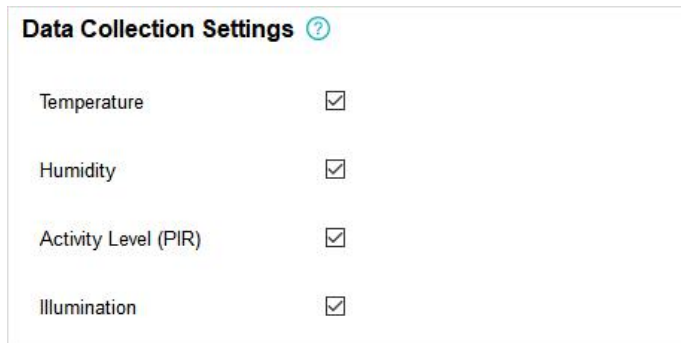

Ursalink ToolBox (APP): Device → Settings → Data Collection Settings

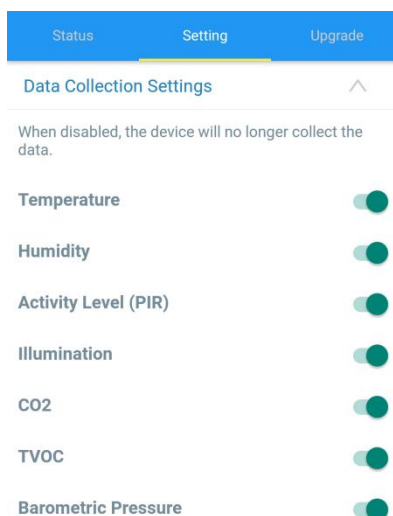

Note: The data displayed on the screen is the current value.
 The data reported to the gateway is the average of the reporting interval.

7.2.2 Data Calibration

Location:

Ursalink ToolBox (PC): Device Settings → Data Calibration Settings

Ursalink ToolBox (APP): Device → Settings → Data Calibration Settings

Data Calibration Settings		
Item	Description	Default
Enable	Enable calibration.	Disable
Current Raw Value	The current value.	Null
Calibration Value	The error value used for calibration. Range: -65535 to +65535	Null
Calibration button	Click to reset value to 0.	Null
Final Value	Adjusted value.	Null
Temperature Calibration	Enter the calibration value for temperature. Note: only one decimal is allowed.	Null

Humidity Calibration	Enter the calibration value for humidity. Note: only integer is allowed.	Null
Illumination Calibration	Enter the calibration value for illumination. Note: only integer is allowed.	Null
TVOC Calibration (AM102 Only)	Enter the calibration value for TVOC. Note: only integer is allowed.	Null
CO2 Calibration (AM102 Only)	Enter the calibration value for CO2. Note: only integer is allowed.	Null
Barometric Pressure Calibration (AM102 Only)	Enter the calibration value for barometric pressure. Note: only one decimal is allowed.	Null

Note: Calibration value should be re-configured if you re-start one item collection in Data Collection page.

7.2.3 Threshold

Location:

Ursalink ToolBox (PC): Device Settings → Threshold Settings

Ursalink ToolBox (APP): Device → Settings → Threshold Settings

Threshold Settings		
Item	Description	Default
Temperature	Enable: The device will send the latest temperature value to Network Server if the temperature goes above/below temperature thresholds.	Disabled
Over	The maximum temperature threshold.	Null
Below	The minimum temperature threshold.	Null

Example: Set the "Lockout Time" for 10min, "Duration" for 5min.

The device will report the detected value immediately when the value reaches the threshold and last for 5mins. After that, the device will check the detected value every 10 mins, and report the value again if it reaches the threshold and last for 5mins.

8.Sensor Management via Ursalink Cloud

Ursalink cloud is a comprehensive platform that provides multiple services including device remote management and data visualization with the easiest operation procedures.

8.1 Ursalink Cloud Registration

Register and log in Ursalink Cloud.

Ursalink Cloud URL: <https://cloud.ursalink.com/login.html>

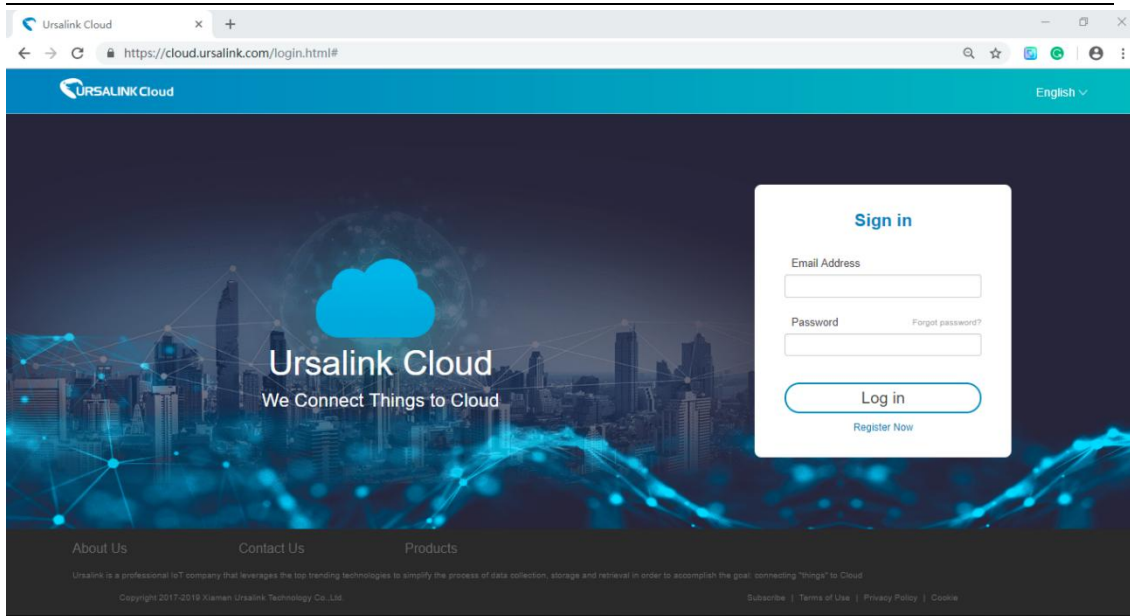

8.2 Add a Ursalink LoRaWAN Gateway

1. Enable “Ursalink” type network server and “Ursalink Cloud” mode in gateway web GUI.

Note: Ensure gateway has accessed the Internet.

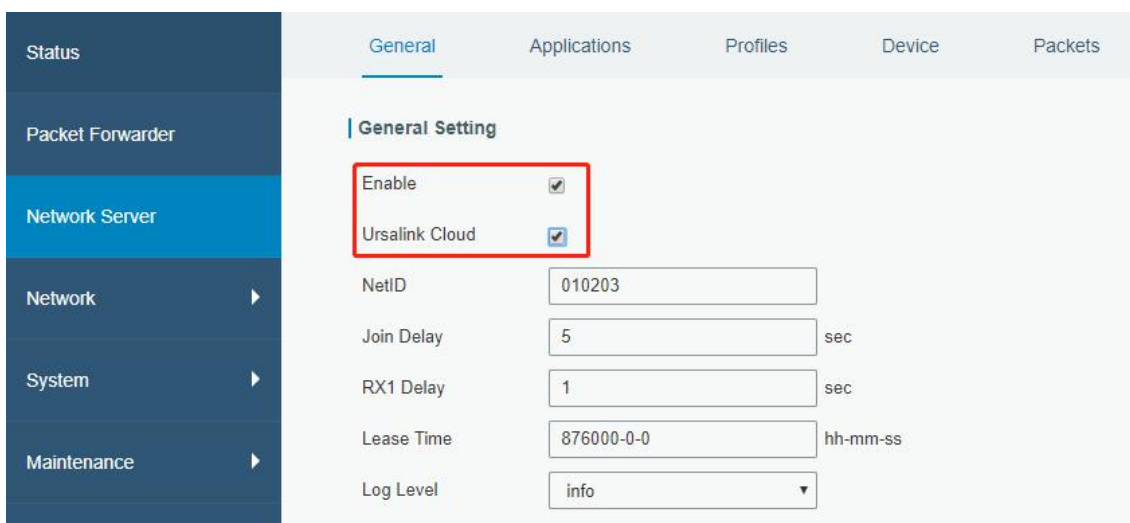
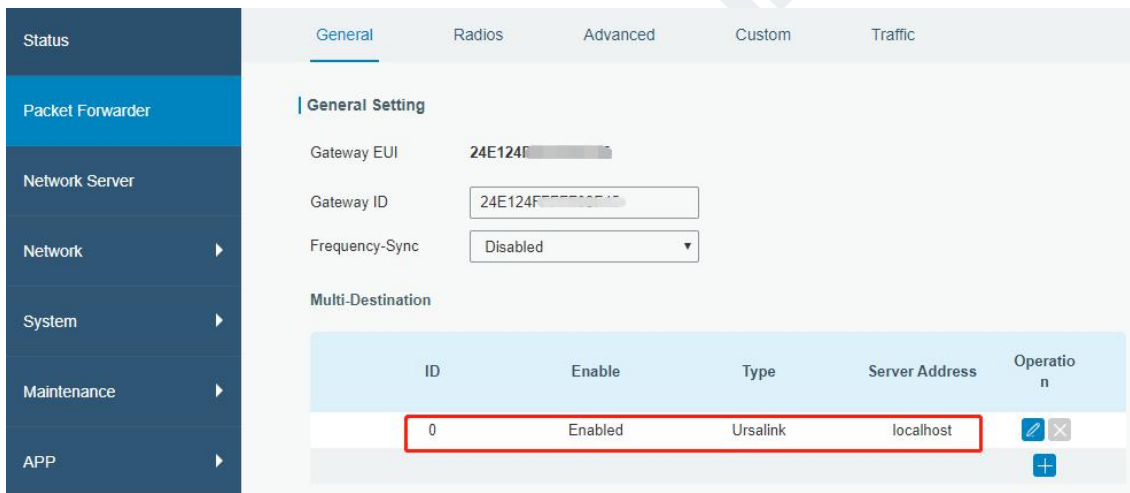

2. Go to “My Devices->Gateway” of Ursalink Cloud and click “Add” to add gateway to Ursalink Cloud via SN.

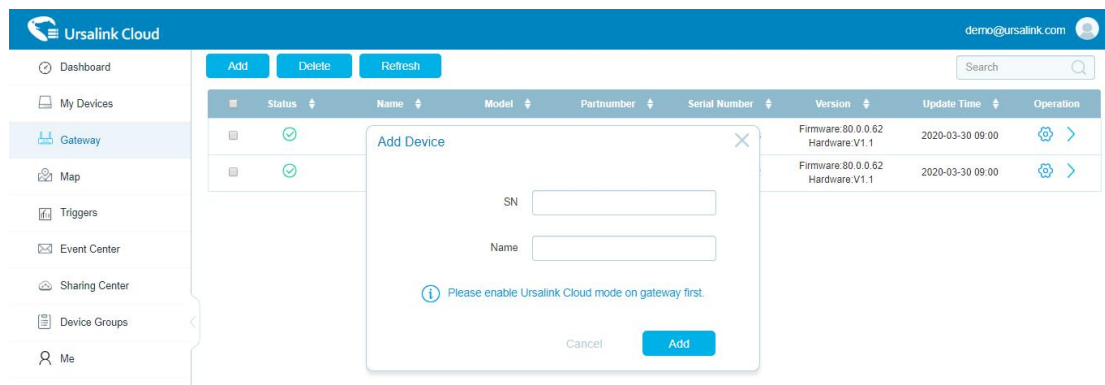

3. Check if gateway is online in Ursalink Cloud.

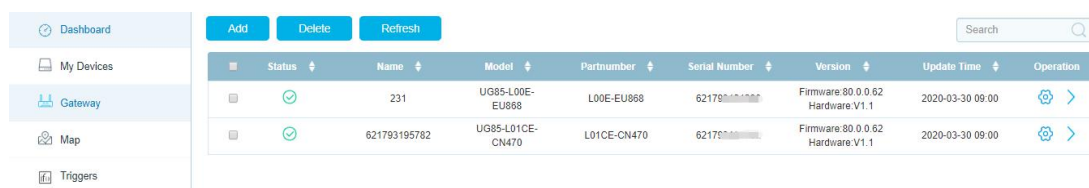

8.3 Add AM100/AM102 to Cloud

1. Go to “Device->My Devices” and click “Add Device”. Fill in the SN of EM500-SWL and select associated gateway.

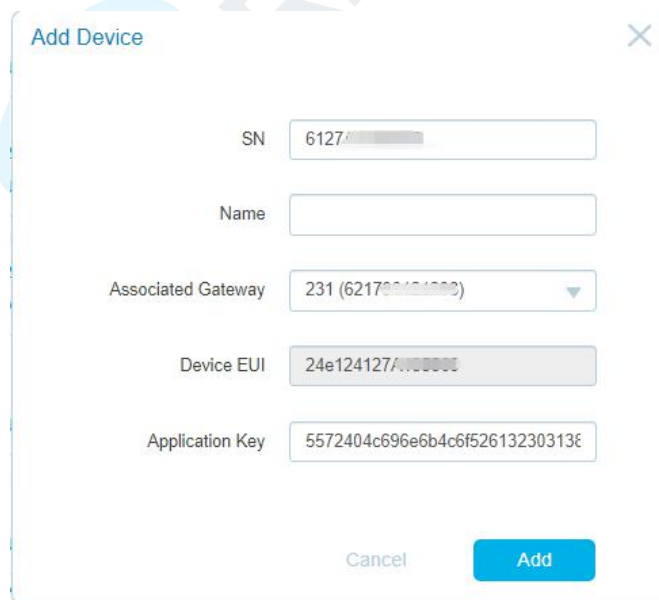

2. After AM100/AM102 is connected to Ursalink Cloud, Click > or “History Data” to check the data on Ursalink cloud.

The screenshot shows the Ursalink Cloud interface. On the left is a navigation menu with options: Dashboard, My Devices, Gateway, Map, Triggers, Event Center, Sharing Center, Device Groups, and Me. The main area displays a table of devices:

Status	Name	Interface Status	Update Time	Operation
ON	UC1114 Node I/O C... SN: 611683825791 Model: UC1114	DI 1: <input type="checkbox"/> DI 2: <input type="checkbox"/>	2020-04-07 20:49	
ON	1152 SN: 612293811165 Model: UC1152	DI_1: <input type="checkbox"/>	2020-04-07 20:27	
ON	AM100-Meeting Ro... SN: 6127A1358696 Model: AM100	Temper...: 21.5 °C Activity...: 93	2020-04-07 20:48	
	AM102 SN: 6128A1035795 Model: AM102	Temper...: 28.5 °C Activity...: 0 CO2: 624 ppm Barome...: 101.0 kPa	2020-04-07 16:38	

The detailed view for the AM100 device shows the following data:

- RSSI: -71dBm
- SNR: 8.5dB
- Battery: 0%
- Group Name: -
- Associated Gateway: 621793121298
- Device EUI: 24e124127A135869
- Firmware: v1.1
- Hardware: v1.0

A "History Data" graph is displayed, showing Temperature (blue), Humidity (orange), Activity Level (PIR) (green), and Illumination (red) over time from 03:57 to 20:48 on 04-07. The Activity Level shows significant spikes, reaching up to 500.

3. Go to "Dashboard" page to add dashboard.

The screenshot shows the Ursalink Cloud interface with the "Smart Office" dashboard selected. The dashboard includes several widgets:

- A large clock widget showing 20:55:11 on 2020-04-07.
- Two "UC1114 Node I/O Con..." widgets, both showing "ON" status.
- A "Meeting Room1-Illumi..." widget showing 15 lux.
- An "AM100-Meeting Room..." widget showing 21.5 °C.
- A "Meeting Room1-Humid..." widget showing 56.5%.
- A "Meeting Room1-Battery" widget showing 0%.
- A "Meeting Room1-Activit..." widget showing 93.
- An "Alarm List" widget with an "Intruder?" alert: "Condition A: AM100-Meeting Room1 (6127A1358696)'s Activity Level (PIR) is 93, greater than 10. Time Range: 18:00 - 08:45 (UTC+8), every day." The time is 2020-04-07 20:48:04.
- A "Temp Compare" widget showing a temperature of 25 °C.

The bottom of the dashboard features a "Meeting Room1" graph with Temperature (orange) and Humidity (blue) lines, and a "Temp Compare" graph with two temperature lines (orange and blue).

FCC Caution:

Any Changes or modifications not expressly approved by the party responsible for compliance could void the user's authority to operate the equipment.

This device complies with part 15 of the FCC Rules. Operation is subject to the following two conditions: (1) This device may not cause harmful interference, and (2) this device must accept any interference received, including interference that may cause undesired operation.

IMPORTANT NOTE:

Note: This equipment has been tested and found to comply with the limits for a Class B digital device, pursuant to part 15 of the FCC Rules. These limits are designed to provide reasonable protection against harmful interference in a residential installation. This equipment generates, uses and can radiate radio frequency energy and, if not installed and used in accordance with the instructions, may cause harmful interference to radio communications. However, there is no guarantee that interference will not occur in a particular installation. If this equipment does cause harmful interference to radio or television reception, which can be determined by turning the equipment off and on, the user is encouraged to try to correct the interference by one or more of the following measures:

- Reorient or relocate the receiving antenna.
- Increase the separation between the equipment and receiver.
- Connect the equipment into an outlet on a circuit different from that to which the receiver is connected.
- Consult the dealer or an experienced radio/TV technician for help.

FCC Radiation Exposure Statement:

This equipment complies with FCC radiation exposure limits set forth for an uncontrolled environment .This equipment should be installed and operated with minimum distance 20cm between the radiator& your body.

-END-