



Zhe Jiang DONGYANG DMEGC Chen ji Electronics CO., LTD

RoHS H/F

PRODUCT SPECIFICATION

Product Information	Description	A11 Single coil		
	Part No.	DM-TC5050A-45		
	DN			
	Designed	Checked	Approved	

Customer Information	Customer	
	Model	
	Part NO.	
	Customer Approved	

Address: Hengdian industrial Area, DongYang City, Zhejiang Province China

P.C: 322118

TEL: +0086-0579-86588315 (86588791)

FAX: +0086-0579-86553611



Important Notes:

1. If there is any argument on TX/Rx Coil Unit performance and/or life, judgment is to be made base on this specification only.
2. Customer has the responsibility to ensure that TX/Rx Coil Unit can satisfy the requirement of your application.
3. In the event that an official specification is not present by customer, this document will specify the agreed technical specification.
4. Within the limitation to satisfy this specification, DMEGC has the convenience to change the materials, size and shapes of components of the motor for the purpose of improving quality, and/or performance, and/or production efficiency.
5. After the receipt of this specification, customer should send a signed copy to DMEGC, before you issued purchase order for the confirmation on acknowledgement. DMEGC, regard it as the receipt of this specification acknowledged if customer fails to return the confirmation to us within the described period.

1.尺寸

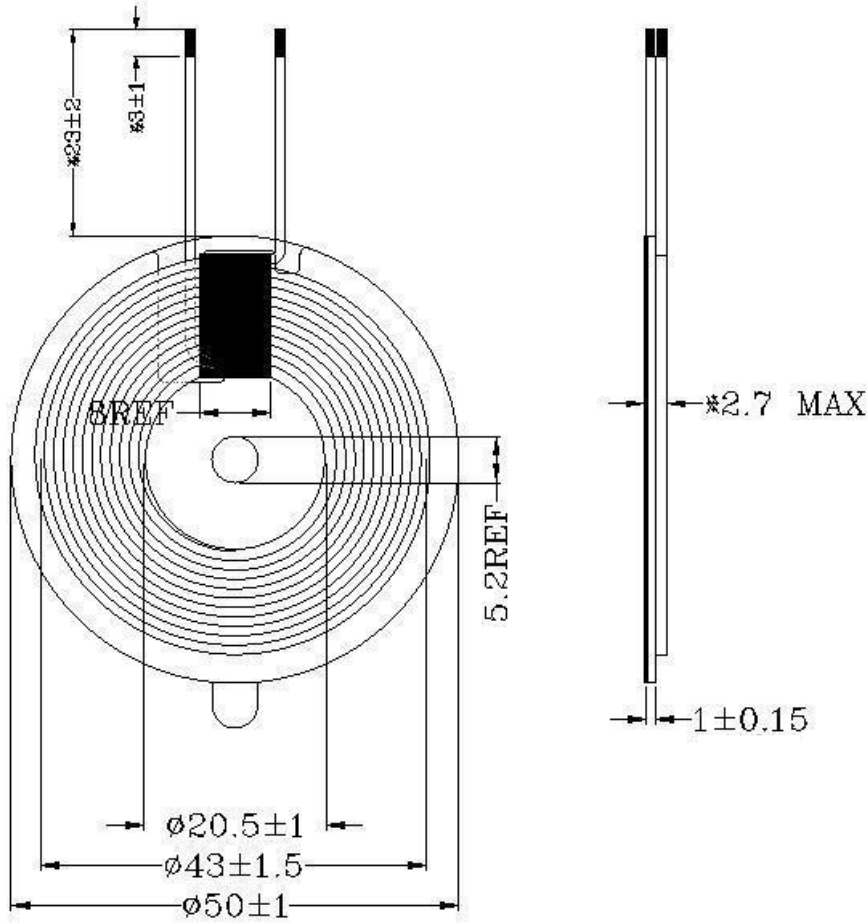

2.Winding parameter

No.	Line specification	Number of coils	Whether the trailing lines cross
1	0.08*105P	10Ts	YES



3. ELECTRICAL CHARACTERISTICS:

100KHz/1Vrms , TEMPERATURE:25±10°C, RELATIVE HUMIDITY:65±20%

No.	parameter	Measured value	Test equipment
1	Ls	6.3±10% uH	LCR
2	DCR	50 mΩ MAX	LCR
3	Q	70 MIN	LCR

4.BOM

BOM			
序号	物料名称	物料规格	UL FILE NO
1	Tin	High temperature tin strip	/
2	tape	High temperature resistant 8mm tape	E483388
3	coil	0.08*105P Silk-covered wire	E514717
4	Magnetic sheet	Manganese zinc ferrite	/
5	glue	Strong structural glue	/
6	Back glue	0.1Double-sided adhesive	/

5. The material conforms toRoHS and halogen-free standards

6、 Packing Specification

6-1

Pack 900 pcs in a carton.

6-2

The body specification of the carton is 405mm×295mm×320mm (900 pcs),.

6-3

Mark name of an article, type, quantity,

weight and factory name on the outside of the carton. Package Demonstration

