



**Shenzhen GTI Technology Co., Ltd.**

1-2/F., Building 2, Jiaquan Building, Guanlan High-Tech Park, Shenzhen, Guangdong, China

Tel: +86-755- 27521059

Fax: +86-755- 27521011

# TEST REPORT

**Product Name** ..... : Smart TV Box

**Trademark** ..... : N.A

**Model/Type reference** ..... : SS-1000

**Listed Model(s)** ..... : ATN ORIGINAL, ATN SILVER, ATN GOLD, ATN PLATINUM, ATN GERMANY, ATN TURKISH, ATN ALBANIAN, ATN HOLLAND, Stream TV, Sky Signal SS-100, SS-200, SS-300, SS-400, SS-500, SS-600, SS-700, SS-800, SS-900, SS-2000, SS-3000, SS-4000, SS-5000, SS-6000, SS-7000, SS-8000, SS-9000

**FCC ID** ..... : 2AORJSS1000

**Test Standards** ..... : **FCC Part 15.247: Operation within the bands 902-928 MHz, 2400-2483.5 MHz and 5725-5850 MHz**

**Report No.:** GTI20180004F

**Applicant** ..... : ATN Media Group FZ LLC.

**Address of applicant** ..... : Business Bay-alabry st Business Tower By Damac.office-807, Dubai/UAE.

**Date of Receipt** ..... : Jan. 12, 2018

**Date of Test Date**..... : Jan. 13, 2018- Jan. 18, 2018

**Data of issue.** ..... : Jan. 19, 2018

<b>Test result</b>	<b>Pass *</b>
--------------------	---------------

\* In the configuration tested, the EUT complied with the standards specified above

Shenzhen General Testing & Inspection Technology Co., Ltd.

1-2/F., Building 2, Jiaquan Building, Guanlan High-Tech Park, Shenzhen, Guangdong, China

Tel.: (86)755-27521059

Fax.: (86)755-27521011

Http://www.sz-ctc.org.cn



中国国家认证认可监督管理委员会  
Certification and Accreditation Administration of the People's Republic of China

For anti-fake verification, please visit the official website of Certification and Accreditation Administration of the People's Republic of China : [yz.cncaic.cn](http://yz.cncaic.cn)

GENERAL DESCRIPTION OF EUT	
Equipment:	Smart TV Box
Model Name:	SS-1000
Listed Model(s)	ATN ORIGINAL, ATN SILVER, ATN GOLD, ATN PLATINUM, ATN GERMANY, ATN TURKISH, ATN ALBANIAN, ATN HOLLAND, Stream TV, Sky Signal SS-100, SS-200, SS-300, SS-400, SS-500, SS-600, SS-700, SS-800, SS-900, SS-2000, SS-3000, SS-4000, SS-5000, SS-6000, SS-7000, SS-8000, SS-9000
Model Difference	All the models are the same circuit and RF module, except the mode names.
Manufacturer:	ATN Media Group FZ LLC.
Manufacturer Address:	Business Bay-alabrij st Business Towar By Damac.office-807, Dubai/UAE.
Power Rating:	Adapter: Input:100-240V AC, 50/60 Hz 0.7A MAX Output: 5VDC 2A

Compiled By:

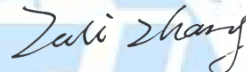

(Zaki Zhang)

Reviewed By:



(Gavin Shi)

Approved By:



(Walter Chen)

This test report may be duplicated completely for legal use with the approval of the applicant. It should not be reproduced except in full, without the written approval of our laboratory. The client should not use it to claim product endorsement by GTI. The test results in the report only apply to the tested sample. The test report shall be invalid without all the signatures of testing engineers, reviewer and approver. Any objections must be raised to GTI within 15 days since the date when the report is received. It will not be taken into consideration beyond this limit.

Shenzhen General Testing &amp; Inspection Technology Co., Ltd.

1-2/F., Building 2, Jiaquan Building, Guanlan High-Tech Park, Shenzhen, Guangdong, China

Tel.: (86)755-27521059

Fax.: (86)755-27521011

Http://www.sz-ctc.org.cn

中国国家认证认可监督管理委员会  
Certification and Accreditation Administration of the People's Republic of ChinaFor anti-fake verification, please visit the official website of Certification and Accreditation Administration of the People's Republic of China : [yz.cncaic.cn](http://yz.cncaic.cn)

## Table of Contents

## Page

<b>1. SUMMARY</b> .....	<b>4</b>
1.1. TEST STANDARDS.....	4
1.2. TEST DESCRIPTION.....	4
1.3. TEST FACILITY .....	5
1.4. MEASUREMENT UNCERTAINTY .....	5
<b>2. GENERAL INFORMATION</b> .....	<b>6</b>
2.1. ENVIRONMENTAL CONDITIONS .....	6
2.2. GENERAL DESCRIPTION OF EUT .....	6
2.3. DESCRIPTION OF TEST MODES .....	7
2.1. MEASUREMENT INSTRUMENTS LIST .....	8
<b>3. TEST CONDITIONS AND RESULTS</b> .....	<b>9</b>
3.1. CONDUCTED EMISSION MEASUREMENT.....	9
3.2. RADIATED EMISSION .....	15
3.3. MAXIMUM CONDUCTED OUTPUT POWER.....	19
3.4. POWER SPECTRAL DENSITY .....	23
3.5. 6dB BANDWIDTH.....	27
4.1. BAND EDGE COMPLIANCE OF RF EMISSION.....	30
4.2. ANTENNA REQUIREMENT.....	36
<b>5. EUT TEST PHOTO</b> .....	<b>37</b>
<b>6. PHOTOGRAPHS OF EUT CONSTRUCTIONAL</b> .....	<b>38</b>

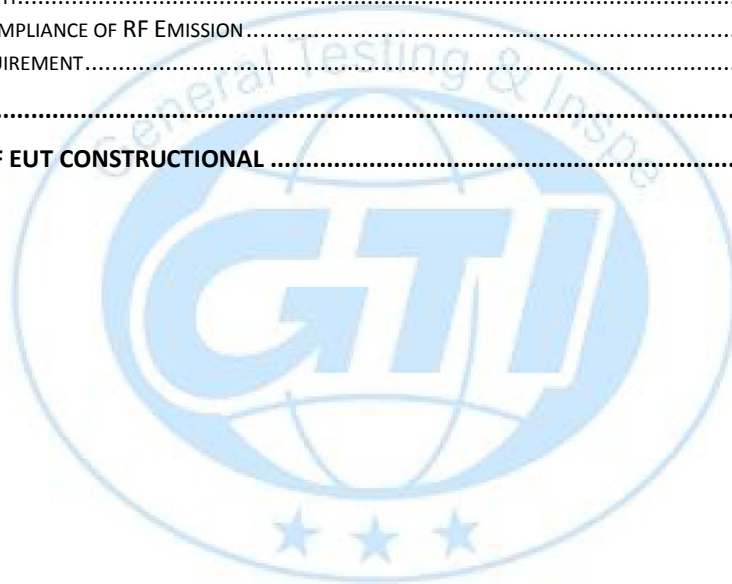

# 1. SUMMARY

## 1.1. Test Standards

The tests were performed according to following standards:

**FCC Rules Part 15.247:** Frequency Hopping, Direct Spread Spectrum and Hybrid Systems that are in operation within the bands of 902-928 MHz, 2400-2483.5 MHz, and 5725-5850 MHz

**ANSI C63.10-2013:** American National Standard for Testing Unlicensed Wireless Devices

**558074 D01 DTS Meas Guidance v01:** Guidance for Performing Compliance Measurements on Digital Transmission Systems (DTS) Operating Under §15.247

## 1.2. Test Description

FCC PART 15.247		
FCC Part 15.207	AC Power Conducted Emission	PASS
FCC Part 15.247(a)(2)	6dB Bandwidth	PASS
FCC Part 15.247(d)	Spurious RF Conducted Emission	N/A
FCC Part 15.247(b)	Maximum Peak Output Power	PASS
FCC Part 15.247(e)	Power Spectral Density	PASS
FCC Part 15.205/ 15.209	Radiated Emissions	PASS
FCC Part 15.247(d)	Band Edge	PASS
FCC Part 15.203/15.247 (b)	Antenna Requirement	PASS

.Note 1:EUT is battery power supply. conducted emission is not need

### 1.3. Test Facility

#### 1.3.1 Address of the test laboratory

**Shenzhen General Testing & Inspection Technology Co., Ltd.**

Add: 1-2/F., Building 2, Jiaquan Building, Guanlan High-Tech Park, Shenzhen, Guangdong, China

#### 1.3.2 Laboratory accreditation

The test facility is recognized, certified, or accredited by the following organizations:

##### IC Registration No.: 9783A

The 3m alternate test site of Shenzhen GTI Technology Co., Ltd. EMC Laboratory has been registered by Certification and Engineer Bureau of Industry Canada for the performance of with Registration NO.: 9783A on Jan, 2016.

##### FCC-Registration No.: 951311

Shenzhen GTI Technology Co., Ltd. EMC Laboratory has been registered and fully described in a report filed with the (FCC) Federal Communications Commission. The acceptance letter from the FCC is maintained in our files. Registration 951311, Aug 26, 2017

### 1.4. Measurement Uncertainty

The data and results referenced in this document are true and accurate. The reader is cautioned that there may be errors within the calibration limits of the equipment and facilities. The measurement uncertainty was calculated for all measurements listed in this test report acc. to CISPR 16 - 4 Specification for radio disturbance and immunity measuring apparatus and methods – Part 4: Uncertainty in EMC Measurements and is documented in the Shenzhen General Testing & Inspection Technology Co., Ltd quality system acc. to DIN EN ISO/IEC 17025. Furthermore, component and process variability of devices similar to that tested may result in additional deviation. The manufacturer has the sole responsibility of continued compliance of the device.

Hereafter the best measurement capability for General Testing & Inspection laboratory is reported:

Test Items	Measurement Uncertainty	Notes
Transmitter power conducted	0.57 dB	(1)
Transmitter power Radiated	2.20 dB	(1)
Conducted spurious emission 9KHz-40 GHz	1.60 dB	(1)
Radiated spurious emission 9KHz-40 GHz	2.20 dB	(1)
Conducted Emission 9KHz-30MHz	3.39 dB	(1)
Radiated Emission 30~1000MHz	4.24 dB	(1)
Radiated Emission 1~18GHz	5.16 dB	(1)
Radiated Emission 18-40GHz	5.54 dB	(1)
Occupied Bandwidth	-----	(1)

(1) This uncertainty represents an expanded uncertainty expressed at approximately the 95% confidence level using a coverage factor of k=1.96.

## 2. GENERAL INFORMATION

### 2.1.Environmental conditions

During the measurement the environmental conditions were within the listed ranges:

Temperature:	15~35°C
Relative Humidity:	30~75 %
Air Pressure:	950~1050mba

### 2.2.General Description of EUT

Product Name:	Smart TV Box
Model/Type reference:	SS-1000
Power supply:	Adapter: Input:100-240V AC, 50/60 Hz 0.7A MAX Output: 5VDC 2A
Hardware version:	V1.1
Software version:	ATN-3.0.0 2017-03-18.134627
<b>WIFI :</b>	
Supported type:	802.11b/802.11g/802.11n(H20)/ 802.11n(H40)
Modulation:	802.11b: DSSS 802.11g/802.11n(H20)/ 802.11n(H40): OFDM
Operation frequency:	802.11b/802.11g/802.11n(H20)/ 802.11n(H20)/ 802.11n(H40): 2412MHz~2462MHz
Channel number:	802.11b/802.11g/802.11n(H20): 11; 802.11n(H40): 7
Channel separation:	5MHz
Antenna type:	External Antenna
Antenna gain:	3dBi

Note: For a more detailed features description, please refer to the manufacturer's specifications or the User's Manual.

## 2.3. Description of Test Modes

### Peripherals Devices:

OUTSIDE SUPPORT EQUIPMENT						
No.	Equipment	Model	Serial No.	Manufacture	Trade name	Remark
1	Adapter	HJ-AD18-0 50200	/	/	/	/
2	LCD Colour TV	LCD-32NX3 30A	10992742 9	SHARP	/	/

**Note:** All the above equipment /cable were placed in worse case position to maximize emission signals during emission test.

### Operation Frequency

The Applicant provides communication tools software to control the EUT for staying in continuous transmitting (Duty Cycle more than 98%) mode for testing.

### WIFI

Channel	Frequency (MHz)
<b>00</b>	<b>2412</b>
02	2417
<b>03</b>	<b>2422</b>
04	2427
<b>06</b>	<b>2437</b>
07	2442
08	2447
<b>09</b>	<b>2452</b>
10	2457
<b>11</b>	<b>2462</b>

## 2.1.Measurement Instruments List

Maximum Conducted Output Power					
Item	Test Equipment	Manufacturer	Model No.	Serial No.	Calibrated until
1	Power Meter	Anritsu	ML2487B	110553	Jan. 05,2019
2	Power Sensor	Anritsu	MA2411B	100345	Jan. 05,2019
3	Spectrum Analyzer	R&S	FSU26	100105	Jan. 05,2019

Power Spectral Density / 6dB Bandwidth / Band Edge Compliance of RF Emission / Spurious RF Conducted Emission					
Item	Test Equipment	Manufacturer	Model No.	Serial No.	Calibrated until
1	Spectrum Analyzer	R&S	FSU26	100105	Jan. 05,2019

Conducted Emission					
Item	Test Equipment	Manufacturer	Model No.	Serial No.	Calibrate until
1	LISN	R&S	ENV216	101112	Jan. 05,2019
2	LISN	R&S	ENV216	101113	Jan. 05,2019
3	EMI Test Receiver	R&S	ESCI	100920	Jan. 05,2019
4	Cable	Schwarzbeck	AK9515E	33156	Jan. 05,2019

Radiated Emission					
Item	Test Equipment	Manufacturer	Model No.	Serial No.	Calibrated until
1	EMI Test Receiver	R&S	ESCI	100658	Jan. 05,2019
2	High pass filter	micro-tranics	HPM50111	34202	Jan. 05,2019
3	Log-Bicon Antenna	Schwarzbeck	CBL6141A	4180	Jan. 05,2019
4	Ultra-Broadband Antenna	ShwarzBeck	BBHA9170	25841	Jan. 05,2019
5	Loop Antenna	LAPLAC	RF300	9138	Jan. 05,2019
6	Spectrum Analyzer	Rohde & Schwarz	FSU	100105	Jan. 05,2019
7	Horn Antenna	Schwarzbeck	BBHA 9120D	647	Jan. 05,2019
8	Pre-Amplifier	HP	8447D	1937A03050	Jan. 05,2019
9	Pre-Amplifier	EMCI	EMC05183 5	980075	Jan. 05,2019
10	Antenna Mast	UC	UC3000	N/A	N/A
11	Turn Table	UC	UC3000	N/A	N/A
12	Cable Below 1GHz	Schwarzbeck	AK9515E	33155	Jan. 05,2019
13	Cable Above 1GHz	Hubersuhner	SUCOFLEX1 02	DA1580	Jan. 05,2019

Note: 1. The Cal.Interval was one year.

2. The cable loss has calculated in test result which connection between each test instruments.



### 3. TEST CONDITIONS AND RESULTS

#### 3.1. CONDUCTED EMISSION MEASUREMENT

##### Limit

POWER LINE CONDUCTED EMISSION

(Frequency Range 150KHz-30MHz)

FREQUENCY (MHz)	Limit	
	Quasi-peak	Average
0.15 -0.5	66 - 56 *	56 - 46 *
0.50 -5.0	56.00	46.00
5.0 -30.0	60.00	50.00

Note:

(1) The tighter limit applies at the band edges.

(2) The limit of " \* " marked band means the limitation decreases linearly with the logarithm of the frequency in the range.

The following table is the setting of the receiver

Receiver Parameters	Setting
Attenuation	10 dB
Start Frequency	0.15 MHz
Stop Frequency	30 MHz
IF Bandwidth	9 kHz

##### Test Procedure

1. The EUT was placed 0.8 meters from the horizontal ground plane with EUT being connected to the power mains through a line impedance stabilization network (LISN). All other support equipments powered from additional LISN(s). The LISN provide 50 Ohm/ 50uH of coupling impedance for the measuring instrument.
2. Interconnecting cables that hang closer than 40 cm to the ground plane shall be folded back and forth in the center forming a bundle 30 to 40 cm long.
3. I/O cables that are not connected to a peripheral shall be bundled in the center. The end of the cable may be terminated, if required, using the correct terminating impedance. The overall length shall not exceed 1 m. Repeat above procedures until all frequency measurements have been completed.
4. LISN at least 80 cm from nearest part of EUT chassis.
5. For the actual test configuration, please refer to the related Item –EUT Test Photos.

##### Test Configuration

For the actual test configuration, please refer to the related Item –EUT Test Photos.

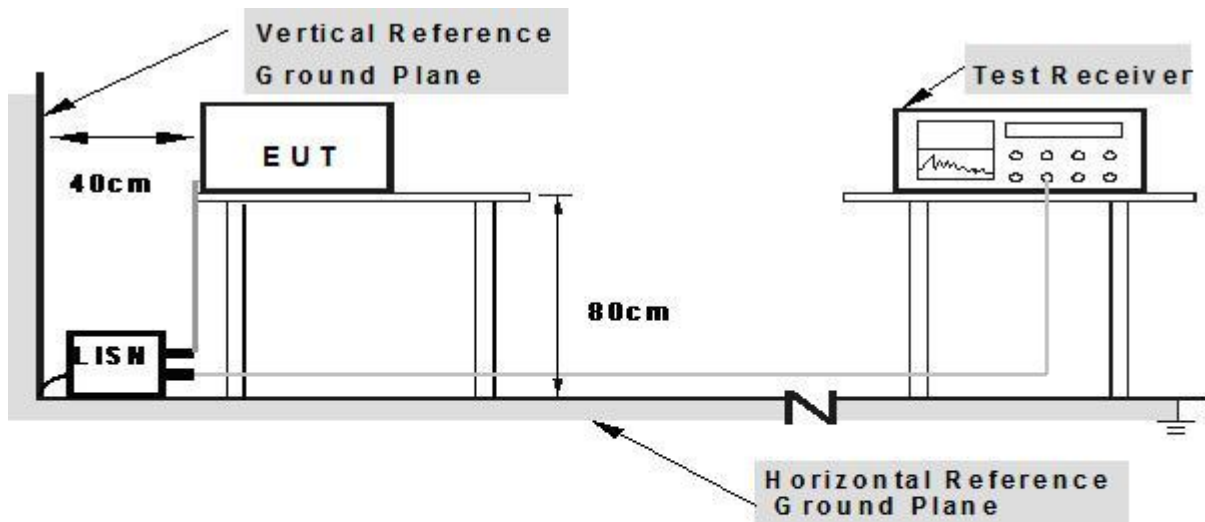

**Note: 1.Support units were connected to second LISN.**

**2.Both of LISNs (AMN) are 80 cm from EUT and at least 80 cm from other units and other metal planes**



**Test Results**

**TEST RESULTS**

Temperature :	23.5 °C	Relative Humidity :	60%
Pressure :	101 Kpa	Test Date :	2017-12-26
Test Mode :	802.11 b TX mode	Phase :	L
Test Voltage :	AC 120V/60Hz		

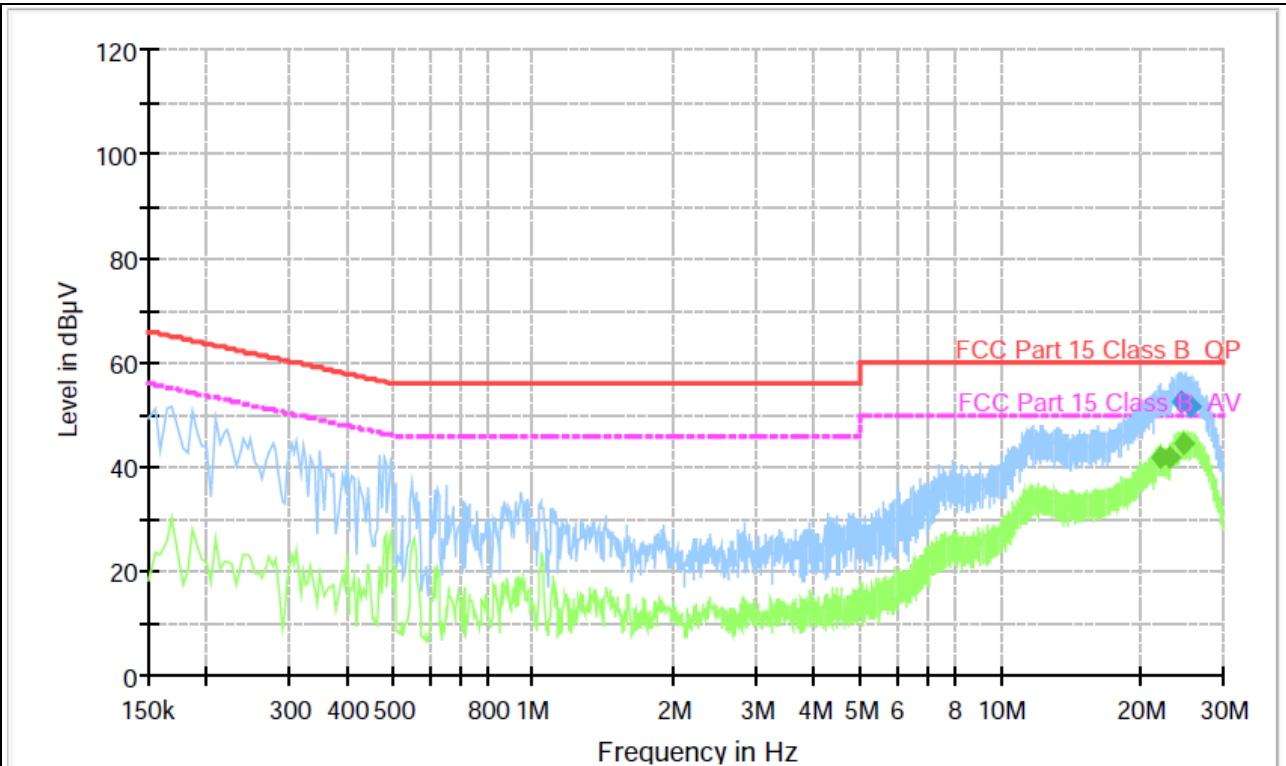

**Final Measurement Detector 1**

Frequency (MHz)	QuasiPeak (dBµV)	Meas. Time (ms)	Bandwidth (kHz)	Filter	Line	Corr. (dB)	Margin (dB)	Limit (dBµV)	Comment
24.337500	52.4	1000.000	9.000	Off	L1	10.0	7.6	60.0	
24.571500	52.5	1000.000	9.000	Off	L1	10.0	7.5	60.0	
25.615500	51.6	1000.000	9.000	Off	L1	10.1	8.4	60.0	

**Final Measurement Detector 2**

Frequency (MHz)	Average (dBµV)	Meas. Time (ms)	Bandwidth (kHz)	Filter	Line	Corr. (dB)	Margin (dB)	Limit (dBµV)	Comment
22.119000	41.7	1000.000	9.000	Off	L1	10.0	8.3	50.0	
23.023500	41.8	1000.000	9.000	Off	L1	10.0	8.2	50.0	
24.693000	44.7	1000.000	9.000	Off	L1	10.0	5.3	50.0	

LINE	N
------	---

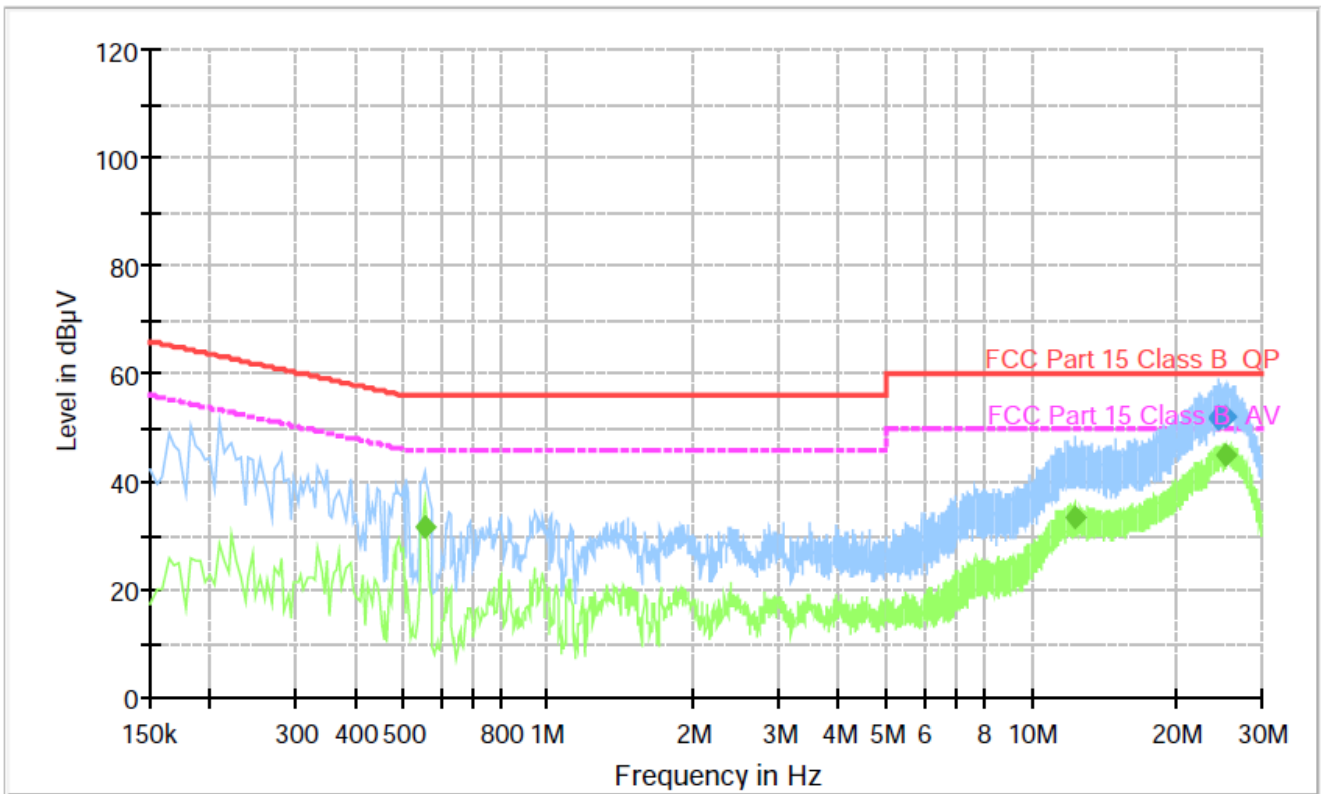

### Final Measurement Detector 1

Frequency (MHz)	QuasiPeak (dBµV)	Meas. Time (ms)	Bandwidth (kHz)	Filter	Line	Corr. (dB)	Margin (dB)	Limit (dBµV)	Comment
24.396000	51.7	1000.000	9.000	Off	N	10.1	8.3	60.0	
24.513000	51.9	1000.000	9.000	Off	N	10.1	8.1	60.0	
25.431000	51.9	1000.000	9.000	Off	N	10.2	8.1	60.0	

### Final Measurement Detector 2

Frequency (MHz)	Average (dBµV)	Meas. Time (ms)	Bandwidth (kHz)	Filter	Line	Corr. (dB)	Margin (dB)	Limit (dBµV)	Comment
0.555000	31.7	1000.000	9.000	Off	N	10.1	14.3	46.0	
12.268500	33.2	1000.000	9.000	Off	N	9.7	16.8	50.0	
25.206000	44.8	1000.000	9.000	Off	N	10.2	5.2	50.0	

Temperature :	23.5 °C	Relative Humidity :	60%
Pressure :	101 Kpa	Test Date :	2017-12-26
Test Mode :	802.11 b TX mode	Phase :	L
Test Voltage :	AC 230V/60Hz		

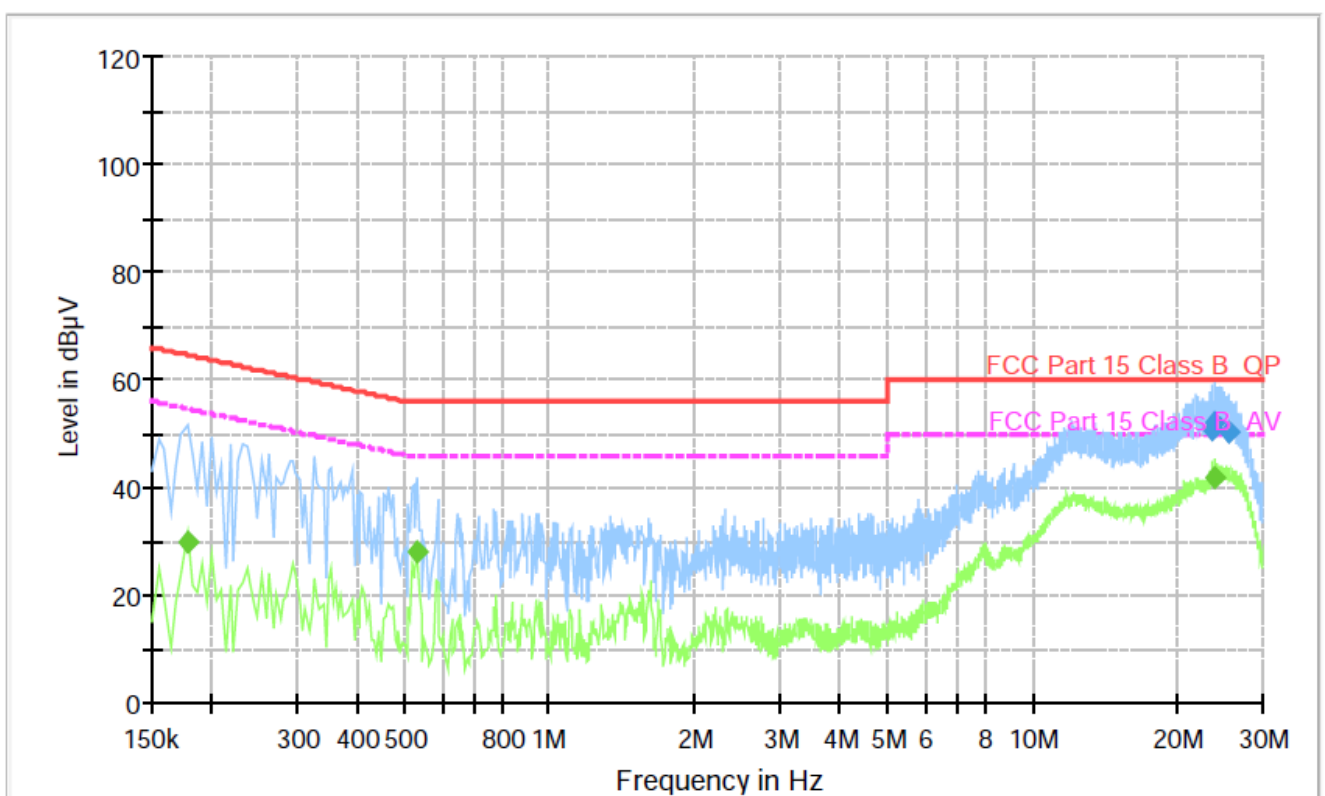

### Final Measurement Detector 1

Frequency (MHz)	QuasiPeak (dBµV)	Meas. Time (ms)	Bandwidth (kHz)	Filter	Line	Corr. (dB)	Margin (dB)	Limit (dBµV)	Comment
23.514000	50.8	1000.000	9.000	Off	L1	10.0	9.2	60.0	
23.977500	52.1	1000.000	9.000	Off	L1	10.0	7.9	60.0	
25.678500	50.1	1000.000	9.000	Off	L1	10.1	9.9	60.0	

### Final Measurement Detector 2

Frequency (MHz)	Average (dBµV)	Meas. Time (ms)	Bandwidth (kHz)	Filter	Line	Corr. (dB)	Margin (dB)	Limit (dBµV)	Comment
0.177000	30.0	1000.000	9.000	Off	L1	10.0	24.6	54.6	
0.532500	28.0	1000.000	9.000	Off	L1	9.8	18.0	46.0	
23.770500	41.6	1000.000	9.000	Off	L1	10.0	8.4	50.0	

LINE	N
------	---

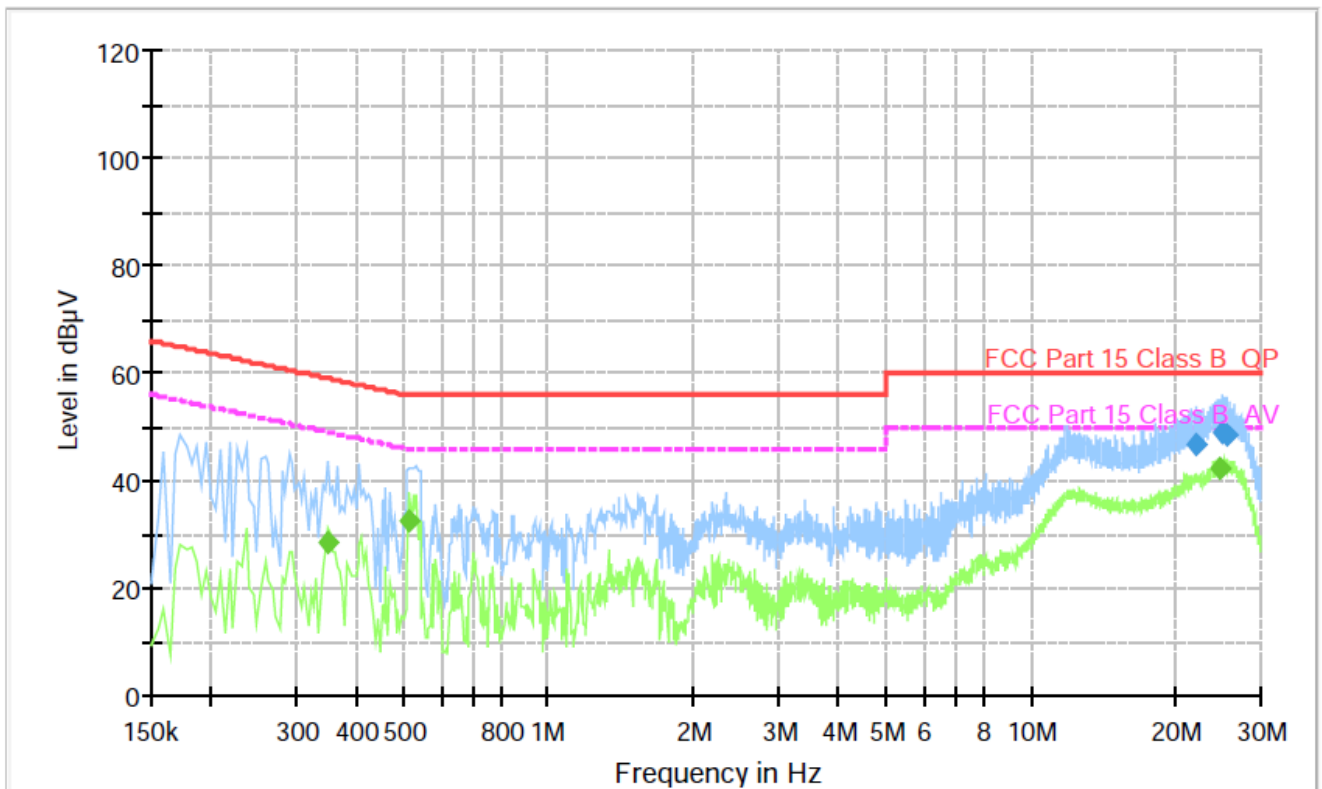

### Final Measurement Detector 1

Frequency (MHz)	QuasiPeak (dBµV)	Meas. Time (ms)	Bandwidth (kHz)	Filter	Line	Corr. (dB)	Margin (dB)	Limit (dBµV)	Comment
22.155000	46.5	1000.000	9.000	Off	N	10.0	13.5	60.0	
25.003500	48.7	1000.000	9.000	Off	N	10.2	11.3	60.0	
25.674000	48.4	1000.000	9.000	Off	N	10.2	11.6	60.0	

### Final Measurement Detector 2

Frequency (MHz)	Average (dBµV)	Meas. Time (ms)	Bandwidth (kHz)	Filter	Line	Corr. (dB)	Margin (dB)	Limit (dBµV)	Comment
0.348000	28.6	1000.000	9.000	Off	N	9.9	20.4	49.0	
0.514500	32.4	1000.000	9.000	Off	N	10.1	13.6	46.0	
24.657000	42.4	1000.000	9.000	Off	N	10.1	7.6	50.0	

### 3.2. Radiated Emission

#### Limit

For intentional device, according to § 15.209(a), the general requirement of field strength of radiated emission from intentional radiators at a distance of 3 meters shall not exceed the following table. According to § 15.247(d), in any 100kHz bandwidth outside the frequency band in which the EUT is operating, the radio frequency power that is produced by the intentional radiator shall be at least 20dB below that in the 100kHz bandwidth within the band that contains the highest level of desired power.

The frequency spectrum above 1 GHz for Transmitter was investigated. All emission not reported are much lower than the prescribed limits. Set the RBW=1MHz, VBW=3MHz for Peak Detector while the RBW=1MHz, VBW=10Hz for Average Detector, Readings are both peak and average values. The pre-test have done for the EUT in three axes and found the worst emission at position shown in test setup photos.

Frequency (MHz)	Distance (Meters)	Radiated (dBuV/m)	Radiated (µV/m)
0.009-0.49	3	$20\log(2400/F(KHz))+40\log(300/3)$	$2400/F(KHz)$
0.49-1.705	3	$20\log(24000/F(KHz))+40\log(30/3)$	$24000/F(KHz)$
1.705-30	3	$20\log(30)+40\log(30/3)$	30
30-88	3	40.0	100
88-216	3	43.5	150
216-960	3	46.0	200
Above 960	3	54.0	500

#### Test Procedure

- The EUT was placed on a turn table which is 0.8m above ground plane..
- Maximum procedure was performed by raising the receiving antenna from 1m to 4m and rotating the turn table from 0°C to 360°C to acquire the highest emissions from EUT
- And also, each emission was to be maximized by changing the polarization of receiving antenna both horizontal and vertical.
- Repeat above procedures until all frequency measurements have been completed.

#### Field Strength Calculation

The field strength is calculated by adding the Antenna Factor and Cable Factor and subtracting the Amplifier Gain and Duty Cycle Correction Factor (if any) from the measured reading. The basic equation with a sample calculation is as follows:

$$FS = RA + AF + CL - AG$$

Where	FS = Field Strength	CL = Cable Attenuation Factor (Cable Loss)
	RA = Reading Amplitude	AG = Amplifier Gain
	AF = Antenna Factor	

For example

Frequency (MHz)	FS (dBµV/m)	RA (dBµV/m)	AF (dB)	CL (dB)	AG (dB)	Transd (dB)
150.00	40	58.1	12.2	1.6	31.90	-18.1

Transd=AF +CL-AG

**Test Configuration**

For the actual test configuration, please refer to the related Item –EUT Test Photos.

**Frequency range 9 KHz – 30MHz**

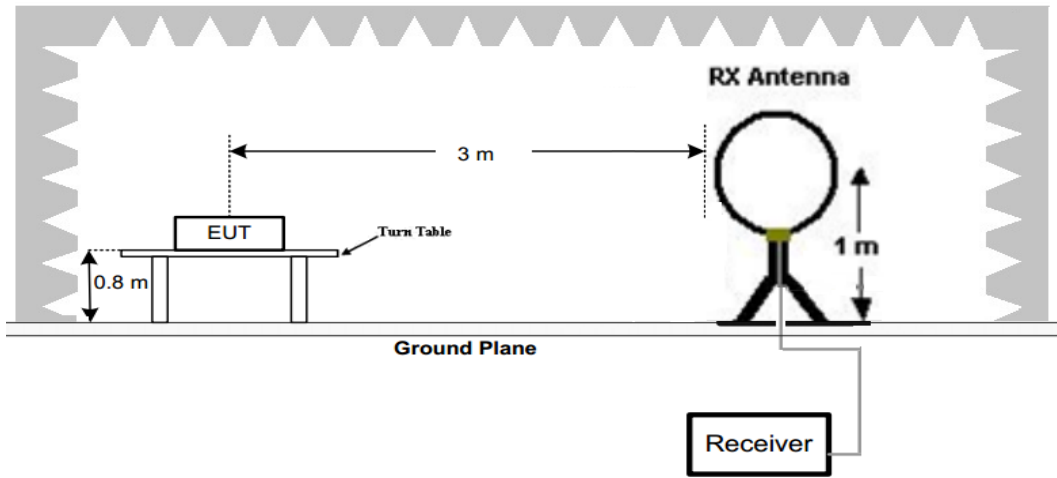

**Frequency range 30MHz – 1000MHz**

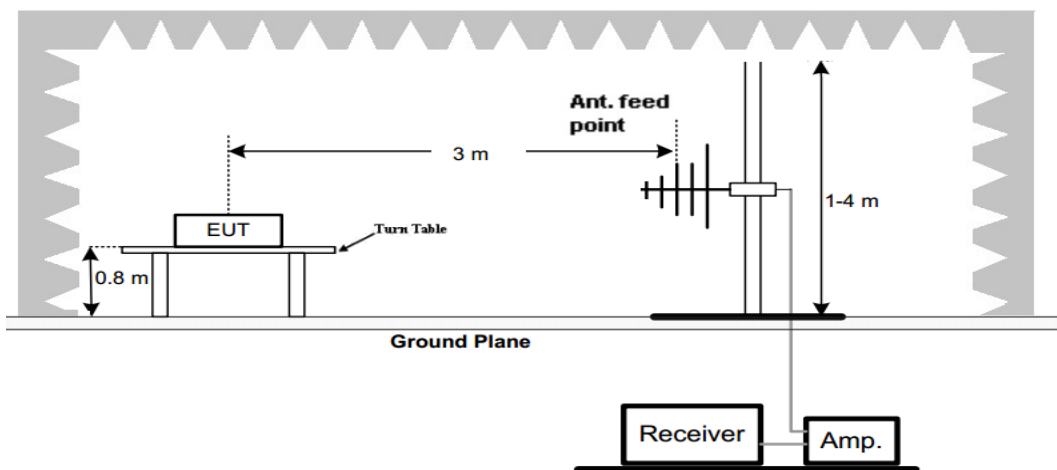

**Frequency range above 1GHz-25GHz**

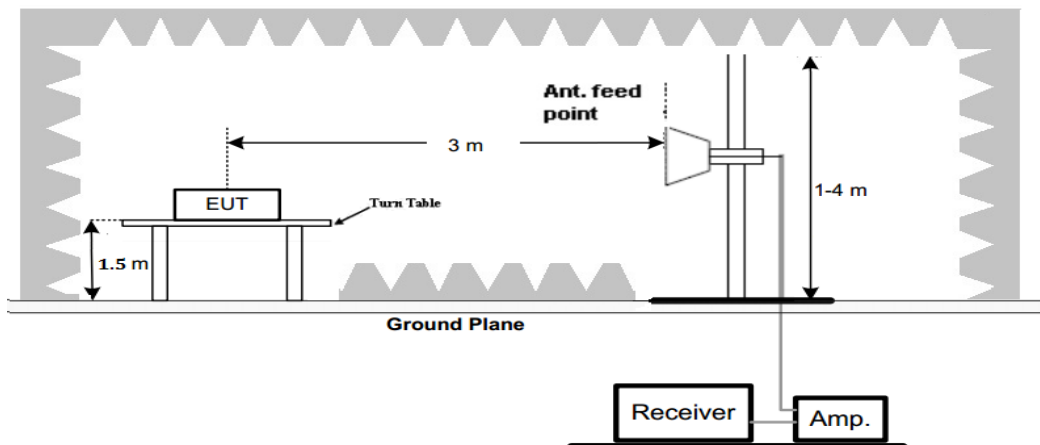



**Test Results**

Remark:

1. We tested three channels for each mode and recorded worst case at low channel of WIFI mode from 30MHz to 1GHz.

**For 9 KHz-30MHz**

The test results of 9kHz-30MHz is attenuated more than 20dB below the permissible limits, so the results don't record in the report.

**For 30MHz-1GHz For 802.11b Low Channel**

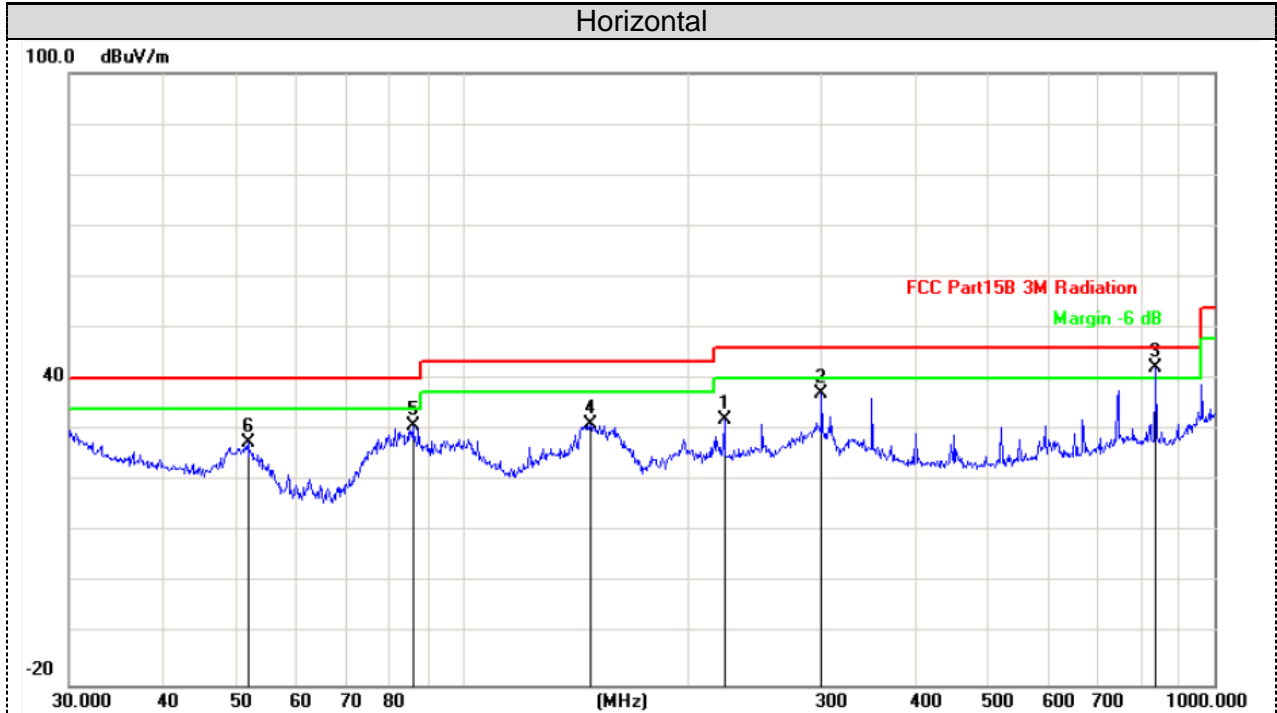

No.	Frequency (MHz)	Factor (dB/m)	Reading (dBuV)	Level (dBuV/m)	Limit (dBuV/m)	Margin (dB)	Detector	Height (cm)	Azimuth ( )	P/F	Remark
1	222.9502	-12.92	44.83	31.91	46.00	-14.09	QP			P	
2	300.3672	-11.73	49.01	37.28	46.00	-8.72	QP			P	
3	836.2443	-4.03	46.43	42.40	46.00	-3.60	QP			P	
4	147.9214	-15.88	46.98	31.10	43.50	-12.40	QP			P	
5	85.8983	-17.03	47.76	30.73	40.00	-9.27	QP			P	
6	51.8430	-12.36	39.84	27.48	40.00	-12.52	QP			P	

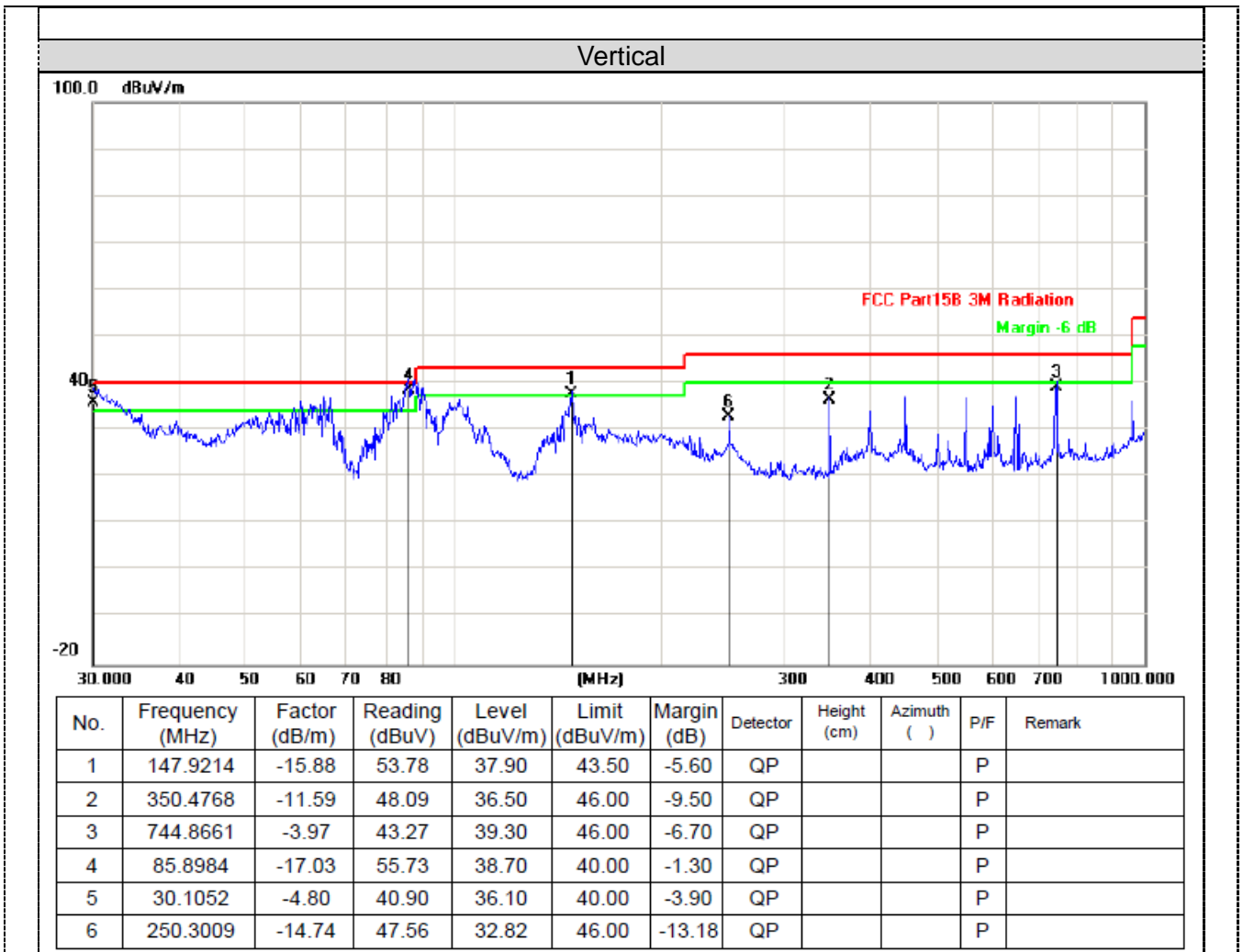

REMARKS:

1. Emission level (dBuV/m) = Raw Value (dBuV) + Correction Factor (dB/m)
2. Correction Factor (dB/m) = Antenna Factor (dB/m) + Cable Factor (dB) - Pre-amplifier Factor
3. Margin value = Limit value - Emission level.
4. -- Mean the PK detector measured value is below average limit.
5. The other emission levels were very low against the limit.

**Above 1GHz emission please refer to C180125Z01-S report**

### 3.3. Maximum Conducted Output Power

#### Limit

30dBm for digital modulation systems.

#### Test Procedure

- maximum (average) conducted output power - Measurement using a RF average power meter
  1. Remove the antenna from the EUT and then connect a low loss RF cable from the antenna port to the Power Meter.
  2. Ensure EUT transmitting with a duty cycle  $\geq 98\%$ .
  3. Record the value of Power Meter.
- Maximum peak conducted output power
  1. Set the RBW  $\geq$  DTS bandwidth
  2. Set VBW  $\geq 3 \times$  RBW.
  3. Set span  $\geq 3 \times$  RBW
  4. Sweep time = auto couple.
  5. Detector = peak.
  6. Trace mode = max hold.
  7. Allow trace to fully stabilize.
  8. Use peak marker function to determine the peak amplitude level

Note: WIFI: Use the maximum (average) conducted output power test procedure  
BT4.0: Use the maximum peak conducted output power test procedure

#### Test Configuration

- For Maximum conducted (average) output power



- For Maximum peak conducted output power

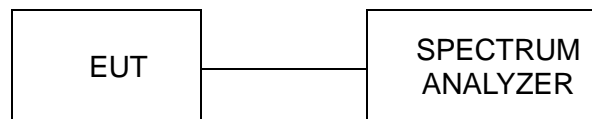

**Test Results**

WIFI				
Type	Channel	Output power AV(dBm)	Limit (dBm)	Result
802.11b	01	13.39	30.00	Pass
	06	12.32		
	11	12.81		
802.11g	01	12.51	30.00	Pass
	06	12.29		
	11	11.49		
802.11n(H20)	01	11.13	30.00	Pass
	06	11.78		
	11	12.03		
802.11n(H40)	03	15.28	30.00	Pass
	06	14.96		
	09	14.53		

Note: The test results including the cable loss.

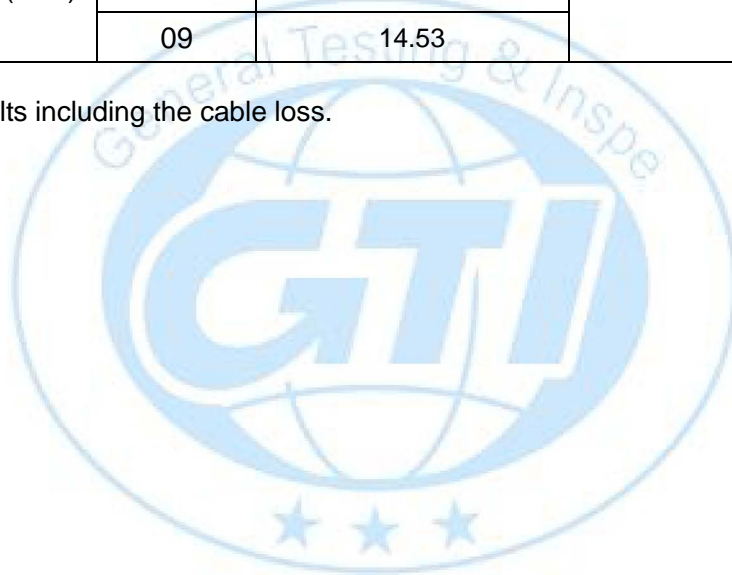

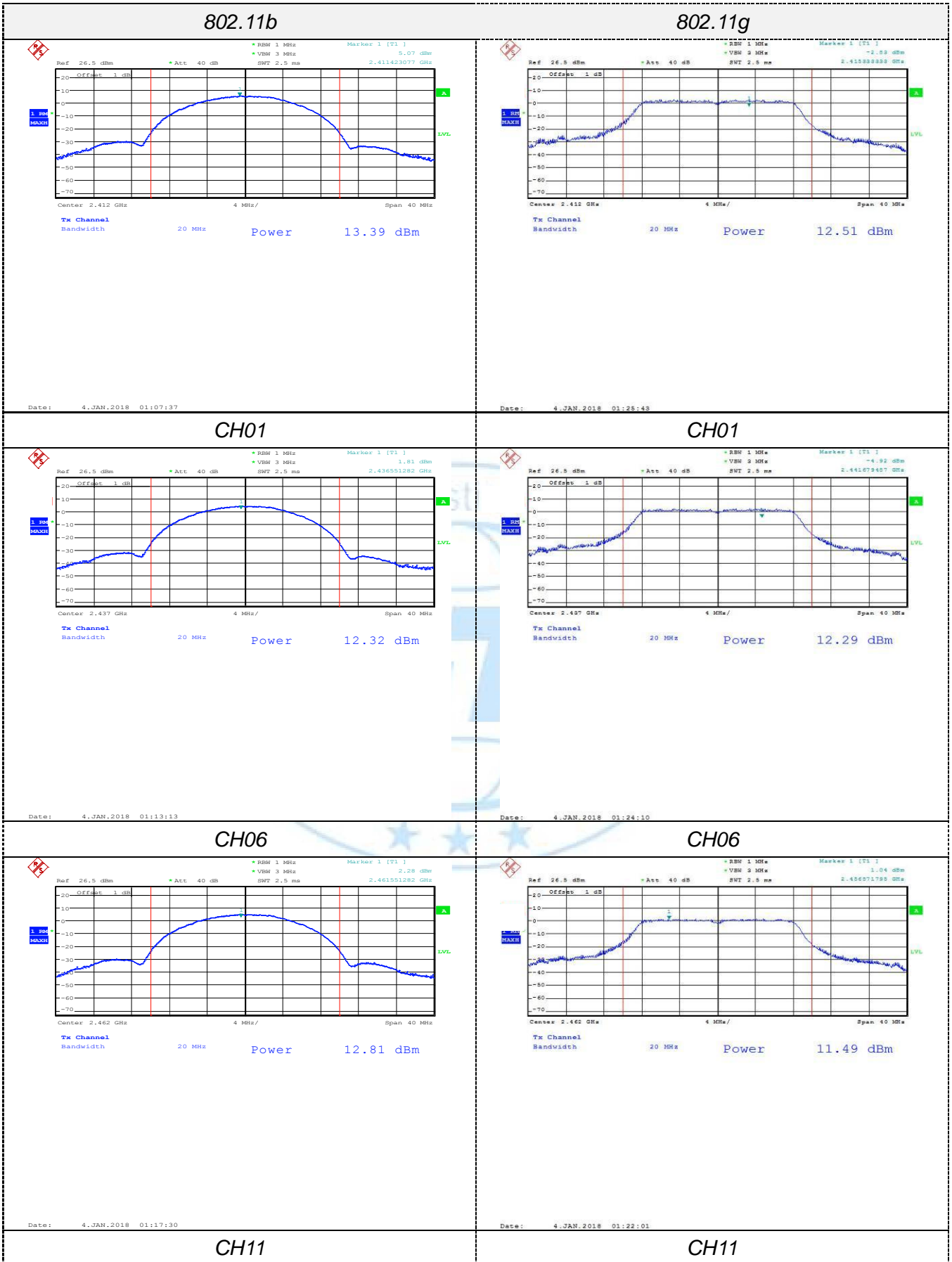

Shenzhen General Testing & Inspection Technology Co., Ltd.

1-2/F., Building 2, Jiaquan Building, Guanlan High-Tech Park, Shenzhen, Guangdong, China  
 Tel.: (86)755-27521059 Fax: (86)755-27521011 Http://www.sz-ctc.org.cn



For anti-fake verification, please visit the official website of Certification and Accreditation Administration of the People's Republic of China : [yz.cncaic.cn](http://yz.cncaic.cn)

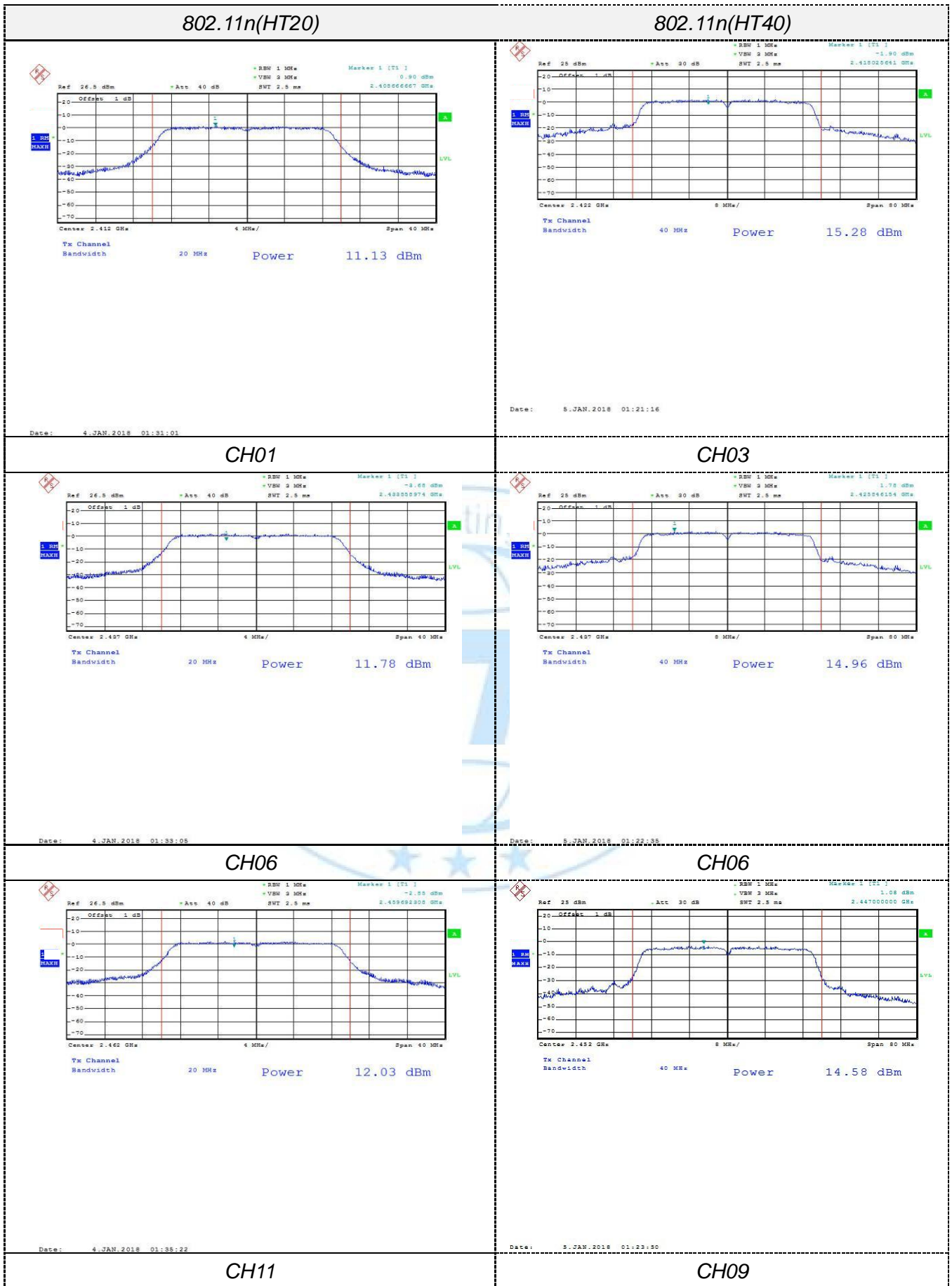

### 3.4. Power Spectral Density

#### Limit

For digitally modulated systems, the power spectral density conducted from the intentional radiator to the antenna shall not be greater than 8 dBm in any 3 kHz band during any time interval of continuous transmission.

#### Test Procedure

1. Use this procedure when the maximum (average) conducted output power was used to demonstrate compliance to the output power limit.
  - a) Set analyzer center frequency to DTS channel center frequency.
  - b) Set span to at least 1.5 times the OBW
  - c) RBW:  $3 \text{ kHz} \leq \text{RBW} \leq 100 \text{ kHz}$ .
  - d) VBW:  $\geq 3 \times \text{RBW}$ .
  - e) Detector: power averaging (RMS)
  - f) Sweep time: Auto couple.
  - g) Swoop points:  $\geq 2 \times \text{span} / \text{RBW}$ .
  - h) Trace mode = Average (100 traces)
  - i) Use the peak marker function to determine the maximum power level.
  - j) If measured value exceeds limit, reduce RBW (no less than 3 kHz) and repeat.

Note: This test procedure is used for WIFI in this report

2. This procedure shall be used if maximum peak conducted output power was used to demonstrate compliance to the output power limit.
  - a) Set analyzer center frequency to DTS channel center frequency.
  - b) Set the span to 1.5 times the DTS bandwidth.
  - c) Set the RBW to:  $3 \text{ kHz} \leq \text{RBW} \leq 100 \text{ kHz}$ .
  - d) Set the VBW  $\geq 3 \times \text{RBW}$ .
  - e) Detector = peak.
  - f) Sweep time = auto couple.
  - g) Trace mode = max hold.
  - h) Allow trace to fully stabilize.
  - i) Use the peak marker function to determine the maximum amplitude level within the RBW.
  - j) If measured value exceeds limit, reduce RBW (no less than 3 kHz) and repeat

Note: This test procedure is used for WIFI in this report

#### Test Configuration

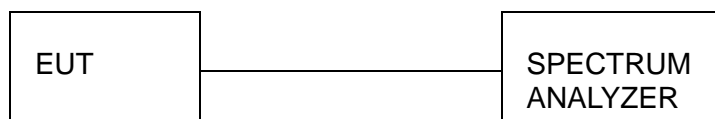

#### Test Results

**WIFI**

Type	Channel	Power Spectral Density (dBm/100KHz)	Limit (dBm/100KHz)	Result
802.11b	01	6.35	8.00	Pass
	06	6.19		
	11	4.90		
802.11g	01	-0.77	8.00	Pass
	06	-0.96		
	11	-1.31		
802.11n(HT20)	01	-1.06	8.00	Pass
	06	-1.55		
	11	-1.71		
802.11n(HT40)	03	-3.93	8.00	Pass
	06	-4.23		
	09	-4.63		

Test plot as follows:





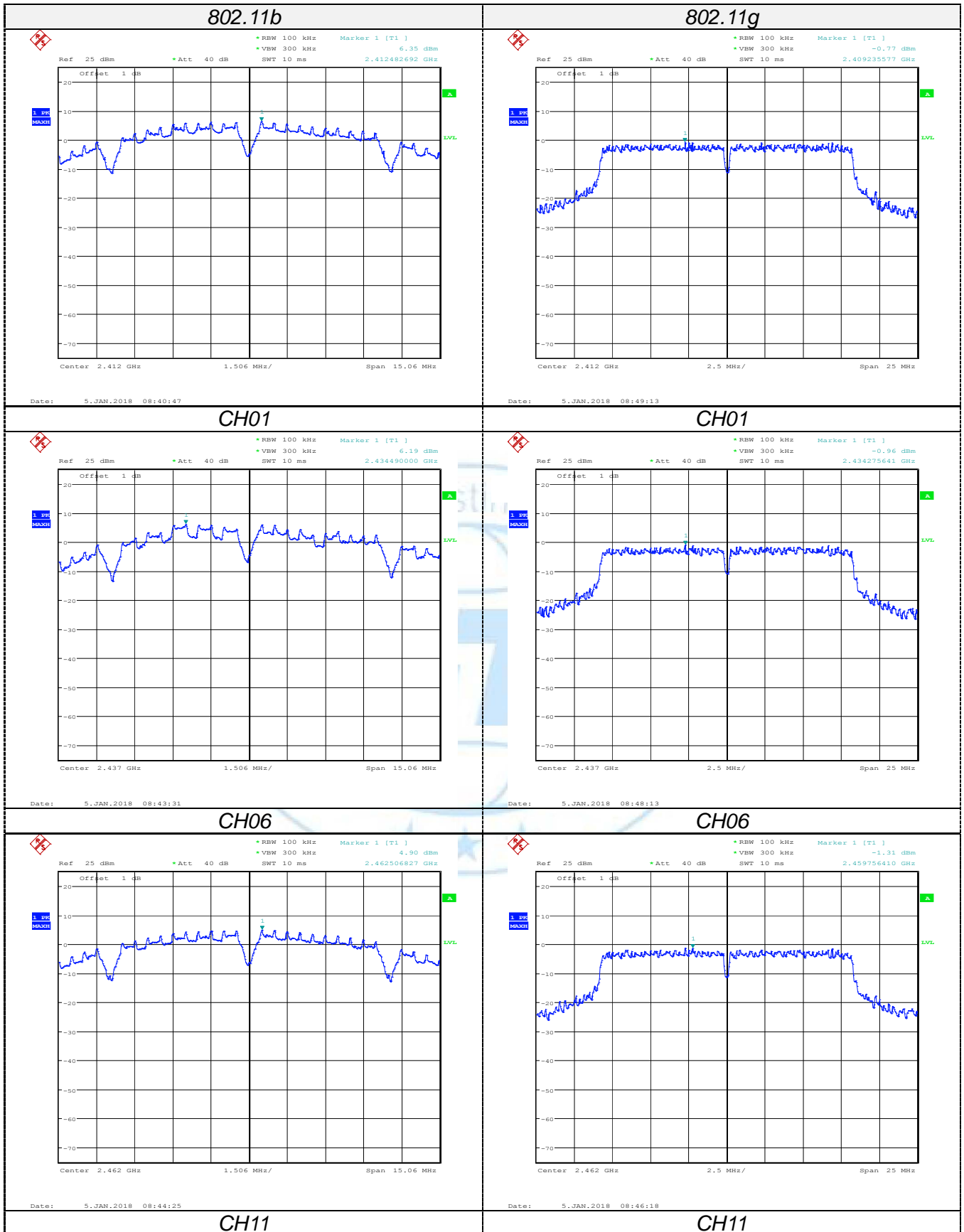

Shenzhen General Testing & Inspection Technology Co., Ltd.

1-2/F., Building 2, Jiaquan Building, Guanlan High-Tech Park, Shenzhen, Guangdong, China  
Tel.: (86)755-27521059 Fax: (86)755-27521011 Http://www.sz-ctc.org.cn



For anti-fake verification, please visit the official website of Certification and Accreditation Administration of the People's Republic of China : [yz.cncaic.cn](http://yz.cncaic.cn)

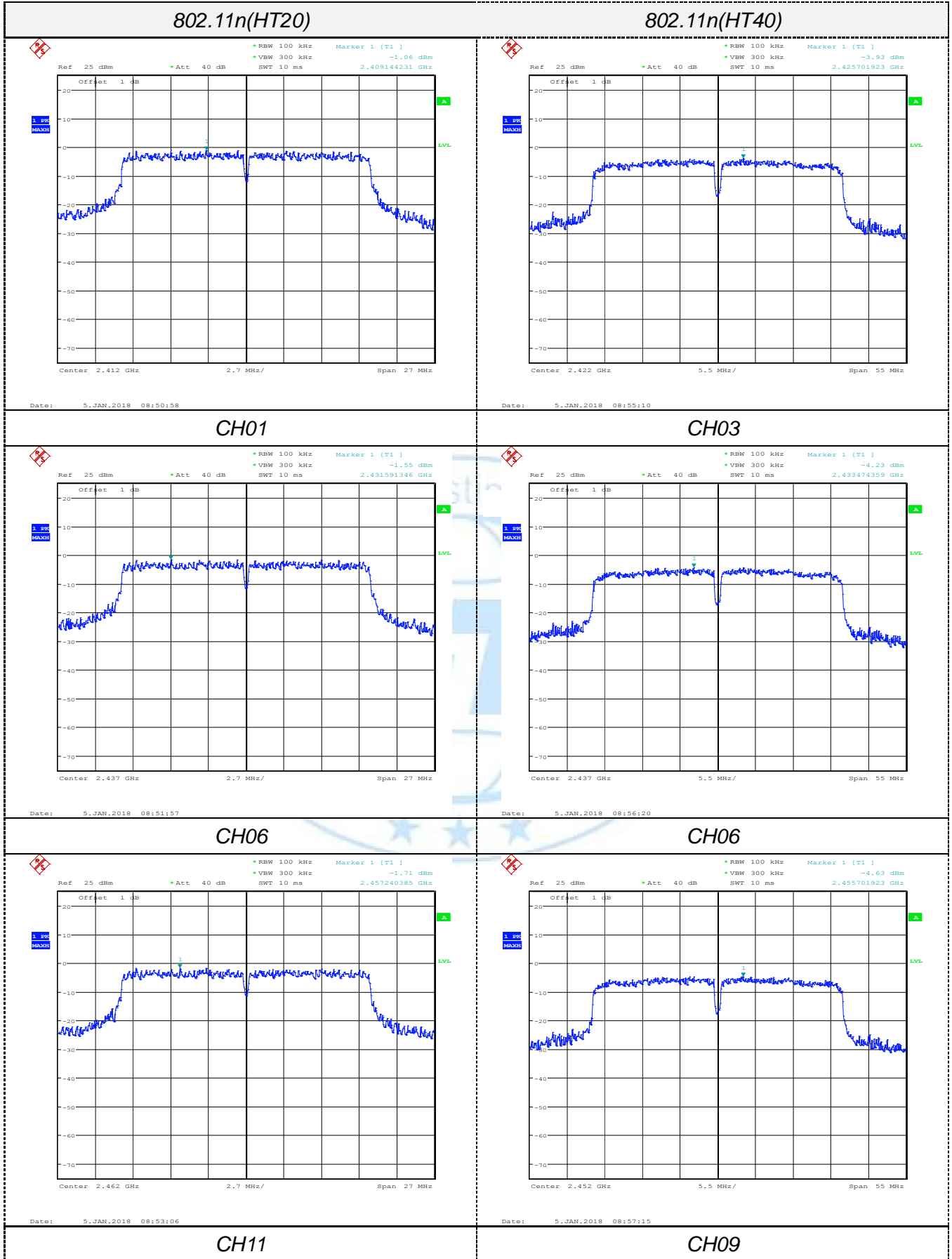

Shenzhen General Testing & Inspection Technology Co., Ltd.

1-2/F., Building 2, Jiaquan Building, Guanlan High-Tech Park, Shenzhen, Guangdong, China

Tel.: (86)755-27521059

Fax: (86)755-27521011

Http://www.sz-ctc.org.cn



For anti-fake verification, please visit the official website of Certification and Accreditation Administration of the People's Republic of China : [yz.cncaic.cn](http://yz.cncaic.cn)

### 3.5.6dB Bandwidth

#### Limit

For digital modulation systems, the minimum 6 dB bandwidth shall be at least 500 kHz

#### Test Procedure

1. The transmitter output was connected to the spectrum analyzer.
2. Set SA as follow:
  - a) RBW: 100 kHz.
  - b) VBW:  $\geq 3 \times$  RBW.
  - c) Detector: Peak.
  - d) Trace mode: max hold.
  - e) Sweep: auto couple.
3. Allow the trace to stabilize.
4. Measure the maximum width of the emission that is constrained by the frequencies associated with the two outermost amplitude points (upper and lower frequencies) that are attenuated by 6 dB relative to the maximum level measured in the fundamental emission.

#### Test Configuration



#### Test Results

WIFI					
Type	Channel	6dB Bandwidth (MHz)	99% OBW (MHz)	Limit (KHz)	Result
802.11b	01	10.064	15.000	≥500	Pass
	06	10.064	15.000		
	11	10.064	17.115		
802.11g	01	16.603	17.820	≥500	Pass
	06	16.603	17.948		
	11	16.603	18.397		
802.11n(HT20)	01	17.821	18.717	≥500	Pass
	06	17.821	18.974		
	11	17.821	17.756		
802.11n(HT40)	03	36.410	36.282	≥500	Pass
	06	36.410	36.538		
	09	36.282	36.410		

Test plot as follows:

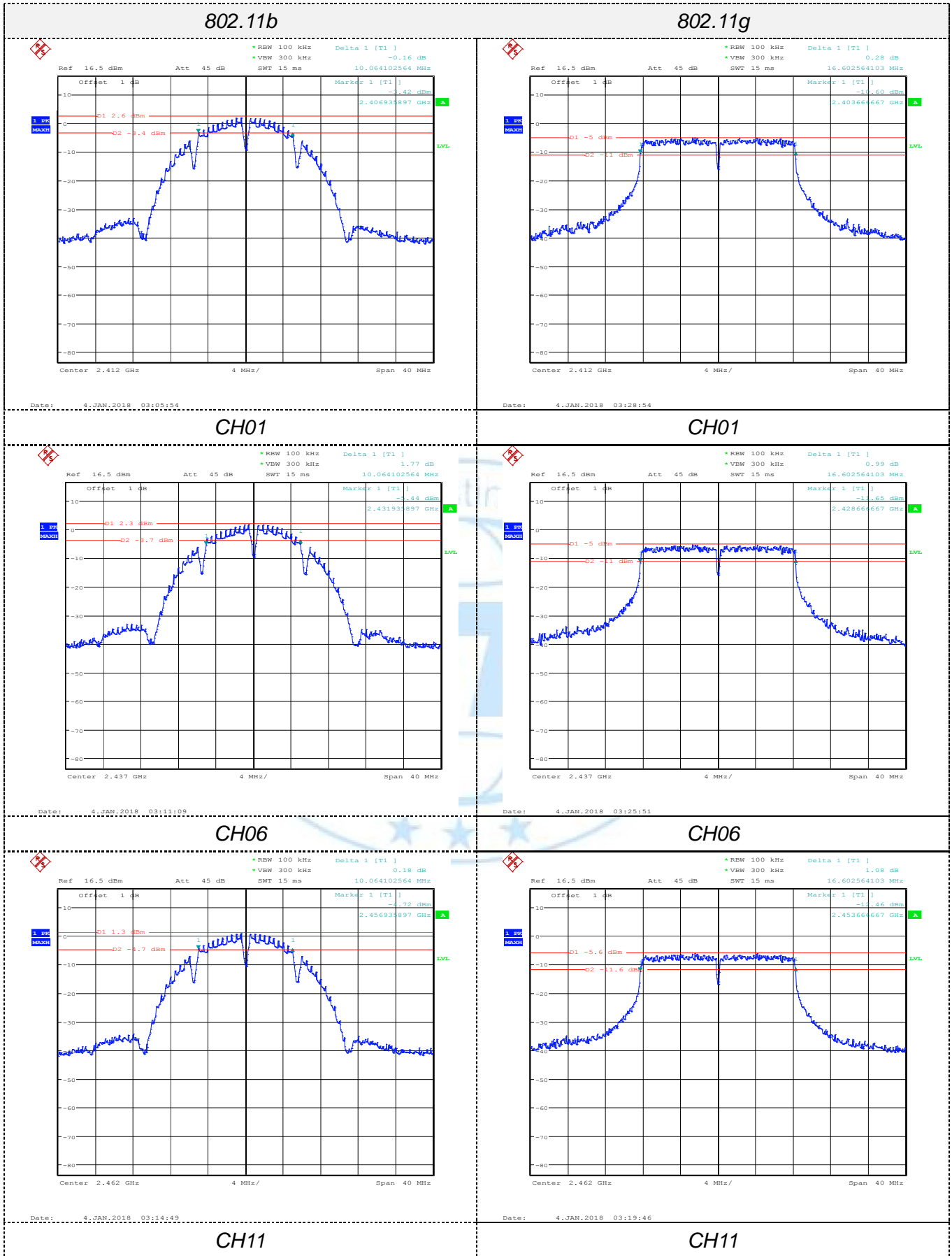

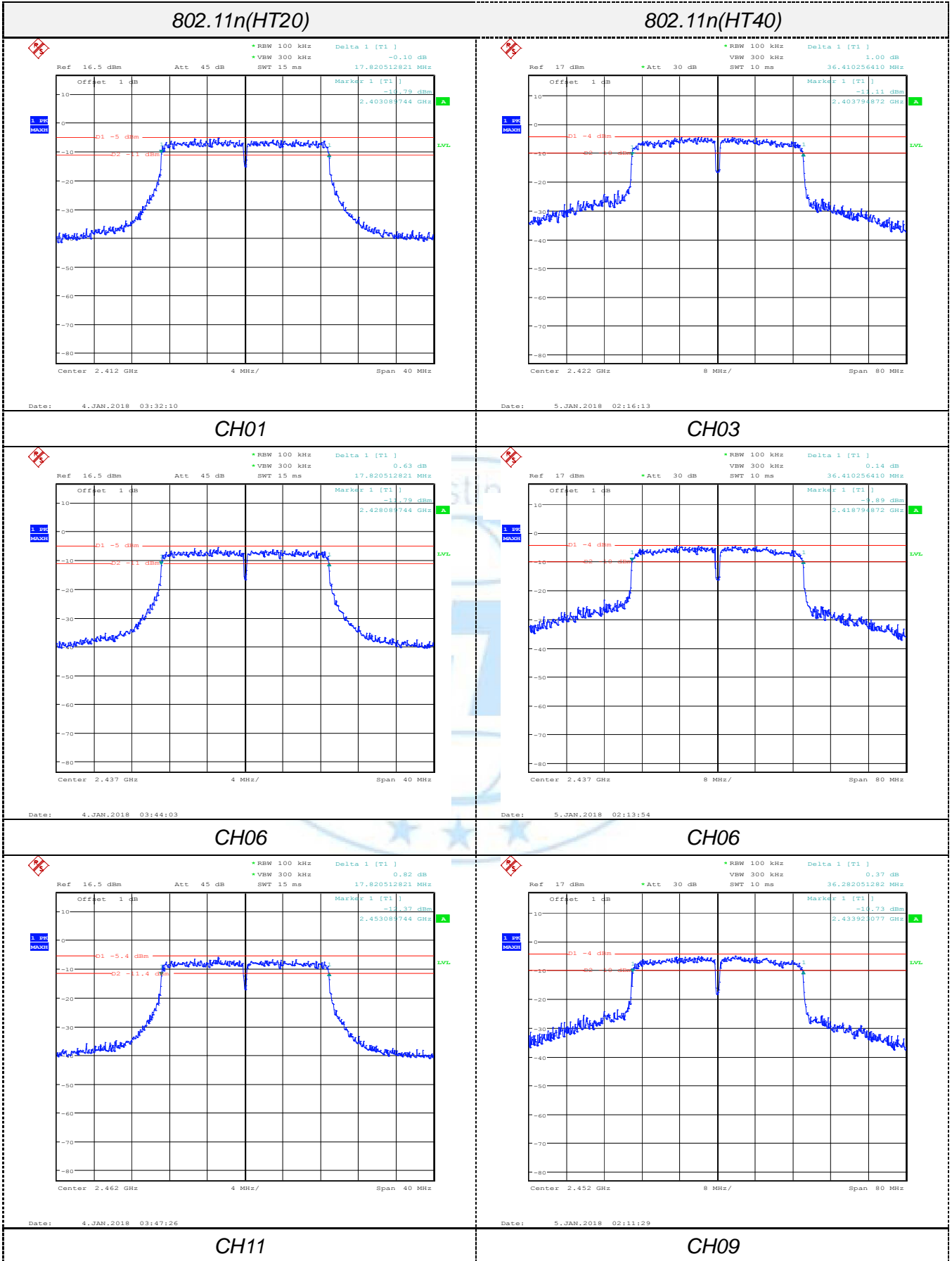

Shenzhen General Testing & Inspection Technology Co., Ltd.

1-2/F., Building 2, Jiaquan Building, Guanlan High-Tech Park, Shenzhen, Guangdong, China  
 Tel.: (86)755-27521059 Fax: (86)755-27521011 Http://www.sz-ctc.org.cn



For anti-fake verification, please visit the official website of Certification and Accreditation Administration of the People's Republic of China : [yz.cncaic.cn](http://yz.cncaic.cn)

### 3.6. Band Edge Compliance of RF Emission

#### Limit

In any 100 kHz bandwidth outside the frequency band in which the spread spectrum or digitally modulated intentional radiator is operating, the radio frequency power that is produced by the intentional radiator shall be at least 20 dB below that in the 100 kHz bandwidth within the band that contains the highest level of the desired power, based on either an RF conducted or a radiated measurement, provided the transmitter demonstrates compliance with the peak conducted power limits. If the transmitter complies with the conducted power limits based on the use of RMS averaging over a time interval, as permitted under paragraph (b)(3) of this section, the attenuation required under this paragraph shall be 30 dB instead of 20 dB. Attenuation below the general limits specified in §15.209(a) is not required. In addition, radiated emissions which fall in the restricted bands, as defined in §15.205(a), must also comply with the radiated emission limits specified in §15.209(a) (see §15.205(c)).

Radiated emissions which fall in the restricted bands, as defined in § 15.205(a), must also comply with the radiated emission limits specified in § 15.209(a)

#### Test Procedure

##### **Test Procedure for conducted method**

- Use this procedure when the maximum (average) conducted output power was used to demonstrate compliance to the output power limit.
  1. Remove the antenna from the EUT and then connect to a low loss RF cable from the antenna port to a spectrum analyzer
  2. Turn on the EUT and make it operate in transmitting mode. Then set it to Low Channel and High Channel within its operating range, and make sure the instrument is operated in its linear range.
  3. Set spectrum analyzer RBW =100 kHz, VBW=300 kHz, Detector=RMS, Sweep point= $\geq 2 \times$  span / RBW, Sweep time=Auto, trace= Average( 100 traces)
  4. Marker the highest point which fall into restricted frequency bands
  5. Repeat above procedures until all measured frequencies were complete.

Note: This test procedure is used for WIFI in this report

- This procedure shall be used if maximum peak conducted output power was used to demonstrate compliance to the output power limit.
  1. Remove the antenna from the EUT and then connect to a low loss RF cable from the antenna port to a spectrum analyzer
  2. Turn on the EUT and make it operate in transmitting mode. Then set it to Low Channel and High Channel within its operating range, and make sure the instrument is operated in its linear range.
  3. Set spectrum analyzer RBW =100 kHz, VBW=300 kHz, Detector=peak, Sweep time=Auto, trace=maxhold
  4. Marker the highest point which fall into restricted frequency bands
  5. Repeat above procedures until all measured frequencies were complete.

Note: This test procedure is used for BT4.0 in this report

### Test Procedure for radiated method

1. The EUT was placed on the top of a rotating table 0.8 meters above the ground at a 3 meter anechoic chamber. The table was rotated 360 degrees to determine the position of the highest radiation.
2. The EUT was set 3 meters away from the interference receiving antenna, which was mounted on the top of a variable height antenna tower.
3. The antenna height is varied from one meter to four meters above the ground to determine the maximum value of the field strength. Both horizontal and vertical polarizations of the antenna are set to make the measurement.
4. For each suspected emission, the EUT was arranged to its worst case and then the antenna was tuned to heights from 1 meter to 4 meters and the rotatable table was turned from 0 degrees to 360 degrees to find the maximum reading.
5. The test-receiver system was set to Peak Detect Function and Specified Bandwidth with Maximum Hold Mode.
6. Place a marker at the end of the restricted band closest to the transmit frequency to show compliance. Also measure any emissions in the restricted bands. Save the spectrum analyzer plot. Repeat for each power and modulation for lowest and highest channel
7. Test the EUT in the lowest channel, the highest channel
8. The radiation measurements are performed in X, Y, Z axis positioning. And found the X axis positioning which it is worse case, only the test worst case mode is recorded in the report.
9. Repeat above procedures until all frequencies measured was complete.



**Test Results**

**A. Conducted measurements**

802.11b			
Frequency (MHz)	Delta Peak to Band emission (dBc)	Limit (dBc)	Verdict
2378.987	45.400	20	PASS
2487.000	40.930	20	PASS

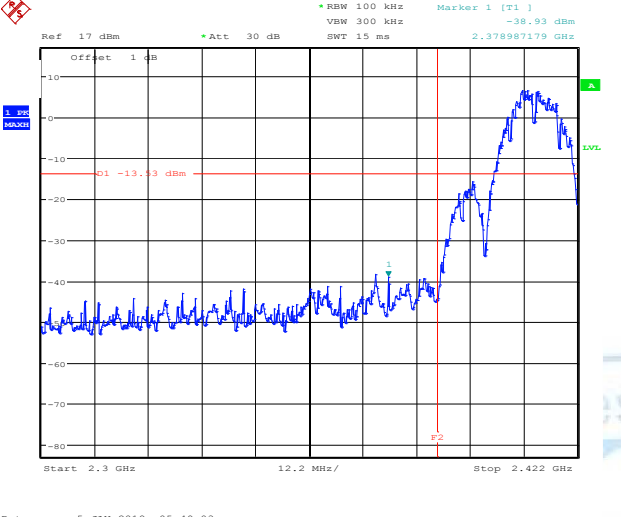

Date: 5.JAN.2018 05:49:03

**2412**

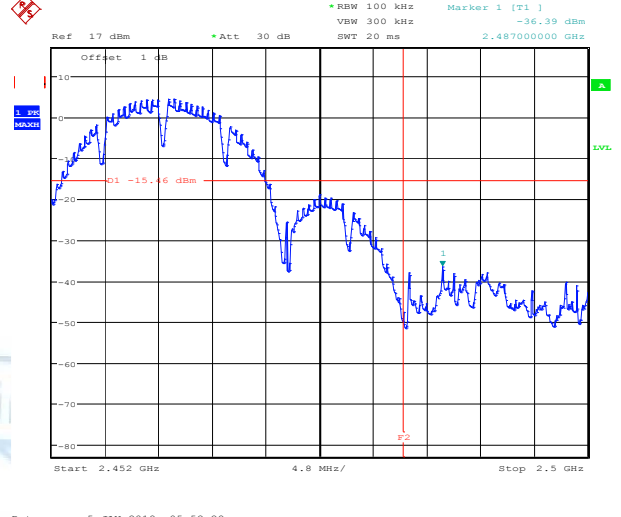

Date: 5.JAN.2018 05:52:28

**2462**

802.11g			
Frequency (MHz)	Delta Peak to Band emission (dBc)	Limit (dBc)	Verdict
2389.545	35.510	20	PASS
2483.846	36.180	20	PASS

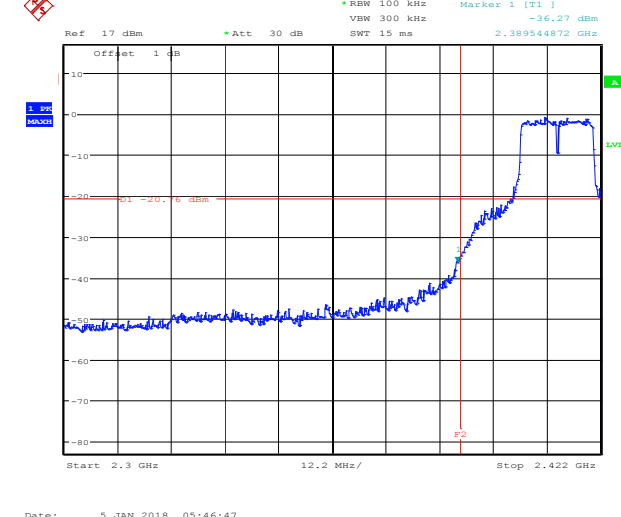

Date: 5.JAN.2018 05:46:47

**2412**

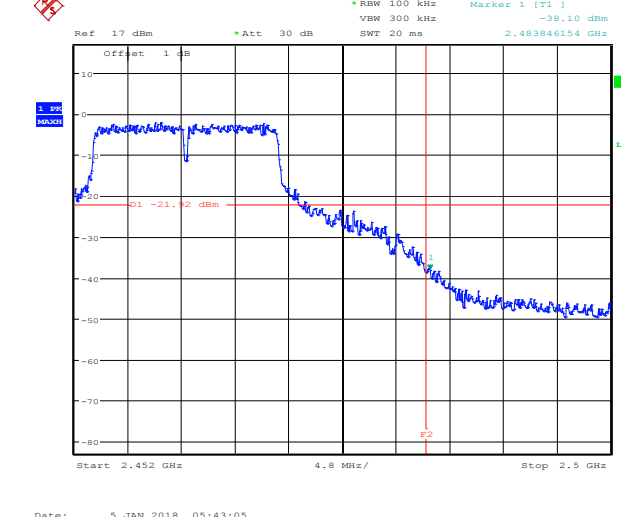

Date: 5.JAN.2018 05:43:05

**2462**

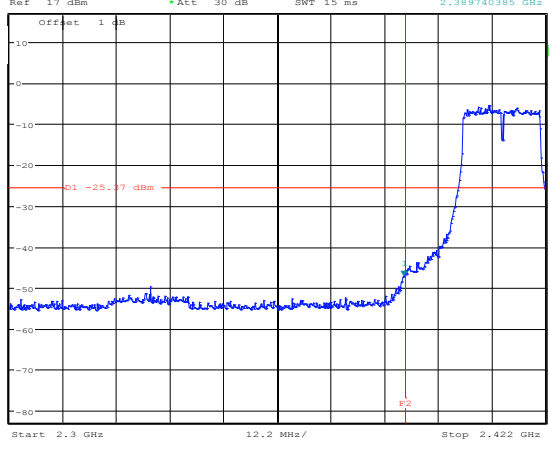
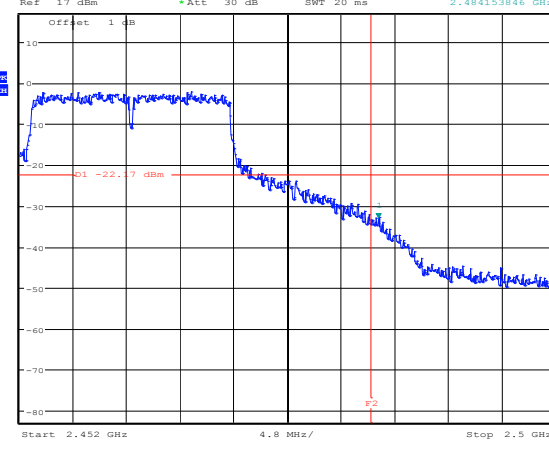

802.11n20			
Frequency (MHz)	Delta Peak to Band emission (dBc)	Limit (dBc)	Verdict
2389.740	41.780	20	PASS
2484.154	30.930	20	PASS
 <p>Ref: 17 dBm, Att: 30 dB, RBW: 100 kHz, VBW: 300 kHz, SWT: 15 ms, Marker 1 [T1]: -47.15 dBm, 2.389740395 GHz</p> <p>Offset: 1 dB, D1: -25.17 dBm</p> <p>Start: 2.3 GHz, 12.2 MHz/, Stop: 2.422 GHz</p> <p>Date: 5.JAN.2018 05:57:55</p>		 <p>Ref: 17 dBm, Att: 30 dB, RBW: 100 kHz, VBW: 300 kHz, SWT: 20 ms, Marker 1 [T1]: -33.10 dBm, 2.484153866 GHz</p> <p>Offset: 1 dB, D1: -22.17 dBm</p> <p>Start: 2.452 GHz, 4.8 MHz/, Stop: 2.5 GHz</p> <p>Date: 5.JAN.2018 05:54:51</p>	
2412		2462	

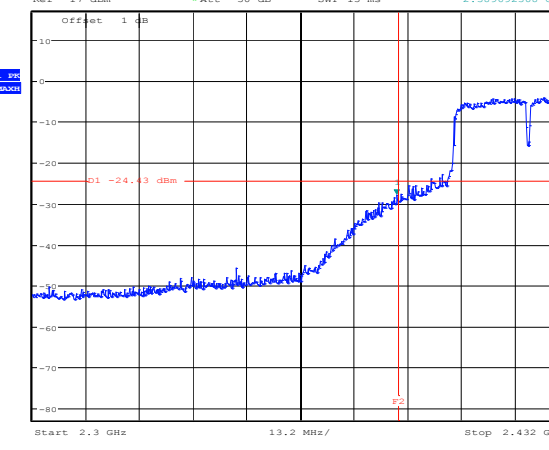
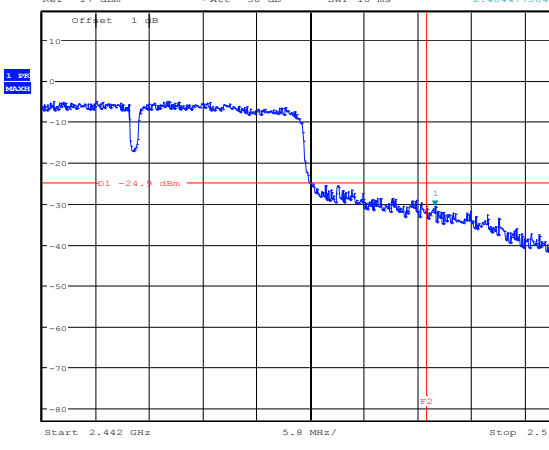
802.11n40			
Frequency (MHz)	Delta Peak to Band emission (dBc)	Limit (dBc)	Verdict
2389.692	23.480	20	PASS
2484.478	25.630	20	PASS
 <p>Ref: 17 dBm, Att: 30 dB, RBW: 100 kHz, VBW: 300 kHz, SWT: 15 ms, Marker 1 [T1]: -27.91 dBm, 2.389692308 GHz</p> <p>Offset: 1 dB, D1: -24.13 dBm</p> <p>Start: 2.3 GHz, 13.2 MHz/, Stop: 2.432 GHz</p> <p>Date: 5.JAN.2018 06:01:58</p>		 <p>Ref: 17 dBm, Att: 30 dB, RBW: 100 kHz, VBW: 300 kHz, SWT: 10 ms, Marker 1 [T1]: -30.53 dBm, 2.484477564 GHz</p> <p>Offset: 1 dB, D1: -24.1 dBm</p> <p>Start: 2.442 GHz, 5.8 MHz/, Stop: 2.5 GHz</p> <p>Date: 5.JAN.2018 06:04:29</p>	
2422		2452	

**B. Radiated measurements**

802.11b									
Polar	Frequenc y	Meter Reading	Pre-amplif ier	Cable Loss	Antenna Factor	Emission Level	Limits	Margin	Detector
(H/V)	(MHz)	(dBuV)	(dB)	(dB)	(dB/m)	(dBuV/m)	(dBuV/m)	(dB)	Type
H	2390.00	43.12	36.12	3.32	27.5	37.82	74	-36.18	PK
H	2390.00	37.54	36.12	3.32	27.5	32.24	54	-21.76	AV
V	2390.00	42.68	36.12	3.32	27.5	37.38	74	-36.62	PK
V	2390.00	36.36	36.12	3.32	27.5	31.06	54	-22.94	AV

802.11b									
Polar	Frequenc y	Meter Reading	Pre-amplif ier	Cable Loss	Antenna Factor	Emission Level	Limits	Margin	Detector
(H/V)	(MHz)	(dBuV)	(dB)	(dB)	(dB/m)	(dBuV/m)	(dBuV/m)	(dB)	Type
H	2483.50	42.51	36.12	3.32	27.5	37.21	74	-36.79	PK
H	2483.50	33.84	36.12	3.32	27.5	28.54	54	-25.46	AV
V	2483.50	43.19	36.12	3.32	27.5	37.89	74	-36.11	PK
V	2483.50	34.85	36.12	3.32	27.5	29.55	54	-24.45	AV

802.11g									
Polar	Frequenc y	Meter Reading	Pre-amplif ier	Cable Loss	Antenna Factor	Emission Level	Limits	Margin	Detector
(H/V)	(MHz)	(dBuV)	(dB)	(dB)	(dB/m)	(dBuV/m)	(dBuV/m)	(dB)	Type
H	2390.00	44.82	36.12	3.32	27.5	39.52	74	-34.48	PK
H	2390.00	36.87	36.12	3.32	27.5	31.57	54	-22.43	AV
V	2390.00	44.96	36.12	3.32	27.5	39.66	74	-34.34	PK
V	2390.00	35.48	36.12	3.32	27.5	30.18	54	-23.82	AV

802.11g									
Polar	Frequenc y	Meter Reading	Pre-amplif ier	Cable Loss	Antenna Factor	Emission Level	Limits	Margin	Detector
(H/V)	(MHz)	(dBuV)	(dB)	(dB)	(dB/m)	(dBuV/m)	(dBuV/m)	(dB)	Type
H	2483.50	43.12	36.12	3.32	27.5	37.82	74	-36.18	PK
H	2483.50	32.46	36.12	3.32	27.5	27.16	54	-26.84	AV
V	2483.50	44.12	36.12	3.32	27.5	38.82	74	-35.18	PK
V	2483.50	34.85	36.12	3.32	27.5	29.55	54	-24.45	AV

802.11n(H20)									
Polar	Frequenc y	Meter Reading	Pre-amplif ier	Cable Loss	Antenna Factor	Emission Level	Limits	Margin	Detector
(H/V)	(MHz)	(dBuV)	(dB)	(dB)	(dB/m)	(dBuV/m)	(dBuV/m)	(dB)	Type
H	2390.00	44.24	36.12	3.32	27.5	38.94	74	-35.06	PK
H	2390.00	36.03	36.12	3.32	27.5	30.73	54	-23.27	AV
V	2390.00	43.98	36.12	3.32	27.5	38.68	74	-35.32	PK
V	2390.00	34.86	36.12	3.32	27.5	29.56	54	-24.44	AV

802.11n(H20)									
Polar	Frequenc y	Meter Reading	Pre-amplif ier	Cable Loss	Antenna Factor	Emission Level	Limits	Margin	Detector
(H/V)	(MHz)	(dBuV)	(dB)	(dB)	(dB/m)	(dBuV/m)	(dBuV/m)	(dB)	Type
H	2483.50	44.35	36.12	3.32	27.5	39.05	74	-34.95	PK
H	2483.50	33.48	36.12	3.32	27.5	28.18	54	-25.82	AV
V	2483.50	44.29	36.12	3.32	27.5	38.99	74	-35.01	PK
V	2483.50	33.54	36.12	3.32	27.5	28.24	54	-25.76	AV

802.11n(H40)									
Polar	Frequenc y	Meter Reading	Pre-amplif ier	Cable Loss	Antenna Factor	Emission Level	Limits	Margin	Detector
(H/V)	(MHz)	(dBuV)	(dB)	(dB)	(dB/m)	(dBuV/m)	(dBuV/m)	(dB)	Type
H	2390.00	45.74	36.12	3.32	27.5	40.44	74	-33.56	PK
H	2390.00	35.11	36.12	3.32	27.5	29.81	54	-24.19	AV
V	2390.00	43.57	36.12	3.32	27.5	38.27	74	-35.73	PK
V	2390.00	34.19	36.12	3.32	27.5	28.89	54	-25.11	AV
802.11n(H40)									
Polar	Frequenc y	Meter Reading	Pre-amplif ier	Cable Loss	Antenna Factor	Emission Level	Limits	Margin	Detector
(H/V)	(MHz)	(dBuV)	(dB)	(dB)	(dB/m)	(dBuV/m)	(dBuV/m)	(dB)	Type
H	2483.50	44.62	36.12	3.32	27.5	39.32	74	-34.68	PK
H	2483.50	34.51	36.12	3.32	27.5	29.21	54	-24.79	AV
V	2483.50	44.38	36.12	3.32	27.5	39.08	74	-34.92	PK
V	2483.50	34.02	36.12	3.32	27.5	28.72	54	-25.28	AV

REMARKS:

1. Emission level (dBuV/m) =Raw Value (dBuV)+Correction Factor (dB/m)
2. Correction Factor (dB/m) = Antenna Factor (dB/m)+Cable Factor (dB)-Pre-amplifier Factor
3. Margin value = Limit value- Emission level.
4. -- Mean the PK detector measured value is below average limit.
5. The other emission levels were very low against the limit.

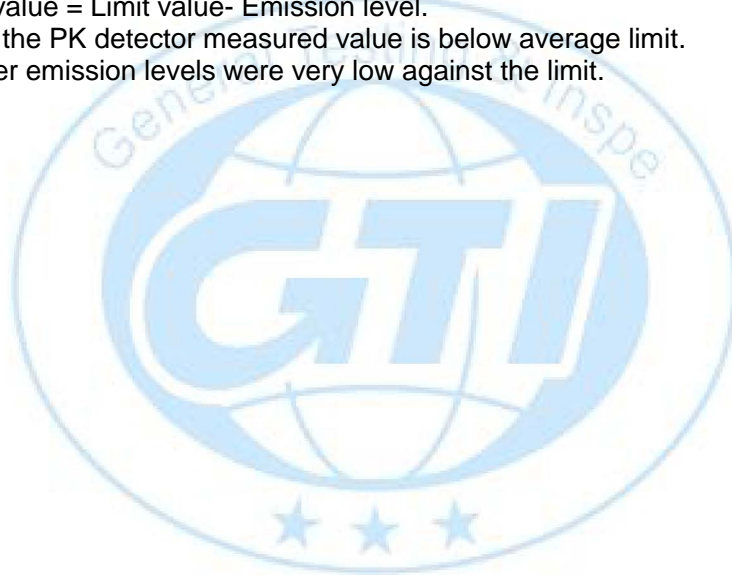

### 3.7. Antenna Requirement

#### Standard Applicable

For intentional device, according to FCC 47 CFR Section 15.203:

An intentional radiator shall be designed to ensure that no antenna other than that furnished by the responsible party shall be used with the device. The use of a permanently attached antenna or of an antenna that uses a unique coupling to the intentional radiator, the manufacturer may design the unit so that a broken antenna can be replaced by the user, but the use of a standard antenna jack or electrical connector is prohibited

Result

The EUT's antenna used a Antenna, soldered on the PCB., The antenna's gain is 3 dBi. Complying with the standard requirement.

#### Test Result:

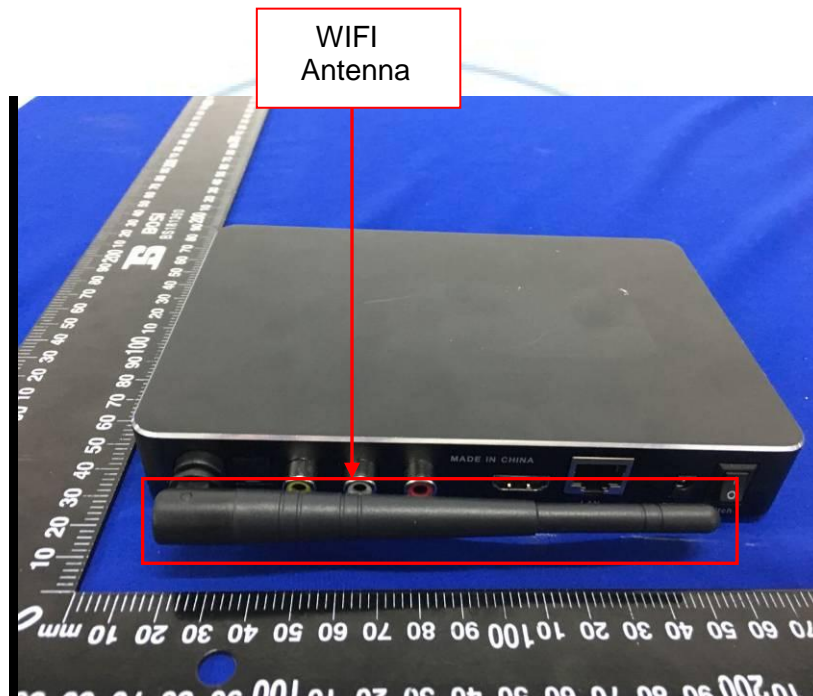

## 4. EUT TEST PHOTO

Conducted Emission



Radiated Emission



## 5. PHOTOGRAPHS OF EUT CONSTRUCTIONAL

External Photos of EUT Main Model

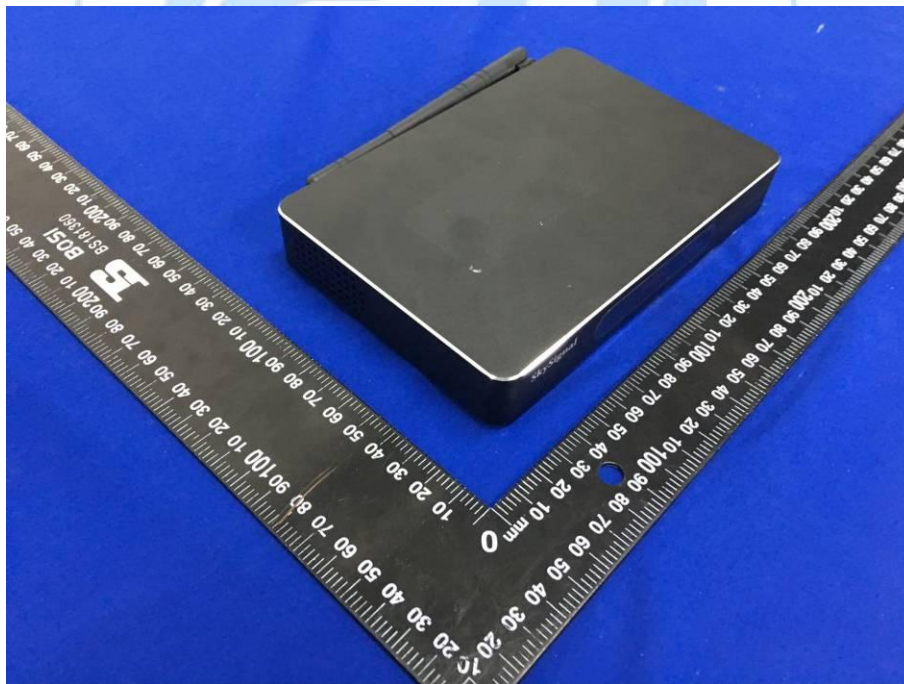



**Internal Photos of EUT**

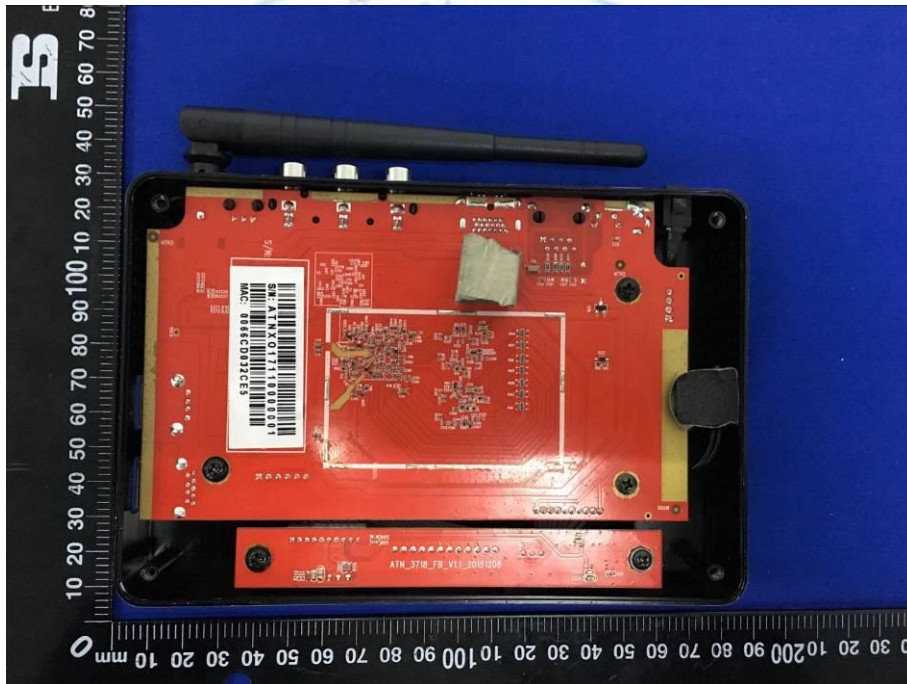

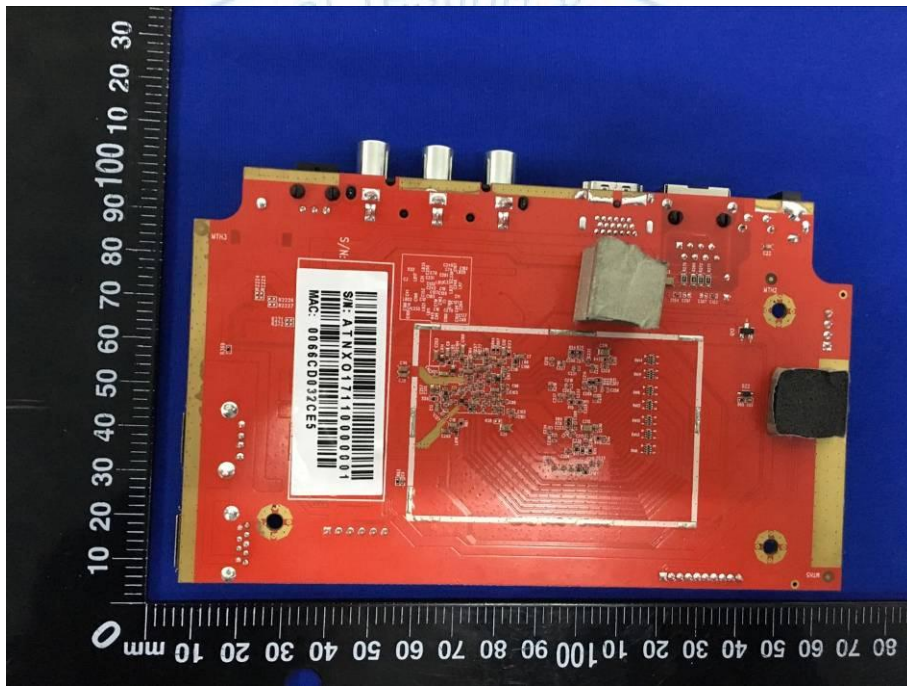
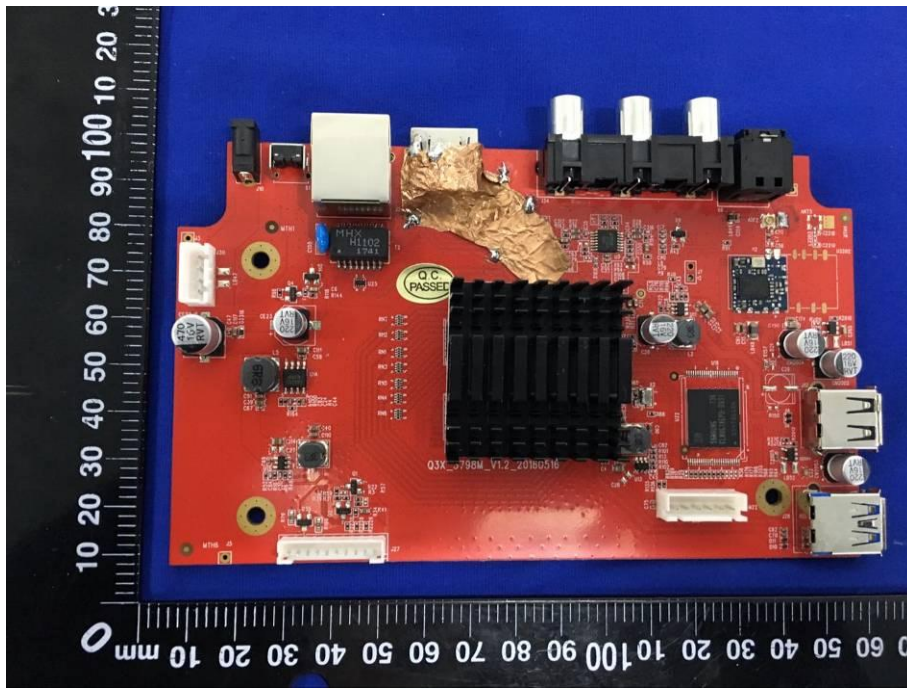



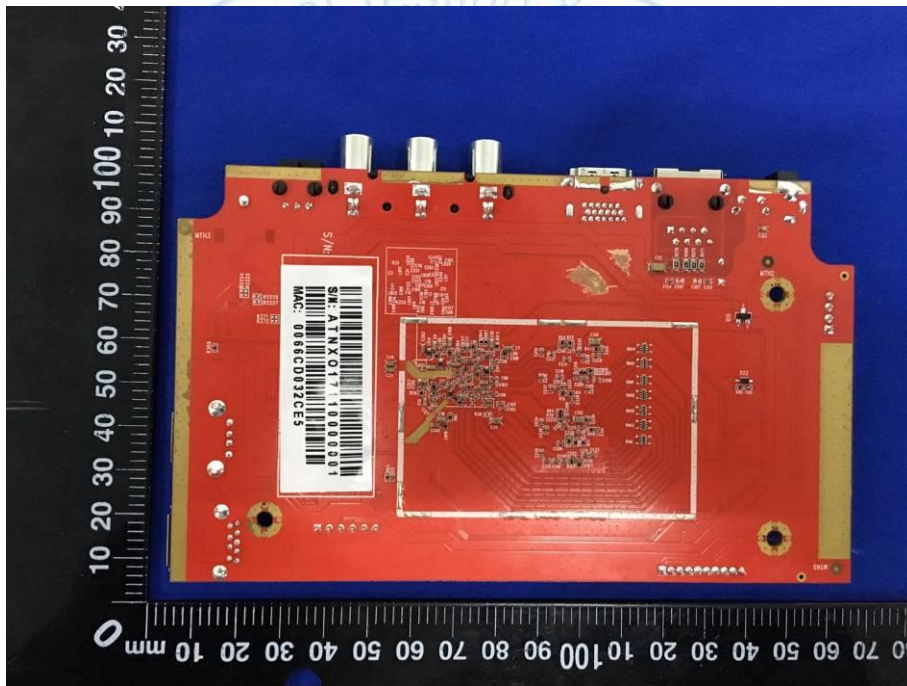
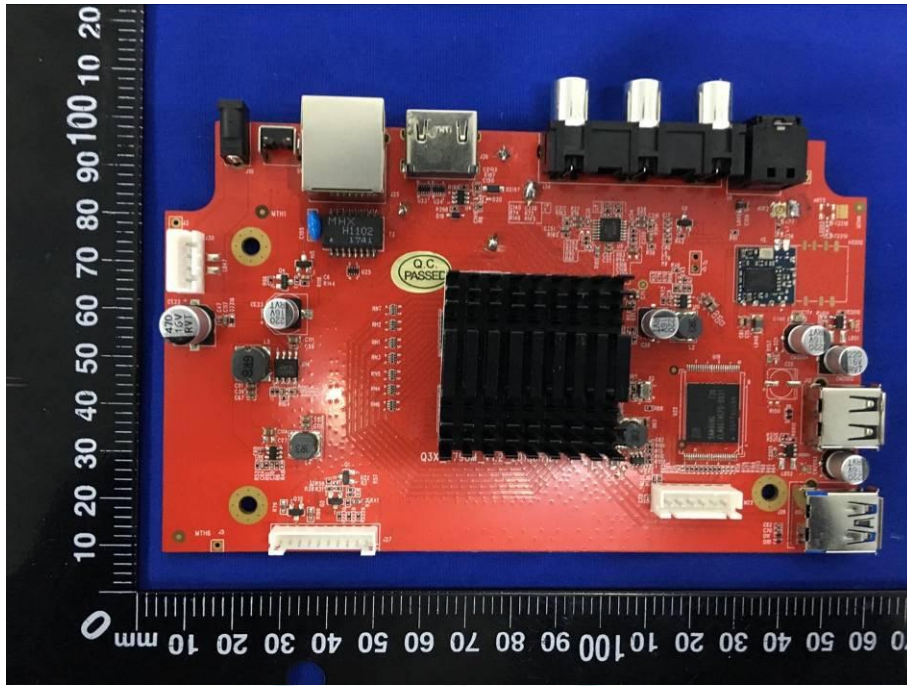

Shenzhen General Testing & Inspection Technology Co., Ltd.

1-2/F., Building 2, Jiaquan Building, Guanlan High-Tech Park, Shenzhen, Guangdong, China  
Tel.: (86)755-27521059 Fax.: (86)755-27521011 Http://www.sz-ctc.org.cn

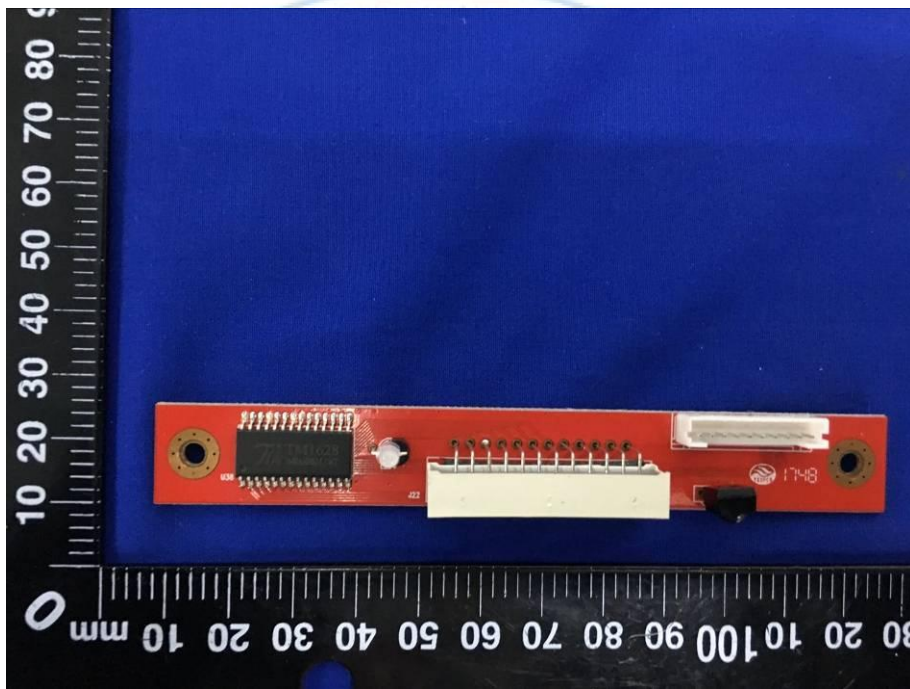

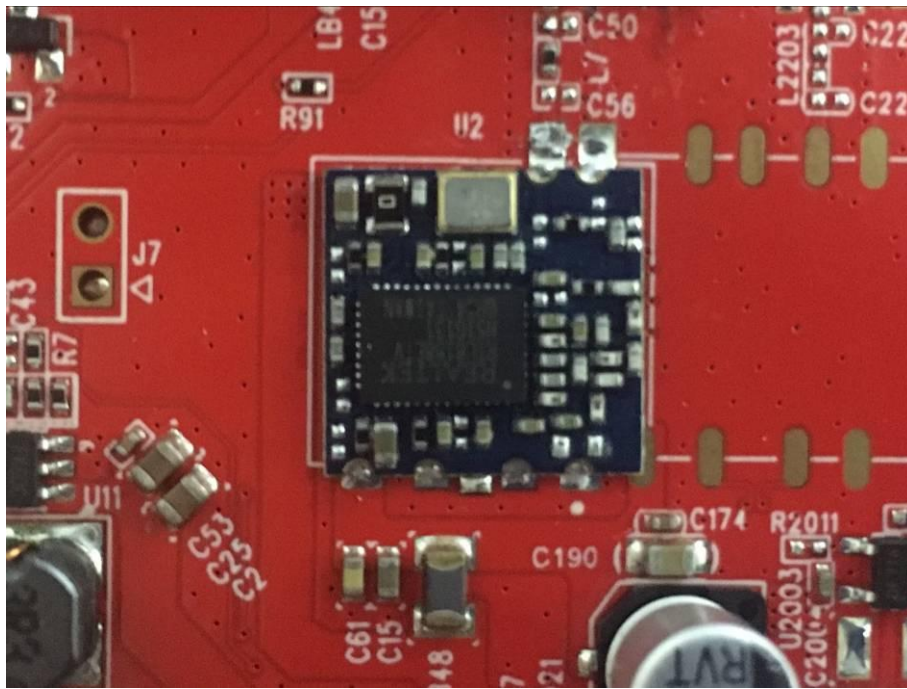

\*\*\*\*\*THE END\*\*\*\*\*

