



# RADIO TEST REPORT

Report No.:STS2102009W18

Issued for

Shenzhen UniStrong Science & Technology Co.,Ltd.

B,4-4Factory, Zhengcheng Road, FuyongBaoan District,  
Shenzhen, China

<b>Product Name:</b>	Rugged Smart Phone
<b>Brand Name:</b>	N/A
<b>Model Name:</b>	UT12P
<b>Series Model:</b>	N/A
<b>FCC ID:</b>	2AOPD-UT12P
<b>Test Standard:</b>	FCC Part 15.407

Any reproduction of this document must be done in full. No single part of this document may be reproduced without permission from STS, all test data presented in this report is only applicable to presented test sample.

Shenzhen STS Test Services Co., Ltd.  
A 1/F, Building B, Zhuoke Science Park, No.190 Chongqing Road, HepingShequ,  
Fuyong Sub-District, Bao'an District, Shenzhen, Guang Dong, China  
TEL: +86-755 3688 6288 FAX: +86-755 3688 6277 E-mail:sts@stsapp.com





### TEST RESULT CERTIFICATION

**Applicant's Name**..... : Shenzhen UniStrong Science & Technology Co.,Ltd.  
**Address** ..... : B,4-4Factory, Zhengcheng Road, FuyongBaoan District, Shenzhen, China  
**Manufacturer's Name** ..... : Shenzhen UniStrong Science & Technology Co.,Ltd.  
**Address** ..... : B,4-4Factory, Zhengcheng Road, FuyongBaoan District, Shenzhen, China

**Product Description**

**Product Name**..... : Rugged Smart Phone  
**Brand Name** ..... : N/A  
**Model Name** ..... : UT12P  
**Series Model**..... : N/A

**Test Standards** ..... : FCC Part15.407

**Test Procedure**..... ANSI C63.10-2013

This device described above has been tested by STS, the test results show that the equipment under test (EUT) is in compliance with the FCC requirements. And it is applicable only to the tested sample identified in the report.

This report shall not be reproduced except in full, without the written approval of STS, this document only be altered or revised by STS, personal only, and shall be noted in the revision of the document.

**Date of Test** ..... :  
**Date of receipt of test item** ..... : 01 Feb. 2021  
**Date (s) of performance of tests** ..... : 01 Feb. 2021 ~ 03 Mar. 2021  
**Date of Issue**..... : 03 Mar. 2021  
**Test Result**..... : **Pass**

Testing Engineer :   
 \_\_\_\_\_  
 (Chris Chen)

Technical Manager :   
 \_\_\_\_\_  
 (Sean she)

Authorized Signatory :   
 \_\_\_\_\_  
 (Vita Li)





Table of Contents	Page
<b>1 . SUMMARY OF TEST RESULTS</b>	<b>6</b>
1.1 TEST FACTORY	7
1.2 MEASUREMENT UNCERTAINTY	7
<b>2 . GENERAL INFORMATION</b>	<b>8</b>
2.1 GENERAL DESCRIPTION OF THE EUT	8
2.2 DESCRIPTION OF TEST MODES	10
2.3 TEST SOFTWARE AND POWER LEVEL	11
2.4 BLOCK DIAGRAM SHOWING THE CONFIGURATION OF SYSTEM TESTED	12
2.5 DESCRIPTION OF NECESSARY ACCESSORIES AND SUPPORT UNITS	13
2.6 EQUIPMENTS LIST FOR ALL TEST ITEMS	14
<b>3 . EMC EMISSION TEST</b>	<b>15</b>
3.1 CONDUCTED EMISSION MEASUREMENT	15
3.2 RADIATED EMISSION AND ( BANDEDGE) MEASUREMENT	19
<b>4. POWER SPECTRAL DENSITY TEST</b>	<b>43</b>
4.1 LIMIT	43
4.2 TEST PROCEDURE	43
4.3 DEVIATION FROM STANDARD	43
4.4 TEST SETUP	44
4.5 EUT OPERATION CONDITIONS	44
4.6 TEST RESULTS	44
<b>5. BANDWIDTH MEASUREMENT</b>	<b>46</b>
5.1 EMISSION BANDWIDTH (EBW) 26 BANDWID PROCEDURES / LIMIT	46
5.2 OCCUPIED BANDWIDTH ( 99%) TEST APPLIED PROCEDURES / LIMIT	48
5.3 MINIMUM EMISSION BANDWIDTH(6 DB) PROCEDURES / LIMIT	50
<b>6. MAXIMUM CONDUCTED OUTPUT POWER</b>	<b>52</b>
6.1 LIMIT	52
6.2 TEST PROCEDURE	52
6.3 DEVIATION FROM STANDARD	52
6.4 TEST SETUP	52
6.5 EUT OPERATION CONDITIONS	52
6.6 TEST RESULTS	53
<b>7. AUTOMATICALLY DISCONTINUE TRANSMISSION</b>	<b>59</b>
7.1 LIMIT OF AUTOMATICALLY DISCONTINUE TRANSMISSION	59
7.2 TEST RESULT OF AUTOMATICALLY DISCONTINUE TRANSMISSION	59



Table of Contents	Page
<b>8. ANTENNA REQUIREMENT</b>	<b>60</b>
8.1 STANDARD REQUIREMENT	60
8.2 EUT ANTENNA	60
<b>APPENDIX - PHOTOS OF TEST SETUP</b>	<b>61</b>





**Revision History**

Rev.	Issue Date	Report NO.	Effect Page	Contents
00	03 Mar. 2021	STS2102009W18	ALL	Initial Issue





## 1. SUMMARY OF TEST RESULTS

Test procedures according to the technical standards:

§ 15.407, KDB 789033 D02 General U-NII Test Procedures New Rules v02r01.

FCC Part 15.407		
FCC standard	Test Item	Results
15.207	AC Conducted Emission	PASS
15.407 (a) /15.407 (e)	26dB/6dB &99% Bandwidth	PASS
15.407(a)	Maximum Conducted Output Power	PASS
15.407(b)/15.205/15.209	Radiated Emission And (bandedge Emissions) Measurement	PASS
15.407(a)	Power Spectral Density	PASS
15.407(c)	Automatically Discontinue Transmission	PASS
15.203	Antenna Requirement	PASS

### NOTE:

(1) 'N/A' denotes test is not applicable in this Test Report.

(2) All tests are according to ANSI C63.10-2013.



## 1.1 TEST FACTORY

SHENZHEN STS TEST SERVICES CO., LTD

Add. : A 1/F, Building B, Zhuoke Science Park, No.190 Chongqing Road, HepingShequ, Fuyong Sub-District, Bao'an District, Shenzhen, Guang Dong, China

FCC test Firm Registration Number: 625569

IC test Firm Registration Number: 12108A

A2LA Certificate No.: 4338.01

## 1.2 MEASUREMENT UNCERTAINTY

The reported uncertainty of measurement  $y \pm U$ , where expanded uncertainty  $U$  is based on a standard uncertainty multiplied by a coverage factor of  $k=2$ , providing a level of confidence of approximately **95 %**.

No.	Item	Uncertainty
1	RF output power, conducted	$\pm 0.68\text{dB}$
2	Unwanted Emissions, conducted	$\pm 2.988\text{dB}$
3	All emissions, radiated 9K-30MHz	$\pm 2.84\text{dB}$
4	All emissions, radiated 30M-1GHz	$\pm 4.39\text{dB}$
5	All emissions, radiated 1G-6GHz	$\pm 5.10\text{dB}$
6	All emissions, radiated >6G	$\pm 5.48\text{dB}$
7	Conducted Emission (9KHz-150KHz)	$\pm 2.79\text{dB}$
8	Conducted Emission (150KHz-30MHz)	$\pm 2.80\text{dB}$

## 2. GENERAL INFORMATION

### 2.1 GENERAL DESCRIPTION OF THE EUT

Product Name	Rugged Smart Phone												
Trade Name	N/A												
Model Name	UT12P												
Series Model	N/A												
Model Difference	N/A												
Product Description	The EUT is a Rugged Smart Phone												
	<table border="1"> <tr> <td rowspan="3">Operation Frequency:</td> <td>IEEE 802.11a/ n(HT20)/ac(VHT20): 5.180GHz-5.240GHz</td> </tr> <tr> <td>IEEE 802.11n(HT40)/ac(VHT40): 5.190GHz-5.230GHz</td> </tr> <tr> <td>IEEE 802.11ac(VHT80): 5.210GHz</td> </tr> <tr> <td rowspan="3">Modulation Type:</td> <td>IEEE 802.11a/ n(HT20)/ac(VHT20): 5.745GHz-5.825GHz</td> </tr> <tr> <td>IEEE 802.11n(HT40)/ac(VHT40): 5.755GHz-5.795GHz</td> </tr> <tr> <td>IEEE 802.11ac(VHT80): 5.775GHz</td> </tr> <tr> <td>Antenna Designation:</td> <td>Please refer to the Note 3.</td> </tr> <tr> <td>Max.Output Power(Conducted):</td> <td>9.75 dBm</td> </tr> </table>	Operation Frequency:	IEEE 802.11a/ n(HT20)/ac(VHT20): 5.180GHz-5.240GHz	IEEE 802.11n(HT40)/ac(VHT40): 5.190GHz-5.230GHz	IEEE 802.11ac(VHT80): 5.210GHz	Modulation Type:	IEEE 802.11a/ n(HT20)/ac(VHT20): 5.745GHz-5.825GHz	IEEE 802.11n(HT40)/ac(VHT40): 5.755GHz-5.795GHz	IEEE 802.11ac(VHT80): 5.775GHz	Antenna Designation:	Please refer to the Note 3.	Max.Output Power(Conducted):	9.75 dBm
	Operation Frequency:		IEEE 802.11a/ n(HT20)/ac(VHT20): 5.180GHz-5.240GHz										
			IEEE 802.11n(HT40)/ac(VHT40): 5.190GHz-5.230GHz										
		IEEE 802.11ac(VHT80): 5.210GHz											
	Modulation Type:	IEEE 802.11a/ n(HT20)/ac(VHT20): 5.745GHz-5.825GHz											
IEEE 802.11n(HT40)/ac(VHT40): 5.755GHz-5.795GHz													
IEEE 802.11ac(VHT80): 5.775GHz													
Antenna Designation:	Please refer to the Note 3.												
Max.Output Power(Conducted):	9.75 dBm												
More details of EUT technical specification, please refer to the User's Manual.													
Test Channel	Please refer to the Note 2.												
Adapter	Input: AC 100-240V 50/60Hz 0.7A Output: DC 5V 3A or 9V 2A or 12V 1.5A												
Battery	Rated Voltage:3.8V Charge Limit Voltage:4.35V Capacity: 8000mAh												
Hardware version number	C602_MB_PCB_V102												
Software version number	RP00.53.84.08												
Connecting I/O Port(s)	Please refer to the Note 1.												

Note:

1. For a more detailed features description, please refer to the manufacturer's specifications or the User Manual.





2. Operation Frequency of channel			
5.180GHz-5.240GHz		5.745GHz-5.825GHz	
Channel	Frequency	Channel	Frequency
36	5180	149	5745
38	5190	151	5755
40	5200	153	5765
42	5210	157	5785
44	5220	159	5795
46	5230	161	5805
48	5240	165	5825

Note:

In section 15.31(m), regards to the operating frequency range over 10 MHz, the Lowest frequency, the middle frequency, and the highest frequency of channel were selected to perform the test, and the selected channel see below:

Carrier Frequency Channel

5GHz:

For 802.11a/n(HT20) /ac (VHT20)			
Channel	Freq.(MHz)	Channel	Freq.(MHz)
36	5180	149	5745
40	5200	157	5785
48	5240	165	5825

For 802.11n(HT40) /ac (VHT40)			
Channel	Freq.(MHz)	Channel	Freq.(MHz)
38	5190	151	5755
46	5230	159	5795

For 802.11ac (VHT80)			
Channel	Freq.(MHz)	Channel	Freq.(MHz)
42	5210	155	5775

3.	Ant	Brand	Model Name	Ant Type	Connector	Gain (dBi)	NOTE
	A	N/A	UT12P	PIFA	N/A	Band 1: 2.31dBi Band 4: 3.29dBi	WLAN Ant.

Note: The antenna information refer the manufacturer provide report, applicable only to the tested sample identified in the report.



## 2.2 DESCRIPTION OF TEST MODES

To investigate the maximum EMI emission characteristics generated from EUT, the test system was pre-scanning tested based on the consideration of following EUT operation mode or test configuration mode which possibly have effect on EMI emission level. Each of these EUT operation mode(s) or test configuration mode(s) mentioned above was evaluated respectively.

Worst Mode	Description	Data Rate
Mode 1	TX IEEE 802.11a HT20 CH36&CH40&CH48	6 Mbps
Mode 2	TX IEEE 802.11a HT20 CH149&CH157&CH165	6 Mbps
Mode 3	TX IEEE 802.11n HT20 CH36&CH40&CH48	MCS 0
Mode 4	TX IEEE 802.11ac VHT20 CH36&CH40&CH48	NSS1 MCS0
Mode 5	TX IEEE 802.11n HT20 CH149&CH157&CH165	MCS 0
Mode 6	TX IEEE 802.11ac VHT20 CH149&CH157&CH165	NSS1 MCS0
Mode 7	TX IEEE 802.11n HT40 CH38&CH46	MCS 0
Mode 8	TX IEEE 802.11ac VHT40 CH38&CH46	NSS1 MCS0
Mode 9	TX IEEE 802.11n HT40 CH151&CH159	MCS 0
Mode 10	TX IEEE 802.11ac VHT40 CH151&CH159	NSS1 MCS0
Mode 11	TX IEEE 802.11ac VHT80 CH42	NSS1 MCS0
Mode 12	TX IEEE 802.11ac VHT80 CH155	NSS1 MCS0

- Note: (1) The measurements are performed at the highest, middle, lowest available channels.  
 (2) The measurements are performed at all Bit Rate of Transmitter, the worst data was reported.  
 (3) We have been tested for all available U.S. voltage and frequencies (For 120V, 50/60Hz and 240V, 50/60Hz) for which the device is capable of operation.  
 (4) The battery is fully-charged during the radiated and RF conducted test.

### AC Conducted Emission

Test Case	
AC Conducted Emission	Mode 13: Keeping TX + WLAN Link



**2.3 TEST SOFTWARE AND POWER LEVEL**

During testing channel & power controlling software provided by the customer was used to control the operating channel as well as the output power level.

RF Function	Type	Mode Or Modulation type	ANT Gain(dBi)	Power Class	Software For Testing
WIFI(5G)	5G WIFI Band1 (5150MHz-5250MHz)	802.11a	2.31	15	QRCT3
		802.11n(HT20)		15	
		802.11n(HT40)		15	
		802.11ac(VHT20)		15	
		802.11ac(VHT40)		15	
		802.11ac(VHT80)		7	
RF Function	Type	Mode Or Modulation type	ANT Gain(dBi)	Power Class	Software For Testing
WIFI(5G)	5G WIFI Band4 (5725MHz-5875MHz)	802.11a	3.29	15	QRCT3
		802.11n(HT20)		15	
		802.11n(HT40)		15	
		802.11ac(VHT20)		15	
		802.11ac(VHT40)		15	
		802.11ac(VHT80)		7	

## 2.4 BLOCK DIAGRAM SHOWING THE CONFIGURATION OF SYSTEM TESTED

### Radiated Spurious Emission Test

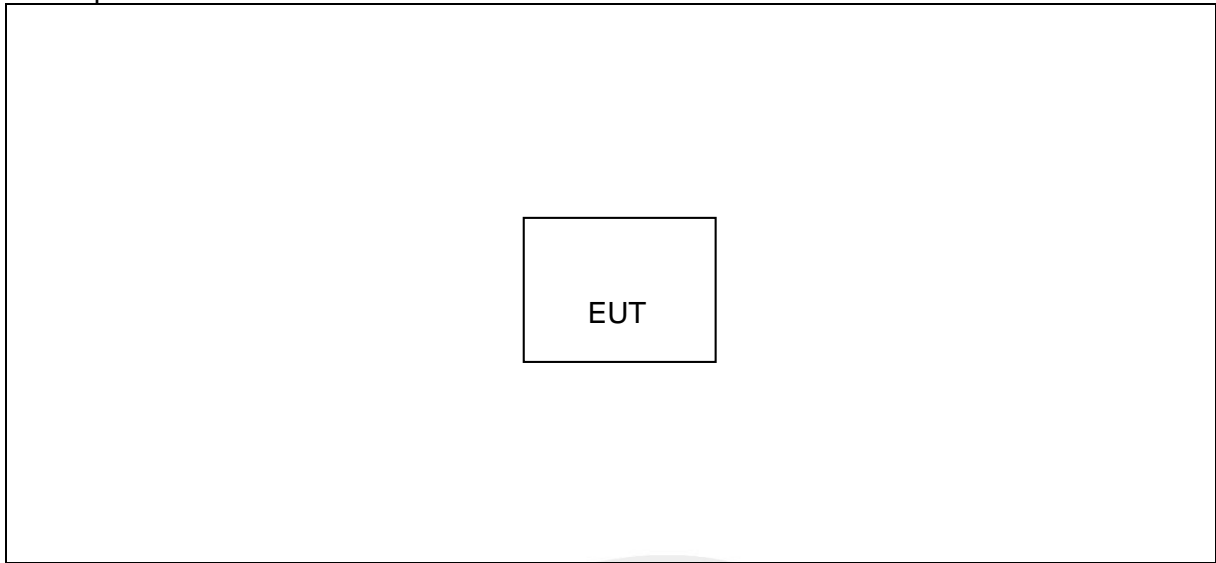

### Conducted Emission Test

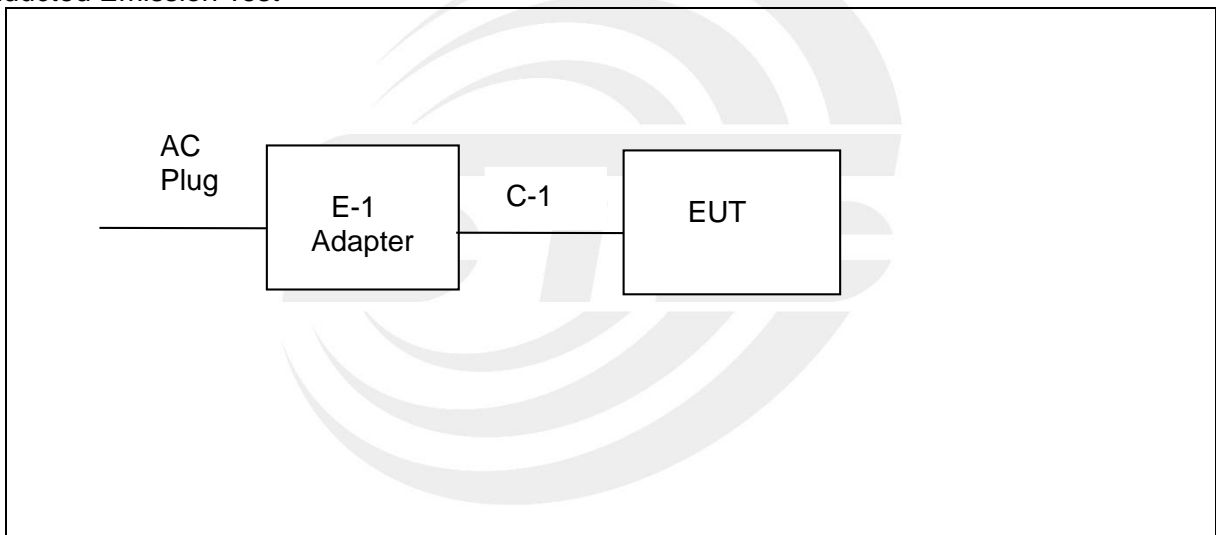



## 2.5 DESCRIPTION OF NECESSARY ACCESSORIES AND SUPPORT UNITS

The EUT has been tested as an independent unit together with other necessary accessories or support units. The following support units or accessories were used to form a representative test configuration during the tests.

### Necessary accessories

Item	Equipment	Mfr/Brand	Model/Type No.	Length	Note
E-1	Adapter	Aquilstar	ASUC71w-050912300	N/A	N/A
C-1	USB Cable	N/A	N/A	100cm	YES

### Support units

Item	Equipment	Mfr/Brand	Model/Type No.	Length	Note
N/A	N/A	N/A	N/A	N/A	N/A

#### Note:

- (1) For detachable type I/O cable should be specified the length in cm in 『Length』 column.
- (2) “YES” is means “with core”; “NO” is means “without core”.



**2.6 EQUIPMENTS LIST FOR ALL TEST ITEMS**

Radiation Test equipment

Kind of Equipment	Manufacturer	Type No.	Serial No.	Last calibration	Calibrated until
Test Receiver	R&S	ESCI	101427	2020.10.12	2021.10.11
Signal Analyzer	Agilent	N9020A	MY51110105	2020.10.10	2021.10.09
Active loop Antenna	ZHINAN	ZN30900C	16035	2019.07.11	2021.07.10
Bilog Antenna	TESEQ	CBL6111D	34678	2020.10.12	2022.10.11
Horn Antenna	SCHWARZBECK	BBHA 9120D(1201)	9120D-1343	2019.10.15	2021.10.14
SHF-EHF Horn Antenna (18G-40GHz)	A-INFO	LB-180400-KF	J211020657	2020.10.12	2022.10.11
Pre-Amplifier (0.1M-3GHz)	EM	EM330	060665	2020.10.12	2021.10.11
Pre-Amplifier (1G-18GHz)	SKET	LNPA-01018G-45	SK2018080901	2020.10.12	2021.10.11
Pre-Amplifier (18G-40GHz)	SKET	LNPA-1840-50	SK2018101801	2020.10.10	2021.10.09
Temperature & Humidity	HH660	Mieo	N/A	2020.10.13	2021.10.12
turn table	EM	SC100_1	60531	N/A	N/A
Antenna mast	EM	SC100	N/A	N/A	N/A
Test SW	FARAD	EZ-EMC(Ver.STSLAB-03A1 RE)			

Conduction Test equipment

Kind of Equipment	Manufacturer	Type No.	Serial No.	Last calibration	Calibrated until
Test Receiver	R&S	ESCI	101427	2020.10.12	2021.10.11
LISN	R&S	ENV216	101242	2020.10.12	2021.10.11
LISN	EMCO	3810/2NM	23625	2020.10.12	2021.10.11
Temperature & Humidity	HH660	Mieo	N/A	2020.10.12	2021.10.11
Test SW	FARAD	EZ-EMC(Ver.STSLAB-03A1 CE)			

RF Connected Test

Kind of Equipment	Manufacturer	Type No.	Serial No.	Last calibration	Calibrated until
Power Sensor	Keysight	U2021XA	MY55520005	2020.10.10	2021.10.09
			MY55520006	2020.10.10	2021.10.09
			MY56120038	2020.10.10	2021.10.09
			MY56280002	2020.10.10	2021.10.09
Signal Analyzer	Agilent	N9020A	MY51110105	2020.03.05	2021.03.04
Temperature & Humidity	HH660	Mieo	N/A	2020.10.13	2021.10.12



### 3. EMC EMISSION TEST

#### 3.1 CONDUCTED EMISSION MEASUREMENT

##### 3.1.1 POWER LINE CONDUCTED EMISSION Limits (Frequency Range 150KHz-30MHz)

FREQUENCY (MHz)	Class B (dBuV)		Standard
	Quasi-peak	Average	
0.15 -0.5	66 - 56 *	56 - 46 *	CISPR
0.50 -5.0	56.00	46.00	CISPR
5.0 -30.0	60.00	50.00	CISPR

0.15 -0.5	66 - 56 *	56 - 46 *	FCC
0.50 -5.0	56.00	46.00	FCC
5.0 -30.0	60.00	50.00	FCC

Note:

- (1) The tighter limit applies at the band edges.
- (2) The limit of “ \* ” marked band means the limitation decreases linearly with the logarithm of the frequency in the range.

The following table is the setting of the receiver

Receiver Parameters	Setting
Attenuation	10 dB
Start Frequency	0.15 MHz
Stop Frequency	30 MHz
IF Bandwidth	9 kHz

### 3.1.2 TEST PROCEDURE

- a. The EUT is 0.8 m from the horizontal ground plane and 0.4 m from the vertical ground plane with EUT being connected to the power mains through a line impedance stabilization network (LISN). All other support equipments are powered from additional LISN(s). The LISN provides 50 Ohm/ 50uH of coupling impedance for the measuring instrument.
- b. Interconnecting cables that hang closer than 40 cm to the ground plane shall be folded back and forth in the center forming a bundle 30 to 40 cm long.
- c. I/O cables that are not connected to a peripheral shall be bundled in the center. The end of the cable may be terminated, if required, using the correct terminating impedance. The overall length shall not exceed 1 m.
- d. LISN is at least 80 cm from the nearest part of EUT chassis.
- e. For the actual test configuration, please refer to the related Item –EUT Test Photos.

### 3.1.3 DEVIATION FROM TEST STANDARD

No deviation

### 3.1.4 TEST SETUP

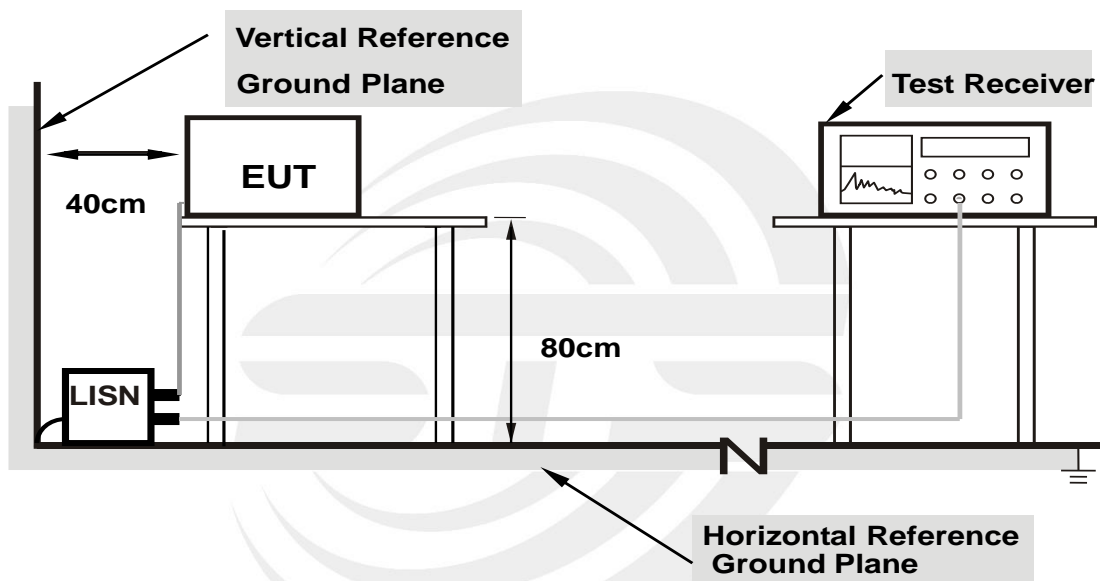

- Note: 1. Support units were connected to second LISN.**
- 2. Both of LISNs (AMN) are 80 cm from EUT and at least 80 cm from other units and other metal planes support units.**

### 3.1.5 EUT OPERATING CONDITIONS

The EUT was configured for testing in a typical fashion (as a customer would normally use it). The EUT has been programmed to continuously transmit during test. This operating condition was tested and used to collect the included data.





### 3.1.6 TEST RESULTS

Temperature:	26.8(C)	Relative Humidity:	66%RH
Test Voltage:	AC 120V/60Hz	Phase:	L
Test Mode :	Mode 13		

No.	Frequency (MHz)	Reading (dBuV)	Correct Factor(dB)	Result (dBuV)	Limit (dBuV)	Margin (dB)	Remark
1	0.1500	28.89	20.19	49.08	66.00	-16.92	QP
2	0.1500	14.83	20.19	35.02	56.00	-20.98	AVG
3	0.5620	29.71	20.38	50.09	56.00	-5.91	QP
4	0.5620	16.04	20.38	36.42	46.00	-9.58	AVG
5	1.3860	25.86	20.16	46.02	56.00	-9.98	QP
6	1.3860	9.62	20.16	29.78	46.00	-16.22	AVG
7	2.2780	26.33	20.13	46.46	56.00	-9.54	QP
8	2.2780	10.15	20.13	30.28	46.00	-15.72	AVG
9	4.5140	26.00	20.04	46.04	56.00	-9.96	QP
10	4.5140	11.09	20.04	31.13	46.00	-14.87	AVG
11	19.0660	16.61	20.54	37.15	60.00	-22.85	QP
12	19.0660	4.09	20.54	24.63	50.00	-25.37	AVG

Remark:

1. All readings are Quasi-Peak and Average values
2. Margin = Result (Result = Reading + Factor) – Limit
3. Factor=LISN factor+Cable loss+Limiter (10dB)

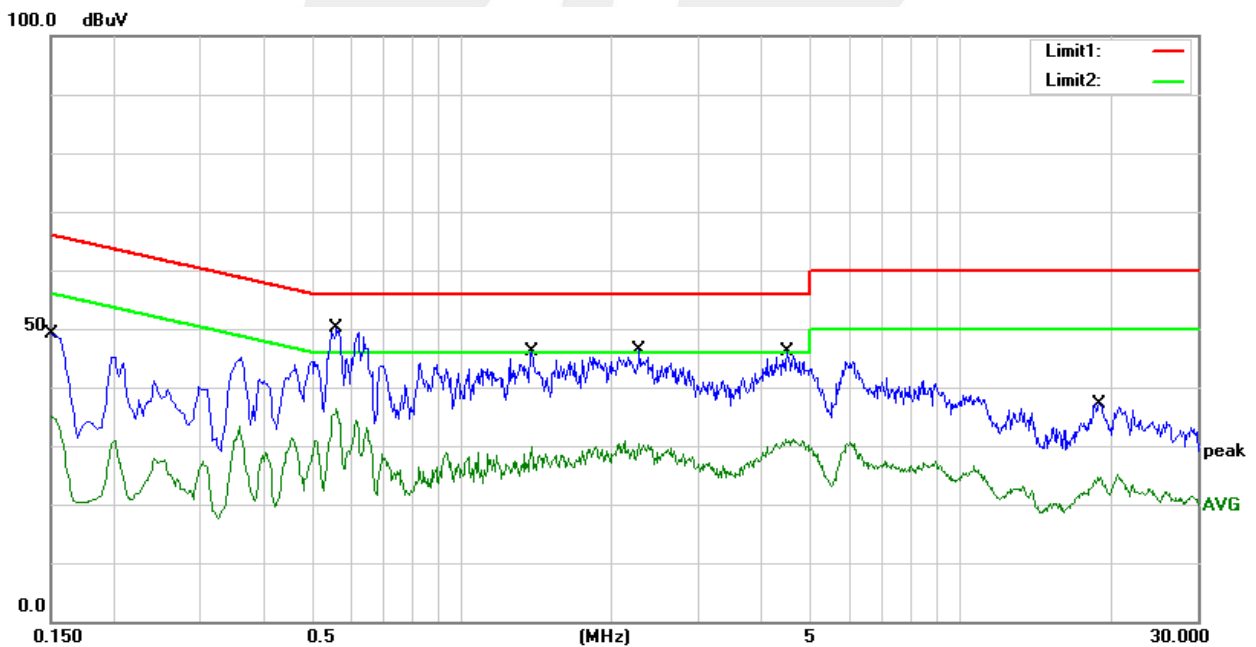



Temperature:	26.8(C)	Relative Humidity:	66%RH
Test Voltage	AC 120V/60Hz	Phase:	N
Test Mode	Mode 13		

No.	Frequency (MHz)	Reading (dBuV)	Correct Factor(dB)	Result (dBuV)	Limit (dBuV)	Margin (dB)	Remark
1	0.1500	28.28	20.19	48.47	66.00	-17.53	QP
2	0.1500	11.07	20.19	31.26	56.00	-24.74	AVG
3	0.5540	24.09	20.39	44.48	56.00	-11.52	QP
4	0.5540	12.32	20.39	32.71	46.00	-13.29	AVG
5	1.4820	22.63	20.15	42.78	56.00	-13.22	QP
6	1.4820	7.04	20.15	27.19	46.00	-18.81	AVG
7	3.9220	21.40	20.06	41.46	56.00	-14.54	QP
8	3.9220	6.70	20.06	26.76	46.00	-19.24	AVG
9	10.5380	17.82	19.86	37.68	60.00	-22.32	QP
10	10.5380	4.13	19.86	23.99	50.00	-26.01	AVG
11	20.5780	15.99	20.64	36.63	60.00	-23.37	QP
12	20.5780	4.17	20.64	24.81	50.00	-25.19	AVG

Remark:

1. All readings are Quasi-Peak and Average values
2. Margin = Result (Result =Reading + Factor )–Limit
3. Factor=LISN factor+Cable loss+Limiter (10dB)

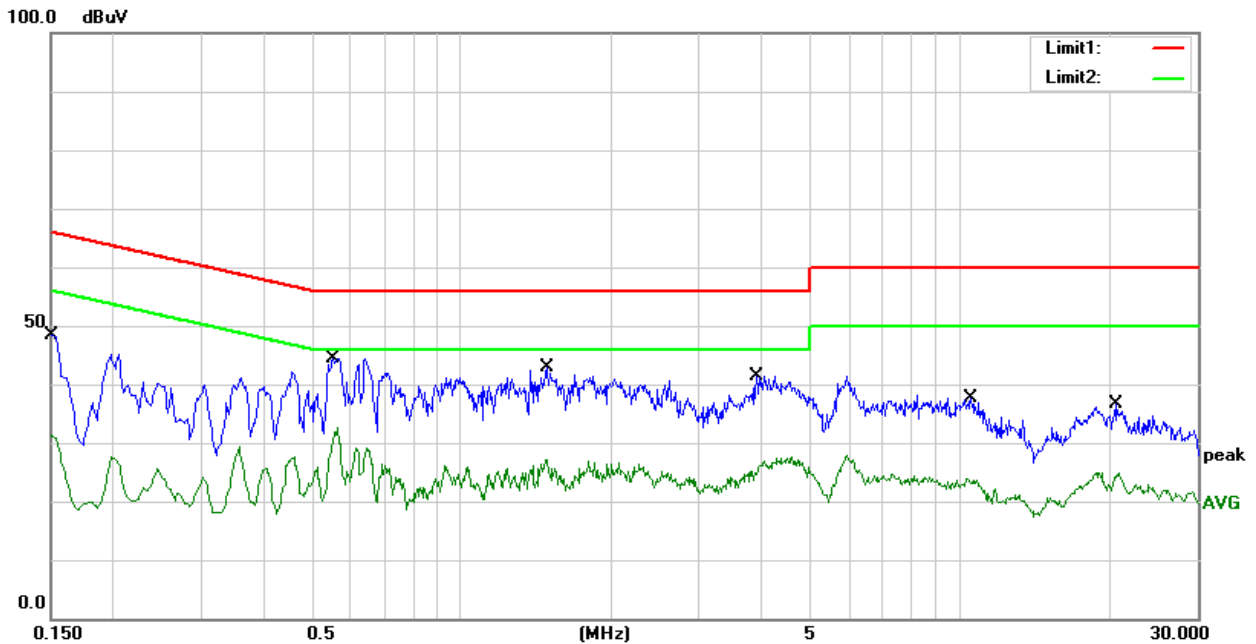

### 3.2 RADIATED EMISSION AND ( BANDEDGE) MEASUREMENT

#### 3.2.1 RADIATED EMISSION LIMITS (Frequency Range 9kHz-1000MHz)

In case the emission fall within the restricted band specified on 15.407(b)7& 15.205/209(a), then the limit in the table below has to be followed.

Frequencies (MHz)	Field Strength (microrvolts/meter)	Measurement Distance (meters)
0.009~0.490	2400/F(KHz)	300
0.490~1.705	24000/F(KHz)	30
1.705~30.0	30	30
30~88	100	3
88~216	150	3
216~960	200	3
Above 960	500	3

#### LIMITS OF RADIATED EMISSION MEASUREMENT (Above 1000MHz)

FREQUENCY (MHz)	Class B (dBuV/m) (at 3M)	
	PEAK	AVERAGE
Above 1000	68.2	54

Notes:

- (1) The limit for radiated test was performed according to FCC PART 15E.
- (2) The tighter limit applies at the band edges.
- (3) Emission level (dBuV/m)=20log Emission level (uV/m).

#### LIMITS OF RESTRICTED FREQUENCY BANDS

FREQUENCY (MHz)	FREQUENCY (MHz)	FREQUENCY (MHz)	FREQUENCY (GHz)
0.090-0.110	16.42-16.423	399.9-410	4.5-5.15
0.495-0.505	16.69475-16.69525	608-614	5.35-5.46
2.1735-2.1905	16.80425-16.80475	960-1240	7.25-7.75
4.125-4.128	25.5-25.67	1300-1427	8.025-8.5
4.17725-4.17775	37.5-38.25	1435-1626.5	9.0-9.2
4.20725-4.20775	73-74.6	1645.5-1646.5	9.3-9.5
6.215-6.218	74.8-75.2	1660-1710	10.6-12.7
6.26775-6.26825	108-121.94	1718.8-1722.2	13.25-13.4
6.31175-6.31225	123-138	2200-2300	14.47-14.5
8.291-8.294	149.9-150.05	2310-2390	15.35-16.2
8.362-8.366	156.52475-156.52525	2483.5-2500	17.7-21.4
8.37625-8.38675	156.7-156.9	2690-2900	22.01-23.12
8.41425-8.41475	162.0125-167.17	3260-3267	23.6-24.0
12.29-12.293	167.72-173.2	3332-3339	31.2-31.8
12.51975-12.52025	240-285	3345.8-3358	36.43-36.5
12.57675-12.57725	322-335.4	3600-4400	Above 38.6
13.36-13.41			

Note: In case the emission radiated emission above 1000MHz fall within the restricted band the restricted frequency bands, the peak limit is 74 dBuV/m.



LIMITS OF EMISSIONS OUTSIDE OF THE FREQUENCY BANDS

Undesirable emission limits. Except as shown in paragraph (b)(7) of this section, the maximum emissions outside of the frequency bands of operation shall be attenuated in accordance with the following limits:

- (1) For transmitters operating in the 5.15-5.25 GHz band: All emissions outside of the 5.15-5.35 GHz band shall not exceed an e.i.r.p. of -27 dBm/MHz.
- (2) For transmitters operating in the 5.25-5.35 GHz band: All emissions outside of the 5.15-5.35 GHz band shall not exceed an e.i.r.p. of -27 dBm/MHz.
- (3) For transmitters operating in the 5.47-5.725 GHz band: All emissions outside of the 5.47-5.725 GHz band shall not exceed an e.i.r.p. of -27 dBm/MHz.
- (4) For transmitters operating in the 5.725-5.85 GHz band:
  - (i) All emissions shall be limited to a level of -27 dBm/MHz at 75 MHz or more above or below the band edge increasing linearly to 10 dBm/MHz at 25 MHz above or below the band edge, and from 25 MHz above or below the band edge increasing linearly to a level of 15.6 dBm/MHz at 5 MHz above or below the band edge, and from 5 MHz above or below the band edge increasing linearly to a level of 27 dBm/MHz at the band edge.

Note: dBuV/m(at 3M) = EIRP(dBm) + 95.3.

Peak Limit = -27dBm/MHz + 95.3 = 68.3 dBuV/m.

Spectrum Parameter	Setting
Attenuation	Auto
Detector	Peak
Start Frequency	1000 MHz(Peak/AV)
Stop Frequency	10th carrier harmonic (Peak/AV)
RB / VB (emission in restricted band)	1 MHz / 1 MHz, AV=1 MHz /3 MHz

For Band edge

Spectrum Parameter	Setting
Detector	Peak
RB / VB (emission in restricted band)	1 MHz / 1 MHz, AV=1 MHz /3 MHz

Receiver Parameter	Setting
Attenuation	Auto
Start ~ Stop Frequency	9kHz~90kHz / RB 200Hz for PK & AV
Start ~ Stop Frequency	90kHz~110kHz / RB 200Hz for QP
Start ~ Stop Frequency	110kHz~490kHz / RB 200Hz for PK & AV
Start ~ Stop Frequency	490kHz~30MHz / RB 9kHz for QP
Start ~ Stop Frequency	30MHz~1000MHz / RB 120kHz for QP



### 3.2.2 TEST PROCEDURE

- a. The measuring distance at 3 m shall be used for measurements at frequency 0.009MHz up to 1GHz, and above 1GHz.
- b. The EUT was placed on the top of a rotating table 0.8 m (above 1GHz is 1.5 m) above the ground at a 3 m anechoic chamber test site. The table was rotated 360 degree to determine the position of the highest radiation.
- c. The height of the equipment shall be 0.8 m (above 1GHz is 1.5 m); the height of the test antenna shall vary between 1 m to 4 m. Horizontal and vertical polarization of the antenna are set to make the measurement.
- d. The initial step in collecting conducted emission data is a spectrum analyzer peak detector mode pre-scanning the measurement frequency range. Significant peaks are then marked and QuasiPeak detector mode will be re-measured.
- e. If the Peak Mode measured value is compliance with and lower than Quasi Peak Mode Limit, the EUT shall be deemed to meet QP Limits and no additional QP Mode measurement was performed.
- f. For the actual test configuration, please refer to the related Item –EUT Test Photos.

Note:

Both horizontal and vertical antenna polarities were tested and performed pretest to three orthogonal axis. The worst case emissions were reported.

### 3.2.2 DEVIATION FROM TEST STANDARD

No deviation



### 3.2.3 TEST SETUP

(A) Radiated Emission Test-Up Frequency Below 30MHz

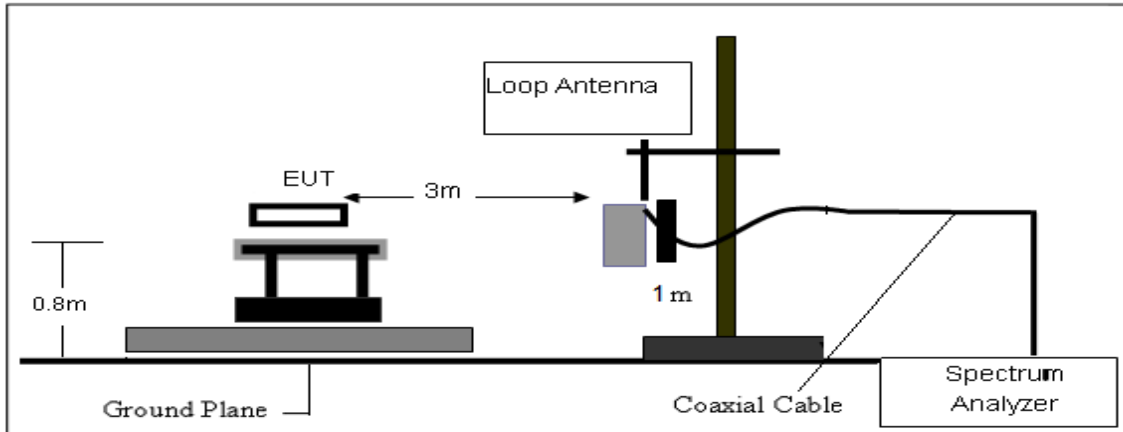

(B) Radiated Emission Test-Up Frequency 30MHz~1GHz

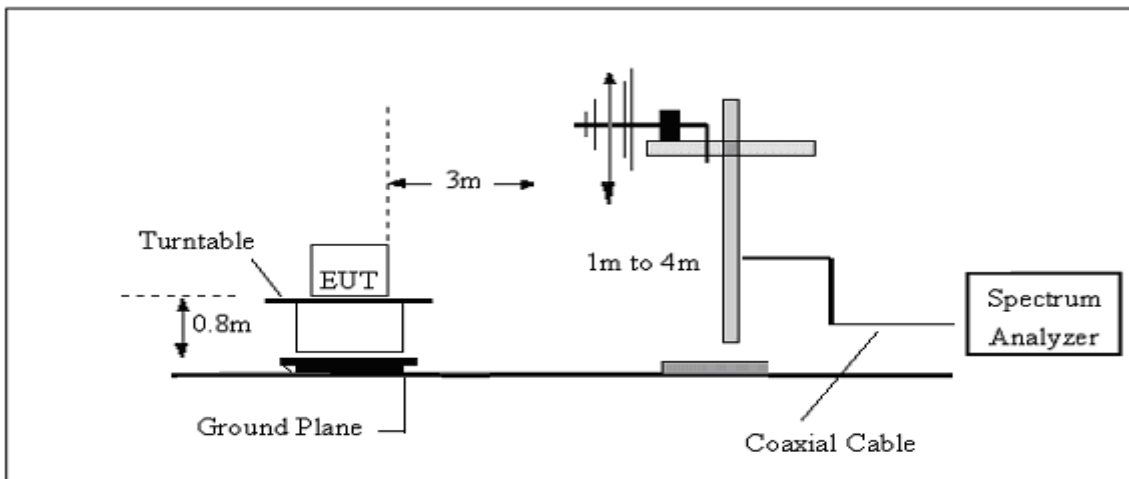

(C) Radiated Emission Test-Up Frequency Above 1GHz

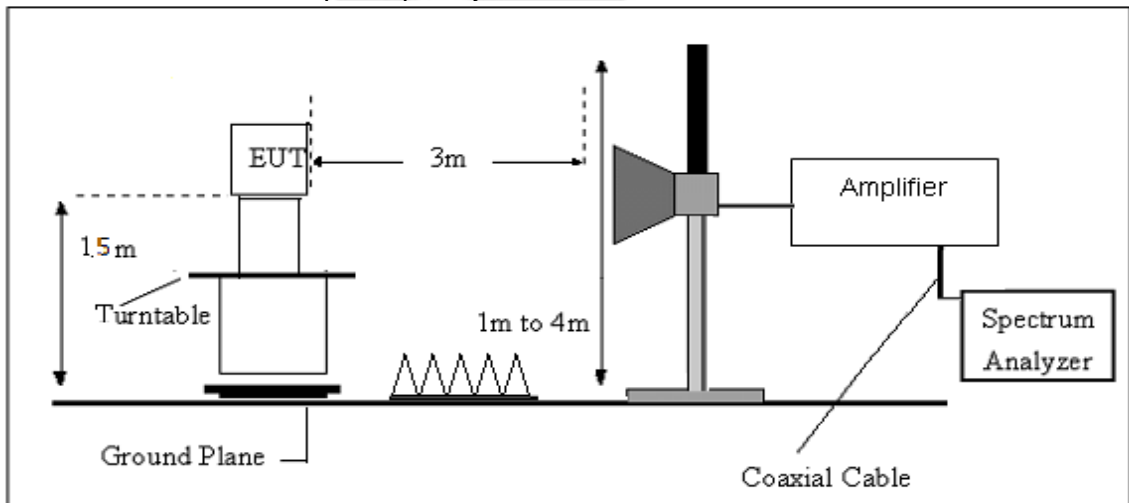



### 3.2.4 EUT OPERATING CONDITIONS

The EUT tested system was configured as the statements of 2.4 Unless otherwise a special operating condition is specified in the follows during the testing.

### 3.2.5 FIELD STRENGTH CALCULATION

The field strength is calculated by adding the Antenna Factor and Cable Factor and subtracting the Amplifier Gain and Duty Cycle Correction Factor (if any) from the measured reading. The basic equation with a sample calculation is as follows:

$$FS = RA + AF + CL - AG$$

Where

FS = Field Strength

CL = Cable Attenuation Factor (Cable Loss)

RA = Reading Amplitude

AG = Amplifier Gain

AF = Antenna Factor

For example

Frequency (MHz)	FS (dB $\mu$ V/m)	RA (dB $\mu$ V/m)	AF (dB)	CL (dB)	AG (dB)	Factor (dB)
300	40	58.1	12.2	1.6	31.9	-18.1

$$\text{Factor} = \text{AF} + \text{CL} - \text{AG}$$

**3.2.6 TEST RESULTS (Between 9KHz – 30 MHz)**

Temperature:	23.1(C)	Relative Humidity:	60%RH
Test Voltage:	DC 3.8V	Polarization :	--
Test Mode:	TX Mode		

Freq. (MHz)	Reading (dBuV/m)	Limit (dBuV/m)	Margin (dB)	State P/F
--	--	--	--	PASS
--	--	--	--	PASS

**Note:**

The amplitude of spurious emissions which are attenuated by more than 20dB below the permissible value has no need to be reported.

Distance extrapolation factor =  $40 \log(\text{specific distance}/\text{test distance})$ (dB);

Limit line = specific limits(dBuv) + distance extrapolation factor.

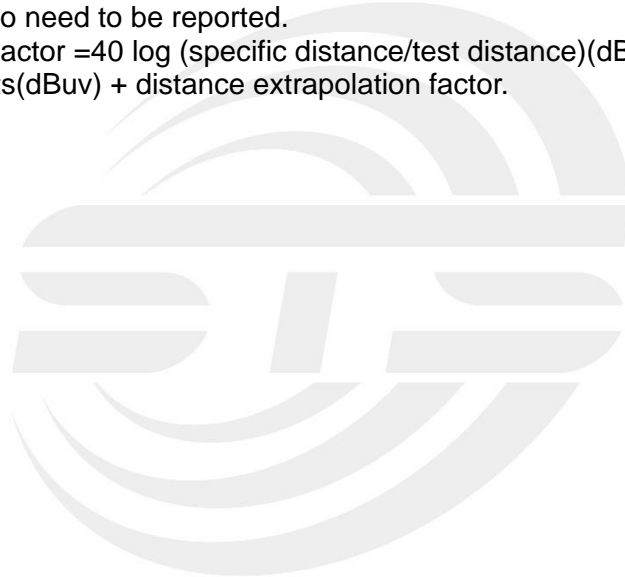





3.2.7 TEST RESULTS (Between 30MHz – 1GHz)

Temperature	23.1(C)	Relative Humidity:	60%RH
Test Voltage	DC 3.8V	Polarization:	Horizontal
Test Mode	Mode 1~12(Mode 2 worst mode)		

No.	Frequency (MHz)	Reading (dBuV)	Correct Factor(dB/m)	Result (dBuV/m)	Limit (dBuV/m)	Margin (dB)	Remark
1	33.8800	26.94	-14.80	12.14	40.00	-27.86	QP
2	348.1600	33.95	-13.13	20.82	46.00	-25.18	QP
3	578.0500	27.94	-5.73	22.21	46.00	-23.79	QP
4	733.2500	28.37	-2.35	26.02	46.00	-19.98	QP
5	914.6400	28.16	-0.10	28.06	46.00	-17.94	QP
6	978.6600	27.55	2.58	30.13	54.00	-23.87	QP

Remark:

1. Margin = Result (Result =Reading + Factor )-Limit
2. Factor= Antenna factor+Cable attenuation factor(cable loss)-Amplifier gain

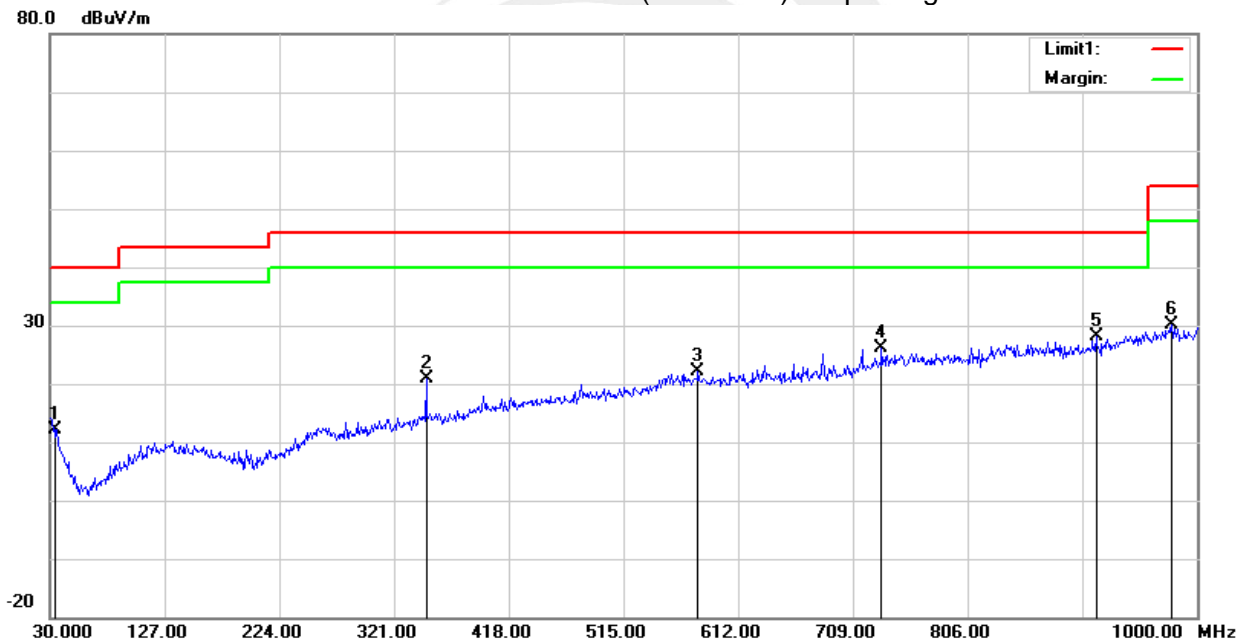



Temperature	23.1(C)	Relative Humidity:	60%RH
Test Voltage	DC 3.8V	Polarization:	Vertical
Test Mode	Mode 1~12(Mode 2 worst mode)		

No.	Frequency (MHz)	Reading (dBuV)	Correct Factor(dB/m)	Result (dBuV/m)	Limit (dBuV/m)	Margin (dB)	Remark
1	36.7900	28.24	-16.39	11.85	40.00	-28.15	QP
2	177.4400	31.23	-20.03	11.20	43.50	-32.30	QP
3	419.9400	29.50	-10.09	19.41	46.00	-26.59	QP
4	557.6800	27.87	-5.55	22.32	46.00	-23.68	QP
5	733.2500	27.42	-2.35	25.07	46.00	-20.93	QP
6	978.6600	26.67	2.58	29.25	54.00	-24.75	QP

Remark:

- Margin = Result (Result =Reading + Factor) –Limit
- Factor= Antenna factor+Cable attenuation factor(cable loss)-Amplifier gain

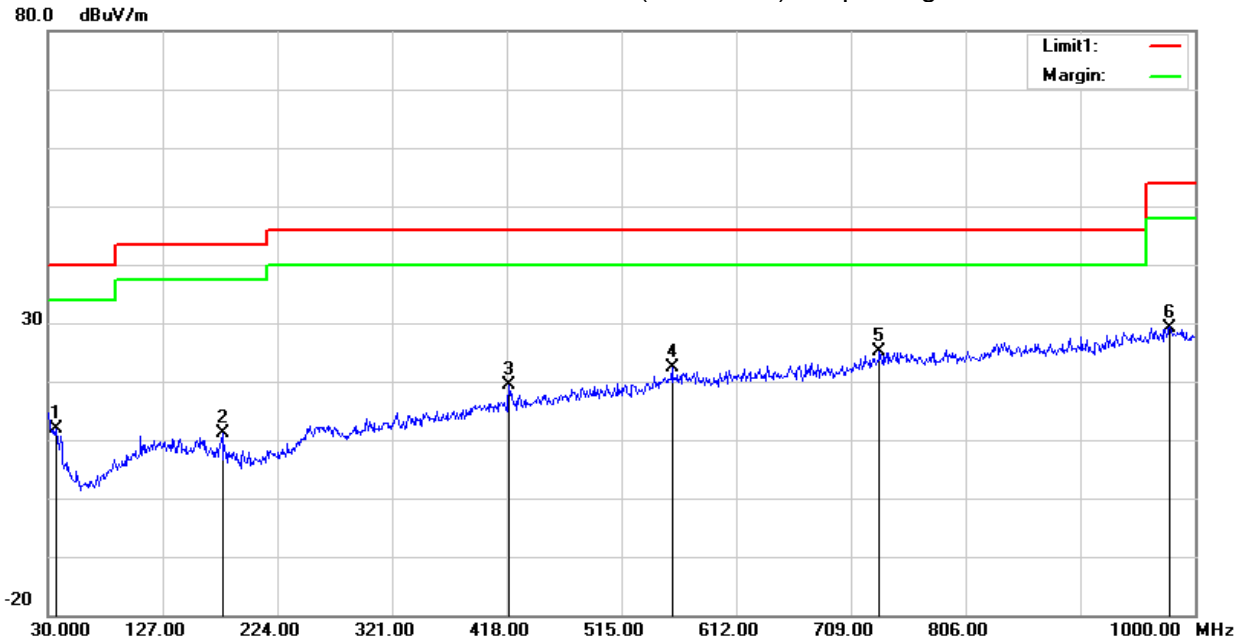



3.2.8 TEST RESULTS (Above 1000 MHz)

Band I 5150-5250MHz

Frequency (MHz)	Reading (dBuV)	Amplifier (dB)	Loss (dB)	Antenna Factor (dB/m)	Orrected Factor (dB)	Emission Level (dBuV/m)	Limit (dBuV/m)	Margin (dB)	Detector	Comment
Low Channel (802.11a/ 5180 MHz)										
3251.42	44.14	44.70	6.70	28.20	-9.80	34.34	68.20	-33.86	Pk	Vertical
3251.42	41.71	44.70	6.70	28.20	-9.80	31.91	54.00	-22.09	AV	Vertical
3254.66	44.30	44.70	6.70	28.20	-9.80	34.50	68.20	-33.70	Pk	Horizontal
3254.66	40.86	44.70	6.70	28.20	-9.80	31.06	54.00	-22.94	AV	Horizontal
3996.94	39.08	44.20	7.90	29.70	-6.60	32.48	68.20	-35.72	Pk	Vertical
3996.94	36.97	44.20	7.90	29.70	-6.60	30.37	54.00	-23.63	AV	Vertical
3985.23	39.00	44.20	7.90	29.70	-6.60	32.40	68.20	-35.80	Pk	Horizontal
3985.23	36.25	44.20	7.90	29.70	-6.60	29.65	54.00	-24.35	AV	Horizontal
7231.85	37.77	43.50	11.40	35.50	3.40	41.17	68.20	-27.03	Pk	Vertical
7231.85	33.70	43.50	11.40	35.50	3.40	37.10	54.00	-16.90	AV	Vertical
7228.07	36.78	43.50	11.40	35.50	3.40	40.18	68.20	-28.02	Pk	Horizontal
7228.07	34.70	43.50	11.40	35.50	3.40	38.10	54.00	-15.90	AV	Horizontal
10360.26	38.90	44.50	13.80	38.80	8.10	47.00	68.20	-21.20	Pk	Vertical
10360.26	35.83	44.50	13.80	38.80	8.10	43.93	54.00	-10.07	AV	Vertical
10360.30	39.71	44.50	13.80	38.80	8.10	47.81	68.20	-20.39	Pk	Horizontal
10360.30	35.82	44.50	13.80	38.80	8.10	43.92	54.00	-10.08	AV	Horizontal
11022.63	33.03	43.60	14.30	39.50	10.20	43.23	68.20	-24.97	Pk	Vertical
11022.63	30.53	43.60	14.30	39.50	10.20	40.73	54.00	-13.27	AV	Vertical
11023.11	32.81	43.60	14.30	39.50	10.20	43.01	68.20	-25.19	Pk	Horizontal
11023.11	30.25	43.60	14.30	39.50	10.20	40.45	54.00	-13.55	AV	Horizontal
13290.36	32.59	42.60	15.90	38.90	12.20	44.79	68.20	-23.41	Pk	Vertical
13290.36	28.55	42.60	15.90	38.90	12.20	40.75	54.00	-13.25	AV	Vertical
13297.20	32.62	42.60	15.90	38.90	12.20	44.82	68.20	-23.38	Pk	Horizontal
13297.20	29.66	42.60	15.90	38.90	12.20	41.86	54.00	-12.14	AV	Horizontal
Mid Channel (802.11a/ 5200 MHz)										
3254.95	44.09	44.70	6.70	28.20	-9.80	34.29	68.20	-33.91	Pk	Vertical
3254.95	41.44	44.70	6.70	28.20	-9.80	31.64	54.00	-22.36	AV	Vertical
3249.37	45.24	44.70	6.70	28.20	-9.80	35.44	68.20	-32.76	Pk	Horizontal
3249.37	41.19	44.70	6.70	28.20	-9.80	31.39	54.00	-22.61	AV	Horizontal
3980.55	39.40	44.20	7.90	29.70	-6.60	32.80	68.20	-35.40	Pk	Vertical
3980.55	35.87	44.20	7.90	29.70	-6.60	29.27	54.00	-24.73	AV	Vertical
3982.42	38.79	44.20	7.90	29.70	-6.60	32.19	68.20	-36.01	Pk	Horizontal
3982.42	36.89	44.20	7.90	29.70	-6.60	30.29	54.00	-23.71	AV	Horizontal
7224.10	37.69	43.50	11.40	35.50	3.40	41.09	68.20	-27.11	Pk	Vertical
7224.10	33.77	43.50	11.40	35.50	3.40	37.17	54.00	-16.83	AV	Vertical
7235.90	37.09	43.50	11.40	35.50	3.40	40.49	68.20	-27.71	Pk	Horizontal
7235.90	34.73	43.50	11.40	35.50	3.40	38.13	54.00	-15.87	AV	Horizontal
10400.36	39.56	44.50	13.80	38.80	8.10	47.66	68.20	-20.54	Pk	Vertical
10400.36	36.18	44.50	13.80	38.80	8.10	44.28	54.00	-9.72	AV	Vertical
10400.30	39.11	44.50	13.80	38.80	8.10	47.21	68.20	-20.99	Pk	Horizontal
10400.30	36.57	44.50	13.80	38.80	8.10	44.67	54.00	-9.33	AV	Horizontal
11032.71	32.86	43.60	14.30	39.50	10.20	43.06	68.20	-25.14	Pk	Vertical
11032.71	30.88	43.60	14.30	39.50	10.20	41.08	54.00	-12.92	AV	Vertical
11017.97	33.30	43.60	14.30	39.50	10.20	43.50	68.20	-24.70	Pk	Horizontal
11017.97	30.83	43.60	14.30	39.50	10.20	41.03	54.00	-12.97	AV	Horizontal
13297.01	31.69	42.60	15.90	38.90	12.20	43.89	68.20	-24.31	Pk	Vertical
13297.01	29.73	42.60	15.90	38.90	12.20	41.93	54.00	-12.07	AV	Vertical
13291.23	31.88	42.60	15.90	38.90	12.20	44.08	68.20	-24.12	Pk	Horizontal
13291.23	29.18	42.60	15.90	38.90	12.20	41.38	54.00	-12.62	AV	Horizontal



High Channel (802.11a/ 5240 MHz)										
3251.78	44.43	44.70	6.70	28.20	-9.80	34.63	68.20	-33.57	Pk	Vertical
3251.78	40.75	44.70	6.70	28.20	-9.80	30.95	54.00	-23.05	AV	Vertical
3260.37	44.65	44.70	6.70	28.20	-9.80	34.85	68.20	-33.35	Pk	Horizontal
3260.37	42.12	44.70	6.70	28.20	-9.80	32.32	54.00	-21.68	AV	Horizontal
3980.32	40.07	44.20	7.90	29.70	-6.60	33.47	68.20	-34.73	Pk	Vertical
3980.32	36.37	44.20	7.90	29.70	-6.60	29.77	54.00	-24.23	AV	Vertical
3986.00	38.83	44.20	7.90	29.70	-6.60	32.23	68.20	-35.97	Pk	Horizontal
3986.00	36.34	44.20	7.90	29.70	-6.60	29.74	54.00	-24.26	AV	Horizontal
7227.82	37.41	43.50	11.40	35.50	3.40	40.81	68.20	-27.39	Pk	Vertical
7227.82	33.47	43.50	11.40	35.50	3.40	36.87	54.00	-17.13	AV	Vertical
7225.38	37.14	43.50	11.40	35.50	3.40	40.54	68.20	-27.66	Pk	Horizontal
7225.38	34.01	43.50	11.40	35.50	3.40	37.41	54.00	-16.59	AV	Horizontal
10480.06	39.04	44.50	13.80	38.80	8.10	47.14	68.20	-21.06	Pk	Vertical
10480.06	36.53	44.50	13.80	38.80	8.10	44.63	54.00	-9.37	AV	Vertical
10479.97	40.13	44.50	13.80	38.80	8.10	48.23	68.20	-19.97	Pk	Horizontal
10479.97	36.16	44.50	13.80	38.80	8.10	44.26	54.00	-9.74	AV	Horizontal
11025.42	33.61	43.60	14.30	39.50	10.20	43.81	68.20	-24.39	Pk	Vertical
11025.42	31.00	43.60	14.30	39.50	10.20	41.20	54.00	-12.80	AV	Vertical
11032.01	33.91	43.60	14.30	39.50	10.20	44.11	68.20	-24.09	Pk	Horizontal
11032.01	29.69	43.60	14.30	39.50	10.20	39.89	54.00	-14.11	AV	Horizontal
13291.84	32.61	42.60	15.90	38.90	12.20	44.81	68.20	-23.39	Pk	Vertical
13291.84	29.79	42.60	15.90	38.90	12.20	41.99	54.00	-12.01	AV	Vertical
13299.93	32.89	42.60	15.90	38.90	12.20	45.09	68.20	-23.11	Pk	Horizontal
13299.93	29.78	42.60	15.90	38.90	12.20	41.98	54.00	-12.02	AV	Horizontal

## Remark:

- Factor = Antenna Factor + Cable Loss – Pre-amplifier.
- Scan with 802.11a,802.11n (HT-20),802.11n (HT-40), 802.11ac (VHT-20),802.11ac (VHT-40), 802.11ac (VHT-80) the worst case is 802.11a.
- The frequency emission of peak points that did not show above the forms are at least 20dB below the limit, the frequency emission is mainly from the environment noise.



**Band IV(5.725-5.850) GHz**

Frequency (MHz)	Reading	Amplifier	Loss	Antenna Factor	Orrected Factor	Emission Level	Limit (dBuV/m)	Margin	Detector	Comment
	(dBuV)	(dB)	(dB)	(dB/m)	(dB)	(dBuV/m)		(dB)		
Low Channel (802.11a/ 5745 MHz)										
3257.80	44.96	44.70	6.70	28.20	-9.80	35.16	68.20	-33.04	Pk	Vertical
3257.80	41.53	44.70	6.70	28.20	-9.80	31.73	54.00	-22.27	AV	Vertical
3257.82	44.43	44.70	6.70	28.20	-9.80	34.63	68.20	-33.57	Pk	Horizontal
3257.82	40.90	44.70	6.70	28.20	-9.80	31.10	54.00	-22.90	AV	Horizontal
3992.82	39.67	44.20	7.90	29.70	-6.60	33.07	68.20	-35.13	Pk	Vertical
3992.82	35.75	44.20	7.90	29.70	-6.60	29.15	54.00	-24.85	AV	Vertical
3984.46	39.87	44.20	7.90	29.70	-6.60	33.27	68.20	-34.93	Pk	Horizontal
3984.46	36.73	44.20	7.90	29.70	-6.60	30.13	54.00	-23.87	AV	Horizontal
7230.19	37.11	43.50	11.40	35.50	3.40	40.51	68.20	-27.69	Pk	Vertical
7230.19	34.19	43.50	11.40	35.50	3.40	37.59	54.00	-16.41	AV	Vertical
7227.51	36.76	43.50	11.40	35.50	3.40	40.16	68.20	-28.04	Pk	Horizontal
7227.51	33.90	43.50	11.40	35.50	3.40	37.30	54.00	-16.70	AV	Horizontal
10502.79	39.35	44.50	13.90	38.80	8.20	47.55	68.20	-20.65	Pk	Vertical
10502.79	36.60	44.50	13.90	38.80	8.20	44.80	54.00	-9.20	AV	Vertical
10504.94	38.79	44.50	13.90	38.80	8.20	46.99	68.20	-21.21	Pk	Horizontal
10504.94	36.09	44.50	13.90	38.80	8.20	44.29	54.00	-9.71	AV	Horizontal
11490.38	33.61	43.60	14.30	39.50	10.20	43.81	68.20	-24.39	Pk	Vertical
11490.38	31.02	43.60	14.30	39.50	10.20	41.22	54.00	-12.78	AV	Vertical
11489.99	33.56	43.60	14.30	39.50	10.20	43.76	68.20	-24.44	Pk	Horizontal
11489.99	30.55	43.60	14.30	39.50	10.20	40.75	54.00	-13.25	AV	Horizontal
13286.60	32.16	42.60	15.90	38.90	12.20	44.36	68.20	-23.84	Pk	Vertical
13286.60	29.00	42.60	15.90	38.90	12.20	41.20	54.00	-12.80	AV	Vertical
13296.13	31.78	42.60	15.90	38.90	12.20	43.98	68.20	-24.22	Pk	Horizontal
13296.13	28.76	42.60	15.90	38.90	12.20	40.96	54.00	-13.04	AV	Horizontal
Mid Channel (802.11a/ 5785 MHz)										
3264.64	43.86	44.70	6.70	28.20	-9.80	34.06	68.20	-34.14	Pk	Vertical
3264.64	42.08	44.70	6.70	28.20	-9.80	32.28	54.00	-21.72	AV	Vertical
3246.74	44.32	44.70	6.70	28.20	-9.80	34.52	68.20	-33.68	Pk	Horizontal
3246.74	42.04	44.70	6.70	28.20	-9.80	32.24	54.00	-21.76	AV	Horizontal
3996.71	39.16	44.20	7.90	29.70	-6.60	32.56	68.20	-35.64	Pk	Vertical
3996.71	35.84	44.20	7.90	29.70	-6.60	29.24	54.00	-24.76	AV	Vertical
3987.55	39.50	44.20	7.90	29.70	-6.60	32.90	68.20	-35.30	Pk	Horizontal
3987.55	36.04	44.20	7.90	29.70	-6.60	29.44	54.00	-24.56	AV	Horizontal
7227.52	37.63	43.50	11.40	35.50	3.40	41.03	68.20	-27.17	Pk	Vertical
7227.52	34.62	43.50	11.40	35.50	3.40	38.02	54.00	-15.98	AV	Vertical
7230.14	36.58	43.50	11.40	35.50	3.40	39.98	68.20	-28.22	Pk	Horizontal
7230.14	34.07	43.50	11.40	35.50	3.40	37.47	54.00	-16.53	AV	Horizontal
10582.14	38.91	44.50	13.80	38.80	8.10	47.01	68.20	-21.19	Pk	Vertical
10582.14	36.67	44.50	13.80	38.80	8.10	44.77	54.00	-9.23	AV	Vertical
10598.78	39.12	44.50	13.80	38.80	8.10	47.22	68.20	-20.98	Pk	Horizontal
10598.78	35.67	44.50	13.80	38.80	8.10	43.77	54.00	-10.23	AV	Horizontal
11570.36	33.68	43.60	14.30	39.50	10.20	43.88	68.20	-24.32	Pk	Vertical
11570.36	29.80	43.60	14.30	39.50	10.20	40.00	54.00	-14.00	AV	Vertical
11570.23	33.44	43.60	14.30	39.50	10.20	43.64	68.20	-24.56	Pk	Horizontal
11570.23	30.68	43.60	14.30	39.50	10.20	40.88	54.00	-13.12	AV	Horizontal
13298.24	32.22	42.60	15.90	38.90	12.20	44.42	68.20	-23.78	Pk	Vertical
13298.24	29.48	42.60	15.90	38.90	12.20	41.68	54.00	-12.32	AV	Vertical
13283.87	31.72	42.60	15.90	38.90	12.20	43.92	68.20	-24.28	Pk	Horizontal
13283.87	29.46	42.60	15.90	38.90	12.20	41.66	54.00	-12.34	AV	Horizontal



High Channel (802.11a/ 5825 MHz)										
3260.62	44.00	44.70	6.70	28.20	-9.80	34.20	68.20	-34.00	Pk	Vertical
3260.62	41.06	44.70	6.70	28.20	-9.80	31.26	54.00	-22.74	AV	Vertical
3250.13	45.11	44.70	6.70	28.20	-9.80	35.31	68.20	-32.89	Pk	Horizontal
3250.13	41.47	44.70	6.70	28.20	-9.80	31.67	54.00	-22.33	AV	Horizontal
3998.85	39.25	44.20	7.90	29.70	-6.60	32.65	68.20	-35.55	Pk	Vertical
3998.85	35.90	44.20	7.90	29.70	-6.60	29.30	54.00	-24.70	AV	Vertical
3980.62	39.05	44.20	7.90	29.70	-6.60	32.45	68.20	-35.75	Pk	Horizontal
3980.62	36.31	44.20	7.90	29.70	-6.60	29.71	54.00	-24.29	AV	Horizontal
7223.83	37.46	43.50	11.40	35.50	3.40	40.86	68.20	-27.34	Pk	Vertical
7223.83	34.70	43.50	11.40	35.50	3.40	38.10	54.00	-15.90	AV	Vertical
7219.60	37.15	43.50	11.40	35.50	3.40	40.55	68.20	-27.65	Pk	Horizontal
7219.60	33.75	43.50	11.40	35.50	3.40	37.15	54.00	-16.85	AV	Horizontal
10625.96	39.66	44.50	13.80	38.80	8.10	47.76	68.20	-20.44	Pk	Vertical
10625.96	36.84	44.50	13.80	38.80	8.10	44.94	54.00	-9.06	AV	Vertical
10640.39	39.35	44.50	13.80	38.80	8.10	47.45	68.20	-20.75	Pk	Horizontal
10640.39	36.55	44.50	13.80	38.80	8.10	44.65	54.00	-9.35	AV	Horizontal
11650.11	34.06	43.60	14.30	39.50	10.20	44.26	68.20	-23.94	Pk	Vertical
11650.11	30.80	43.60	14.30	39.50	10.20	41.00	54.00	-13.00	AV	Vertical
11650.04	33.25	43.60	14.30	39.50	10.20	43.45	68.20	-24.75	Pk	Horizontal
11650.04	29.91	43.60	14.30	39.50	10.20	40.11	54.00	-13.89	AV	Horizontal
13295.07	31.56	42.70	18.00	37.10	12.40	43.96	68.20	-24.24	Pk	Vertical
13295.07	28.87	42.70	18.00	37.10	12.40	41.27	54.00	-12.73	AV	Vertical
13287.25	32.34	42.70	18.00	37.10	12.40	44.74	68.20	-23.46	Pk	Horizontal
13287.25	29.37	42.70	18.00	37.10	12.40	41.77	54.00	-12.23	AV	Horizontal

## Remark:

- Factor = Antenna Factor + Cable Loss – Pre-amplifier.
- Scan with 802.11a,802.11n (HT-20),802.11n (HT-40), 802.11ac (VHT-20),802.11ac (VHT-40), 802.11ac (VHT-80) the worst case is 802.11a.
- The frequency emission of peak points that did not show above the forms are at least 20dB below the limit, the frequency emission is mainly from the environment noise.



### 3.2.9 RESTRICTED FREQUENCY BANDS AND BAND EDGE

#### Band I 5150-5250MHz

802.11ac20-L-H

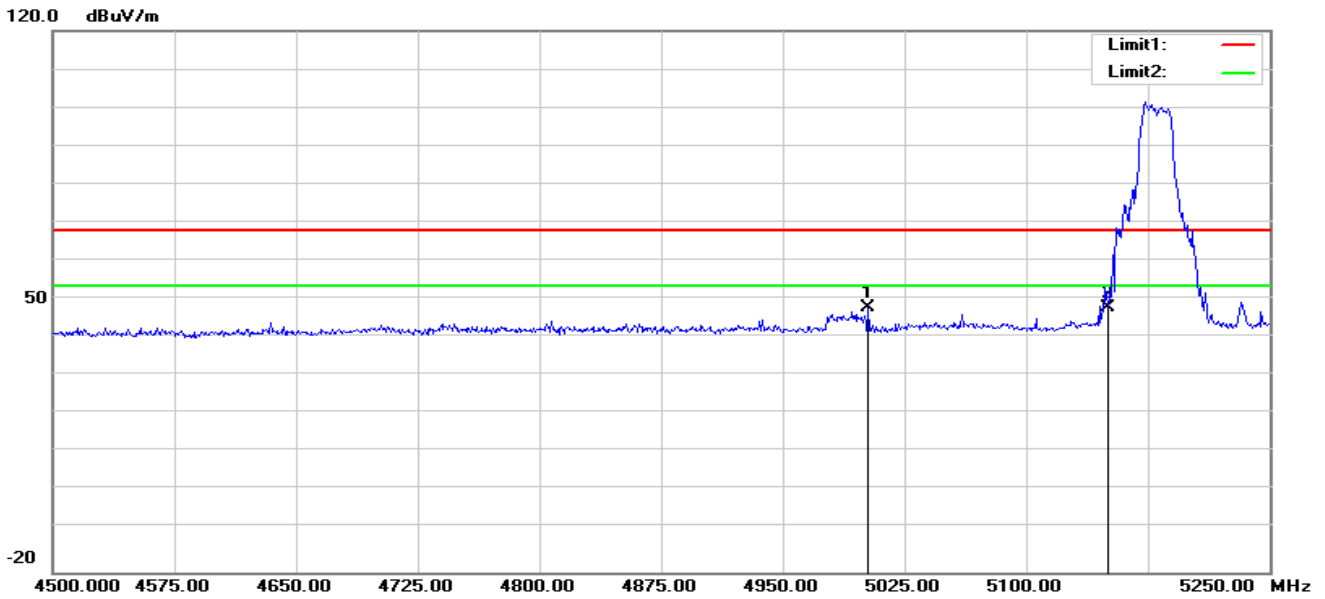

No.	Frequency (MHz)	Reading (dBuV)	Correct Factor(dB/m)	Result (dBuV/m)	Limit (dBuV/m)	Margin (dB)	Remark
1	5022.500	54.49	-6.18	48.31	68.20	-19.89	peak
2	5150.000	54.25	-5.73	48.52	68.20	-19.68	peak

802.11ac20-L-V

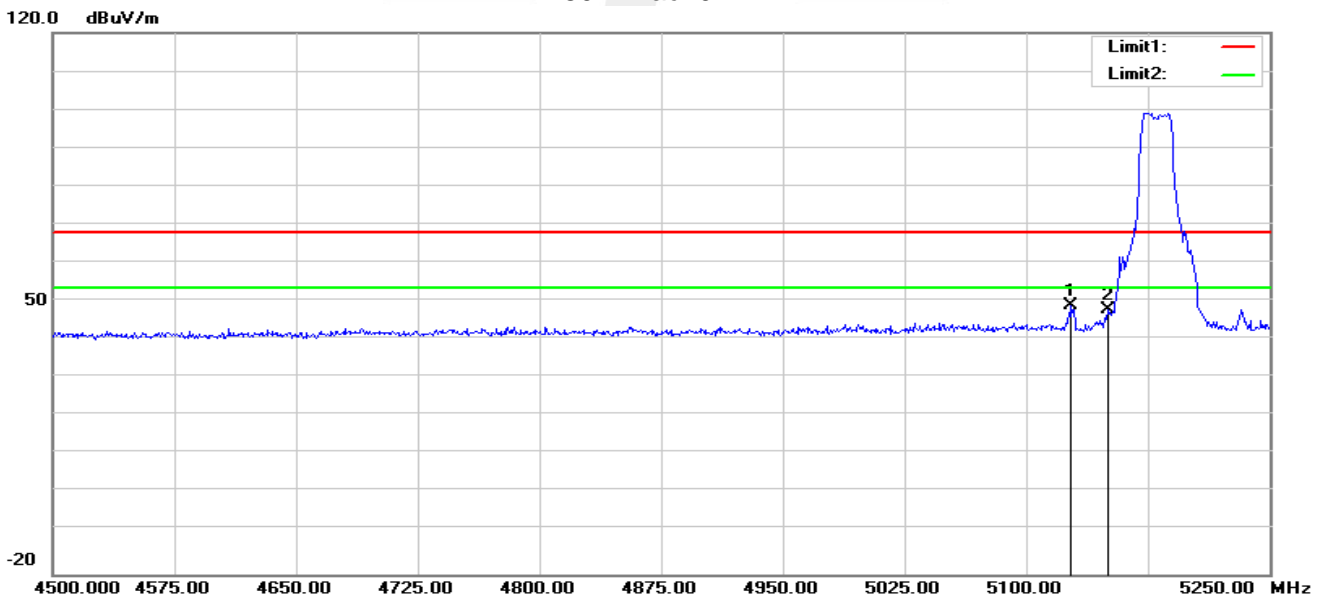

No.	Frequency (MHz)	Reading (dBuV)	Correct Factor(dB/m)	Result (dBuV/m)	Limit (dBuV/m)	Margin (dB)	Remark
1	5127.750	55.32	-5.74	49.58	68.20	-18.62	peak
2	5150.000	54.27	-5.73	48.54	68.20	-19.66	peak



802.11ac20-H-H

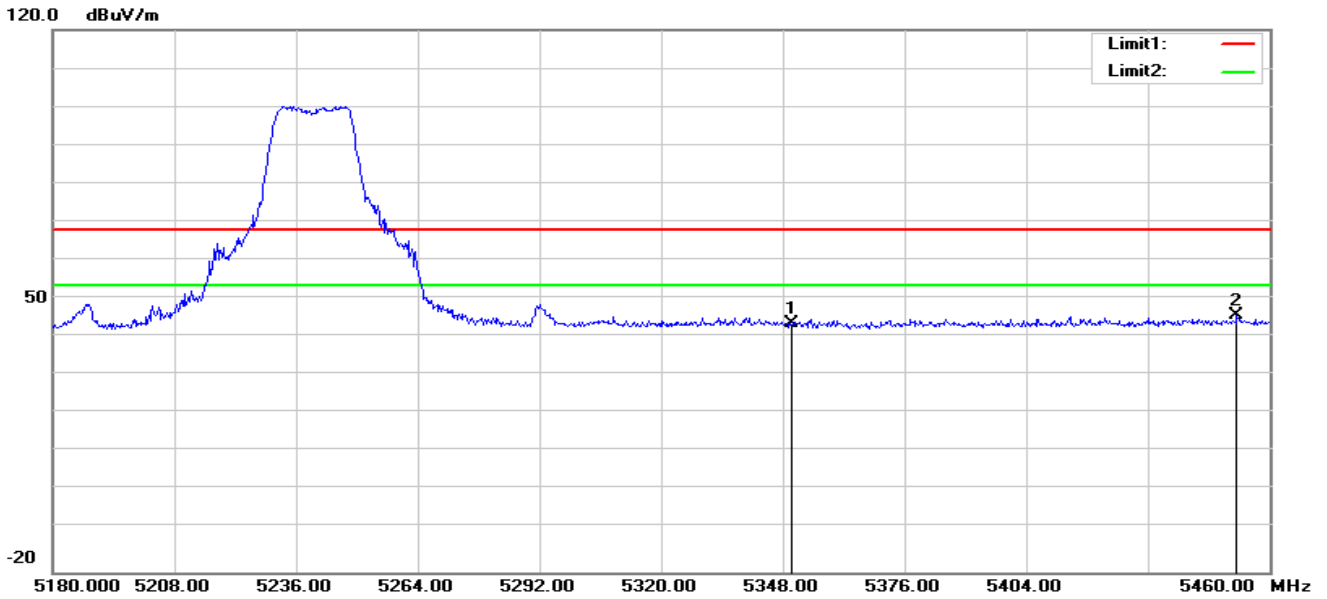

No.	Frequency (MHz)	Reading (dBuV)	Correct Factor(dB/m)	Result (dBuV/m)	Limit (dBuV/m)	Margin (dB)	Remark
1	5350.000	49.30	-5.23	44.07	68.20	-24.13	peak
2	5452.440	51.29	-5.13	46.16	68.20	-22.04	peak

802.11ac20-H-V

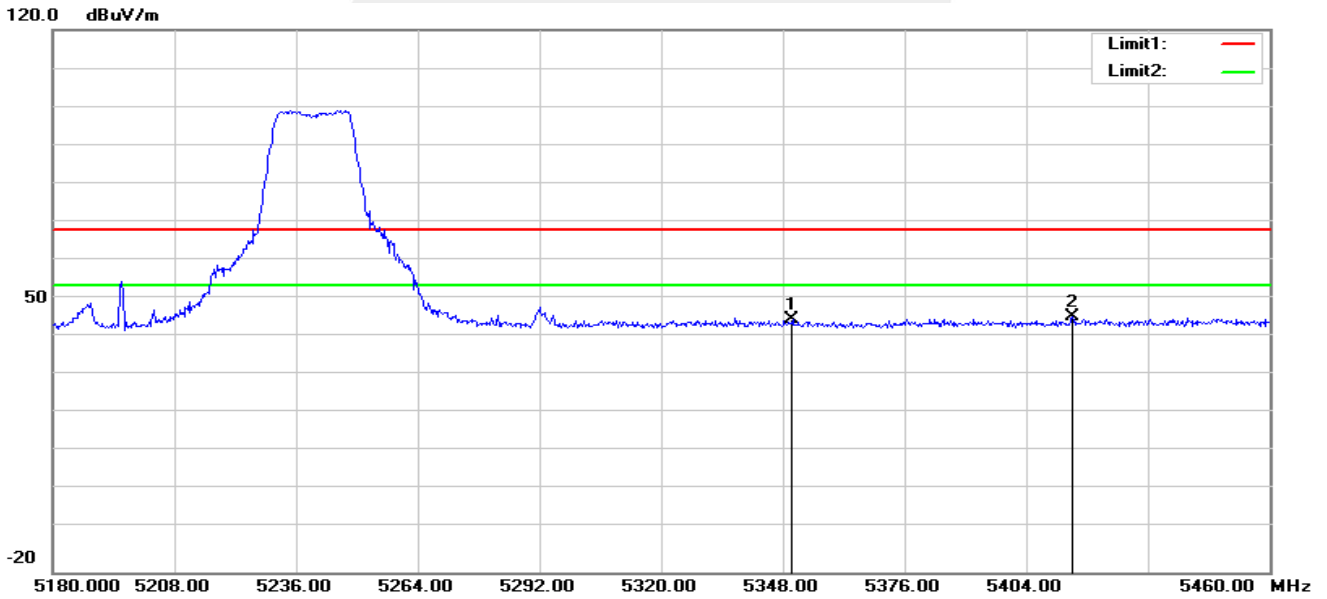

No.	Frequency (MHz)	Reading (dBuV)	Correct Factor(dB/m)	Result (dBuV/m)	Limit (dBuV/m)	Margin (dB)	Remark
1	5350.000	50.40	-5.23	45.17	68.20	-23.03	peak
2	5414.640	51.29	-5.22	46.07	68.20	-22.13	peak





802.11n40-L-H

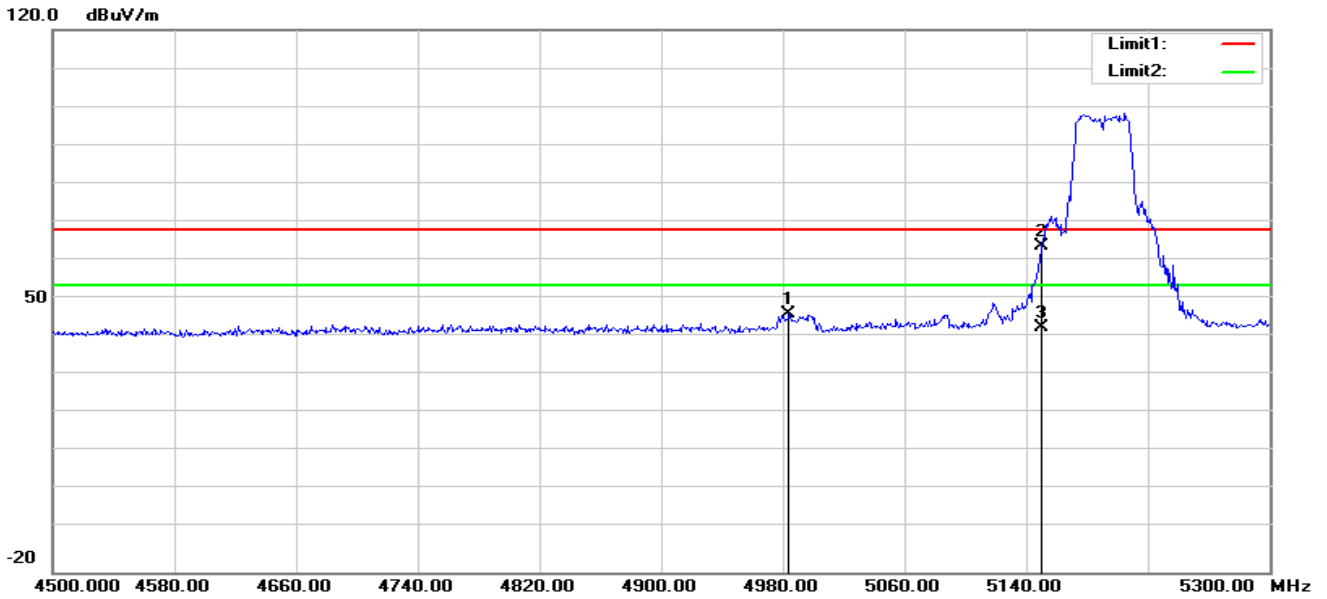

No.	Frequency (MHz)	Reading (dBuV)	Correct Factor(dB/m)	Result (dBuV/m)	Limit (dBuV/m)	Margin (dB)	Remark
1	4984.000	52.82	-6.29	46.53	68.20	-21.67	peak
2	5150.000	69.74	-5.73	64.01	68.20	-4.19	peak
3	5150.000	48.91	-5.73	43.18	54.00	-10.82	AVG

802.11n40-L-V

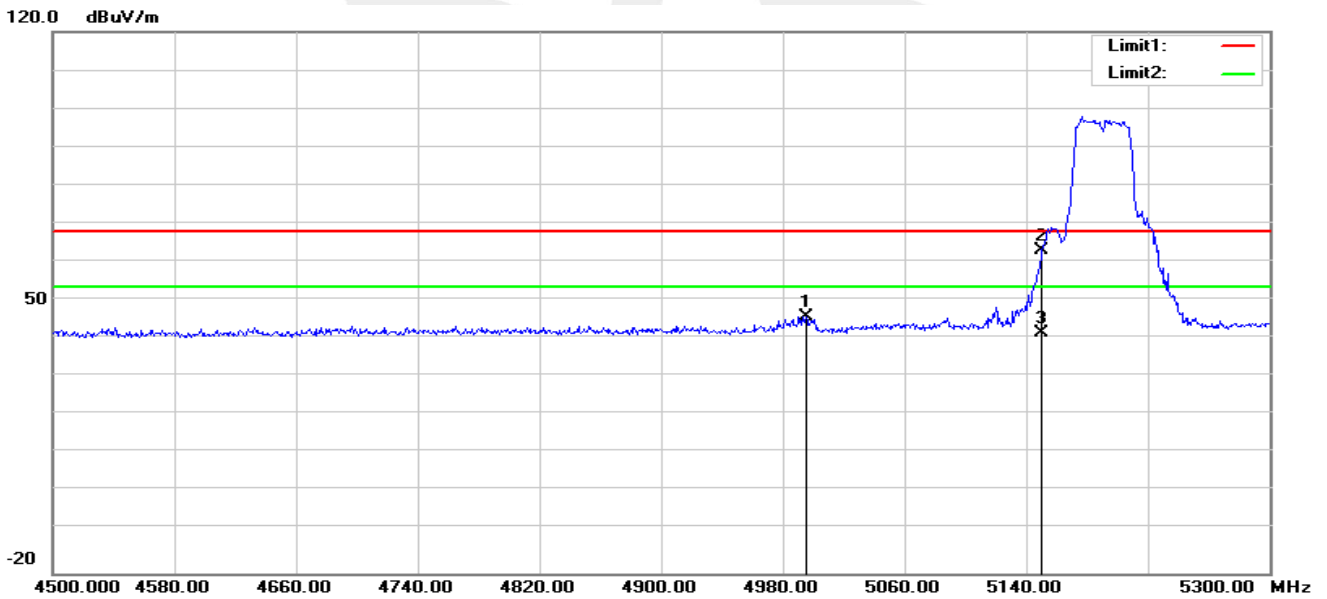

No.	Frequency (MHz)	Reading (dBuV)	Correct Factor(dB/m)	Result (dBuV/m)	Limit (dBuV/m)	Margin (dB)	Remark
1	4995.200	52.68	-6.22	46.46	68.20	-21.74	peak
2	5150.000	69.11	-5.73	63.38	68.20	-4.82	peak
3	5150.000	47.84	-5.73	42.11	54.00	-11.89	AVG



802.11n40-H-H

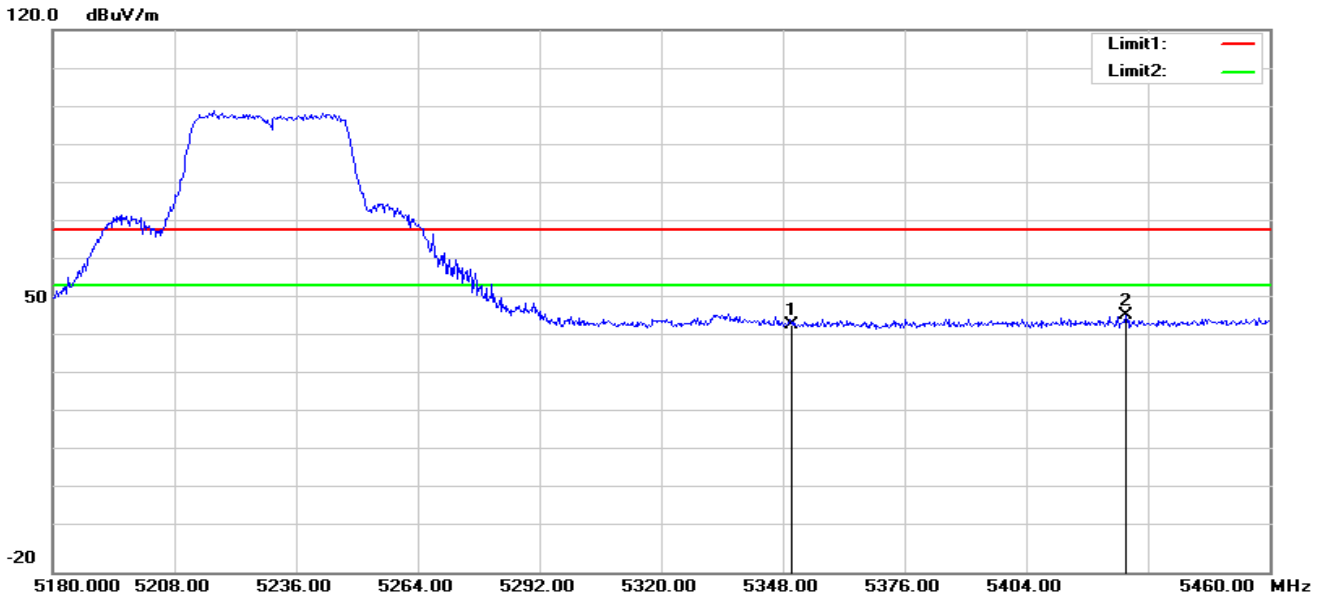

No.	Frequency (MHz)	Reading (dBuV)	Correct Factor(dB/m)	Result (dBuV/m)	Limit (dBuV/m)	Margin (dB)	Remark
1	5350.000	49.14	-5.23	43.91	68.20	-24.29	peak
2	5426.960	51.39	-5.19	46.20	68.20	-22.00	peak

802.11n40-H-V

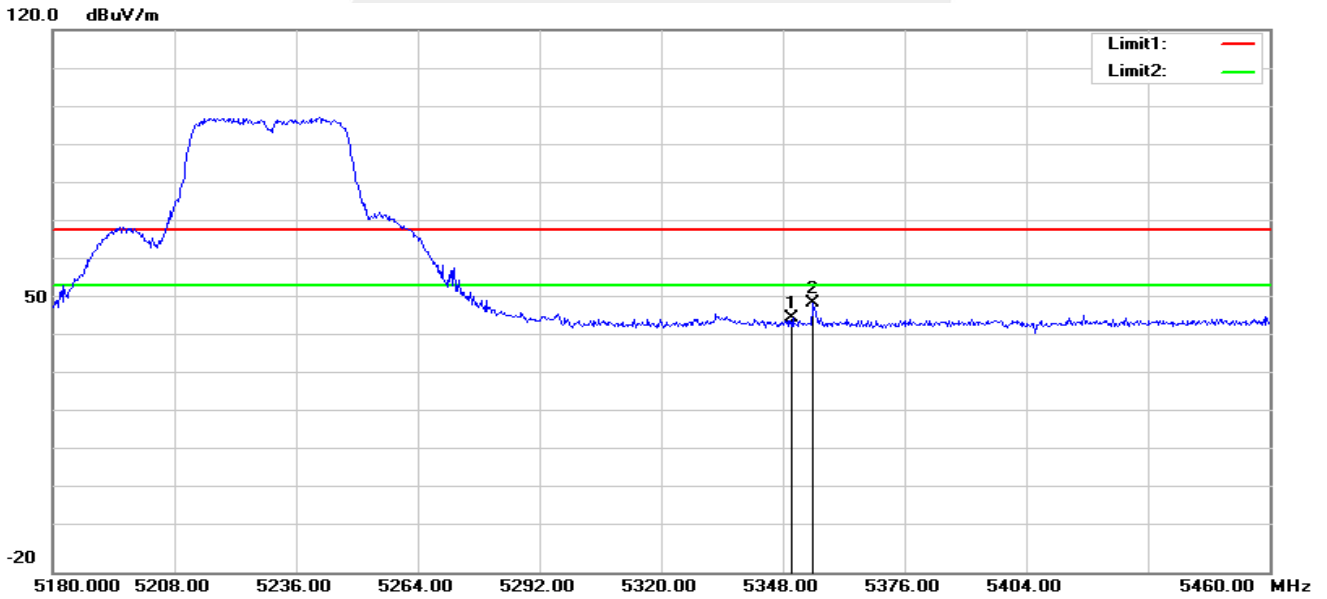

No.	Frequency (MHz)	Reading (dBuV)	Correct Factor(dB/m)	Result (dBuV/m)	Limit (dBuV/m)	Margin (dB)	Remark
1	5350.000	50.72	-5.23	45.49	68.20	-22.71	peak
2	5355.000	54.85	-5.24	49.61	68.20	-18.59	peak



802.11ac80-L-H

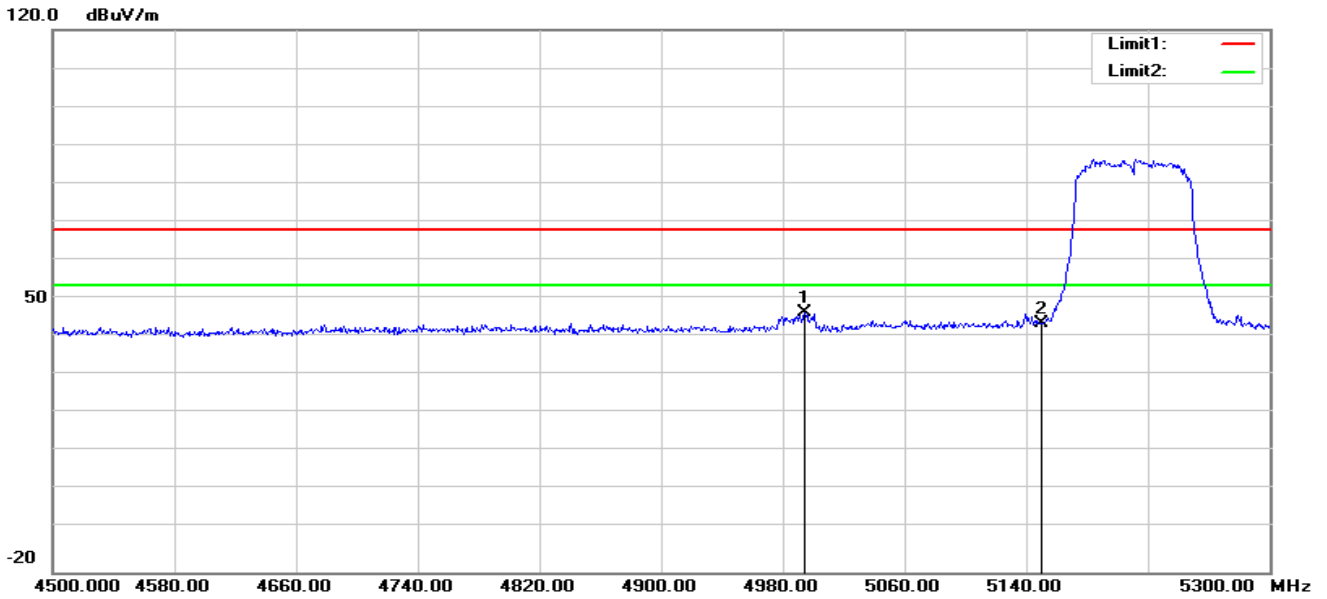

No.	Frequency (MHz)	Reading (dBuV)	Correct Factor(dB/m)	Result (dBuV/m)	Limit (dBuV/m)	Margin (dB)	Remark
1	4994.400	53.28	-6.23	47.05	68.20	-21.15	peak
2	5150.000	49.81	-5.73	44.08	68.20	-24.12	peak

802.11ac80-L-V

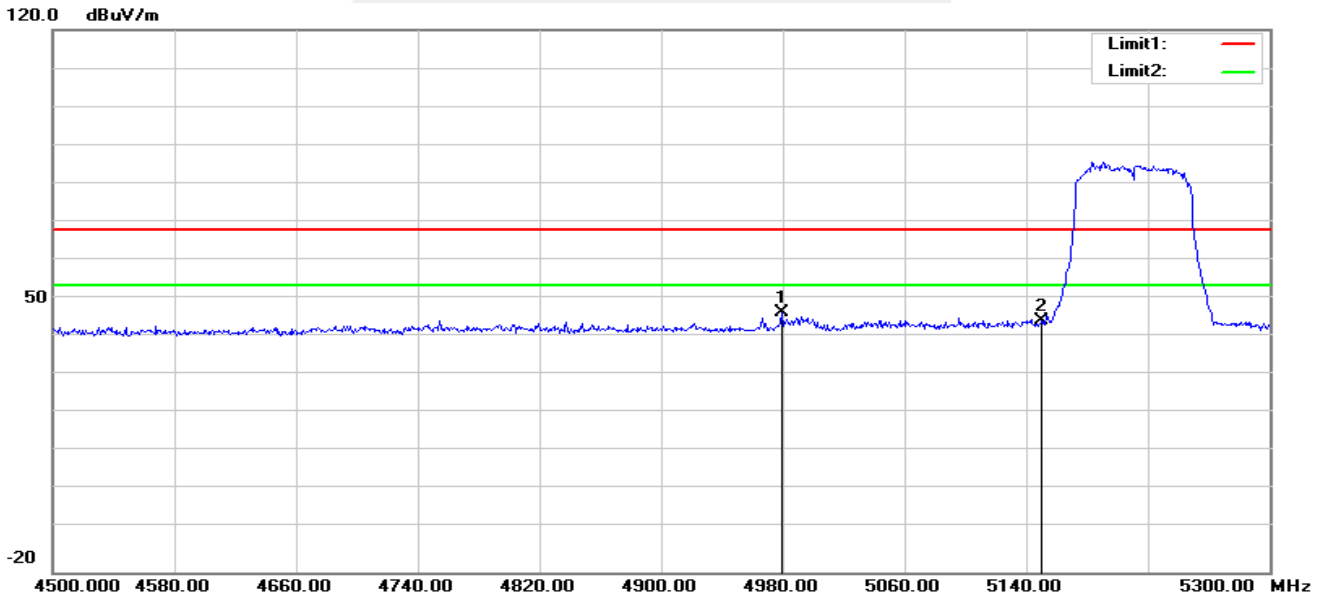

No.	Frequency (MHz)	Reading (dBuV)	Correct Factor(dB/m)	Result (dBuV/m)	Limit (dBuV/m)	Margin (dB)	Remark
1	4979.200	53.22	-6.32	46.90	68.20	-21.30	peak
2	5150.000	50.70	-5.73	44.97	68.20	-23.23	peak



802.11ac80-H-H

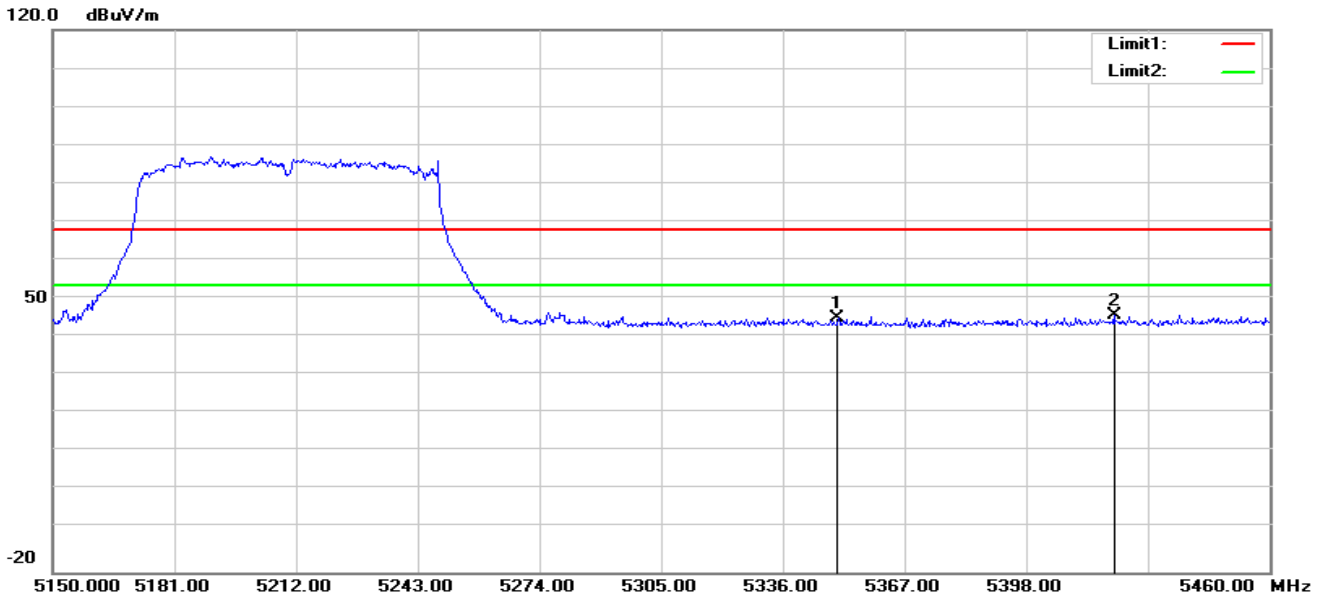

No.	Frequency (MHz)	Reading (dBuV)	Correct Factor(dB/m)	Result (dBuV/m)	Limit (dBuV/m)	Margin (dB)	Remark
1	5350.000	50.75	-5.23	45.52	68.20	-22.68	peak
2	5420.320	51.38	-5.20	46.18	68.20	-22.02	peak

802.11ac80-H-V

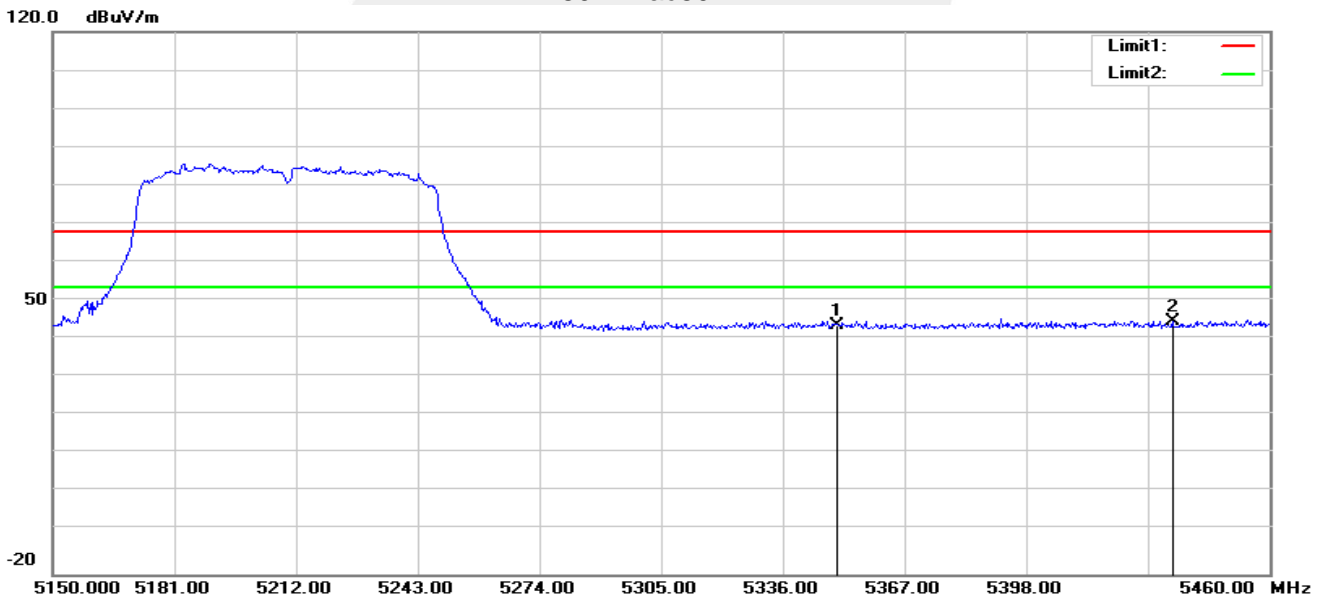

No.	Frequency (MHz)	Reading (dBuV)	Correct Factor(dB/m)	Result (dBuV/m)	Limit (dBuV/m)	Margin (dB)	Remark
1	5350.000	49.30	-5.23	44.07	68.20	-24.13	peak
2	5435.200	50.56	-5.17	45.39	68.20	-22.81	peak

Note: All modes have been tested. Only the worst mode shown in the report.



Band IV(5.725-5.85 GHz)

802.11ac20-L-H

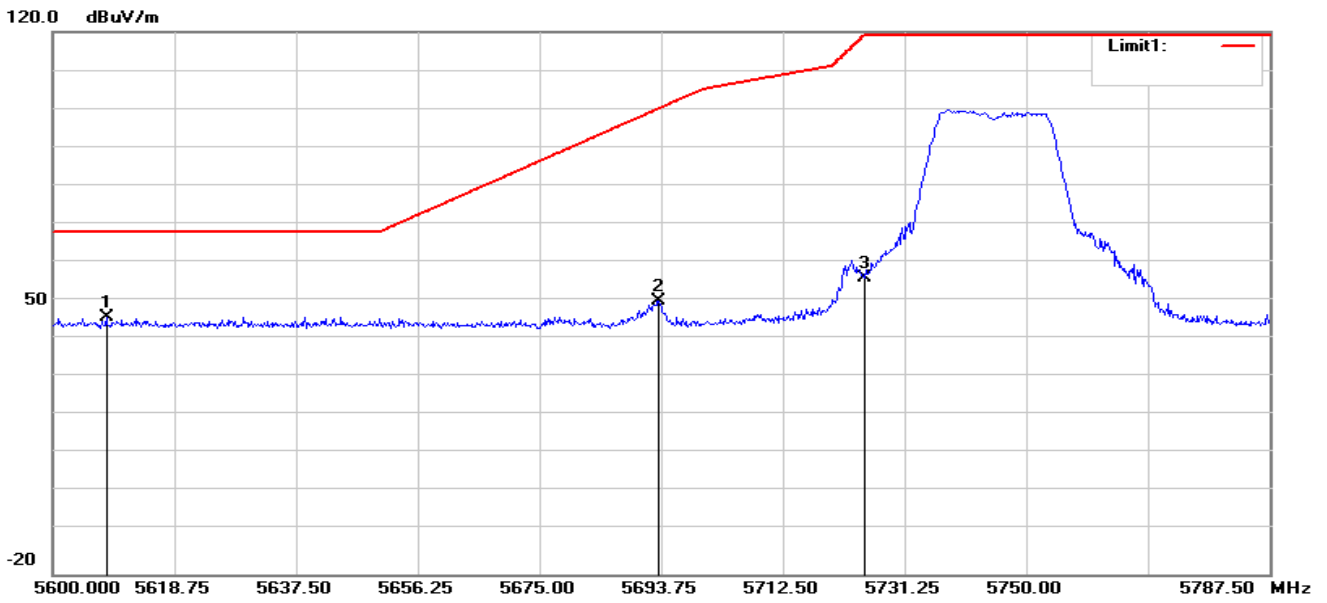

No.	Frequency (MHz)	Reading (dBuV)	Correct Factor(dB/m)	Result (dBuV/m)	Limit (dBuV/m)	Margin (dB)	Remark
1	5608.250	50.97	-4.70	46.27	68.20	-21.93	peak
2	5693.375	55.25	-4.66	50.59	100.30	-49.71	peak
3	5725.000	61.16	-4.57	56.59	119.20	-62.61	peak

802.11ac20-L-V

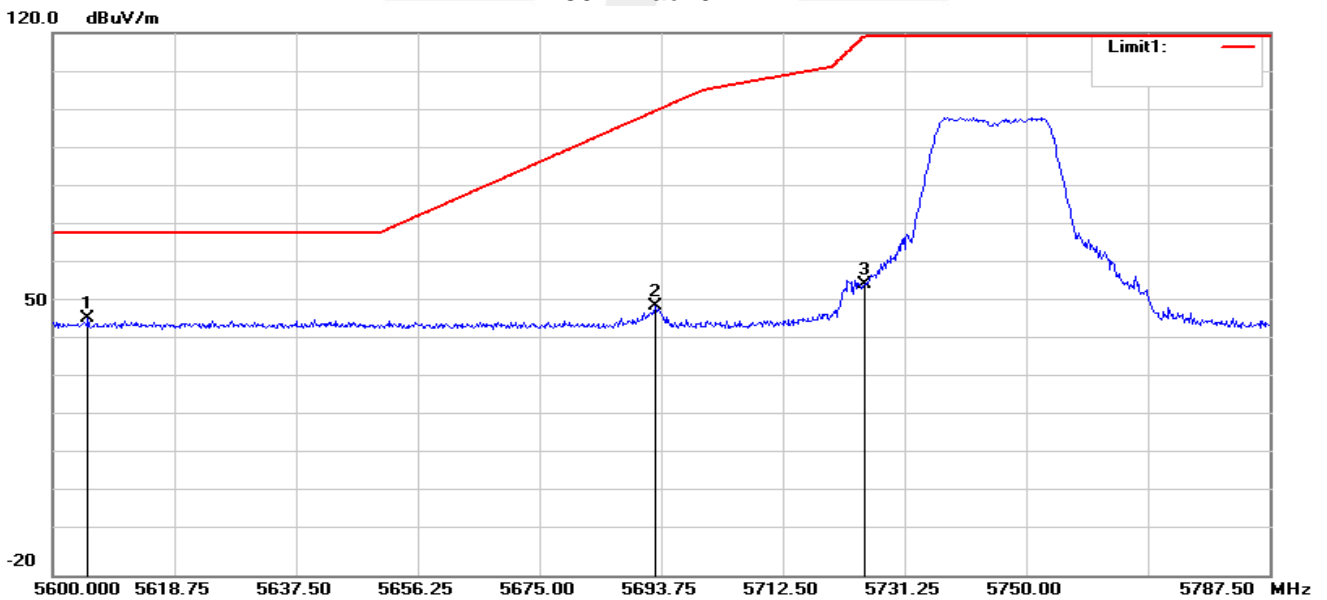

No.	Frequency (MHz)	Reading (dBuV)	Correct Factor(dB/m)	Result (dBuV/m)	Limit (dBuV/m)	Margin (dB)	Remark
1	5605.438	50.86	-4.70	46.16	68.20	-22.04	peak
2	5692.813	54.07	-4.66	49.41	99.88	-50.47	peak
3	5725.000	59.80	-4.57	55.23	119.20	-63.97	peak



802.11ac20-H-H

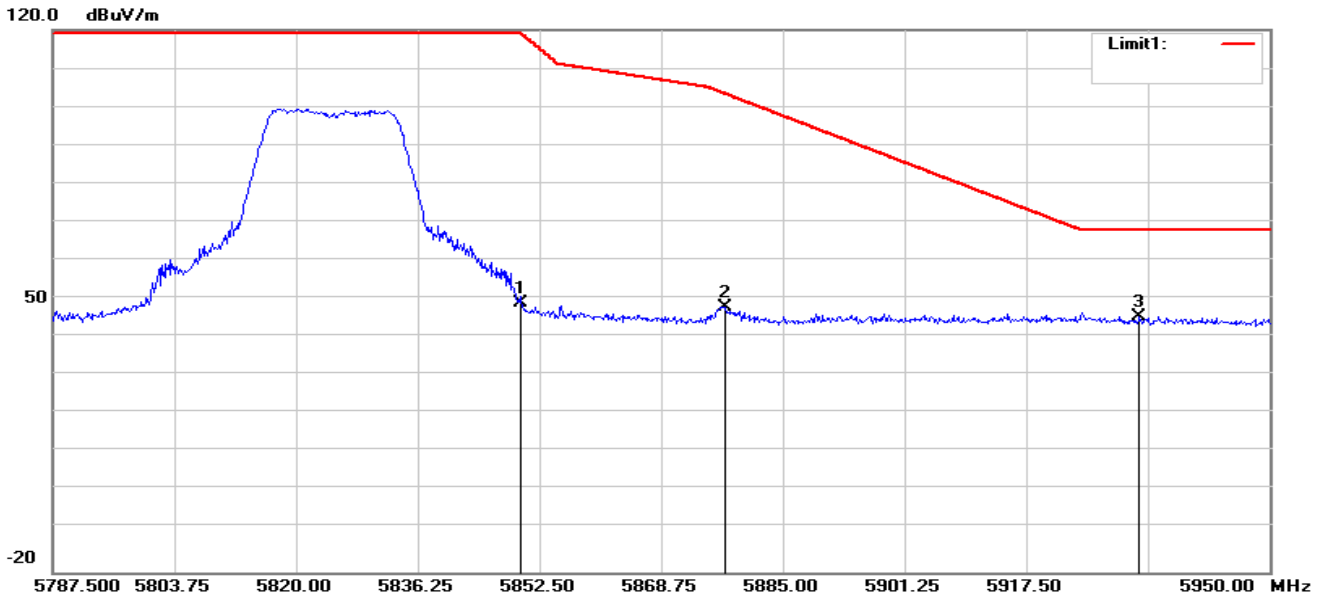

No.	Frequency (MHz)	Reading (dBuV)	Correct Factor(dB/m)	Result (dBuV/m)	Limit (dBuV/m)	Margin (dB)	Remark
1	5850.000	53.74	-4.10	49.64	119.20	-69.56	peak
2	5877.363	52.47	-3.98	48.49	103.45	-54.96	peak
3	5932.613	49.84	-3.94	45.90	68.20	-22.30	peak

802.11ac20-H-V

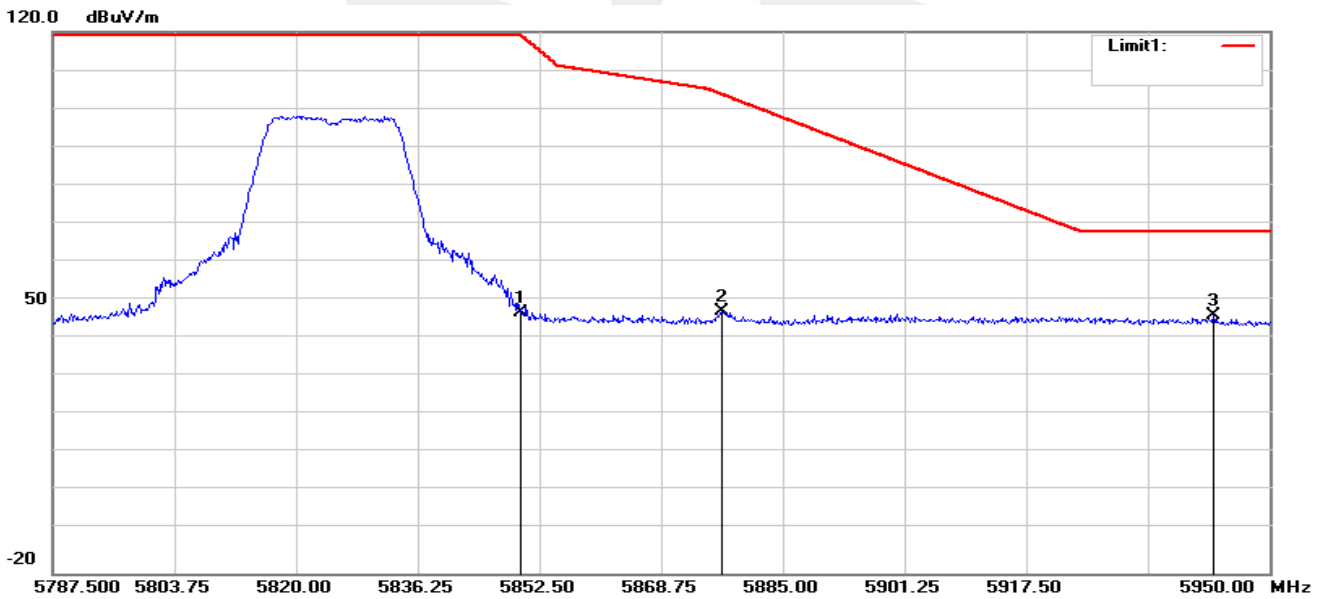

No.	Frequency (MHz)	Reading (dBuV)	Correct Factor(dB/m)	Result (dBuV/m)	Limit (dBuV/m)	Margin (dB)	Remark
1	5850.000	51.40	-4.10	47.30	119.20	-71.90	peak
2	5876.875	51.67	-3.98	47.69	103.81	-56.12	peak
3	5942.525	50.60	-3.95	46.65	68.20	-21.55	peak



802.11n40-L-H

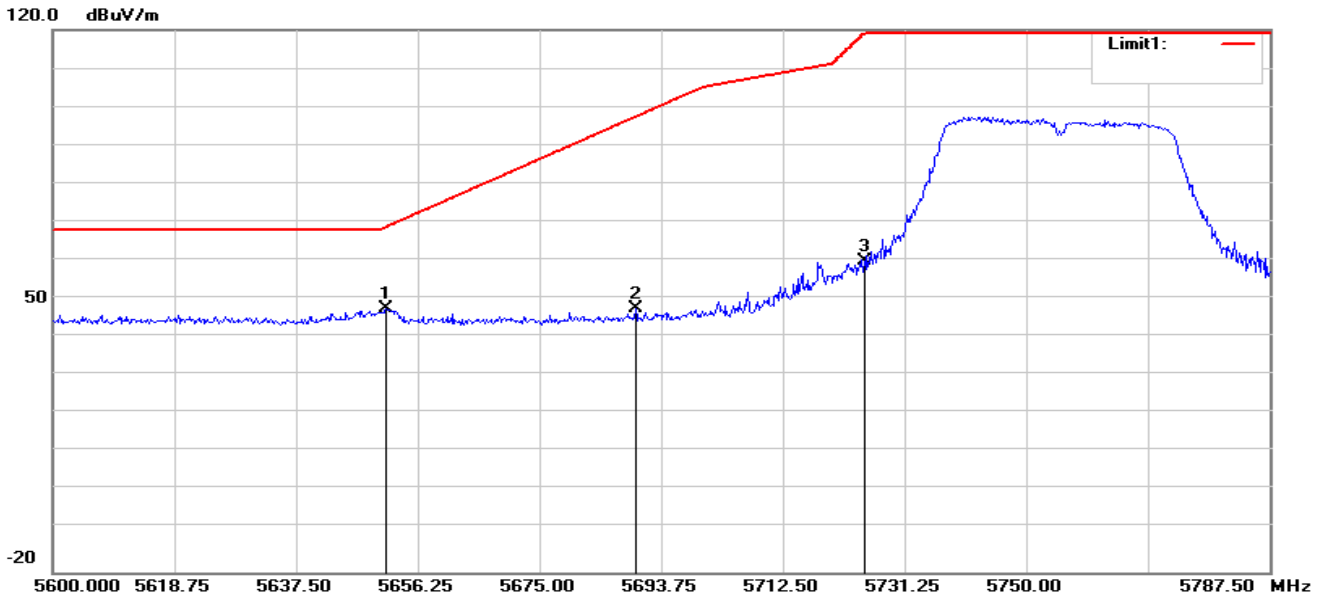

No.	Frequency (MHz)	Reading (dBuV)	Correct Factor(dB/m)	Result (dBuV/m)	Limit (dBuV/m)	Margin (dB)	Remark
1	5651.375	52.89	-4.68	48.21	69.22	-21.01	peak
2	5689.813	52.67	-4.67	48.00	97.66	-49.66	peak
3	5725.000	64.79	-4.57	60.22	119.20	-58.98	peak

802.11n40-L-V

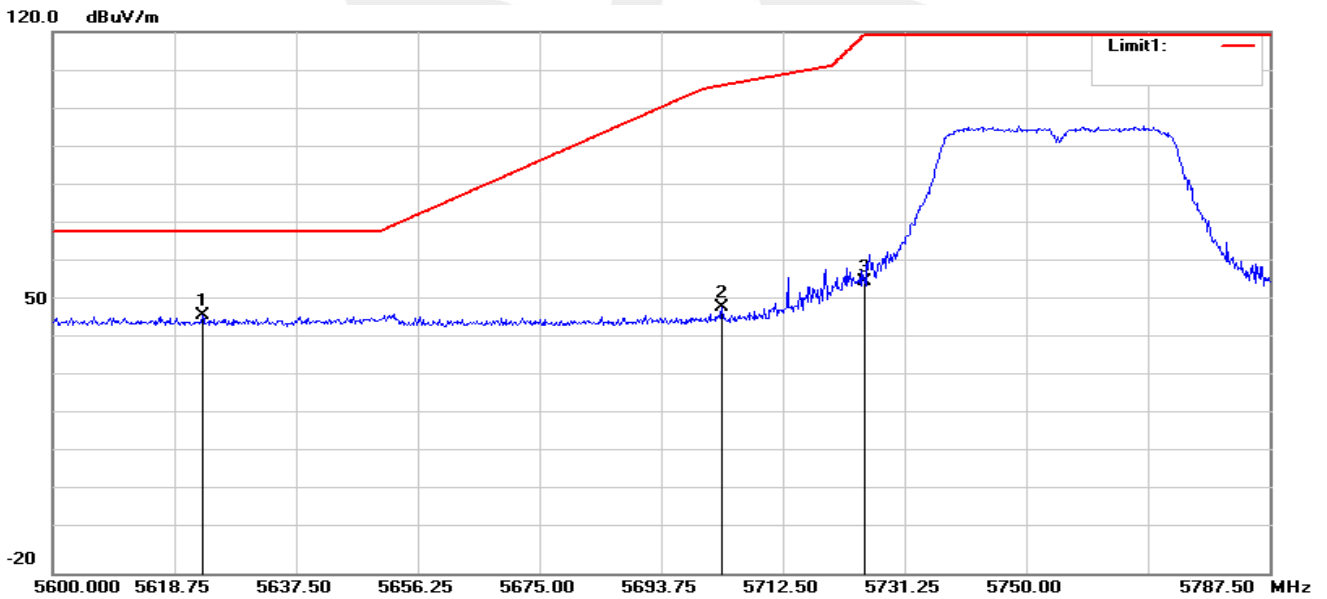

No.	Frequency (MHz)	Reading (dBuV)	Correct Factor(dB/m)	Result (dBuV/m)	Limit (dBuV/m)	Margin (dB)	Remark
1	5623.063	51.43	-4.69	46.74	68.20	-21.46	peak
2	5703.125	53.31	-4.65	48.66	106.14	-57.48	peak
3	5725.000	59.86	-4.57	55.29	119.20	-63.91	peak



802.11n40-H-H

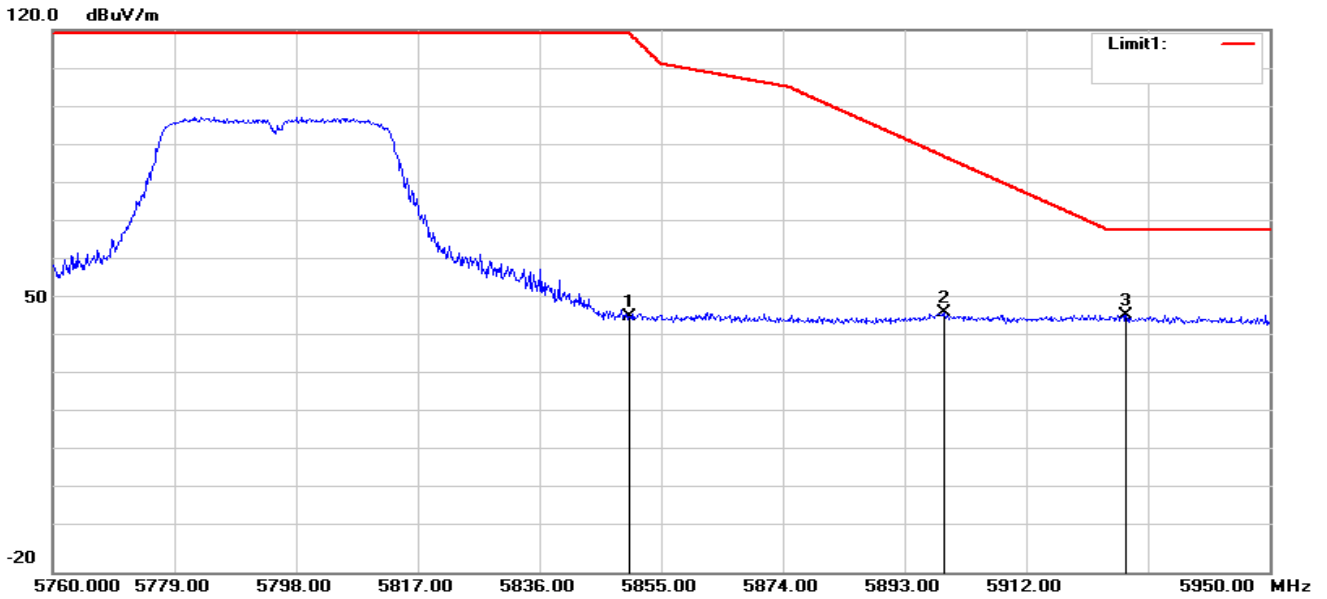

No.	Frequency (MHz)	Reading (dBuV)	Correct Factor(dB/m)	Result (dBuV/m)	Limit (dBuV/m)	Margin (dB)	Remark
1	5850.000	49.92	-4.10	45.82	119.20	-73.38	peak
2	5899.080	51.06	-3.88	47.18	87.38	-40.20	peak
3	5927.580	50.16	-3.93	46.23	68.20	-21.97	peak

802.11n40-H-V

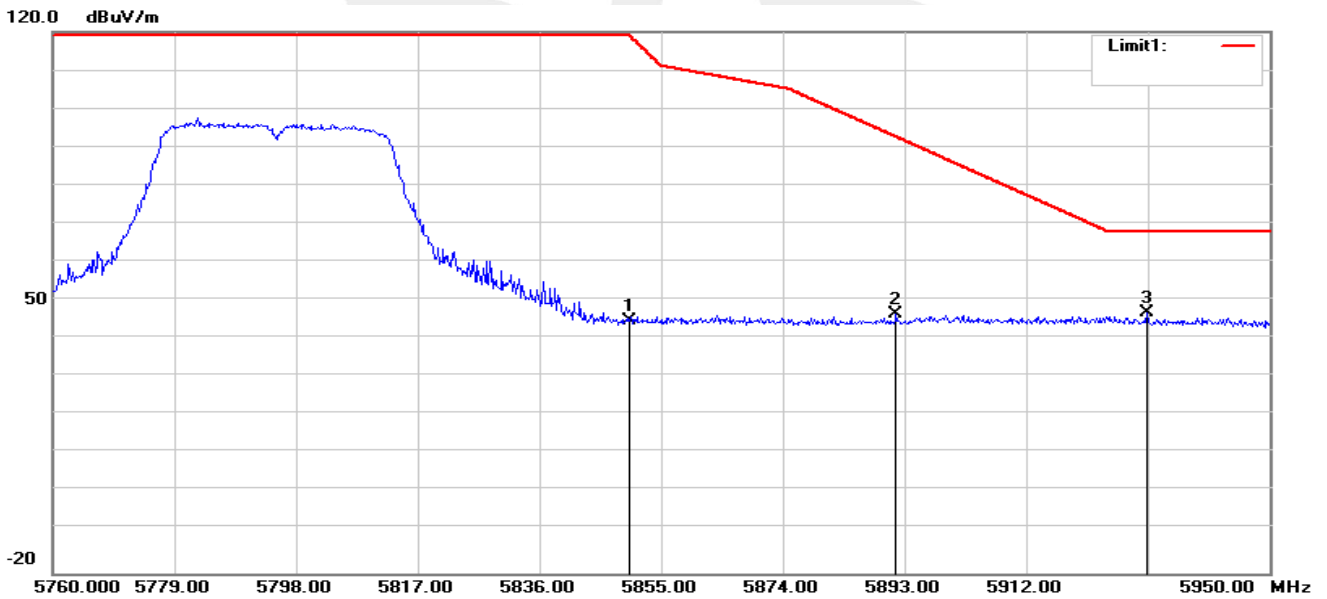

No.	Frequency (MHz)	Reading (dBuV)	Correct Factor(dB/m)	Result (dBuV/m)	Limit (dBuV/m)	Margin (dB)	Remark
1	5850.000	49.48	-4.10	45.38	119.20	-73.82	peak
2	5891.670	51.06	-3.91	47.15	92.86	-45.71	peak
3	5930.810	51.30	-3.93	47.37	68.20	-20.83	peak





802.11ac80-H

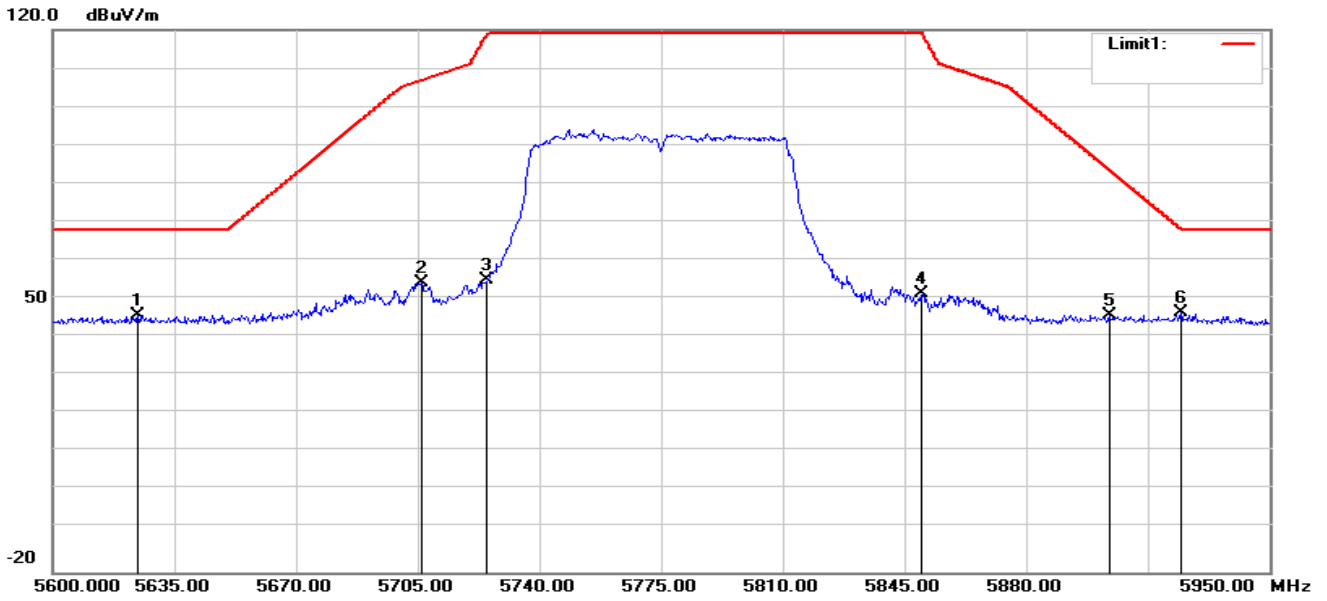

No.	Frequency (MHz)	Reading (dBuV)	Correct Factor(dB/m)	Result (dBuV/m)	Limit (dBuV/m)	Margin (dB)	Remark
1	5624.500	50.99	-4.69	46.30	68.20	-21.90	peak
2	5706.050	59.30	-4.64	54.66	107.02	-52.36	peak
3	5725.000	59.84	-4.57	55.27	119.20	-63.93	peak
4	5850.000	55.90	-4.10	51.80	119.20	-67.40	peak
5	5903.800	50.20	-3.88	46.32	83.89	-37.57	peak
6	5924.450	50.95	-3.92	47.03	68.61	-21.58	peak



802.11ac80-V

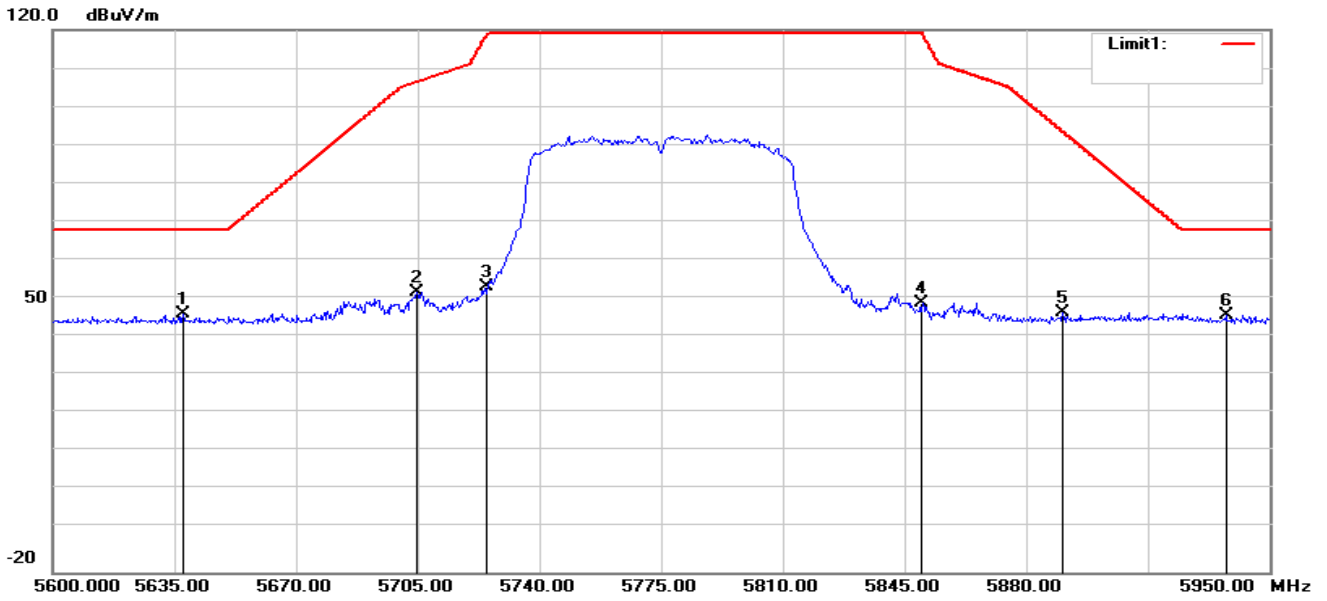

No.	Frequency (MHz)	Reading (dBuV)	Correct Factor(dB/m)	Result (dBuV/m)	Limit (dBuV/m)	Margin (dB)	Remark
1	5637.450	51.30	-4.68	46.62	68.20	-21.58	peak
2	5704.650	56.89	-4.64	52.25	106.59	-54.34	peak
3	5725.000	58.23	-4.57	53.66	119.20	-65.54	peak
4	5850.000	53.67	-4.10	49.57	119.20	-69.63	peak
5	5890.500	51.03	-3.93	47.10	93.73	-46.63	peak
6	5937.400	50.38	-3.94	46.44	68.20	-21.76	peak

Note: All modes have been tested. Only the worst mode shown in the report.



## 4. POWER SPECTRAL DENSITY TEST

### 4.1 LIMIT

1. For mobile and portable client devices in the 5.15-5.25 GHz band, , the maximum power spectral density shall not exceed 11 dBm in any 1 megahertz band. If transmitting antennas of directional gain greater than 6 dBi are used, both the maximum conducted output power and the maximum power spectral density shall be reduced by the amount in dB that the directional gain of the antenna exceeds 6 dBi.
2. For the 5.25-5.35 GHz and 5.47-5.725 GHz bands, the maximum power spectral density shall not exceed 11 dBm in any 1 megahertz band. If transmitting antennas of directional gain greater than 6 dBi are used, both the maximum conducted output power and the maximum power spectral density shall be reduced by the amount in dB that the directional gain of the antenna exceeds 6 dBi.
3. For the band 5.725-5.850 GHz, the peak power spectral density shall not exceed 30 dBm in any 500KHz band. If transmitting antenna directional gain is greater than 6 dBi, both the maximum conducted output power and the peak power spectral density shall be reduced by the amount in dB that the directional gain of the antenna exceeds 6 dBi.

### 4.2 TEST PROCEDURE

1. The setting follows Method SA-2 of FCC KDB 789033 D02 General UNII Test Procedures New Rules v02r01.
2. Set span to encompass the EBW
3. Set RBW = 1MHz.
4. Set the VBW  $\geq$  3MHz.
5. Number of points in sweep  $\geq 2 \times \text{span} / \text{RBW}$ . (This ensures that bin-to-bin spacing is  $\leq \text{RBW}/2$ , so that narrowband signals are not lost between frequency bins.)
6. Sweep time = auto.
7. Detector = power averaging (rms), if available. Otherwise, use sample detector mode
8. Trace average at least 100 traces in power averaging (rms) mode; however, the number of traces to be averaged shall be increased above 100 as needed to ensure that the average accurately represents the true average over the on and off periods of the transmitter.

### 4.3 DEVIATION FROM STANDARD

No deviation.

#### 4.4 TEST SETUP



#### 4.5 EUT OPERATION CONDITIONS

The EUT tested system was configured as the statements of 2.1 Unless otherwise a special operating condition is specified in the follows during the testing.

#### 4.6 TEST RESULTS

5150-5250MHz					
Frequency	Direct measurement Power Density (dBm)	Duty cycle factor (dB)	Final Power Density (dBm)	Limit (dBm)	Result
802.11a					
5180	-1.981	0.818	-1.163	11	PASS
5200	-1.948	0.818	-1.130	11	PASS
5240	-2.964	0.818	-2.146	11	PASS
802.11n20					
5180	-2.880	0.532	-2.348	11	PASS
5200	-2.340	0.532	-1.808	11	PASS
5240	-2.347	0.532	-1.815	11	PASS
802.11n40					
5190	-7.219	2.944	-4.275	11	PASS
5230	-7.104	2.944	-4.160	11	PASS
802.11ac20					
5180	-2.390	0.323	-2.067	11	PASS
5200	-2.405	0.323	-2.082	11	PASS
5240	-2.673	0.323	-2.350	11	PASS
802.11ac40					
5190	-7.342	3.301	-4.041	11	PASS
5230	-7.949	3.301	-4.648	11	PASS
802.11ac80					
5210	-18.672	2.457	-16.215	11	PASS



5725-5850MHz						
Frequency	Use RBW 510KHz direct measurement Direct measurement Power Density (dBm)	Convert to RBW 500KHz direct measurement Power Density (dBm)	Duty cycle factor (dB)	Final Power Density (dBm)	Limit (dBm)	Result
802.11a						
5745	-4.082	-4.168	0.527	-3.641	30	PASS
5785	-3.964	-4.050	0.527	-3.523	30	PASS
5825	-4.630	-4.716	0.527	-4.189	30	PASS
802.11n20						
5745	-6.124	-6.210	0.519	-5.691	30	PASS
5785	-6.587	-6.673	0.519	-6.154	30	PASS
5825	-4.405	-4.491	0.519	-3.972	30	PASS
802.11n40						
5755	-9.430	-9.516	3.010	-6.506	30	PASS
5795	-9.842	-9.928	3.010	-6.918	30	PASS
802.11ac20						
5745	-4.485	-4.571	0.741	-3.830	30	PASS
5785	-4.683	-4.769	0.741	-4.028	30	PASS
5825	-4.996	-5.082	0.741	-4.341	30	PASS
802.11ac40						
5755	-9.202	-9.288	1.416	-7.872	30	PASS
5795	-8.832	-8.918	1.416	-7.502	30	PASS
802.11ac80						
5775	-21.179	-21.265	2.457	-18.808	30	PASS

Note: 1. RB conversion formula:  $10 \cdot \text{LOG}(500\text{KHz}/\text{RBW})$   
 2. Test plots see Attachment A

## 5. BANDWIDTH MEASUREMENT

### 5.1 EMISSION BANDWIDTH (EBW) 26 BANDWID PROCEDURES / LIMIT

The following procedure shall be used for measuring 26 bandwidth.

#### 5.1.1 TEST PROCEDURE

1. The testing follows FCC KDB 789033 D02 General UNII Test Procedures New Rules v02r01
2. Set RBW = approximately 1% of the emission bandwidth.
3. Set the VBW  $\geq$  RBW.
4. Detector = Peak.
5. Trace mode = max hold.
6. Measure the maximum width of the emission that is 26 dB down from the peak of the emission. Compare this with the RBW setting of the analyzer. Readjust RBW and repeat measurement as needed until the RBW/EBW ratio is approximately 1%.

#### 5.1.2 DEVIATION FROM STANDARD

No deviation.

#### 6.1.3 TEST SETUP



#### 5.1.4 EUT OPERATION CONDITIONS

The EUT tested system was configured as the statements of 2.4 Unless otherwise a special operating condition is specified in the follows during the testing.

**5.1.5 TEST RESULTS**

Frequency (MHz)	26dB Bandwidth (MHz)	Pass/Fail
802.11a		
5180	21.58	Pass
5200	21.80	Pass
5240	21.90	Pass
802.11n(HT20)		
5180	22.17	Pass
5200	21.90	Pass
5240	21.86	Pass
802.11n(HT40)		
5190	41.84	Pass
5230	41.33	Pass
802.11ac(VHT20)		
5180	21.67	Pass
5200	21.58	Pass
5240	21.75	Pass
802.11ac(VHT40)		
5190	41.68	Pass
5230	41.27	Pass
802.11ac(VHT80)		
5210	82.97	Pass

Frequency (MHz)	26dB Bandwidth (MHz)	Pass/Fail
802.11a		
5745	21.98	Pass
5785	21.67	Pass
5825	21.85	Pass
802.11n(HT20)		
5745	21.71	Pass
5785	21.94	Pass
5825	22.03	Pass
802.11n(HT40)		
5755	40.99	Pass
5795	41.78	Pass
802.11ac(VHT20)		
5745	21.64	Pass
5785	21.67	Pass
5825	21.55	Pass
802.11ac(VHT40)		
5755	41.76	Pass
5795	42.34	Pass
802.11ac(VHT80)		
5775	82.07	Pass

Test plot see Attachment B

## 5.2 OCCUPIED BANDWIDTH ( 99%) TEST APPLIED PROCEDURES / LIMIT

The following procedure shall be used for measuring (99 %) power bandwidth.

### 5.2.1 TEST PROCEDURE

1. The testing follows FCC KDB 789033 D02 General UNII Test Procedures v02r01.  
The following procedure shall be used for measuring (99 %) power bandwidth:
  1. Set center frequency to the nominal EUT channel center frequency.
  2. Set span = 1.5 times to 5.0 times the OBW.
  3. Set RBW = 1 % to 5 % of the OBW
  4. Set VBW  $\geq 3 \cdot$  RBW
  5. Video averaging is not permitted. Where practical, a sample detection and single sweep mode shall be used. Otherwise, peak detection and max hold mode (until the trace stabilizes) shall be used.
  6. Use the 99 % power bandwidth function of the instrument (if available).
  7. If the instrument does not have a 99 % power bandwidth function, the trace data points are recovered and directly summed in power units. The recovered amplitude data points, beginning at the lowest frequency, are placed in a running sum until 0.5 % of the total is reached; that frequency is recorded as the lower frequency. The process is repeated until 99.5 % of the total is reached; that frequency is recorded as the upper frequency. The 99% occupied bandwidth is the difference between these two frequencies.

### 5.2.2 DEVIATION FROM STANDARD

No deviation.

### 5.2.3 TEST SETUP



### 5.2.4 EUT OPERATION CONDITIONS

The EUT tested system was configured as the statements of 2.4 Unless otherwise a special operating condition is specified in the follows during the testing.



**5.2.5 TEST RESULTS**

Frequency (MHz)	99% Bandwidth (MHz)	Pass/Fail
802.11a		
5180	16.71	Pass
5200	16.72	Pass
5240	16.73	Pass
802.11n(HT20)		
5180	17.82	Pass
5200	17.83	Pass
5240	17.81	Pass
802.11n(HT40)		
5190	36.13	Pass
5230	36.11	Pass
802.11ac(VHT20)		
5180	17.81	Pass
5200	17.80	Pass
5240	17.80	Pass
802.11ac(VHT40)		
5190	36.18	Pass
5230	36.18	Pass
802.11ac(VHT80)		
5210	74.66	Pass

Frequency (MHz)	99% Bandwidth (MHz)	Pass/Fail
802.11a		
5745	16.69	Pass
5785	16.70	Pass
5825	16.72	Pass
802.11n(HT20)		
5745	17.81	Pass
5785	17.80	Pass
5825	17.78	Pass
802.11n(HT40)		
5755	36.11	Pass
5795	36.15	Pass
802.11ac(VHT20)		
5745	17.79	Pass
5785	17.80	Pass
5825	17.80	Pass
802.11ac(VHT40)		
5755	36.27	Pass
5795	36.28	Pass
802.11ac(VHT80)		
5775	74.75	Pass

Test plot See Attachment B

### 5.3 MINIMUM EMISSION BANDWIDTH(6 DB) PROCEDURES / LIMIT

Section 15.407(e) specifies the minimum 6 dB emission bandwidth of at least 500 KHz for the band 5.725-5.85 GHz. The following procedure shall be used for measuring this bandwidth.

#### 5.3.1 TEST PROCEDURE

1. The testing follows FCC KDB 789033 D02 General UNII Test Procedures v02r01.
  - a) Set RBW = 100 kHz.
  - b) Set the video bandwidth (VBW)  $\geq 3 \times$  RBW.
  - c) Detector = Peak.
  - d) Trace mode = max hold.
  - e) Sweep = auto couple.
  - f) Allow the trace to stabilize.
  - g) Measure the maximum width of the emission that is constrained by the frequencies associated with the two outermost amplitude points (upper and lower frequencies) that are attenuated by 6 dB relative to the maximum level measured in the fundamental emission.

#### 5.3.2 DEVIATION FROM STANDARD

No deviation.

#### 5.3.3 TEST SETUP



#### 5.3.4 EUT OPERATION CONDITIONS

The EUT tested system was configured as the statements of 2.4 Unless otherwise a special operating condition is specified in the follows during the testing.

**6.3.5 TEST RESULTS**

Frequency (MHz)	6dB Bandwidth (MHz)	Pass/Fail
802.11a		
5745	16.46	Pass
5785	16.42	Pass
5825	16.40	Pass
802.11n(HT20)		
5745	17.63	Pass
5785	17.60	Pass
5825	17.60	Pass
802.11n(HT40)		
5755	36.02	Pass
5795	35.53	Pass
802.11ac(VHT20)		
5745	17.62	Pass
5785	17.60	Pass
5825	17.60	Pass
802.11ac(VHT40)		
5755	35.15	Pass
5795	35.44	Pass
802.11ac(VHT80)		
5775	73.86	Pass

Test plot see Attachment C

## 6. MAXIMUM CONDUCTED OUTPUT POWER

### 6.1 LIMIT

For mobile and portable client devices in the 5.15-5.25 GHz band, the maximum conducted output power over the frequency band of operation shall not exceed 250 mW provided the maximum antenna gain does not exceed 6 dBi. If transmitting antennas of directional gain greater than 6 dBi are used, both the maximum conducted output power and the maximum power spectral density shall be reduced by the amount in dB that the directional gain of the antenna exceeds 6 dBi.

For the 5.25-5.35 GHz and 5.47-5.725 GHz bands, the maximum conducted output power over the frequency bands of operation shall not exceed the lesser of 250 mW or 11 dBm + 10 log B, where B is the 26 dB emission bandwidth in megahertz, If transmitting antennas of directional gain greater than 6 dBi are used.

For the band 5.725-5.85 GHz, the maximum conducted output power over the frequency band of operation shall not exceed 1 W. If transmitting antennas of directional gain greater than 6 dBi are used.

FCC Part15 (15.407) , Subpart E				
Section	Test Item	Limit	Frequency Range (MHz)	Result
15.407(a) (1) (iv)	Peak Output Power	0.25 watt	5150-5250	PASS
		The lesser of 250 mW or 11 dBm + 10 log (26 dB emission bandwidth)	5250-5350 5470-5725	
15.407(a) (3)		1 watt	5725-5825	

### 6.2 TEST PROCEDURE

The EUT was directly connected to the Power Sensor&PC

### 6.3 DEVIATION FROM STANDARD

No deviation.

### 6.4 TEST SETUP

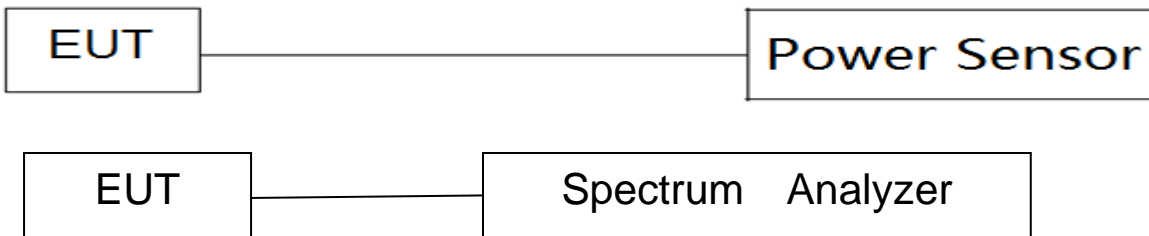

### 6.5 EUT OPERATION CONDITIONS

The EUT tested system was configured as the statements of 5 Unless otherwise a special operating condition is specified in the follows during the testing.

**6.6 TEST RESULTS**

Band I (5.15-5.25GHz)					
Test Channel	Frequency (MHz)	Direct measurement AV Power (dBm)	Duty cycle factor (dB)	Final AV Power (dBm)	LIMIT (dBm)
802.11a					
36	5180	8.47	0.818	9.29	23.98
40	5200	8.19	0.818	9.01	23.98
48	5240	7.98	0.818	8.80	23.98
802.11n(HT20)					
36	5180	8.43	0.532	8.96	23.98
40	5200	8.17	0.532	8.70	23.98
48	5240	7.93	0.532	8.46	23.98
802.11n(HT40)					
38	5190	6.30	2.944	9.24	23.98
46	5230	4.99	2.944	7.93	23.98
802.11ac(VHT20)					
36	5180	8.23	0.323	8.55	23.98
40	5200	7.97	0.323	8.29	23.98
48	5240	7.74	0.323	8.06	23.98
802.11ac(VHT40)					
38	5190	4.72	3.301	8.02	23.98
46	5230	4.06	3.301	7.36	23.98
802.11ac(VHT80)					
42	5210	6.01	2.457	8.47	23.98



Band IV (5.725-5.85GHz)					
Test Channel	Frequency (MHz)	Direct measurement AV Power (dBm)	Duty cycle factor (dB)	Final AV Power (dBm)	LIMIT (dBm)
802.11a					
149	5745	9.14	0.527	9.67	30.00
157	5785	9.22	0.527	9.75	30.00
165	5825	9.15	0.527	9.68	30.00
802.11n(HT20)					
149	5745	9.12	0.519	9.64	30.00
157	5785	9.20	0.519	9.72	30.00
165	5825	9.15	0.519	9.67	30.00
802.11n(HT40)					
151	5755	6.16	3.010	9.17	30.00
159	5795	5.39	3.010	8.40	30.00
802.11ac(VHT20)					
149	5745	8.95	0.741	9.69	30.00
157	5785	8.99	0.741	9.73	30.00
165	5825	9.00	0.741	9.74	30.00
802.11ac(VHT40)					
151	5755	5.56	1.416	6.98	30.00
159	5795	6.16	1.416	7.58	30.00
802.11ac(VHT80)					
155	5775	7.04	2.457	9.50	30.00

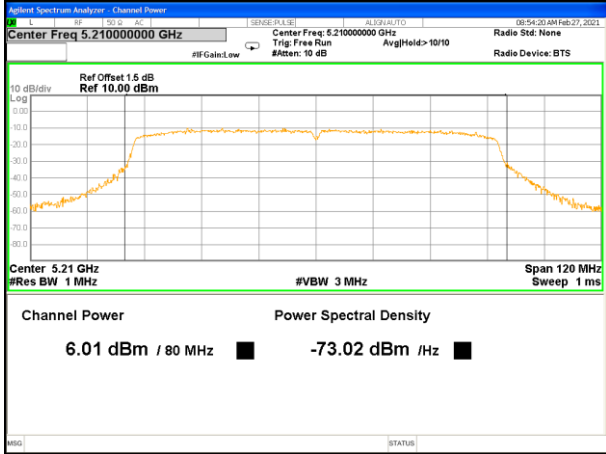

5210MHz

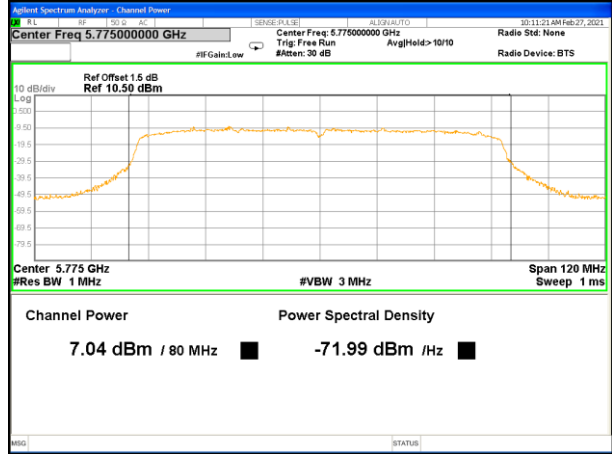

5775MHz





## Duty cycle

Band1				
Mode	Ton(ms)	Tp(ms)	Duty cycle(%)	Duty factor(dB)
a	1.380	1.666	82.83%	0.818
n20	1.305	1.475	88.47%	0.532
n40	0.197	0.388	50.77%	2.944
ac20	1.100	1.185	92.83%	0.323
ac40	0.166	0.355	46.76%	3.301
ac80	0.255	0.449	56.79%	2.457
Band4				
Mode	Ton(ms)	Tp(ms)	Duty cycle(%)	Duty factor(dB)
a	1.395	1.575	88.57%	0.527
n20	1.300	1.465	88.74%	0.519
n40	0.193	0.386	50.00%	3.010
ac20	0.995	1.180	84.32%	0.741
ac40	0.498	0.690	72.17%	1.416
ac80	0.255	0.449	56.79%	2.457





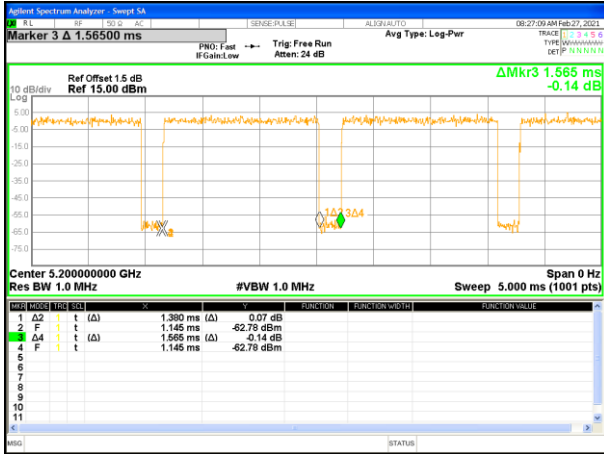

Band 1-a20



Band 1-n20

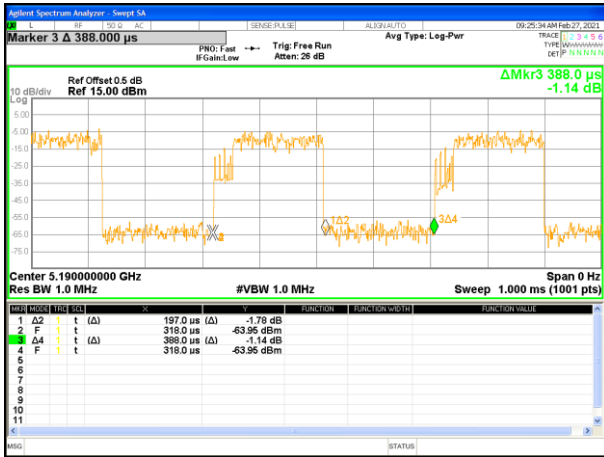

Band 1-n40



Band 1-ac20



Band 1-ac40

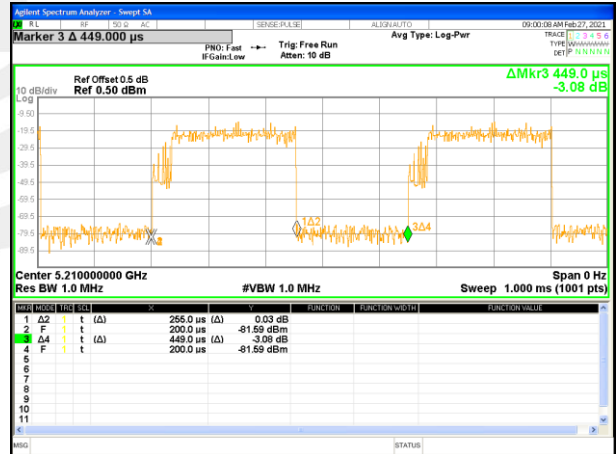

Band 1-ac80

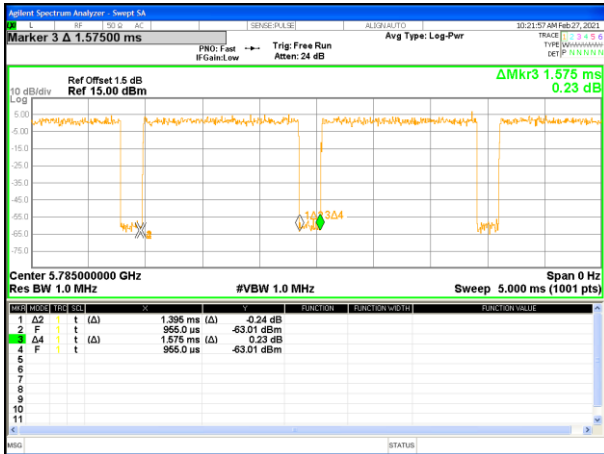

Band 4-a20

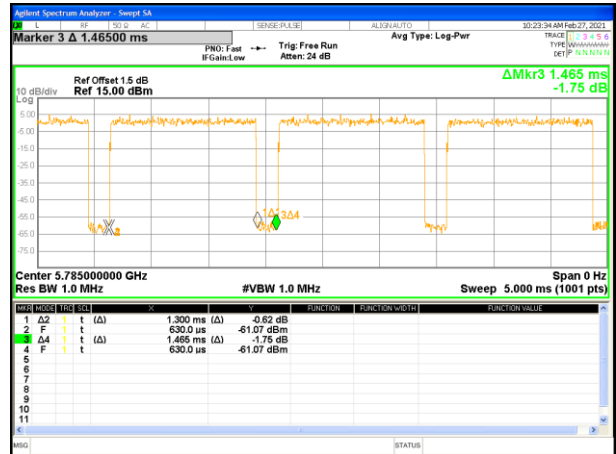

Band 4-n20



Band 4-n40

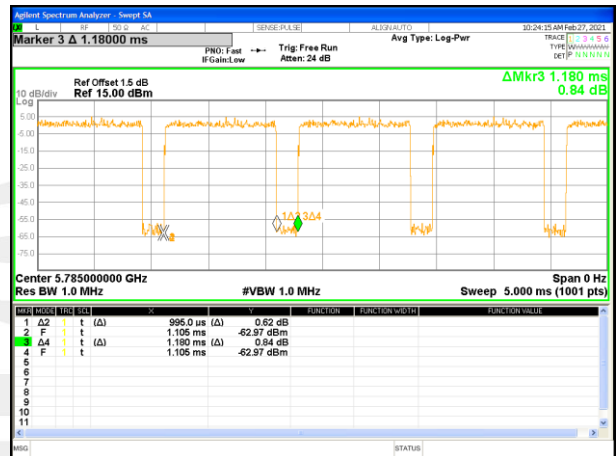

Band 4-ac20



Band 4-ac40



Band 4-ac80



## 7. AUTOMATICALLY DISCONTINUE TRANSMISSION

### 7.1 LIMIT OF AUTOMATICALLY DISCONTINUE TRANSMISSION

The device shall automatically discontinue transmission in case of either absence of information to transmit or operational failure. These provisions are not intended to preclude the transmission of control or signaling information or the use of repetitive codes used by certain digital technologies to complete frame or burst intervals. Applicants shall include in their application for equipment authorization to describe how this requirement is met.

### 7.2 TEST RESULT OF AUTOMATICALLY DISCONTINUE TRANSMISSION

During no any information transmission, the EUT can automatically discontinue transmission and become standby mode for power saving. The EUT can detect the controlling signal of ACK message transmitting from remote device and verify whether it shall resend or discontinue transmission.





## 8. ANTENNA REQUIREMENT

### 8.1 STANDARD REQUIREMENT

15.203 requirement: For intentional device, according to 15.203: an intentional radiator shall be designed to ensure that no antenna other than that furnished by the responsible party shall be used with the device.

### 8.2 EUT ANTENNA

The EUT antenna is PIFA Antenna. It comply with the standard requirement.





## APPENDIX - PHOTOS OF TEST SETUP

Note: See test photos in setup photo document for the actual connections between Product and support equipment.

※※※※※END OF THE REPORT※※※※※

