

FCC CERTIFICATION TEST REPORT

FOR

Applicant	:	SHENZHEN EPQI TECHNOLOGY CO., LTD
Address	:	Floor 6, Block 7, Zhongyuntai Industry Park, Songbai Road, Shiyan Town, Bao'an District, Shenzhen, China.
Equipment under Test	:	wireless charger
Model No.	:	ES300A, ES300B, ES300C, ES300D, ES300E, ES300F, ES400A, ES400B, ES400C, ES400D, ES400E, ES400F
Trade Mark	:	EPQI
FCC ID	:	2AOPC-ES300
Manufacturer	:	SHENZHEN EPQI TECHNOLOGY CO., LTD
Address	:	Floor 6, Block 7, Zhongyuntai Industry Park, Songbai Road, Shiyan Town, Bao'an District, Shenzhen, China.

Issued By: Dongguan Dongdian Testing Service Co., Ltd.

Add: No. 17, Zongbu Road 2, Songshan Lake Sci&Tech, Industry Park, Dongguan
City, Guangdong Province, China, 523808

Tel: +86-0769-89201699, **E-mail:** ddt@dgddt.com, <http://www.dgddt.com>

REPORT

TABLE OF CONTENTS

	Test report declares.....	3
1	Summary of test results	4
2	General test information	5
2.1.	Description of EUT	5
2.2.	Accessories of EUT.....	5
2.3.	Assistant equipment used for test.....	5
2.4.	Block diagram of EUT configuration for test.....	5
2.5.	Deviations of test standard.....	5
2.6.	Test environment conditions	6
2.7.	Test laboratory	6
2.8.	Measurement uncertainty	6
3	Equipment used during test	7
4	20dB Bandwidth.....	8
4.1.	Block diagram of test setup.....	8
4.2.	Limits	8
4.3.	Test Procedure.....	8
4.4.	Test Result.....	8
4.5.	Original test data.....	9
5	Radiated emission	10
5.1.	Block diagram of test setup.....	10
5.2.	Limit	11
5.3.	Test Procedure.....	11
5.4.	Test result	12
6	Power Line Conducted Emission	15
6.1.	Block diagram of test setup.....	15
6.2.	Power Line Conducted Emission Limits.....	15
6.3.	Test Procedure.....	15
6.4.	Test Result.....	16
7	Antenna Requirements	19

TEST REPORT DECLARE

Applicant	:	SHENZHEN EPQI TECHNOLOGY CO., LTD
Address	:	Floor 6, Block 7, Zhongyuntai Industry Park, Songbai Road, Shiyan Town, Bao'an District, Shenzhen, China.
Equipment under Test	:	wireless charger
Model No.	:	ES300A, ES300B, ES300C, ES300D, ES300E, ES300F, ES400A, ES400B, ES400C, ES400D, ES400E, ES400F
Trade Mark	:	EPQI
Manufacturer	:	SHENZHEN EPQI TECHNOLOGY CO., LTD
Address	:	Floor 6, Block 7, Zhongyuntai Industry Park, Songbai Road, Shiyan Town, Bao'an District, Shenzhen, China.

Test Standard Used:

FCC Rules and Regulations Part 15 Subpart C

Test procedure used:

ANSI C63.10:2013

We Declare:

The equipment described above is tested by Dongguan Dongdian Testing Service Co., Ltd and in the configuration tested the equipment complied with the standards specified above. The test results are contained in this test report and Dongguan Dongdian Testing Service Co., Ltd is assumed of full responsibility for the accuracy and completeness of these tests.

After test and evaluation, our opinion is that the equipment provided for test compliance with the requirement of the above FCC standards.

Report No:	DDT-R17122905-3E2		
Date of Test:	Jan. 05, 2018~Jan. 25, 2018	Date of Report:	Jan. 25, 2018

Prepared By:

Sam Li

Sam Li/Engineer

Approved By:



Kevin Feng/EMC Manager

Note: This report applies to above tested sample only. This report shall not be reproduced in parts without written approval of Dongguan Dongdian Testing Service Co., Ltd.

1 Summary of test results

Description of Test Item	Standard	Results
20dB Bandwidth	FCC Part 15: 15.215	PASS
Radiated Emission	FCC Part 15: 15.209	PASS
Power Line Conducted Emissions	FCC Part 15: 15.207	PASS
Antenna requirement	FCC Part 15: 15.203	PASS

2 General test information

2.1. Description of EUT

EUT* Name	: wireless charger
Model Number	: ES300A, ES300B, ES300C, ES300D, ES300E, ES300F, ES400A, ES400B, ES400C, ES400D, ES400E, ES400F
Difference of model number	: All models are identical, except the model number and colors, all tests are performed on model ES300A.
EUT function description	: Please reference user manual of this device
Power supply	: DC 5V or 9V from external AC Adapter
Wireless charging Operation frequency	: 120kHz-210kHz
Antenna Type	: Inductive loop coil antenna
Sample Type	: Series production

Note: EUT is the ab. of equipment under test.

2.2. Accessories of EUT

Description of Accessories	Manufacturer	Model number or Type	Serial No.	Other
/	/	/	/	/

2.3. Assistant equipment used for test

Assistant equipment	Manufacturer	Model number or Type	EMC Compliance	Other
Simulation load	/	/	/	/
USB cable	/	/	/	/
AC adapter	HUAWEI	HW-050200C3 W	/	Input: AC 100-240V 50/60Hz 0.5A MAX Output: DC 5.0V 2A

2.4. Block diagram of EUT configuration for test

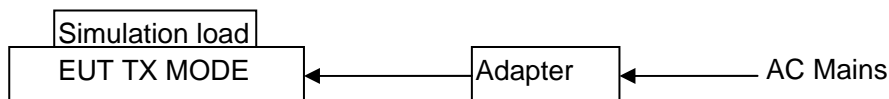

2.5. Deviations of test standard

No Deviation.

2.6. Test environment conditions

During the measurement the environmental conditions were within the listed ranges:

Temperature range:	21-25°C
Humidity range:	40-75%
Pressure range:	86-106kPa

2.7. Test laboratory

Dongguan Dongdian Testing Service Co., Ltd

Add: No. 17, Zongbu Road 2, Songshan Lake Sci&Tech, Industry Park, Dongguan City, Guangdong Province, China, 523808

Tel: +86-0769-89201699, E-mail: ddt@dgddt.com, <http://www.dgddt.com>

FCC Registration Number: 270092; Industry Canada site registration number: 10288A-1

2.8. Measurement uncertainty

Test Item	Uncertainty
Uncertainty for Conduction emission test	3.32dB (150kHz-30MHz)
	3.72dB (9kHz-150kHz)
Uncertainty for Radiation Emission test (30MHz-1GHz)	4.70 dB (Antenna Polarize: V)
	4.84 dB (Antenna Polarize: H)
Uncertainty for Radiation Emission test (1GHz to 18GHz)	4.10dB(1-6GHz)
	4.40dB (6GHz-18GHz)
Bandwidth	1.1%
Note: This uncertainty represents an expanded uncertainty expressed at approximately the 95% confidence level using a coverage factor of k=2.	

3 Equipment used during test

Equipment	Manufacturer	Model No.	Serial No.	Last Cal.	Cal. Interval
RF Connected Test					
Spectrum analyzer	R&S	FSU26	200071	Oct. 23, 2017	1Year
Wideband Radio Communication tester	R&S	CMW500	117491	Jun. 16, 2017	1Year
Vector Signal Generator	Agilent	E8267D	US49060192	Oct. 23, 2017	1Year
Vector Signal Generator	Agilent	N5182A	MY48180737	Jun. 16, 2017	1Year
Power Sensor	Agilent	U2021XA	MY55150010	Oct. 21, 2017	1Year
Power Sensor	Agilent	U2021XA	MY55150011	Oct. 23, 2017	1Year
DC Power Source	MATRIS	MPS-3005L-3	D813058W	Aug. 18, 2017	1Year
Attenuator	Mini-Circuits	BW-S10W2	101109	Aug. 18, 2017	1Year
RF Cable	Micable	C10-01-01-1	100309	Oct. 21, 2017	1Year
Temp&Humi Programmable	ZHIXIANG	ZXGDJS-150L	ZX170110-A	Oct. 21, 2017	1Year
Test Software	JS Tonscent	JS1120-3	Ver.2.7	N/A	N/A
USB Data acquisition	Agilent	U2531A	TW55043503	N/A	N/A
Radiated Emission Test 1#					
EMI Test Receiver	R&S	ESU8	100316	Oct. 21, 2017	1 Year
Spectrum analyzer	Agilent	E4447A	MY50180031	Jun. 16, 2017	1 Year
Trilog Broadband Antenna	Schwarzbeck	VULB9163	9163-462	Nov. 09, 2017	1 Year
Active Loop antenna	Schwarzbeck	FMZB-1519	1519-038	Oct. 17, 2017	1 Year
Double Ridged Horn Antenna	R&S	HF907	100276	Oct. 17, 2017	1 Year
Broad Band Horn Antenna	Schwarzbeck	BBHA 9170	790	Nov. 09, 2017	1 Year
Pre-amplifier	TERA-MW	TRLA-0040G35	101303	Oct. 21, 2017	1 Year
Preamplifier	A.H.Systems.lnc	PAM-0118	360	Oct. 21, 2017	1 Year
RF Cable a	HUBSER	CP-X2	W11.03	Oct. 21, 2017	1 Year
RF Cable b	HUBSER	CP-X1	W12.02	Oct. 21, 2017	1 Year
RF Cable	HUBSER	C10-01-01-1M	1091629	Oct. 21, 2017	1 Year
Test software	Audix	E3	V 6.11111b	N/A	N/A
Power Line Conducted Emissions Test					
Test Receiver	R&S	ESPI	101761	Oct. 21, 2017	1 Year
LISN 1	R&S	ENV216	101109	Oct. 21, 2017	1 Year
LISN 2	R&S	ESH2-Z5	100309	Oct. 21, 2017	1 Year
Pulse Limiter	R&S	ESH3-Z2	101242	Oct. 21, 2017	1 Year
CE Cable 1	HUBSER	N/A	W10.01	Oct. 21, 2017	1 Year
Test software	Audix	E3	V 6.11111b	N/A	N/A

4 20dB Bandwidth

4.1. Block diagram of test setup

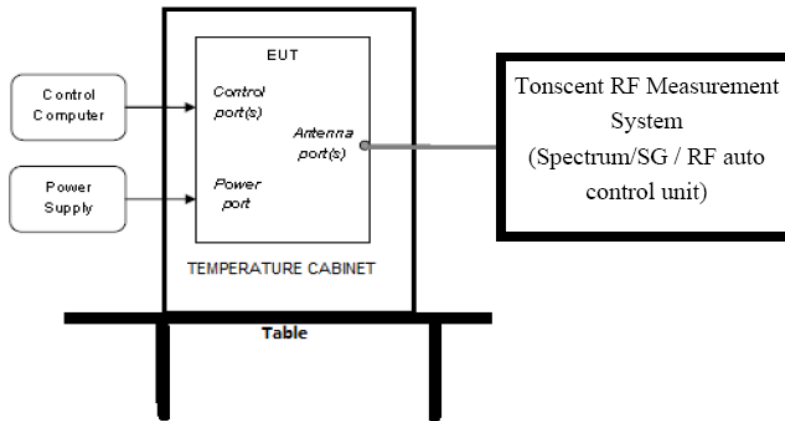

4.2. Limits

Intentional radiators operating under the alternative provisions to the general emission limits, as contained in § 15.217 through 15.257 and in Subpart E of this part, must be designed to ensure that the 20 dB bandwidth of the emission, or whatever bandwidth may otherwise be specified in the specific rule section under which the equipment operates, is contained within the frequency band designated in the rule section under which the equipment is operated.

4.3. Test Procedure

- (1) Connect EUT's antenna output to spectrum analyzer by RF cable.
- (2) The bandwidth of the fundamental frequency was measured by spectrum analyzer with 300 Hz RBW and 1 kHz VBW. The 20dB bandwidth is defined as the total spectrum the power of which is higher than peak power minus 20dB.

4.4. Test Result

Freq. (kHz)	20dB bandwidth Result (kHz)	Conclusion
175	0.865	PASS

4.5. Original test data

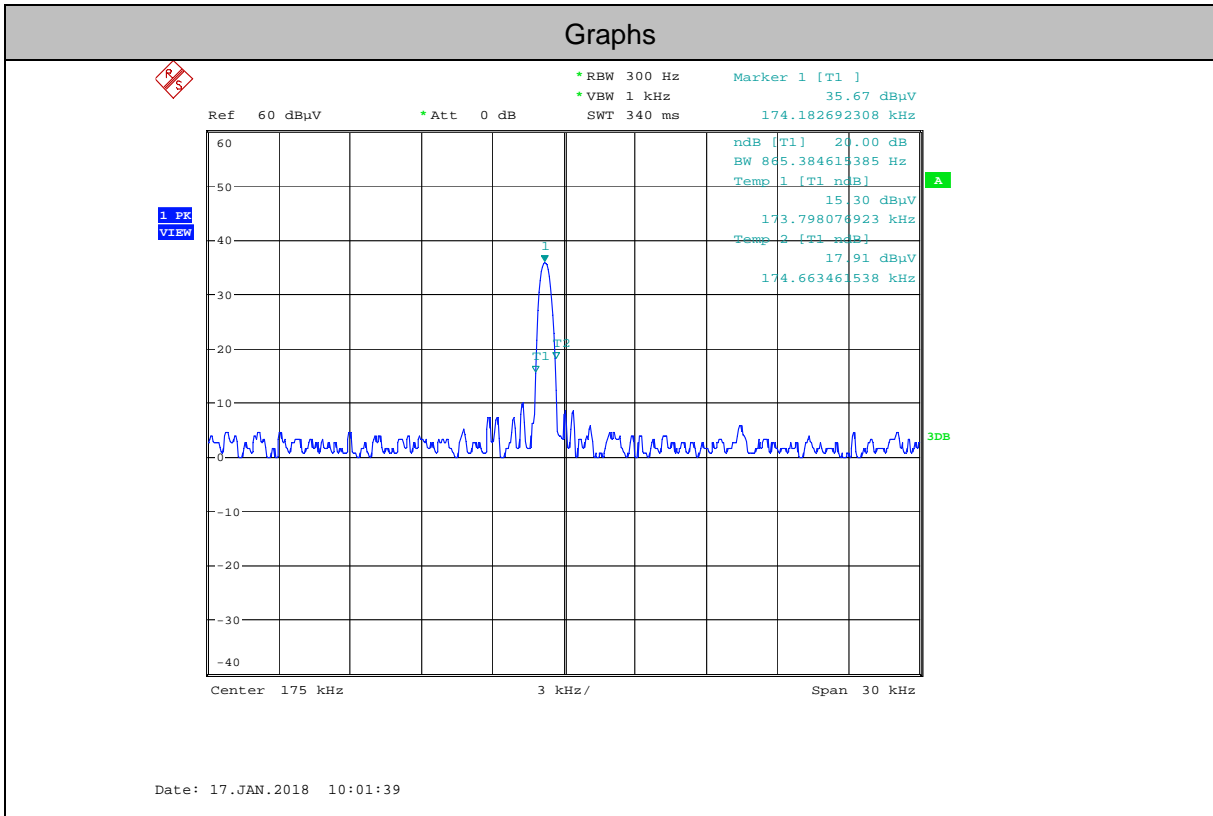

5 Radiated emission

5.1. Block diagram of test setup

In 3m Anechoic Chamber Test Setup Diagram for 9kHz~30MHz

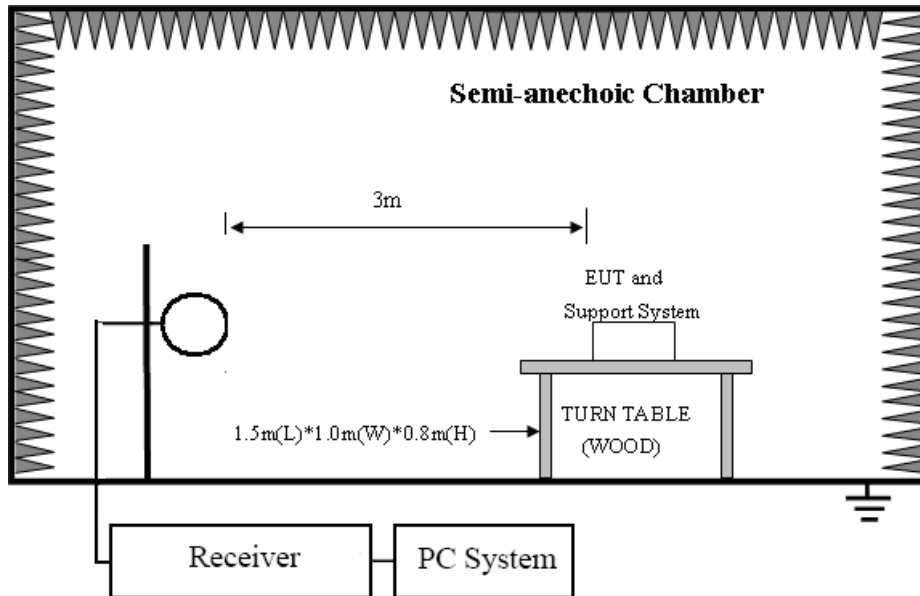

In 3m Anechoic Chamber Test Setup Diagram for 30MHz~1GHz

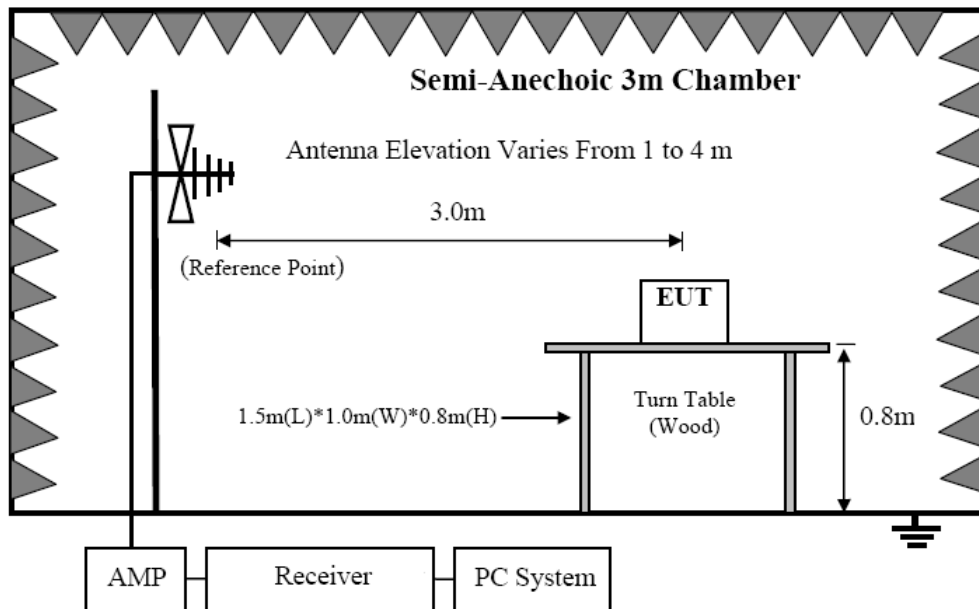

5.2. Limit

FREQUENCY MHz	DISTANCE Meters	FIELD STRENGTHS LIMIT	
		$\mu\text{V}/\text{m}$	$\text{dB}(\mu\text{V})/\text{m}$
0.009 ~ 0.490	300	2400/F(kHz)	67.6-20log(F)
0.490 ~ 1.705	30	24000/F(kHz)	87.6-20log(F)
1.705 ~ 30.0	30	30	29.54
30 ~ 88	3	100	40.0
88 ~ 216	3	150	43.5
216 ~ 960	3	200	46.0
960 ~ 1000	3	500	54.0

Note: (1) The emission limits shown in the above table are based on measurements employing a CISPR QP detector except for the frequency bands 9-90kHz, 110-490kHz and above 1000MHz. Radiated emissions limits in these three bands are based on measurements employing an average detector.

(2) At frequencies below 30MHz, measurement may be performed at a distance closer than that specified, and the limit at closer measurement distance can be extrapolated by below formula:

$$\text{Limit}_{3\text{m}}(\text{dBuV}/\text{m}) = \text{Limit}_{300\text{m}}(\text{dBuV}/\text{m}) + 40\text{Log}(300\text{m}/3\text{m}) = \text{Limit}_{300\text{m}}(\text{dBuV}/\text{m}) + 80$$

$$\text{Limit}_{3\text{m}}(\text{dBuV}/\text{m}) = \text{Limit}_{30\text{m}}(\text{dBuV}/\text{m}) + 40\text{Log}(30\text{m}/3\text{m}) = \text{Limit}_{30\text{m}}(\text{dBuV}/\text{m}) + 40$$

5.3. Test Procedure

- (1) EUT was placed on a non-metallic table, 150 cm above the ground plane inside a semi-anechoic chamber.
- (2) Test antenna was located 3m from the EUT on an adjustable mast, and the antenna used as below table.

Test frequency range	Test antenna used	Test antenna distance
9kHz-30MHz	Active Loop antenna	3m
30MHz-1GHz	Trilog Broadband Antenna	3m

According ANSI C63.10:2013 clause 6.4.4.2 and 6.5.3, for measurements below 30 MHz, the loop antenna was positioned with its plane vertical from the EUT and rotated about its vertical axis for maximum response at each azimuth position around the EUT. And the loop antenna also be positioned with its plane horizontal at the specified distance from the EUT. The center of the loop is 1 m above the ground. for measurement above 30MHz, the Trilog Broadband Antenna or Horn Antenna was located 3m from EUT, Measurements were made with the antenna positioned in both the horizontal and vertical planes of Polarization, and the measurement antenna was varied from 1 m to 4 m. in height above the reference ground plane to obtain the maximum signal strength.

(3) Below pre-scan procedure was first performed in order to find prominent frequency spectrum radiated emissions from 9kHz to 1GHz:

- (a) Scanning the peak frequency spectrum with the antenna specified in step (3), and the

EUT was rotated 360 degree, the antenna height was varied from 1m to 4m(Except loop antenna, it's fixed 1m above ground.)

(b) Change work frequency or channel of device if practicable.

(c) Change modulation type of device if practicable.

(d) Rotated EUT though three orthogonal axes to determine the attitude of EUT arrangement produces highest emissions. Spectrum frequency from 9kHz to 1GHz (tenth harmonic of fundamental frequency) was investigated.

(4) For final emissions measurements at each frequency of interest, the EUT was rotated and the antenna height was varied between 1m and 4m in order to maximize the emission. Measurements in both horizontal and vertical polarities were made and the data was recorded. In order to find the maximum emission, the relative positions of equipments and all of the interface cables were changed according to ANSI C63.10 2013 on Radiated Emission test.

(5) The emissions from 9kHz to 1GHz were measured based on CISPR QP detector except for the frequency bands 9-90kHz, 110-490kHz, for emissions from 9kHz-90kHz,110kHz-490kHz and above 1GHz were measured based on average detector, for emissions above 1GHz, peak emissions also be measured and need comply with Peak limit.

(6) The emissions from 9kHz to 1GHz, QP or average values were measured with EMI receiver with below RBW.

Frequency band	RBW
9kHz-150kHz	200Hz
150kHz-30MHz	9kHz
30MHz-1GHz	120kHz

5.4. Test result

PASS. (See below detailed test result)

Below 30MHz:

Frequency (MHz)	Result @3m (dBuV/m)	Limit @3m (dBuV/m)	Detector	Conclusion
0.040	58.68	135.56	Peak	PASS
0.040	52.23	115.56	Average	PASS
0.110	66.99	126.78	Peak	PASS
0.110	60.64	106.78	Average	PASS
0.175	97.81	122.74	Peak	PASS
0.175	91.54	102.74	Average	PASS
0.520	69.63	73.28	QP	PASS
3.360	65.17	69.54	QP	PASS
14.110	49.14	69.54	QP	PASS

Above 30MHz:

TR-4-E-009 Radiated Emission Test Result

Test Site : DDT 3m Chamber 1# **D:\2017 RE1# Report Data\Q17122905-1E\RE.EM6**
Test Date : 2018-01-23 **Tested By** : Xian
EUT : wireless charger **Model Number** : ES300A
Power Supply : AC 120V/60Hz **Test Mode** : TX mode
Condition : Temp:24.5°C,Humi:55%,
 Press:100.1kPa **Antenna/Distance** : 2017 VULB 9163 1#/3m/HORIZONTAL
Memo :

Data: 8

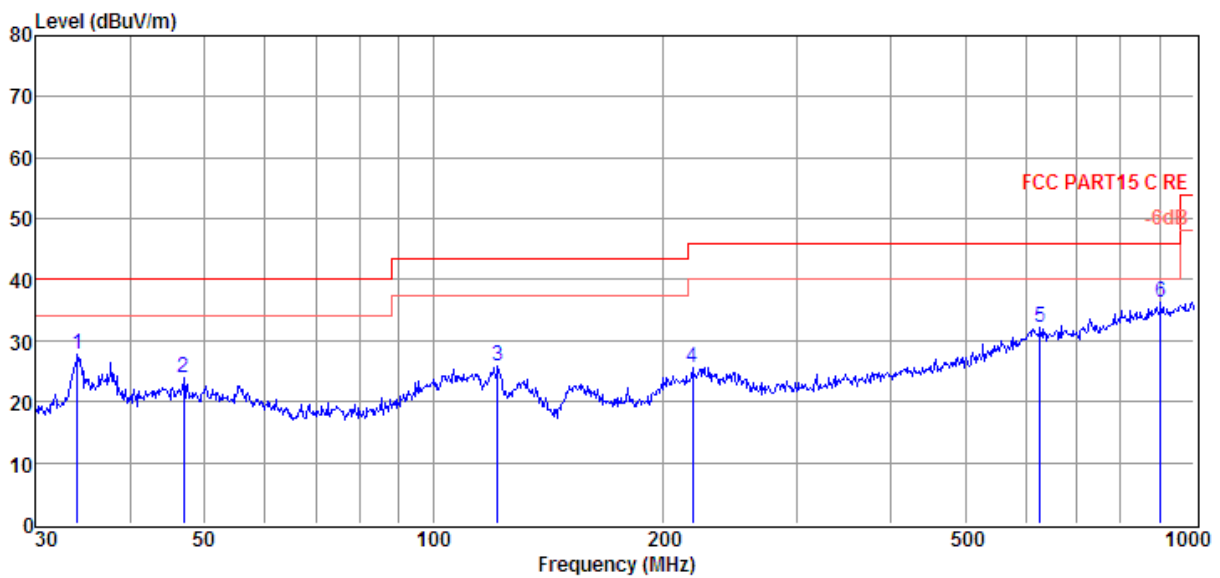

Item (Mark)	Freq. (MHz)	Read Level (dBuV)	Antenna Factor (dB/m)	Cable Loss (dB)	Result Level (dBuV/m)	Limit Line (dBuV/m)	Over Limit (dB)	Detector	Polarization
1	34.04	12.70	11.37	3.82	27.89	40.00	-12.11	Peak	HORIZONTAL
2	47.00	6.49	13.47	3.96	23.92	40.00	-16.08	Peak	HORIZONTAL
3	121.55	12.10	9.05	4.58	25.73	43.50	-17.77	Peak	HORIZONTAL
4	219.08	8.46	11.90	5.13	25.49	46.00	-20.51	Peak	HORIZONTAL
5	627.27	5.85	19.49	6.77	32.11	46.00	-13.89	Peak	HORIZONTAL
6	903.31	6.02	22.59	7.61	36.22	46.00	-9.78	Peak	HORIZONTAL

Note: 1. Result Level = Read Level + Antenna Factor + Cable loss.
 2. If Peak Result complies with QP limit, QP Result is deemed to comply with QP limit.
 3. Test setup: RBW: 120 kHz, VBW: 300 kHz, Sweep time: auto.

TR-4-E-009 Radiated Emission Test Result

Test Site : DDT 3m Chamber 1# **D:\2017 RE1# Report Data\Q17122905-1E\RE.EM6**
Test Date : 2018-01-23 **Tested By** : Xian
EUT : wireless charger **Model Number** : ES300A
Power Supply : AC 120V/60Hz **Test Mode** : TX mode
Condition : Temp:24.5°C,Humi:55%,
 Press:100.1kPa **Antenna/Distance** : 2017 VULB 9163 1#/3m/VERTICAL
Memo :

Data: 7

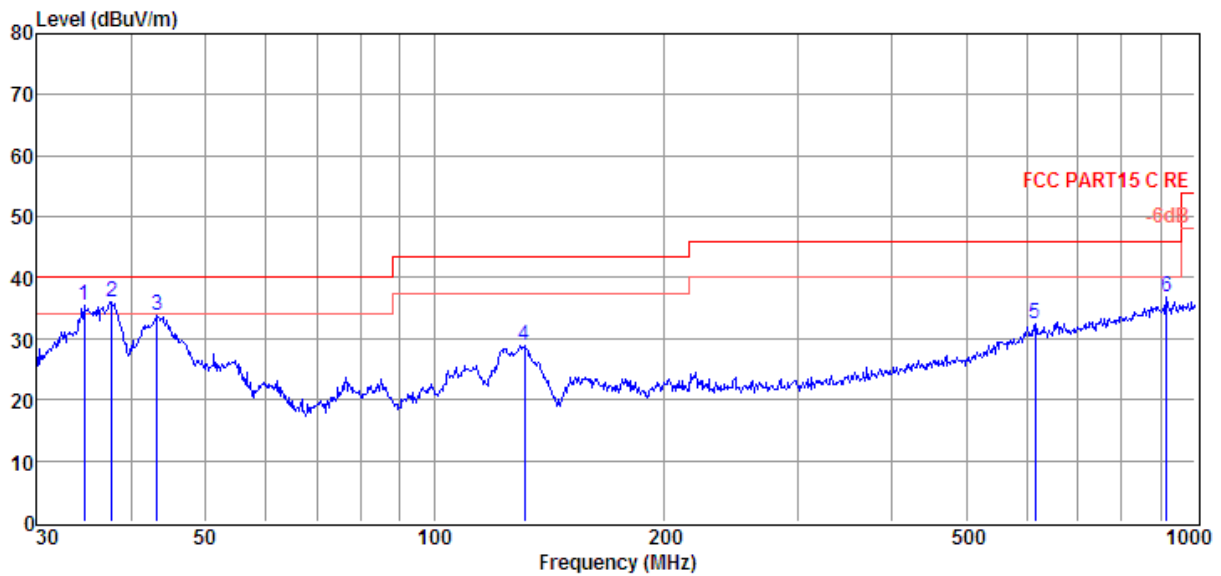

Item (Mark)	Freq. (MHz)	Read Level (dBμV)	Antenna Factor (dB/m)	Cable Loss (dB)	Result Level (dBμV/m)	Limit Line (dBμV/m)	Over Limit (dB)	Detector	Polarization
1	34.64	20.14	11.50	3.82	35.46	40.00	-4.54	Peak	VERTICAL
2	37.68	19.93	12.14	3.85	35.92	40.00	-4.08	Peak	VERTICAL
3	43.20	16.81	13.01	3.91	33.73	40.00	-6.27	Peak	VERTICAL
4	131.30	16.18	8.15	4.65	28.98	43.50	-14.52	Peak	VERTICAL
5	616.37	6.40	19.45	6.73	32.58	46.00	-13.42	Peak	VERTICAL
6	916.07	6.60	22.57	7.65	36.82	46.00	-9.18	Peak	VERTICAL

Note: 1. Result Level = Read Level + Antenna Factor + Cable loss.
 2. If Peak Result complies with QP limit, QP Result is deemed to comply with QP limit.
 3. Test setup: RBW: 120 kHz, VBW: 300 kHz, Sweep time: auto.

6 Power Line Conducted Emission

6.1. Block diagram of test setup

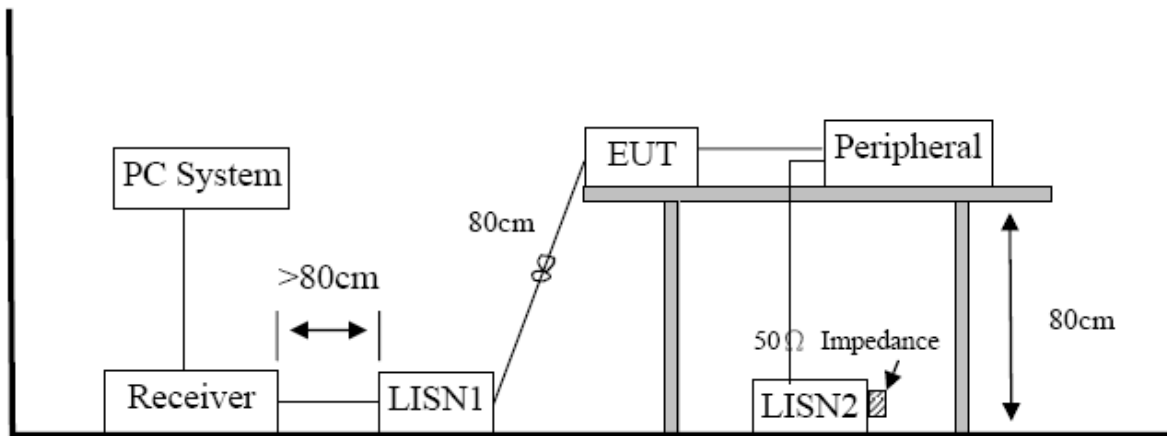

6.2. Power Line Conducted Emission Limits

Frequency	Quasi-Peak Level dB(μ V)	Average Level dB(μ V)
150kHz ~ 500kHz	66 ~ 56*	56 ~ 46*
500kHz ~ 5MHz	56	46
5MHz ~ 30MHz	60	50

Note 1: * Decreasing linearly with logarithm of frequency.

Note 2: The lower limit shall apply at the transition frequencies.

6.3. Test Procedure

The EUT and Support equipment, if needed, were put placed on a non-metallic table, 80cm above the ground plane.

Configuration EUT to simulate typical usage as described in clause 2.4 and test equipment as described in clause 10.2 of this report.

All I/O cables were positioned to simulate typical actual usage as per ANSI C63.10.

All support equipment power received from a second LISN.

Emissions were measured on each current carrying line of the EUT using an EMI Test Receiver connected to the LISN powering the EUT.

The Receiver scanned from 150 kHz to 30MHz for emissions in each of the test modes.

During the above scans, the emissions were maximized by cable manipulation.

The test mode(s) described in clause 2.4 were scanned during the preliminary test.

After the preliminary scan, we found the test mode producing the highest emission level.

The EUT configuration and worse cable configuration of the above highest emission levels were recorded for reference of the final test.

EUT and support equipment were set up on the test bench as per the configuration with highest emission level in the preliminary test.

A scan was taken on both power lines, Neutral and Line, recording at least the six highest emissions.

Emission frequency and amplitude were recorded into a computer in which correction factors were used to calculate the emission level and compare reading to the applicable limit.

The test data of the worst-case condition(s) was recorded.

The bandwidth of test receiver is set at 9 kHz.

6.4. Test Result

PASS. (See below detailed test result)

Note1: All emissions not reported below are too low against the prescribed limits.

Note2: "----" means Peak detection; "----" means Average detection.

Note3: Pre-test AC conducted emission at both voltage AC 120V/60Hz and AC 240V/50Hz, recorded worst case (AC 120V/60Hz).

TR-4-E-010 Conducted Emission Test Result

Test Site : DDT 1# Shield Room E:\2017 CE report data\Q17122905-3E\CE.EM6
Test Date : 2018-01-23 **Tested By** : Sunny
EUT : wireless charger **Model Number** : ES300A
Power Supply : AC 120V/60Hz **Test Mode** : TX mode
Condition : Temp:24.5°C,Humi:55%,
 Press:100.1kPa **LISN** : 2017 ENV216/NEUTRAL
Memo :

Data: 2

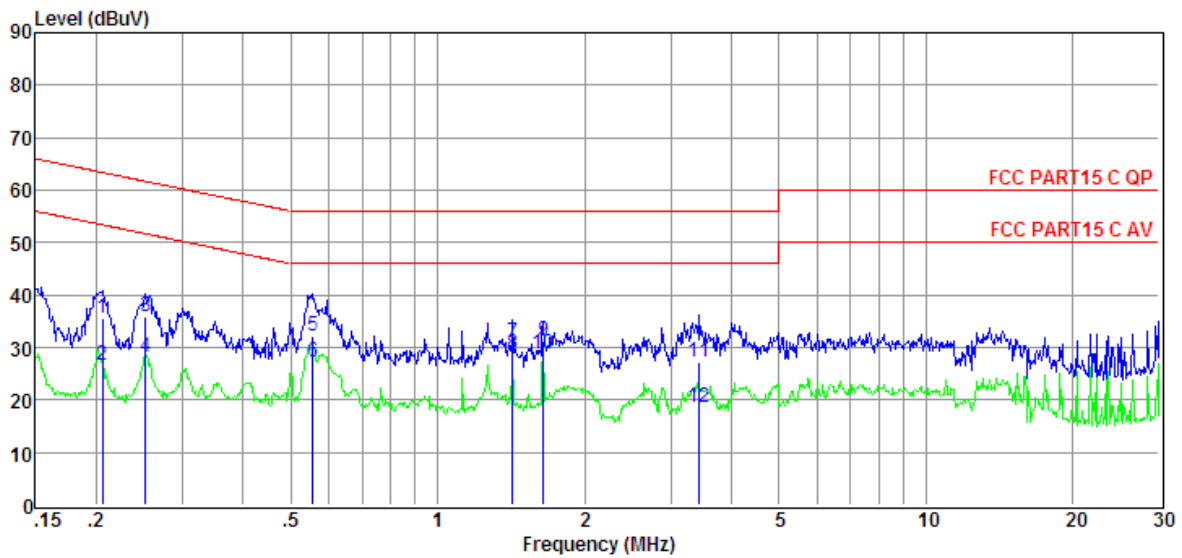

Item (Mark)	Freq. (MHz)	Read Level (dBµV)	LISN Factor (dB)	Cable Loss (dB)	Pulse Limiter Factor (dB)	Result Level (dBµV)	Limit Line (dBµV)	Over Limit (dB)	Detector	Phase
1	0.21	16.35	9.45	0.04	9.86	35.70	63.36	-27.66	QP	NEUTRAL
2	0.21	7.38	9.45	0.04	9.86	26.73	53.36	-26.63	Average	NEUTRAL
3	0.25	16.54	9.42	0.04	9.86	35.86	61.69	-25.83	QP	NEUTRAL
4	0.25	8.72	9.42	0.04	9.86	28.04	51.69	-23.65	Average	NEUTRAL
5	0.56	13.04	9.34	0.06	9.82	32.26	56.00	-23.74	QP	NEUTRAL
6	0.56	8.14	9.34	0.06	9.82	27.36	46.00	-18.64	Average	NEUTRAL
7	1.43	11.69	9.28	0.13	9.86	30.96	56.00	-25.04	QP	NEUTRAL
8	1.43	9.57	9.28	0.13	9.86	28.84	46.00	-17.16	Average	NEUTRAL
9	1.65	11.81	9.28	0.13	9.86	31.08	56.00	-24.92	QP	NEUTRAL
10	1.65	9.49	9.28	0.13	9.86	28.76	46.00	-17.24	Average	NEUTRAL
11	3.44	7.93	9.27	0.11	9.87	27.18	56.00	-28.82	QP	NEUTRAL
12	3.44	-0.62	9.27	0.11	9.87	18.63	46.00	-27.37	Average	NEUTRAL

- Note: 1. Result Level = Read Level + LISN Factor + Pulse Limiter Factor + Cable loss.
 2. If QP Result complies with AV limit, AV Result is deemed to comply with AV limit.
 3. Test setup: RBW: 200 Hz (9 kHz—150 kHz), 9 kHz (150 kHz—30 MHz).
 4. Step size: 80Hz (0.009MHz-0.15MHz), 4 kHz (0.15MHz-30MHz), Scan time: auto.

TR-4-E-010 Conducted Emission Test Result

Test Site : DDT 1# Shield Room E:\2017 CE report data\Q17122905-3E\CE.EM6
Test Date : 2018-01-23 **Tested By** : Sunny
EUT : wireless charger **Model Number** : ES300A
Power Supply : AC 120V/60Hz **Test Mode** : TX mode
Condition : Temp:24.5°C,Humi:55%,
LISN : 2017 ENV216/LINE
 Press:100.1kPa
Memo :

Data: 4

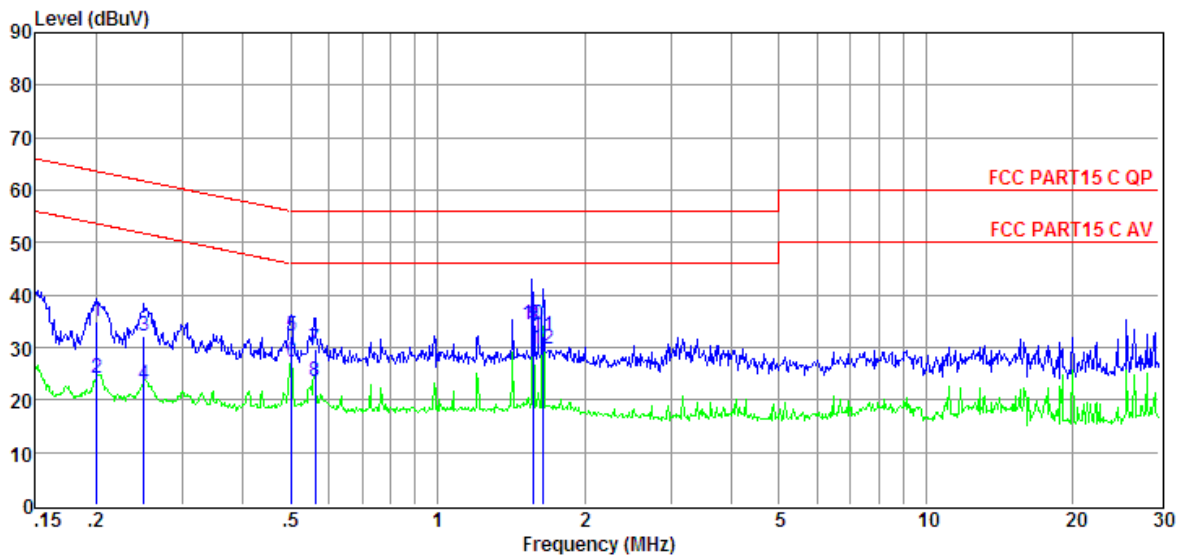

Item (Mark)	Freq. (MHz)	Read Level (dBμV)	LISN Factor (dB)	Cable Loss (dB)	Pulse Limiter Factor (dB)	Result Level (dBμV)	Limit Line (dBμV)	Over Limit (dB)	Detector	Phase
1	0.20	15.56	9.51	0.04	9.86	34.97	63.58	-28.61	QP	LINE
2	0.20	4.63	9.51	0.04	9.86	24.04	53.58	-29.54	Average	LINE
3	0.25	12.66	9.52	0.04	9.86	32.08	61.73	-29.65	QP	LINE
4	0.25	3.45	9.52	0.04	9.86	22.87	51.73	-28.86	Average	LINE
5	0.50	12.80	9.54	0.04	9.80	32.18	56.00	-23.82	QP	LINE
6	0.50	7.69	9.54	0.04	9.80	27.07	46.00	-18.93	Average	LINE
7	0.56	10.37	9.55	0.06	9.82	29.80	56.00	-26.20	QP	LINE
8	0.56	4.09	9.55	0.06	9.82	23.52	46.00	-22.48	Average	LINE
9	1.57	14.70	9.59	0.13	9.86	34.28	56.00	-21.72	QP	LINE
10	1.65	12.71	9.59	0.13	9.86	32.29	56.00	-23.71	QP	LINE
11	1.65	10.21	9.59	0.13	9.86	29.79	46.00	-16.21	Average	LINE

- Note: 1. Result Level = Read Level + LISN Factor + Pulse Limiter Factor + Cable loss.
 2. If QP Result complies with AV limit, AV Result is deemed to comply with AV limit.
 3. Test setup: RBW: 200 Hz (9 kHz—150 kHz), 9 kHz (150 kHz—30 MHz).
 4. Step size: 80Hz (0.009MHz-0.15MHz), 4 kHz (0.15MHz-30MHz), Scan time: auto.

7 Antenna Requirements

For intentional device, according to FCC 47 CFR Section 15.203, An intentional radiator shall be designed to ensure that no antenna other than that furnished by the responsible party shall be used with the device. The use of a permanently attached antenna or of an antenna that uses a unique coupling to the intentional radiator shall be considered sufficient to comply with the provisions of this section. The manufacturer may design the unit so that a broken antenna can be replaced by the user, but the use of a standard antenna jack or electrical connector is prohibited.



END OF REPORT