

# FCC CERTIFICATION TEST REPORT

## FOR

<b>Applicant</b>	:	SHENZHEN EPQI TECHNOLOGY CO., LTD
<b>Address</b>	:	Floor 6, Block 7, Zhongyuntai Industry Park, Songbai Road, Shiyan Town, Bao'an District, Shenzhen, China.
<b>Equipment under Test</b>	:	wireless charger
<b>Model No.</b>	:	EC500F, EC500A, EC500B, EC500C, EC500D, EC500E, EC500G, EC500H, EC500I, EC500J, EC500K, EC500M
<b>Trade Mark</b>	:	EPQI
<b>FCC ID</b>	:	2AOPC-EC500F
<b>Manufacturer</b>	:	SHENZHEN EPQI TECHNOLOGY CO., LTD
<b>Address</b>	:	Floor 6, Block 7, Zhongyuntai Industry Park, Songbai Road, Shiyan Town, Bao'an District, Shenzhen, China.

**Issued By: Dongguan Dongdian Testing Service Co., Ltd.**

**Add:** No. 17, Zongbu Road 2, Songshan Lake Sci&Tech, Industry Park, Dongguan  
City, Guangdong Province, China, 523808

**Tel:** +86-0769-89201699, **E-mail:** ddt@dgdtd.com, <http://www.dgdtd.com>

# REPORT

## TABLE OF CONTENTS

	Test report declares.....	3
1	Summary of test results .....	4
2	General test information .....	5
2.1.	Description of EUT .....	5
2.2.	Accessories of EUT.....	5
2.3.	Assistant equipment used for test.....	5
2.4.	Block diagram of EUT configuration for test.....	5
2.5.	Deviations of test standard.....	5
2.6.	Test environment conditions .....	6
2.7.	Test laboratory .....	6
2.8.	Measurement uncertainty .....	6
3	Equipment used during test .....	7
4	20dB Bandwidth.....	8
4.1.	Block diagram of test setup.....	8
4.2.	Limits .....	8
4.3.	Test Procedure.....	8
4.4.	Test Result.....	8
4.5.	Original test data.....	9
5	Radiated emission .....	10
5.1.	Block diagram of test setup.....	10
5.2.	Limit .....	11
5.3.	Test Procedure.....	11
5.4.	Test result .....	12
6	Power Line Conducted Emission .....	15
6.1.	Block diagram of test setup.....	15
6.2.	Power Line Conducted Emission Limits.....	15
6.3.	Test Procedure.....	15
6.4.	Test Result.....	16
7	Antenna Requirements .....	19

## TEST REPORT DECLARE

<b>Applicant</b>	:	SHENZHEN EPQI TECHNOLOGY CO., LTD
<b>Address</b>	:	Floor 6, Block 7, Zhongyuntai Industry Park, Songbai Road, Shiyan Town, Bao'an District, Shenzhen, China.
<b>Equipment under Test</b>	:	wireless charger
<b>Model No.</b>	:	EC500F, EC500A, EC500B, EC500C, EC500D, EC500E, EC500G, EC500H, EC500I, EC500J, EC500K, EC500M
<b>Trade Mark</b>	:	EPQI
<b>Manufacturer</b>	:	SHENZHEN EPQI TECHNOLOGY CO., LTD
<b>Address</b>	:	Floor 6, Block 7, Zhongyuntai Industry Park, Songbai Road, Shiyan Town, Bao'an District, Shenzhen, China.

**Test Standard Used:**

FCC Rules and Regulations Part 15 Subpart C

**Test procedure used:**

ANSI C63.10:2013

**We Declare:**

The equipment described above is tested by Dongguan Dongdian Testing Service Co., Ltd and in the configuration tested the equipment complied with the standards specified above. The test results are contained in this test report and Dongguan Dongdian Testing Service Co., Ltd is assumed of full responsibility for the accuracy and completeness of these tests.

**After test and evaluation, our opinion is that the equipment provided for test compliance with the requirement of the above FCC standards.**

<b>Report No:</b>	DDT-R18040406-1E2		
<b>Date of Test:</b>	Apr. 08, 2018~Apr. 19, 2018	<b>Date of Report:</b>	Apr. 19, 2018

**Prepared By:**

*Sam Li*

**Sam Li/Engineer**

**Approved By:**



**Kevin Feng/EMC Manager**

Note: This report applies to above tested sample only. This report shall not be reproduced in parts without written approval of Dongguan Dongdian Testing Service Co., Ltd.

**1 Summary of test results**

<b>Description of Test Item</b>	<b>Standard</b>	<b>Results</b>
20dB Bandwidth	FCC Part 15: 15.215	PASS
Radiated Emission	FCC Part 15: 15.209	PASS
Power Line Conducted Emissions	FCC Part 15: 15.207	PASS
Antenna requirement	FCC Part 15: 15.203	PASS

## 2 General test information

### 2.1. Description of EUT

EUT* Name	:	wireless charger
Model Number	:	EC500F, EC500A, EC500B, EC500C, EC500D, EC500E, EC500G, EC500H, EC500I, EC500J, EC500K, EC500M
Difference of model number	:	All models are identical, except the model number and colors, all tests are performed on model EC500F.
EUT function description	:	Please reference user manual of this device
Power supply	:	DC 9V from external AC Adapter
Wireless charging Operation frequency	:	120kHz-210kHz
Antenna Type	:	Inductive loop coil antenna
Sample Type	:	Series production

Note: EUT is the ab. of equipment under test.

### 2.2. Accessories of EUT

Description of Accessories	Manufacturer	Model number or Type	Serial No.	Other
/	/	/	/	/

### 2.3. Assistant equipment used for test

Assistant equipment	Manufacturer	Model number or Type	EMC Compliance	Other
Simulation load	/	/	/	/
USB cable	/	/	/	/
AC adapter	HUAWEI	HW-050200C3 W	/	Input: AC 100-240V 50/60Hz 0.5A MAX Output: DC 5.0V 2A

### 2.4. Block diagram of EUT configuration for test

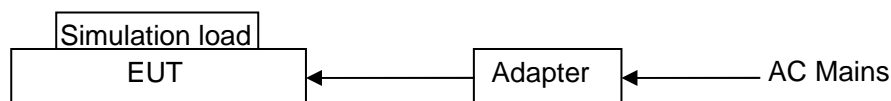

### 2.5. Deviations of test standard

No Deviation.

## 2.6. Test environment conditions

During the measurement the environmental conditions were within the listed ranges:

Temperature range:	21-25°C
Humidity range:	40-75%
Pressure range:	86-106kPa

## 2.7. Test laboratory

Dongguan Dongdian Testing Service Co., Ltd

Add: No. 17, Zongbu Road 2, Songshan Lake Sci&Tech, Industry Park, Dongguan City, Guangdong Province, China, 523808

Tel: +86-0769-89201699, E-mail: ddt@dgddt.com, <http://www.dgddt.com>

FCC Registration Number: 270092; Industry Canada site registration number: 10288A-1

## 2.8. Measurement uncertainty

Test Item	Uncertainty
Uncertainty for Conduction emission test	3.32dB (150kHz-30MHz)
	3.72dB (9kHz-150kHz)
Uncertainty for Radiation Emission test (30MHz-1GHz)	4.70 dB (Antenna Polarize: V)
	4.84 dB (Antenna Polarize: H)
Uncertainty for Radiation Emission test (1GHz to 18GHz)	4.10dB(1-6GHz)
	4.40dB (6GHz-18GHz)
Bandwidth	1.1%
Note: This uncertainty represents an expanded uncertainty expressed at approximately the 95% confidence level using a coverage factor of k=2.	

### 3 Equipment used during test

Equipment	Manufacturer	Model No.	Serial No.	Last Cal.	Cal. Interval
<b>RF Connected Test</b>					
Spectrum analyzer	R&S	FSU26	200071	Oct. 23, 2017	1 Year
Wideband Radio Communication tester	R&S	CMW500	117491	Jun. 16, 2017	1 Year
Vector Signal Generator	Agilent	E8267D	US49060192	Oct. 23, 2017	1 Year
Vector Signal Generator	Agilent	N5182A	MY48180737	Jun. 16, 2017	1 Year
Power Sensor	Agilent	U2021XA	MY55150010	Oct. 21, 2017	1 Year
Power Sensor	Agilent	U2021XA	MY55150011	Oct. 23, 2017	1 Year
DC Power Source	MATRIS	MPS-3005L-3	D813058W	Aug. 18, 2017	1 Year
Attenuator	Mini-Circuits	BW-S10W2	101109	Aug. 18, 2017	1 Year
RF Cable	Micable	C10-01-01-1	100309	Oct. 21, 2017	1 Year
Temp&Humi Programmable	ZHIXIANG	ZXGDJS-150L	ZX170110-A	Oct. 21, 2017	1 Year
Test Software	JS Tonscent	JS1120-3	Ver.2.7	N/A	N/A
<b>Radiated Emission Test 1#</b>					
EMI Test Receiver	R&S	ESU8	100316	Oct. 21, 2017	1 Year
Spectrum analyzer	Agilent	E4447A	MY50180031	Jun. 16, 2017	1 Year
Trilog Broadband Antenna	Schwarzbeck	VULB9163	9163-462	Nov. 09, 2017	1 Year
Active Loop antenna	Schwarzbeck	FMZB-1519	1519-038	Oct. 17, 2017	1 Year
Double Ridged Horn Antenna	R&S	HF907	100276	Oct. 17, 2017	1 Year
Broad Band Horn Antenna	Schwarzbeck	BBHA 9170	790	Nov. 09, 2017	1 Year
Pre-amplifier	TERA-MW	TRLA-0040G35	101303	Oct. 21, 2017	1 Year
Preamplifier	A.H.Systems.lnc	PAM-0118	360	Oct. 21, 2017	1 Year
RF Cable	HUBSER	CP-X2+ CP-X1	W11.03+ W12.02	Oct. 21, 2017	1 Year
RF Cable	N/A	SMAJ-SMAJ-1M+ 11M	17070133+17070131	Nov. 08, 2017	1 Year
MI Cable	HUBSER	C10-01-01-1M	1091629	Oct. 21, 2017	1 Year
Test software	Audix	E3	V 6.11111b	N/A	N/A
<b>Power Line Conducted Emissions Test</b>					
Test Receiver	R&S	ESPI	101761	Oct. 21, 2017	1 Year
LISN 1	R&S	ENV216	101109	Oct. 21, 2017	1 Year
LISN 2	R&S	ESH2-Z5	100309	Oct. 21, 2017	1 Year
Pulse Limiter	R&S	ESH3-Z2	101242	Oct. 21, 2017	1 Year
CE Cable 1	HUBSER	N/A	W10.01	Oct. 21, 2017	1 Year
Test software	Audix	E3	V 6.11111b	N/A	N/A

## 4 20dB Bandwidth

### 4.1. Block diagram of test setup

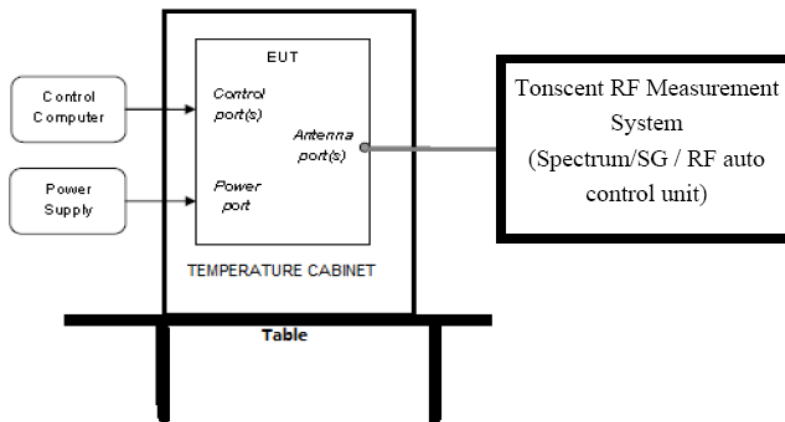

### 4.2. Limits

Intentional radiators operating under the alternative provisions to the general emission limits, as contained in § 15.217 through 15.257 and in Subpart E of this part, must be designed to ensure that the 20 dB bandwidth of the emission, or whatever bandwidth may otherwise be specified in the specific rule section under which the equipment operates, is contained within the frequency band designated in the rule section under which the equipment is operated.

### 4.3. Test Procedure

- (1) Connect EUT's antenna output to spectrum analyzer by RF cable.
- (2) The bandwidth of the fundamental frequency was measured by spectrum analyzer with 300 Hz RBW and 1 kHz VBW. The 20dB bandwidth is defined as the total spectrum the power of which is higher than peak power minus 20dB.

### 4.4. Test Result

Freq. (kHz)	20dB bandwidth Result (kHz)	Conclusion
175	1.525	PASS



### 4.5. Original test data

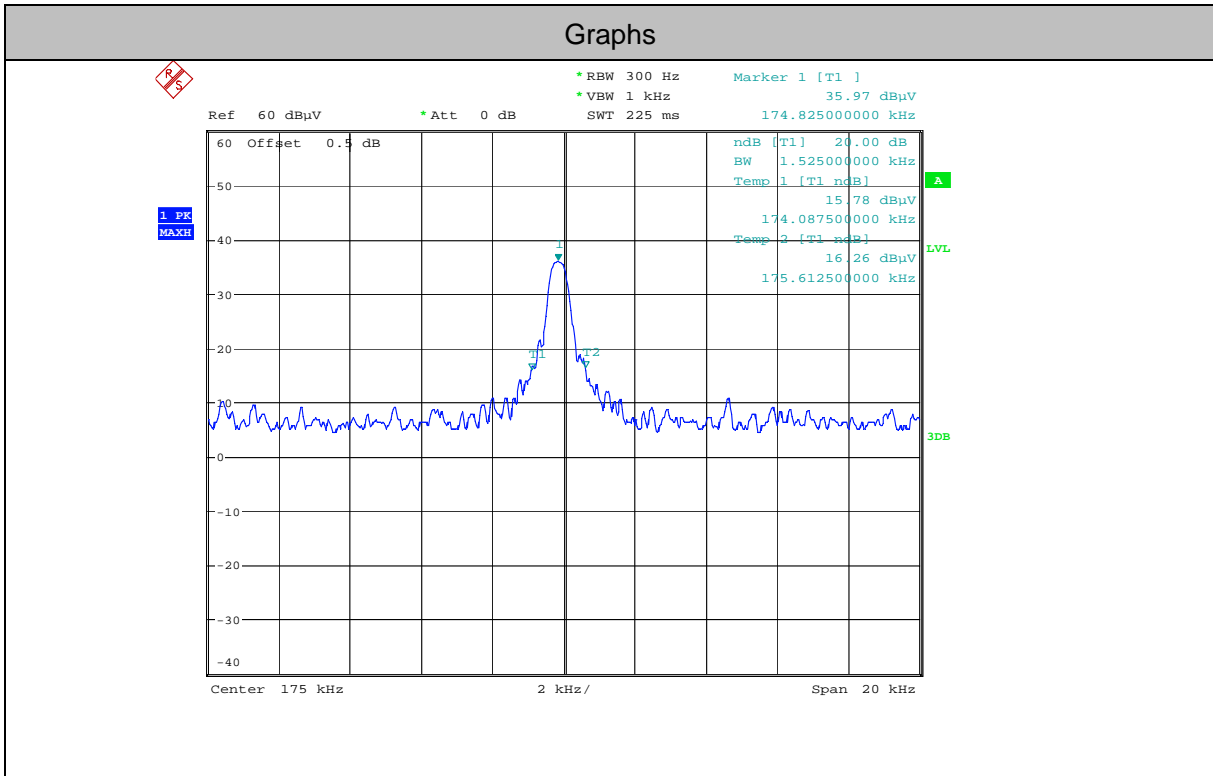

## 5 Radiated emission

### 5.1. Block diagram of test setup

In 3m Anechoic Chamber Test Setup Diagram for 9kHz~30MHz

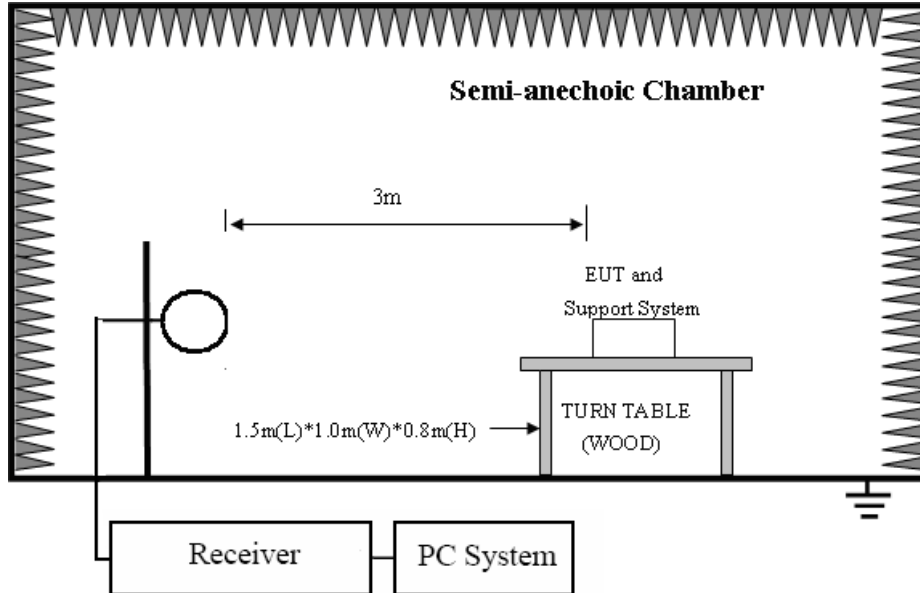

In 3m Anechoic Chamber Test Setup Diagram for 30MHz~1GHz

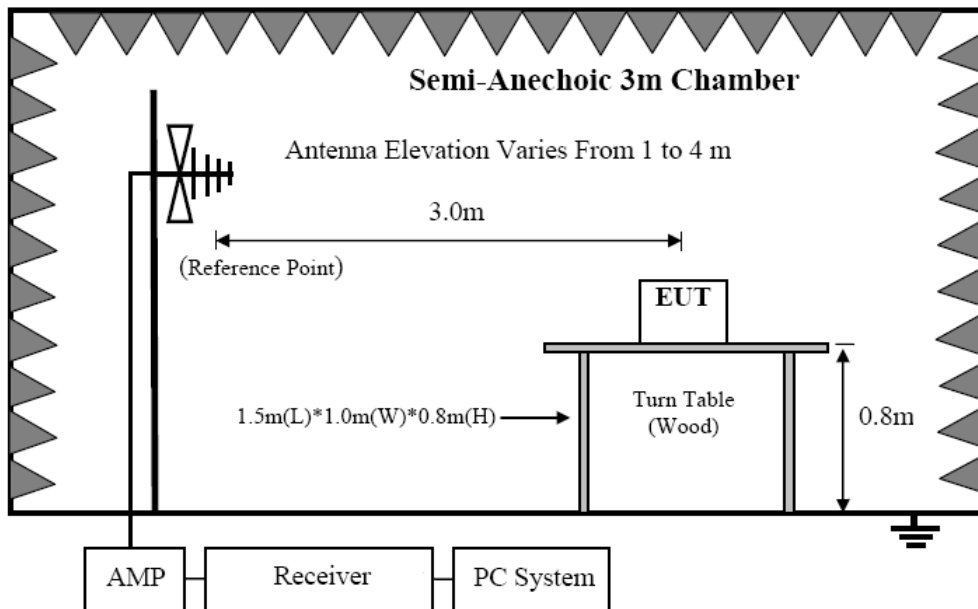

## 5.2. Limit

FREQUENCY MHz	DISTANCE Meters	FIELD STRENGTHS LIMIT	
		$\mu\text{V}/\text{m}$	$\text{dB}(\mu\text{V})/\text{m}$
0.009 ~ 0.490	300	2400/F(kHz)	67.6-20log(F)
0.490 ~ 1.705	30	24000/F(kHz)	87.6-20log(F)
1.705 ~ 30.0	30	30	29.54
30 ~ 88	3	100	40.0
88 ~ 216	3	150	43.5
216 ~ 960	3	200	46.0
960 ~ 1000	3	500	54.0

Note: (1) The emission limits shown in the above table are based on measurements employing a CISPR QP detector except for the frequency bands 9-90kHz, 110-490kHz and above 1000MHz. Radiated emissions limits in these three bands are based on measurements employing an average detector.

(2) At frequencies below 30MHz, measurement may be performed at a distance closer than that specified, and the limit at closer measurement distance can be extrapolated by below formula:

$$\text{Limit}_{3\text{m}}(\text{dBuV}/\text{m}) = \text{Limit}_{300\text{m}}(\text{dBuV}/\text{m}) + 40\text{Log}(300\text{m}/3\text{m}) = \text{Limit}_{300\text{m}}(\text{dBuV}/\text{m}) + 80$$

$$\text{Limit}_{3\text{m}}(\text{dBuV}/\text{m}) = \text{Limit}_{30\text{m}}(\text{dBuV}/\text{m}) + 40\text{Log}(30\text{m}/3\text{m}) = \text{Limit}_{30\text{m}}(\text{dBuV}/\text{m}) + 40$$

## 5.3. Test Procedure

- (1) EUT was placed on a non-metallic table, 150 cm above the ground plane inside a semi-anechoic chamber.
- (2) Test antenna was located 3m from the EUT on an adjustable mast, and the antenna used as below table.

Test frequency range	Test antenna used	Test antenna distance
9kHz-30MHz	Active Loop antenna	3m
30MHz-1GHz	Trilog Broadband Antenna	3m

According ANSI C63.10:2013 clause 6.4.4.2 and 6.5.3, for measurements below 30 MHz, the loop antenna was positioned with its plane vertical from the EUT and rotated about its vertical axis for maximum response at each azimuth position around the EUT. And the loop antenna also be positioned with its plane horizontal at the specified distance from the EUT. The center of the loop is 1 m above the ground. for measurement above 30MHz, the Trilog Broadband Antenna or Horn Antenna was located 3m from EUT, Measurements were made with the antenna positioned in both the horizontal and vertical planes of Polarization, and the measurement antenna was varied from 1 m to 4 m. in height above the reference ground plane to obtain the maximum signal strength.

(3) Below pre-scan procedure was first performed in order to find prominent frequency spectrum radiated emissions from 9kHz to 1GHz:

- (a) Scanning the peak frequency spectrum with the antenna specified in step (3), and the

EUT was rotated 360 degree, the antenna height was varied from 1m to 4m(Except loop antenna, it's fixed 1m above ground.)

(b) Change work frequency or channel of device if practicable.

(c) Change modulation type of device if practicable.

(d) Rotated EUT though three orthogonal axes to determine the attitude of EUT arrangement produces highest emissions. Spectrum frequency from 9kHz to 1GHz (tenth harmonic of fundamental frequency) was investigated.

(4) For final emissions measurements at each frequency of interest, the EUT was rotated and the antenna height was varied between 1m and 4m in order to maximize the emission. Measurements in both horizontal and vertical polarities were made and the data was recorded. In order to find the maximum emission, the relative positions of equipments and all of the interface cables were changed according to ANSI C63.10 2013 on Radiated Emission test.

(5) The emissions from 9kHz to 1GHz were measured based on CISPR QP detector except for the frequency bands 9-90kHz, 110-490kHz, for emissions from 9kHz-90kHz,110kHz-490kHz and above 1GHz were measured based on average detector, for emissions above 1GHz, peak emissions also be measured and need comply with Peak limit.

(6) The emissions from 9kHz to 1GHz, QP or average values were measured with EMI receiver with below RBW.

Frequency band	RBW
9kHz-150kHz	200Hz
150kHz-30MHz	9kHz
30MHz-1GHz	120kHz

#### 5.4. Test result

**PASS. (See below detailed test result)**

##### **Below 30MHz:**

Frequency (MHz)	Result @3m (dBuV/m)	Limit @3m (dBuV/m)	Detector	Conclusion
0.040	54.74	135.56	Peak	PASS
0.040	48.35	115.56	Average	PASS
0.110	49.48	126.78	Peak	PASS
0.110	43.64	106.78	Average	PASS
0.175	89.58	122.74	Peak	PASS
0.175	84.16	102.74	Average	PASS
0.520	68.63	73.28	QP	PASS
1.230	61.25	65.81	QP	PASS
21.94	49.43	69.54	QP	PASS