

KYMCO Many 110 EV

Electric Scooter

User Manual



KYMCO

FCC Statement

This device complies with part 15 of the FCC rules. Operations is subject to the following two conditions: (1) this device may not cause harmful interference and (2) this device must accept any interference received, including interference that may cause undesired operation (15.19)

FCC 15.21:

The changes or modifications not expressly approved by the party responsible for compliance could void the user's authority to operate the equipment.

FCC 15.105

This equipment has been tested and found to comply with the limits for a Class B digital device, pursuant to part 15 of the FCC Rules. These limits are designed to provide reasonable protection against harmful interference in a residential installation. This equipment generates, uses and can radiate radio frequency energy and, if not installed and used in accordance with the instructions, may cause harmful interference to radio communications. However, there is no guarantee that interference will not occur in a particular installation. If this equipment does cause harmful interference to radio or television reception, which can be determined by turning the equipment off and on, the user is encouraged to try to correct the interference by one or more of the following measures:

- Reorient or relocate the receiving antenna.
- Increase the separation between the equipment and receiver.
- Connect the equipment into an outlet on a circuit different from that to which the receiver is connected.
- Consult the dealer or an experienced radio/TV technician for help.

NCC Notice

Administrative Regulations on Low Power Radio Waves Radiated Devices

Article 12 Without permission granted by the NCC, no company, enterprise, or user is allowed to change the frequency, enhance the transmitting power, or alter the original characteristics, as well as performance, of approved low power radio-frequency devices.

Article 14 The low power radio-frequency devices shall not influence aircraft security and interfere with legal communications. If found, the user shall cease operating immediately until no interference is achieved.

The said legal communications means radio communications operated in compliance with the Telecommunications Act. The low power radio-frequency devices must be susceptible with the interference from legal communications or industrial, scientific, medical and ISM radio wave radiated devices.

NCC Label Information

noodoe NCC



NFC NCC

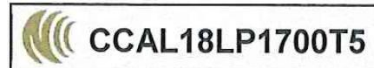

Dear User,

Thank you very much for choosing a KYMCO NEW Many 110 EV Scooter.

The KYMCO NEW Many 110 EV is the latest environmentally friendly scooter which is low-pollution, low-noise, and energy saving.

Although this Scooter has good quality, it still requires periodic maintenance to retain its best performance.

This Manual details how to properly operate the KYMCO NEW Many 110 EV Scooter, and the key points of its maintenance and adjustment for safe and comfortable riding for a long time.

In order to enjoy a safe and comfortable journey with your scooter, please read this manual thoroughly.

Model and type

EA10UA (meter type: noodoe version)

Core battery 10Ah Personal battery 13Ah Ionex System

EA10UB (meter type: LCD meter)

Core battery 10Ah Personal battery 13Ah Ionex System



Frame Number

Flip the seat open and read the frame number as shown in the figure.

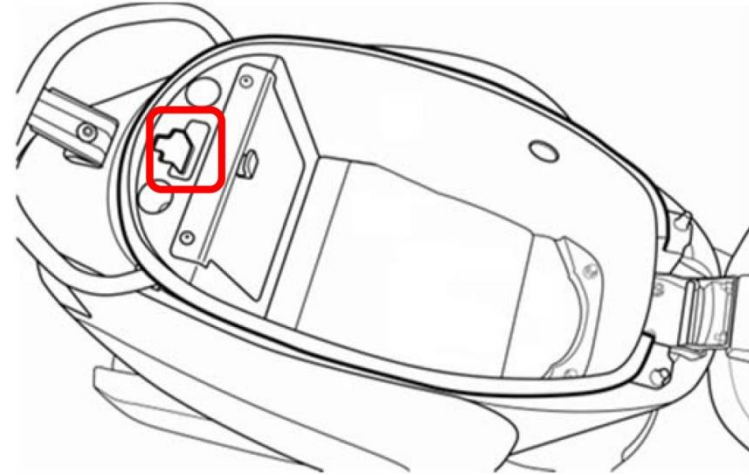

- Contents -

1. Safe riding	1	4. Meter.....	21
How to ride	2	5. How to enter the noodoe System.....	25
Clothing	2	6. Correct riding method	32
Load carrying.....	3	7. Correct Parking Method	37
Precautions.....	5	8. Scooter Charging	39
2. Parts Names.....	7	9. Battery characteristics	44
3. Operation of each part.....	10	10. Checks before riding and regular checks	46
Main Switch Cap and 2-in-1 Key	10	11. During a malfunction.....	53
Main switch cap	10	12. Change the fuse	54
Position of the Main Switch.....	11	13. Maintenance List	55
Steering Stem Lock.....	12	14. NEW Many 110 EV Scooter Specifications	56
Personal/Shared battery.....	13		
Cartridge Switch.....	14		
HI/LO Beam Switch.....	14		
Horn switch	15		
Blinker switch	15		
Front Hook	16		
Middle Hook	16		
USB Socket	17		
Side Stand.....	17		
Helmet Hook	18		
R Gear (reverse gear)	18		
Install the Personal battery	19		
Remove the Personal battery.....	20		

 Note: The actual product shall prevail if any contents in this manual differ from the actual product.

1. Safe riding

- As a responsible owner and rider.
- Possessing a valid scooter license issued by the R.O.C. government.
- Carefully read the Owner's Manual, including the warnings and precautions.
- You must understand how to properly operate your scooter, and ride it safely as well as correctly.



! Note

- You must use the charger from KY when charging the new battery for the first time. Fully charge the battery (until the green light on the charger is illuminated) to ensure normal battery operation.

- The rider must wear protective gear, such as a scooter helmet or gloves, motorcycle trousers, etc., in accordance with the laws and regulations.
- Do not wear the clothes which may endanger riding safety. For example, loose sleeves may be caught by the brake lever, causing danger.



Checks before riding

- Visually check tires for any foreign object or unusual abrasion.

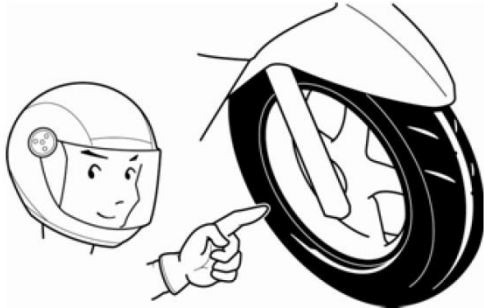

How to ride

- The scooter can only carry 2 people. It is dangerous for three people to ride the scooter and it is forbidden by law.



Clothing

- Buckle up long sleeves. Pull clothes in snugly to prevent sleeves from being caught by the brake lever.
- Wear a helmet and buckle up the chin belt.
- Hold the Handlebar with both hands when riding. Do not ride by single hand for this is extremely dangerous.
- Wearing flat shoes is safer.



- Vehicle functionalities are related to its structure. Arbitrary modification may deteriorate the operability of the vehicle, causing shortened service life and obstructing driver safety.
- Arbitrary modification of a vehicle is an illegal action forbidden by law. Never try to make any modification. Modification of the vehicle may result in a nullified warranty.
- Avoid making sharp turns or one-handed driving.
- Observe the Rules on Road Traffic Safety and pay attention to the traffic conditions at all times.

Load carrying

Operability of the handles varies depending on the extra load. The handle swings easily with an excessive load. Avoid riding with an excessive load.

The front hook has a holding capacity of no more than 3 kg.

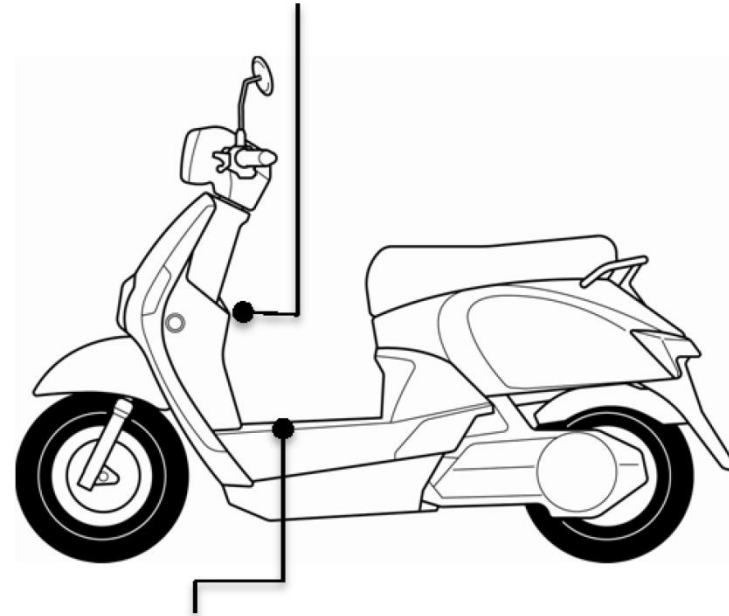

The pedal has a holding capacity of no more than 25 kg.

- Items must not stick out of the front hold and front carrying basket, otherwise the handle operation and front light will be obstructed and driving safety will be affected.
- The front carrying basket breaking due to excessive loading is not covered by warranty.
- An electric scooter has some parts that are different from those of a gas scooter. When using an electric scooter, you should be aware of this specific information, in addition to information for gas scooters.

- Regular checks are required.
- Regularly check every time before and after riding, as well as every 6 months, 12 months, 18 months and 24 months to ensure safe use of the scooter. Be sure to carry out specified regular checks.
- If you are unclear about something, go to the authorized shop or Kymco Service Center for consultation or inspection.

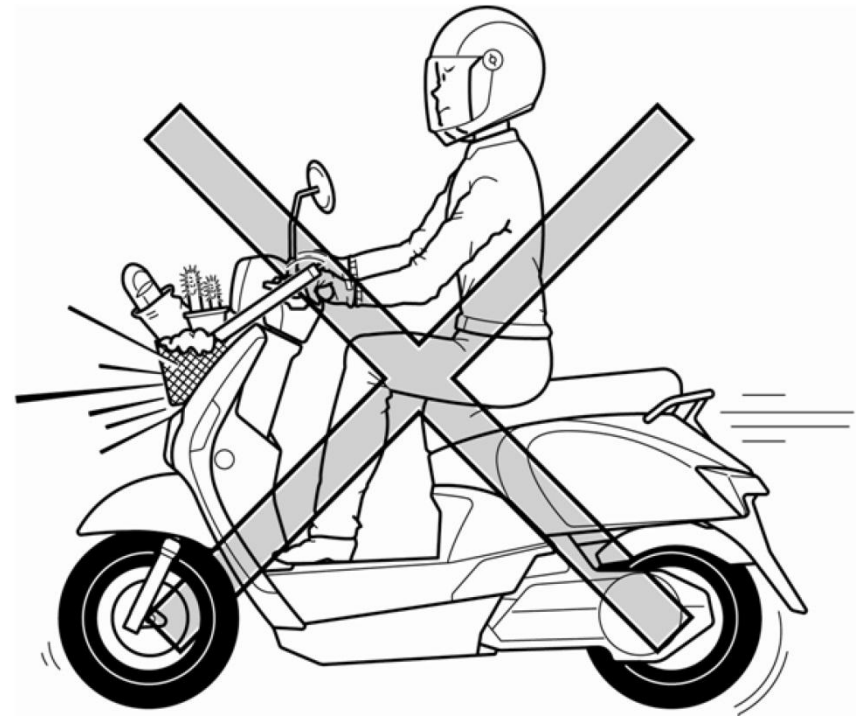

Precautions

- Kymco's electric scooter has some parts that are different from those of a gas scooter. Therefore, special and different precautions are listed. Please carefully read and follow these precautions.
- Terms in this manual (referring to Part Names)
- Electric shock
Under the normal use of this electric scooter, there is no risk of electric shock. If it is damaged due to an accident, or it is immersed into water or seawater due to flooding, its electrical system may be damaged. At this time, have it checked and repaired at an authorized shop or Kymco Service Center.
- Warning
Unlike a gas scooter, an electric scooter does not produce engine sounds when it is stopped. If you accidentally operate the Acceleration Handlebar, the motor will suddenly rotate, which causes sudden unintended acceleration of the scooter. This is very dangerous. Please take extra precautions. When there is no user on the seat, the main switch should be turned to the OFF position (refer to the main switch positions).
- Do not aim strong frontal water jets at the electric parts or battery sets when washing.
- During riding, the electric scooter makes less noise. If you want to pass a vehicle or pedestrian ahead, you must alert them using sounds to avoid danger.

- The horsepower of the motor slows down.
During riding, the motor power and speed may suddenly drop. This is not a malfunction, but a protective device. Riding on a hot day or on a steep slope adds a huge load to the motor, which will be constrained and slowed down when the temperature rises. The motor resumes normal operation after the motor returns to a normal temperature.
- Riding distance
This distance is estimated based on the assumption that a new battery runs out after it is completely charged. Frequent rushes forward, rush acceleration, low temperature, rainfall, going uphill and downhill, and harsh road conditions will shorten the riding distance.
- Trip distance (DIS)
The meter estimates the remaining mileage based on the battery capacity. This distance may vary depending on the user weight, operating habits, and number of batteries.
- Charging
After use, charge your scooter. If you do not charge it and leave it aside, its performance may easily decrease. If you will not use it for an extended period of time, charge it once every month (refer to Battery Charging).

- Wading precautions

It is forbidden to ride your scooter across roads with water which is higher than half of your wheels.

If water enters the bottom (terminals) of the Smart energy bay, go to the authorized shop or Kymco Service Center for inspection and repair immediately.

- If the user has a pacemaker implanted, it is inappropriate for him/her to ride an electric scooter.
- Turn the main switch off when not riding the scooter.
- This product is suitable for use under an altitude of less than 2000 m.
- If there is dirt on the connector, you need to perform adequate cleaning on it to maintain proper functions.
-  The battery is energized and be cautious of electric shock.
- When the scooter is stopped and you do not use it, charge the Core/Personal/Shared battery fully.
- The Personal battery is the property of Kymco and the user only has the right to use it. Attention should be paid during use and avoid damage to the appearance.
- Do not brace up the main stand for idle rotation. This may cause the battery run out and the increase of total mileage.

2. Parts Names

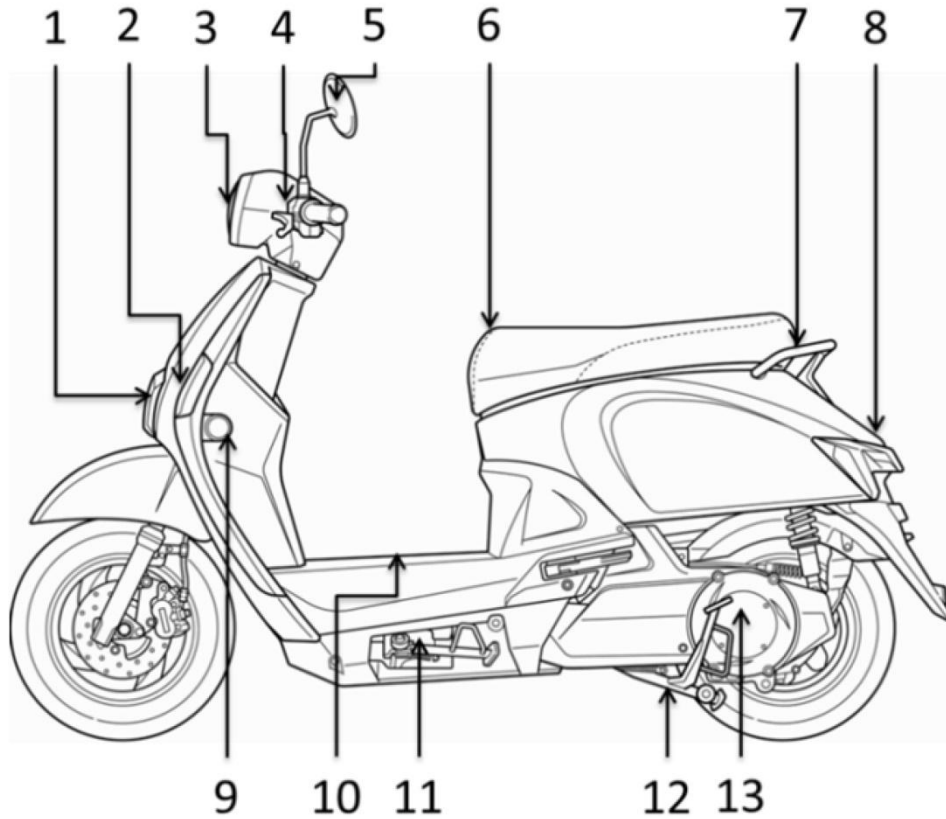

1. Daylight
2. Front Blinker
3. Headlight
4. Brake Lever
5. Side Mirror
6. Seat (luggage box)
7. Rear Armrest
8. Tail light/Rear Blinker
9. Reflective Sheet
10. NFC Sensor
11. Side Stand
12. Main Stand
13. Motor

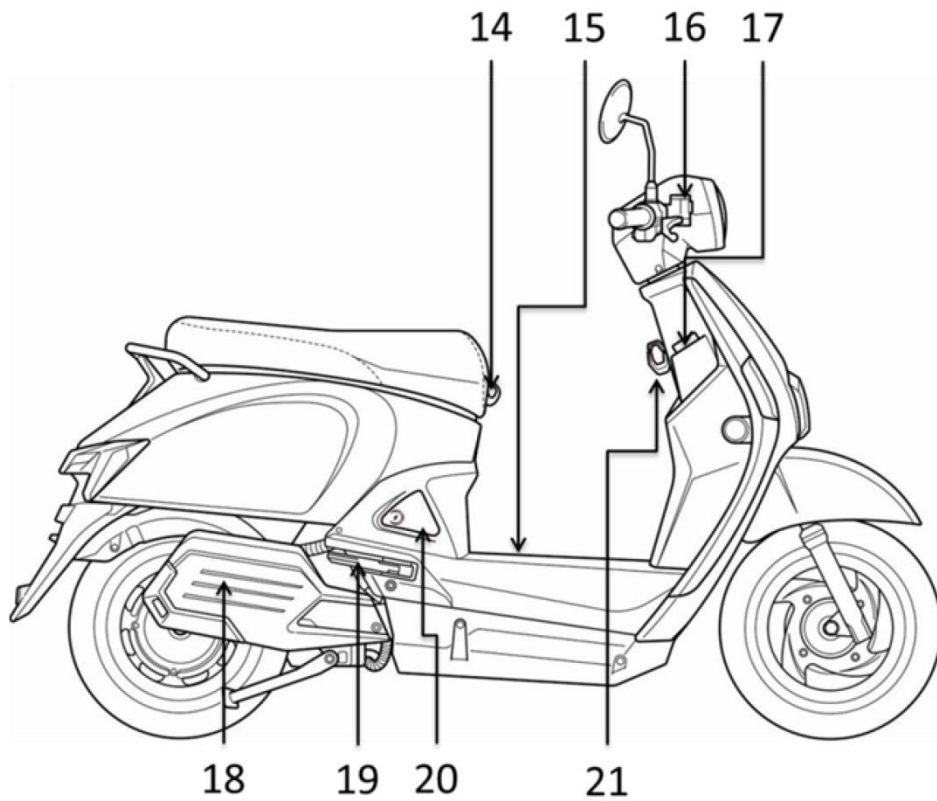

- 14. Middle Hook
- 15. Smart energy bay
- 16. Disc Brake (EA10UB uses drum brakes)
- 17. Main Switch
- 18. Motor Controller
- 19. Rear passenger foot peg
- 20. Charging Outlet
- 21. Front Hook

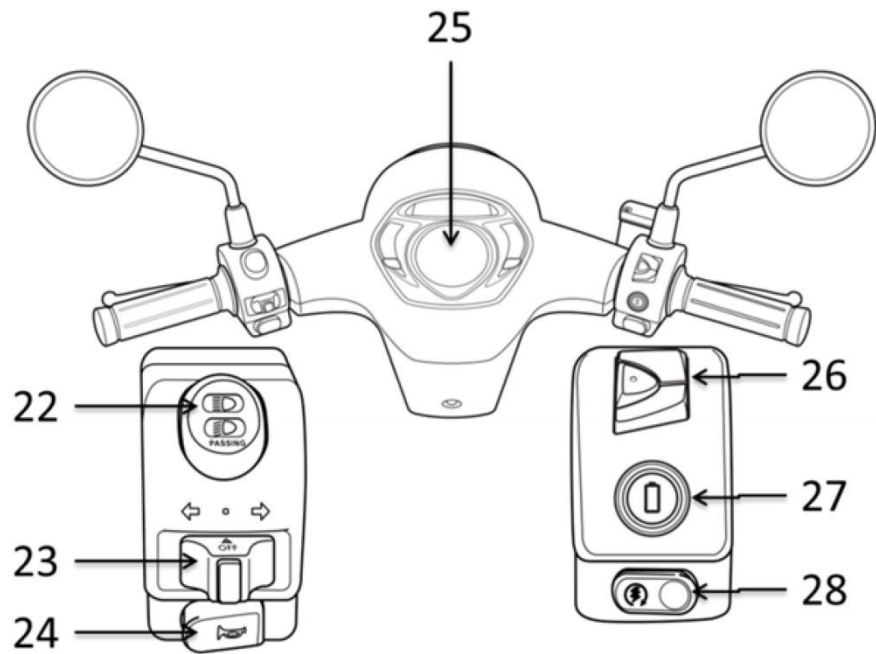

- 22. Headlight Switch
- 23. Blinker switch
- 24. Horn switch
- 25. Meter (EA10UB: LCD meter)
- 26. noodoe button (EA10UB does not have this button)
- 27. Cartridge Switch
- 28. POWER Mode/Start-up Switch

3. Operation of each part

➤ Main Switch Cap and 2-in-1 Key

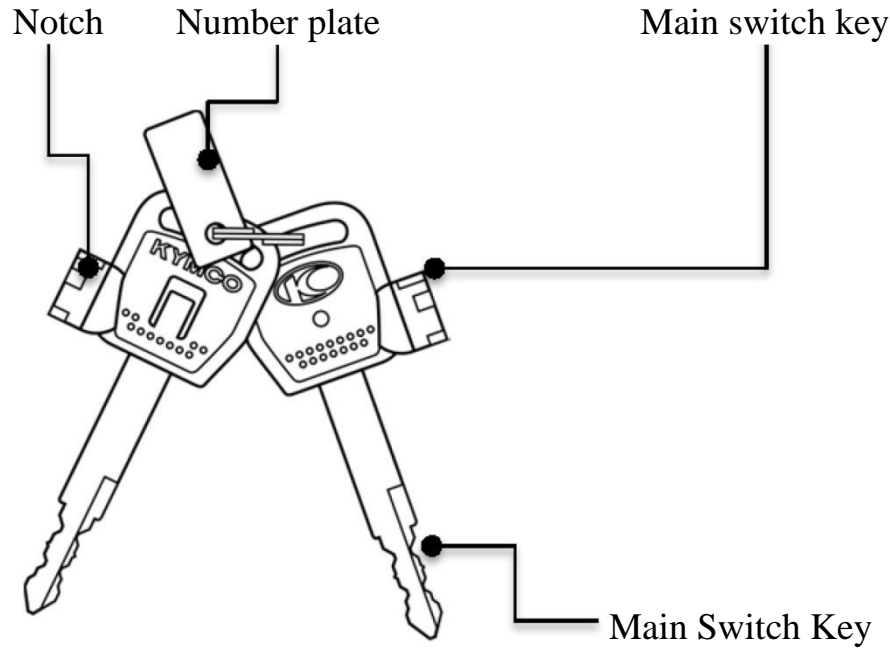

➤ Main switch cap

For anti-theft protection, lock the main switch cap when parking.

Locking Method:

Push the main switch key upwards to close the main switch cap and phone charging station.

Unlocking Method:

Fit the notch of the main switch cap key to the tongue of the main switch cap key hole and turn right to open the main switch cap.

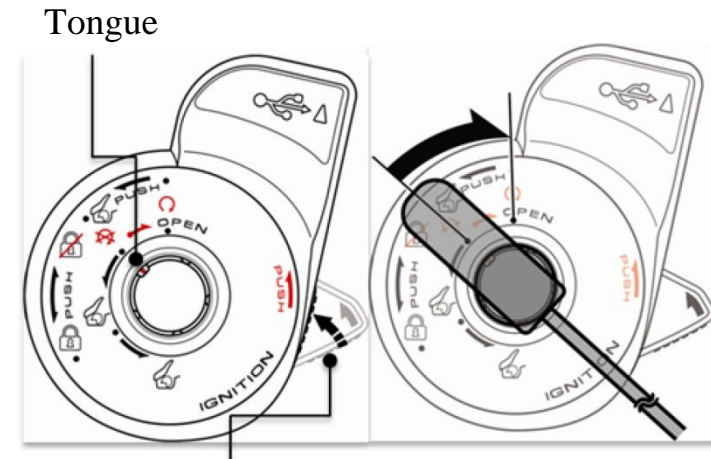



Note

If your main switch key (magnetic key) is lost, please buy a new one from the dealer you bought your scooter from according to the key number plate.

➤ Position of the Main Switch

: The Steering Stem is locked in this position. The key can be pulled out.

: All vehicle power is cut off in this position. The key can be pulled out. (Engine off)

: In this location, the scooter is totally powered on and the headlight and position lights are lit up. You cannot pull the key off at this time. (The system can be activated)

SEAT OPEN: The device is used to open the rear luggage box.

The device can be used to open the luggage box in three different situations.

- (1) Open the luggage box when the engine is off.
- (2) Open when in the KEY ON/START state.
- (3) Open the luggage box when the steering stem is locked.

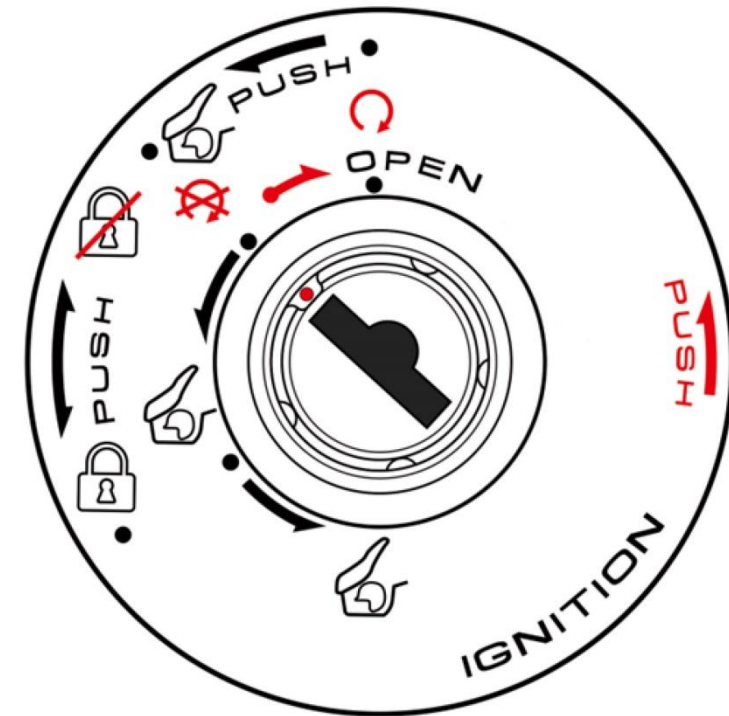

Note

- When riding your scooter, do not turn off the main switch or turn it to the LOCK position. This is the main reason for accidents.
- If you turn the motor power system on and off while it is operating, this may decrease the motor controller. If you turn off the power during riding, the system will enter the protection state if you turn the KEY ON again. Make sure that the scooter is started (brake and press the Start-up Switch) only when it is stopped (the speed is zero) to ensure the safety of the user.

➤ Steering Stem Lock

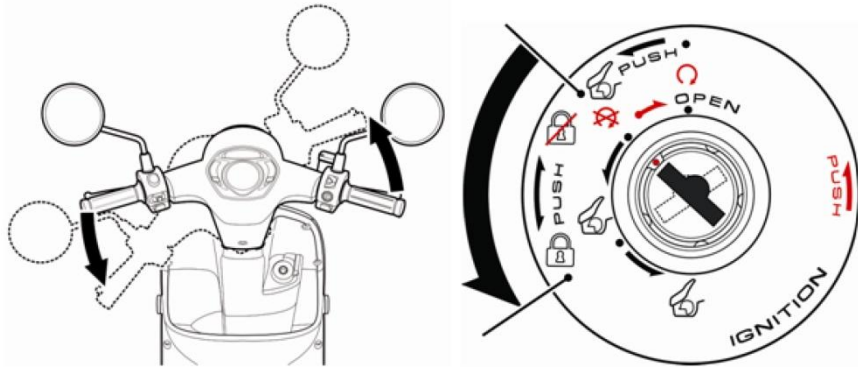

For theft prevention, lock the steering stem when parking your scooter.

Locking Method:

Turn the steering stem left to the end, insert the key and pressure, turn it left to LOCK, and pull out the key.

Unlocking Method:

Insert the key and turn it right from LOCK to OFF to unlock the steering stem.

⚠ Note

- When in LOCK, turn the steering stem lightly to check if it is locked.
- Do not park your scooter at locations where traffic safety may be obstructed

➤ POWER Mode/Start-up Switch

When this button is pressed, the meter LCD will display POWER and your scooter will enter POWER mode. In this mode, a larger current is output during continuous hill climbing so that it will be more powerful for hill climbing. Press this button again to return to normal mode.

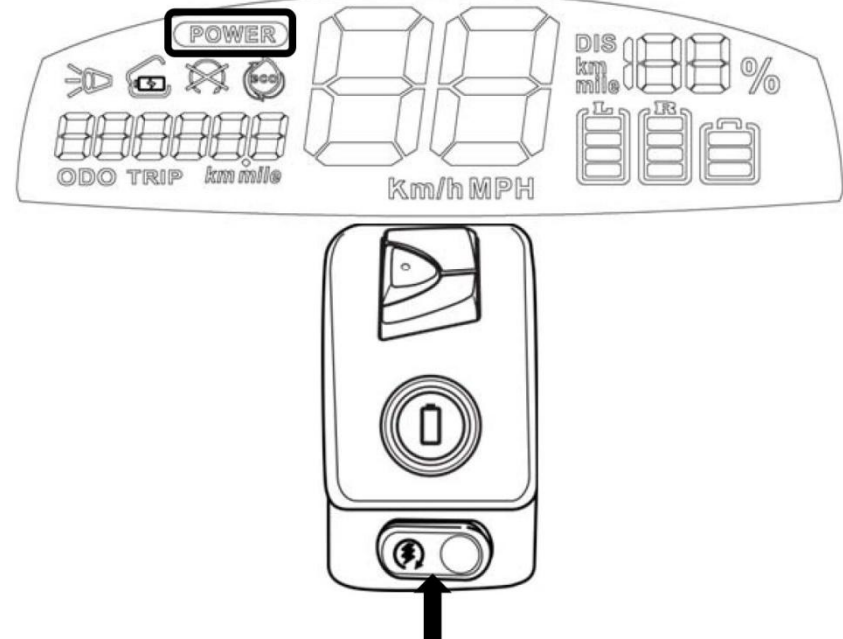

⚠ Note

When POWER is activated, the meter LCD will display POWER. Press the Switch again and the text POWER on the LCD disappears to return to normal mode.

➤ **Personal/Shared battery**

QR Code (above the battery)

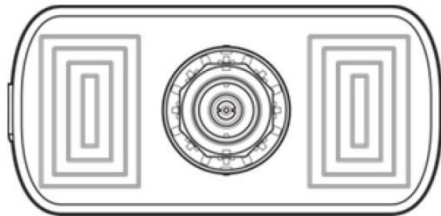
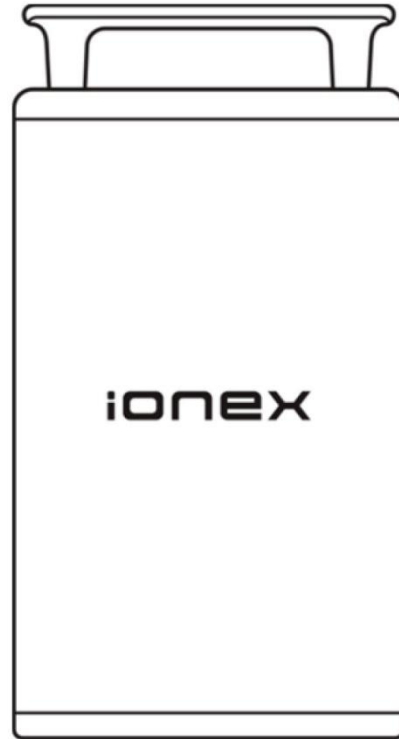
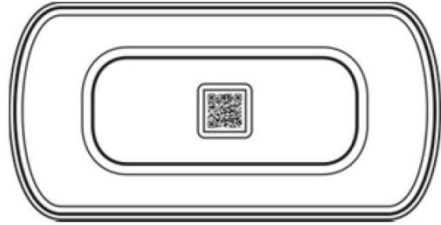

Smart Sensors (on both sides of the battery base)

! Note

When you use the Personal/Shared battery to sense the pedal, point a Battery Base Smart Sensor (on either side) at the pedal  icon to open the Smart energy bay.



Personal battery
(white handle)

Shared battery
(orange handle)

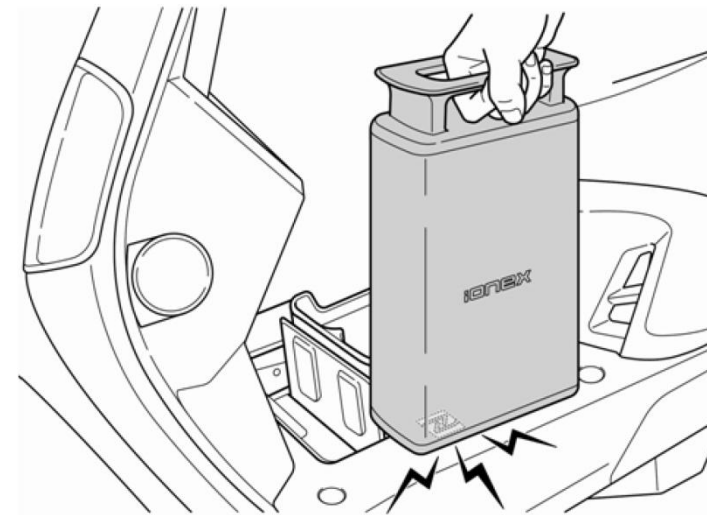

➤ Cartridge Switch

Brace up the main stand and turn on the main switch. Press the cartridge switch on the right handlebar and the Smart energy bay of the pedal will close or open.

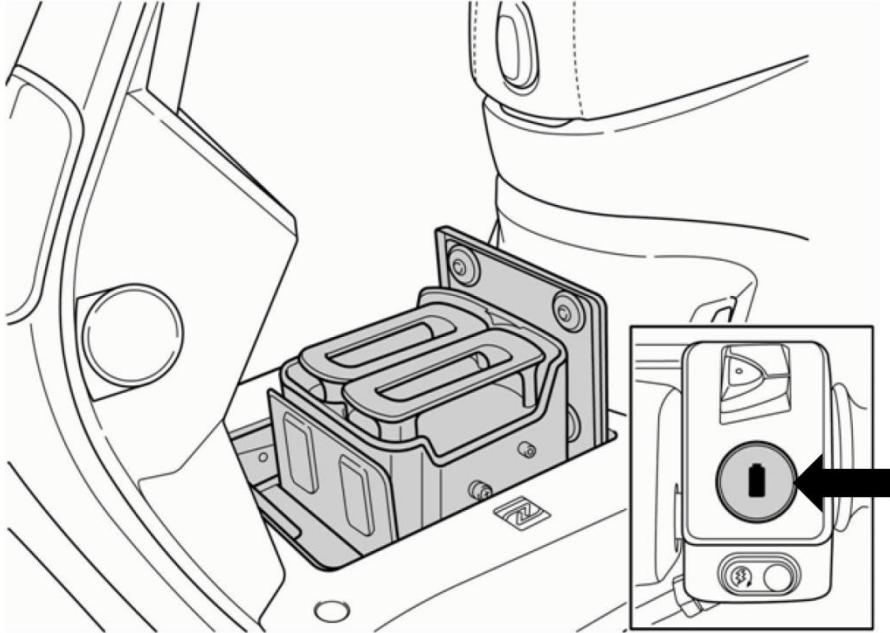

! Note

- If the Smart energy bay does not operate smoothly (jitter) when opened, go to the authorized shop or Kymco Service Center for inspection and repair immediately.
- You must brace the main stand up on level and flat ground to open the Smart energy bay for replacement of the Ionex (Personal / Shared) Battery.

➤ HI/LO Beam Switch

It is used to switch over between high beam and low beam.

 : Turn to this position for high beam.

 : Use low beam when you are riding in urban areas or when there are vehicles coming in the opposite direction to avoid affecting the view of other drivers.

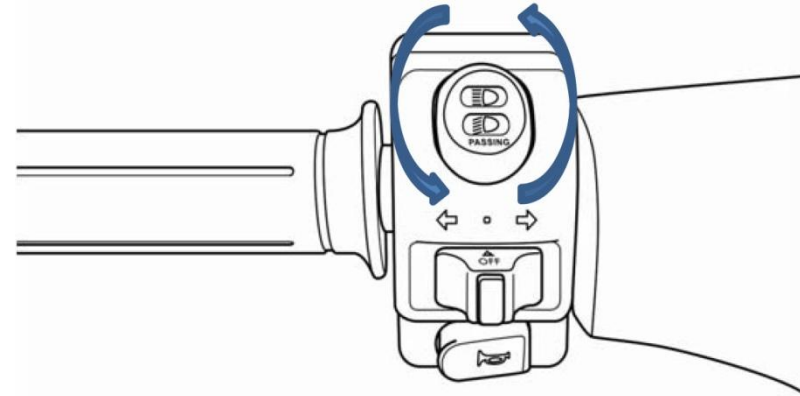

! Note

- After riding, do not cover the headlight using any item (such as your coat, jacket, raincoat, or scooter cover, etc.) to avoid poor heat dissipation which may cause damage to the lamp covers and danger.

➤ **Horn switch**

The horn will sound when the main switch is turned ON and the Horn switch is pressed.

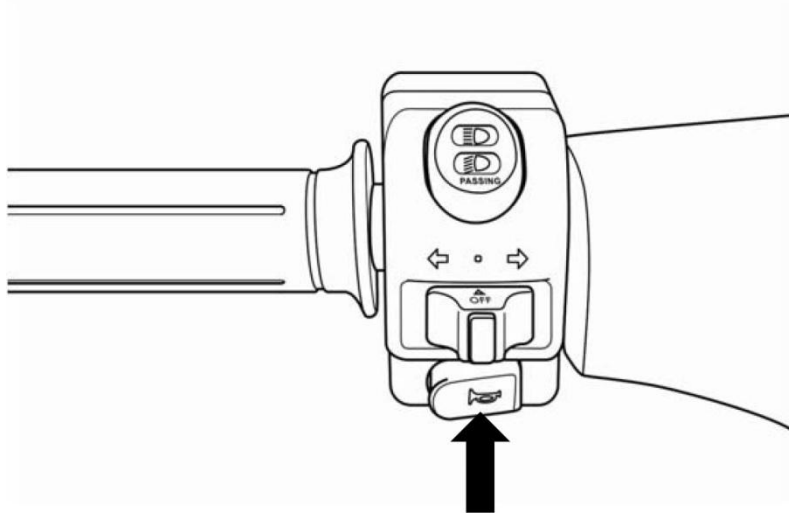

➤ **Blinker switch**

When you make a turn or change lanes, you should use the Blinker. The Blinker goes off when pushing the switch back.

←: Use this position for Left Turn.

→: Use this position for Right Turn.

(The main switch is turned ON.)

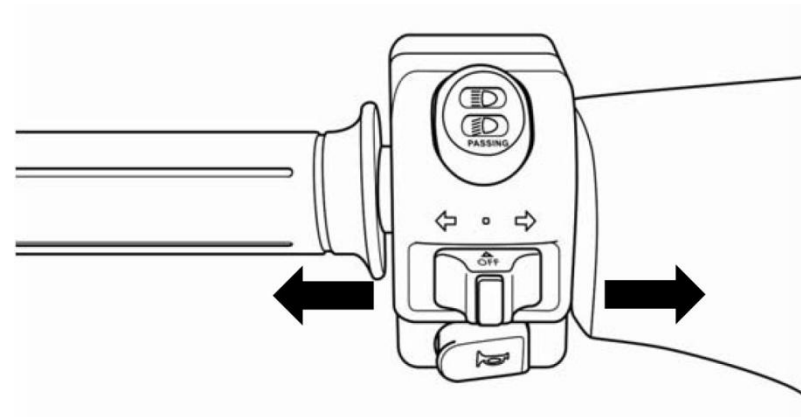

! Note

The Blinker will not automatically go off, and you should return it to normal. If you forget this, the driving safety may be affected.

- The blinker will not be activated when the main switch is at “~~OFF~~”.

➤ **Front Hook**

Light objects can be hung on the front hook. However, the object must not be heavier than 3 kg, otherwise the hook might break.

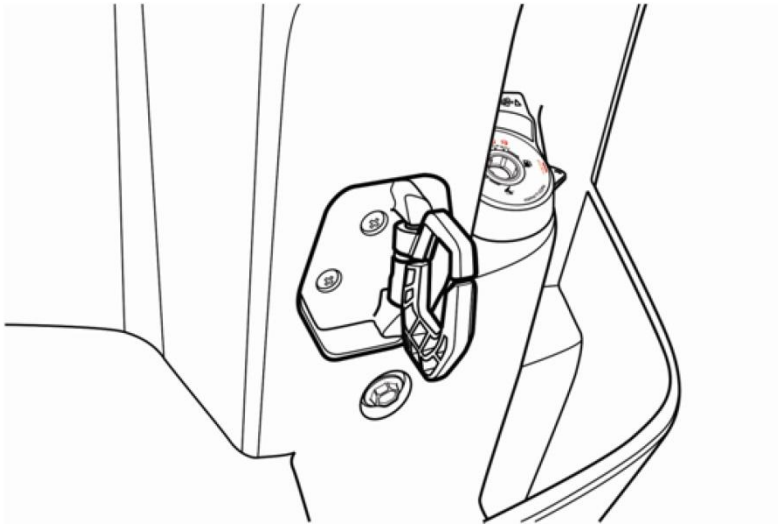

➤ **Middle Hook**

This Hook can carry lighter items which should not be heavier than 3 kg. Otherwise, it may be broken.

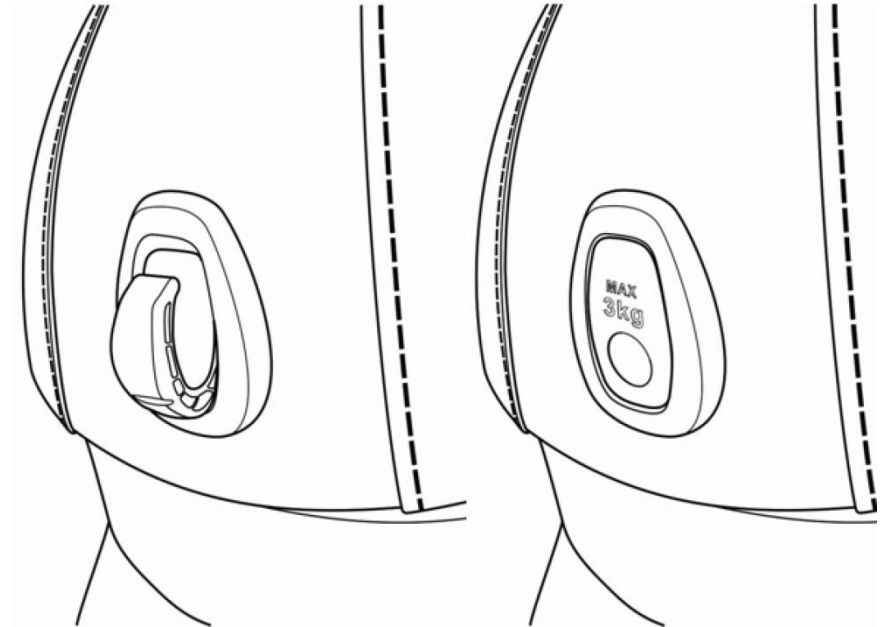

➤ **USB Socket**

Charging digital products of 1A and below is suggested.

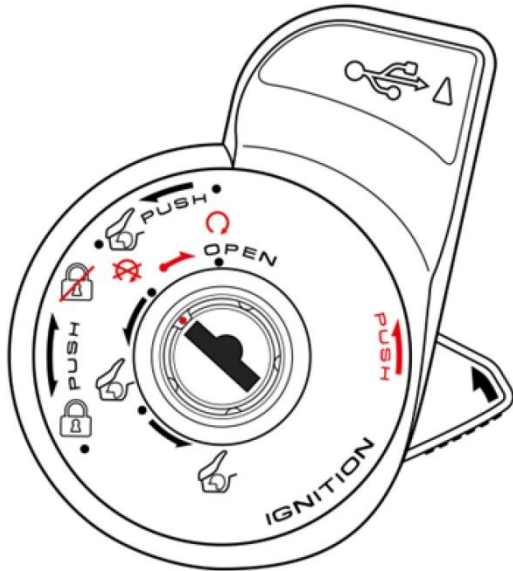

USB Socket

Item	Specifications
Output voltage	DC 5V
Output current	It is suggested to use the digital device with 1A and below for charging.

➤ **Side Stand**

The Side Stand not only is used for parking, but also contains one safety mechanism.

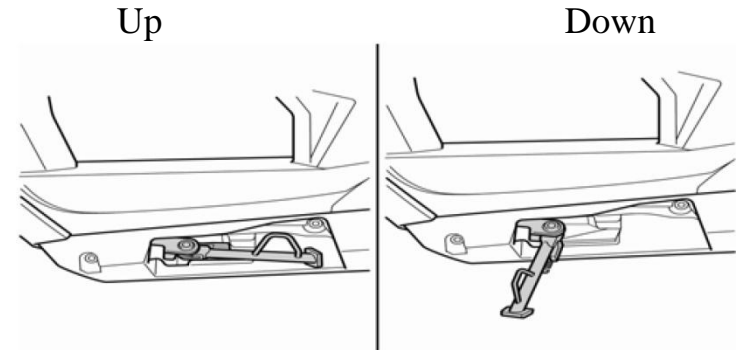

When the Side Stand is down, the meter displays the auto power disconnection icon and the Service Lamp lights up.

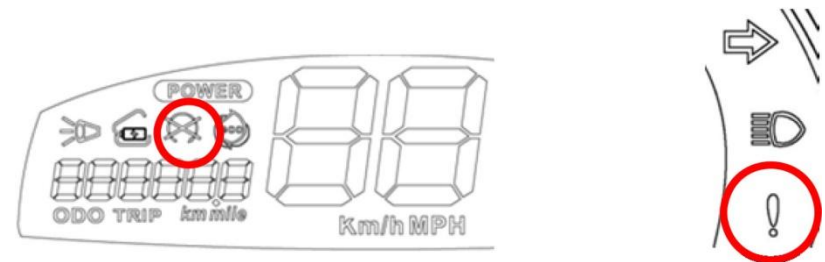

! Note

- During parking, always turn off the main switch if a child or elderly person sits on your scooter.
- If you have to park your scooter for a long time, we recommend that you use the Main Stand.
- If there is any problem with the Side Stand, go to your local authorized Kymco shop to have it checked.

➤ **Helmet Hook**

Instructions for Use:

1. Open the seat and flip it up.
2. Lock the helmet retaining ring into the helmet buckle.
3. Put down the seat and push down the rear end of the seat to lock it.

Instructions for Removal:

Open the Seat and remove your helmet according to the instructions.

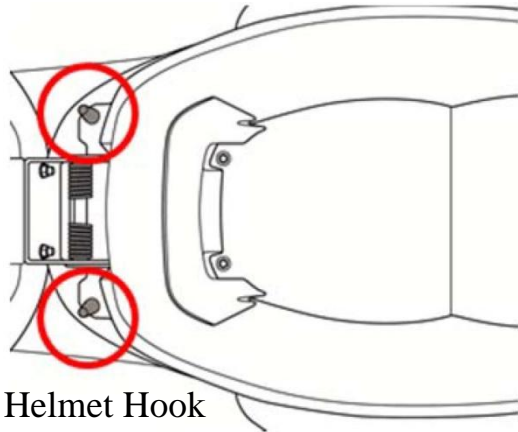

⚠ Warning

- Do not lock the helmet in place while riding to avoid damage to parts or the coating.
- Never lock the seat while leaving the key in the luggage box.

➤ **R Gear (reverse gear)**

Press the R Gear (continuously pressed) before the left handlebar switch, and the meter indicator (as shown below) lights up. The reversing warning sounds are made and the scooter enters Reverse mode. Use the Acceleration Handlebar to reverse it.

Release R Gear and deactivate Reverse mode.

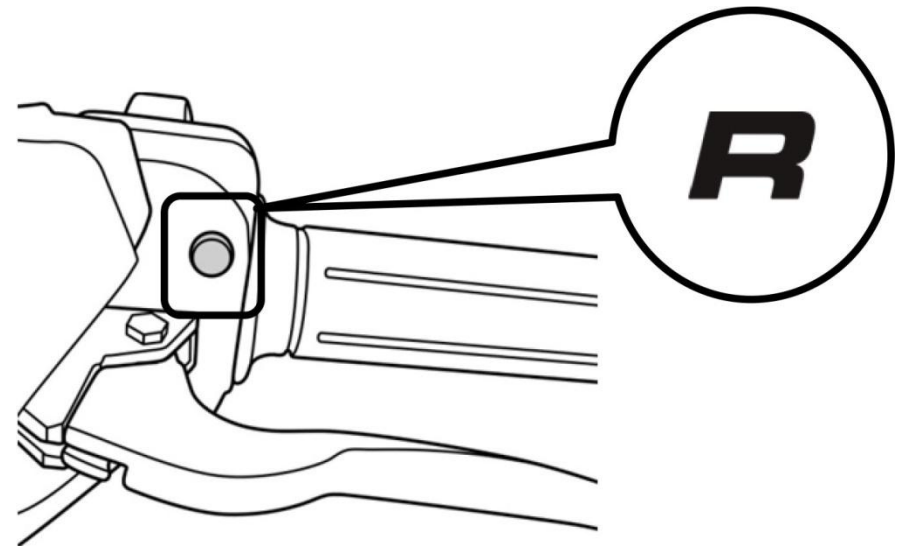

⚠ Warning

- When operating R Gear, always watch out for your back and your safety.
- In the START state, the speed should be zero to enter Reverse mode.

➤ Install the Personal battery



1. You must brace the main stand up on level and flat ground.



2. The NFC sensing label is located on the left side of the pedal.

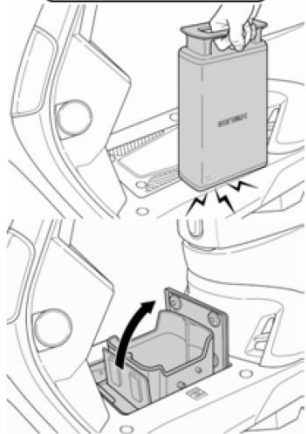

3. Sense the NFC by holding the Battery bottom (either side) close to it.

4. The Smart energy bay opens.

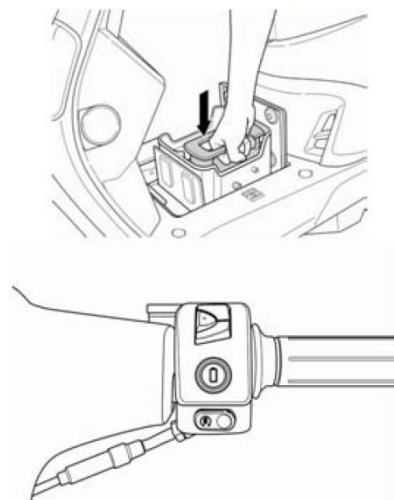

5. Mount the Personal battery until it is in place.

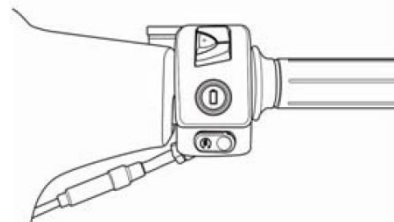

6. Press the cartridge switch on the right handlebar to close the Smart energy bay.



Installation position

! Warning

When the second Personal battery has to be installed in the scooter, refer to Fig. 6 and the installation position (the shaded area in the figure above) for the correct removal position.

➤ Remove the Personal battery



1. You must brace the main stand up on level and flat ground.

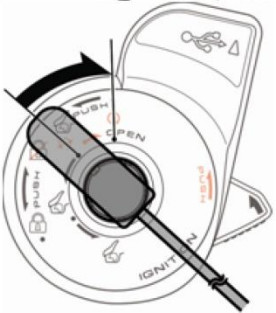

2. Turn the main switch key right to ON.

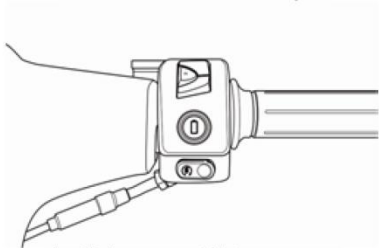

3. Press the cartridge switch on the right handlebar to open the Smart energy bay.

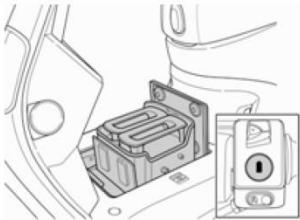

4. The Smart energy bay opens.

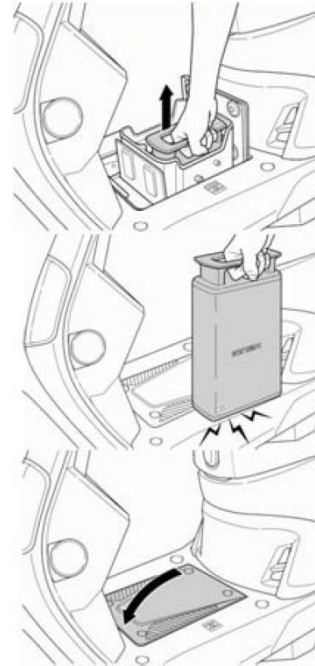



5. Lift the Personal battery upwards.

6. Sense the NFC by holding the Battery bottom (either side) close to it.

7. Close the Smart energy bay.

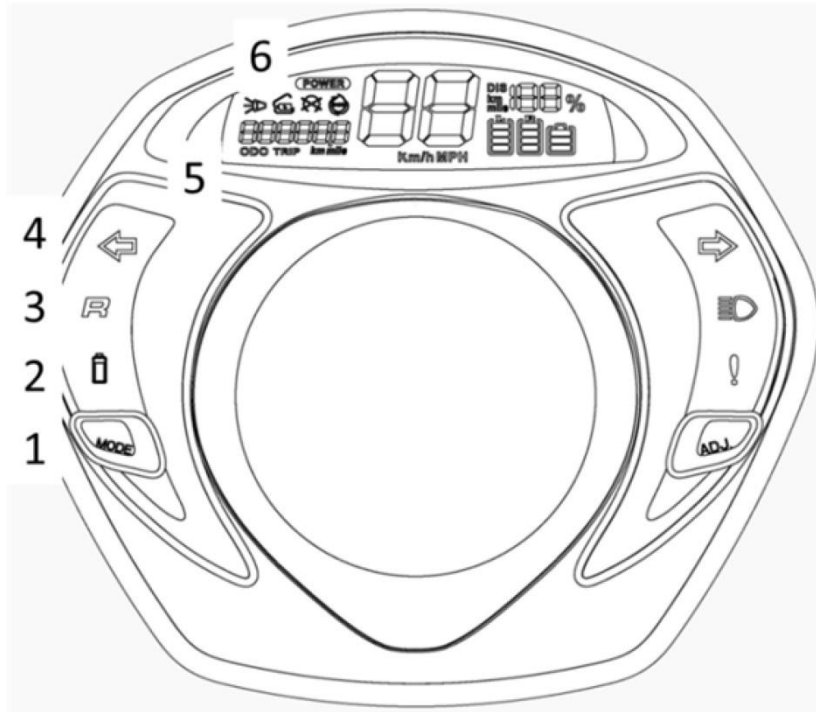
4. Meter



1. **MODE** button (setup button):
Short press it to switch between the ODO/TRIP state.
Long press it to switch between km/mile.
2.  Core battery/Charging State Indicator: The KEY ON/START state indicators lights up in yellow to indicate the scooter power is switched to Core battery. During charging, the indicator flashes in yellow. After charging, it flashes in green. If the indicator lights up in red, charge it.

3. **R** Reverse Indicator: press the R Gear (continuously pressed) before the left handlebar switch, and the meter indicator lights up. The reversing warning sounds are made and the scooter enters Reverse mode. Use the Acceleration Handlebar to reverse it.

4.  **Blinker**:
The indicator is illuminated when the Blinker switch is activated.

5. **ODO** Accumulated distance: This indicates the accumulated distance in total (km).
TRIP is for calculation of a single-trip distance.
Press the **MODE** button and it cycles through ODO→TRIP.

6. **POWER** **POWER** indication:
When **START/POWER** is pressed, the meter LCD displays **POWER**. Press it again and **POWER** disappears.

 : Low-speed warning sound (speed < 20km/hr).

 : The battery cover is not closed properly.

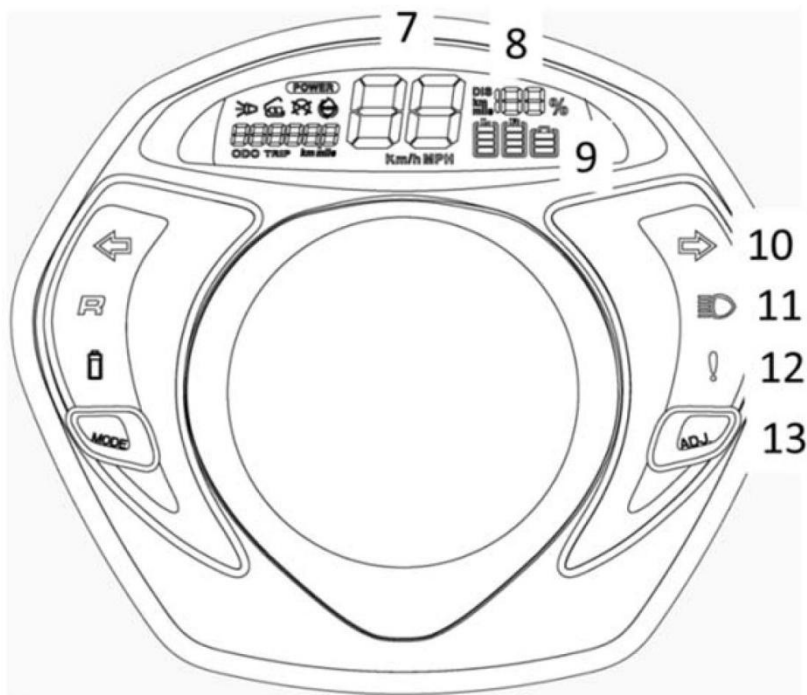

: The capacity disconnection indication:
When the Side Stand is down, the meter LCD displays the power disconnection icon and the Service Lamp lights up in yellow. It is impossible to start the scooter.

 **Note**

When the scooter is not started, the meter LCD displays the power disconnection icon

: Energy saving indication: During riding, the meter indication appears. At this time, energy is saved.

- 7. Speedometer: It displays the speed in km/hr or ml/hr.
- 8. DIS Estimated Remaining Mileage: The battery capacity and constant speed are used to calculate the remaining mileage.

9. : Display the battery capacity

: Personal battery/Shared battery

: Core battery

10.  Blinker

11.  HI Beam Indicator:

When it lights up, the headlight is in the HI Beam position.

12.  Service Indicator:

When the Side Stand is down, the indicator lights up. After the main switch is ON, if the indicator lights up steadily or flashes continuously, you have to bring your scooter to the Kymco authorized shop for inspection.

13. ADJ button (adjustment button):

Function setting: Press ADJ for about 2 seconds to switch between DIS and SOC%.

Zeroing setting: In TRIP Mode, long press ADJ for 2 seconds.

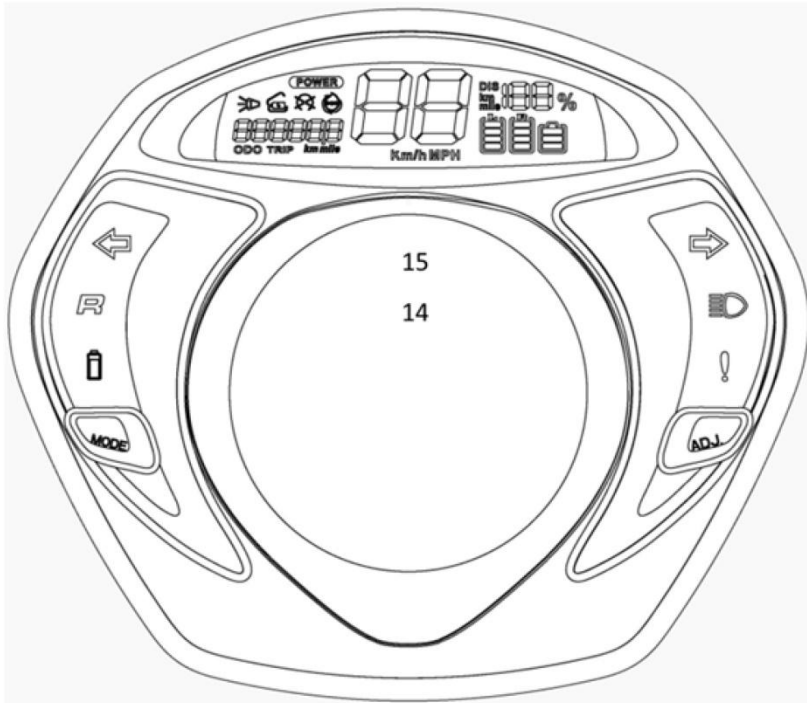

In ODO Mode, long press the MODE button for 2 seconds to switch between km and ml.

In ODO Mode, long press the ADJ button for 2 seconds to turn on/off low-speed horn.

! Note

- EA10UA (meter type: noodoe version)
- EA10UB (meter type: LCD meter)

14. : noodoe connection symbol: When your scooter is connected to your phone, the symbol appears.

15. Time settings (EA10UB)

- A. In ODO Mode, press “MODE” + “ADJ” for 2 seconds to enter Settings mode. At this time, “H:M” flashes.
- B. When “H:M” flashes, press the “Adj” button to increase the number progressively (00~23). After “H:M” is set, press the “Mode” button to enter the Settings mode of “H:M.”
- C. When “H:M” flashes, press the “Adj” button to increase the number progressively (00~59). After you perform adjustments, press both buttons to finish the time setting (“H:M” does not flash).
- D. When adjusting the number, press the “Adj.” button once to increase by 1. If the “Adj.” button is pressed and held for 2 seconds, the number will be increased progressively. The setting values will cycle through. (It takes 2 seconds to cycle through 0 to 9).
- E. When “H” is 00~09, “0” in the tens place is hidden.

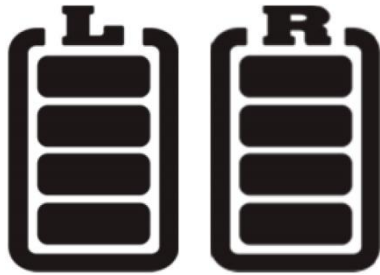

1. The Personal battery/Shared battery has a capacity of 13 Ah. Refer to the table below for the rough remaining capacity (the remaining capacity of the healthy battery):

The capacity is 76~100% if four bars are illuminated.

The capacity is 51~75% if three bars are illuminated.

The capacity is 25~50% if two bars are illuminated.

The capacity is 10~24% if one bar is illuminated.

The capacity is 10% or less if one bar is flashing.

! Note

When only one bar is flashing for the Personal battery/Shared battery, use an adequate measure to charge the battery.

2. The Core battery has a capacity of 10 Ah. Refer to the table below for the rough remaining capacity (the remaining capacity of the healthy battery):

The capacity is 67~100% if three bars are illuminated.
--

The capacity is 34~66% if two bars are illuminated.

The capacity is 10~33% if one bar is illuminated.

The capacity is 10% or less if one bar is flashing.

3. The capacity is displayed as “Relative Capacity”. When the battery deteriorates, the capacity for one bar will decrease proportionally based on the deterioration level. Therefore, users can estimate the normal battery capacity precisely.

! Note

The battery with low capacity will discharge first, while the one with high capacity will charge first.

5. How to enter the noodoe System

(EA10UB uses a LCD meter)

Step 1: Download the app. Refer to “Download noodoe app,” download the app and the system installs the app automatically.

Step 2: Refer to “Introduction of Operation Buttons” for an introduction to the operation buttons.

Step 3: Refer to “Scooter Pairing” and creation upload for scooter pairing.

noodoe Function

A. Refer to “Introduction of App Function/Create Mode” for an introduction of app functions.

B. Refer to “Find My Scooter” for locating scooters.

C. Navigation function.

D. Refer to “Message Notice” for the message notice function.

E. Refer to “Welcome Light” for the welcome light function.

Step 1: Download the app.

Go to Google Play (Android) or App Store (iOS) directly, and type the keyword “noodoe” to search for it.



Note

- ◆ Minimum supported version: Android 4.4.4 or above, iOS 10 or above.
- ◆ You cannot run the app if your phone doesn't support Google service.

Step 2 Introduction to operation buttons

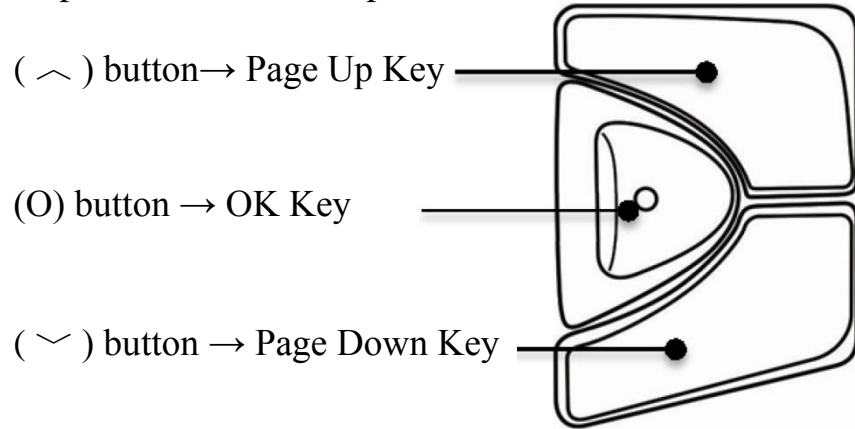

Note

If the user updates it to APP version 1.5, pay attention to the following differences

- When turning on the main switch, within 30 seconds long press the (O) button for 5 seconds to enter “Pairing Mode.”
- When turning on the main switch, within 30 seconds long press the (O) button for 5 seconds to enter “Version Review Mode”.

When riding

- Operate the (^) and (v) buttons to switch between 4 screens of Dashboard noodoe functions.
- Press the (O) button to end the action.

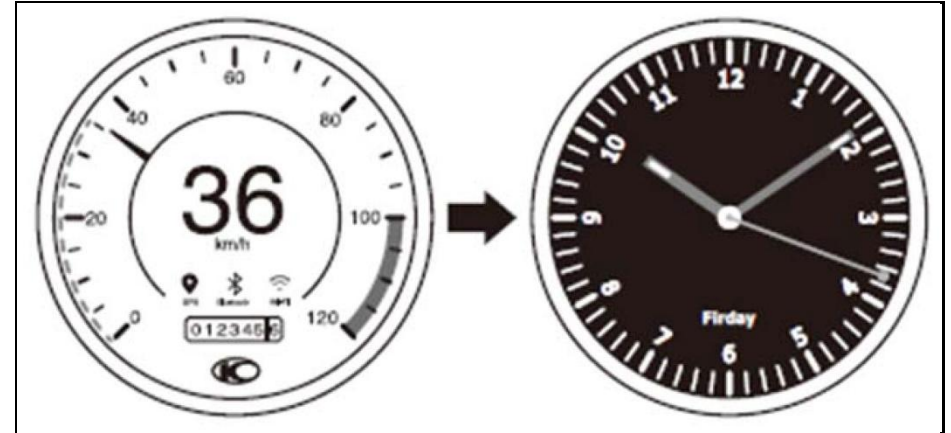

When Stopped:

Message Notice:

- Operate the (^) and (v) buttons to switch between message notices in the Dashboard noodoe Function.
- Press the (O) button to activate or close message notices.

Step 3: Scooter Pairing

When the user pairs with his/her scooter, he/she must sign up for a new account. KEY ON (scooter) → long press the (O) button within 30 seconds to select a new user (scooter) → display the device name (scooter) → turn on the Bluetooth device (phone) → select the Bluetooth device (phone) → verify the pairing code (phone and scooter) → press the (O) button to select → pair them successfully.



A User created Dashboard can be installed onto the scooter.

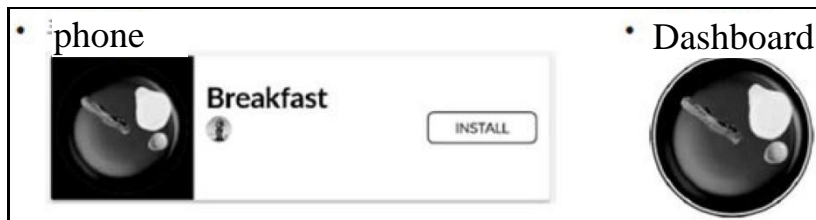

noodoe Function

A. Introduction to app functions

- The user may browse and collect creations from users all over the world and install them into the Dashboard of your scooter.
- The user may collect or remix any creation they find, or design their own Dashboard in Create Mode.



1. Home

2. Dashboard

3. Activity

Create Mode

- Create Mode allows you to remix an existing template to your liking.
- Pick between Clock, Weather, Compass or Speed and unleash your creativity. You can change colors, fonts, upload your own images and more.

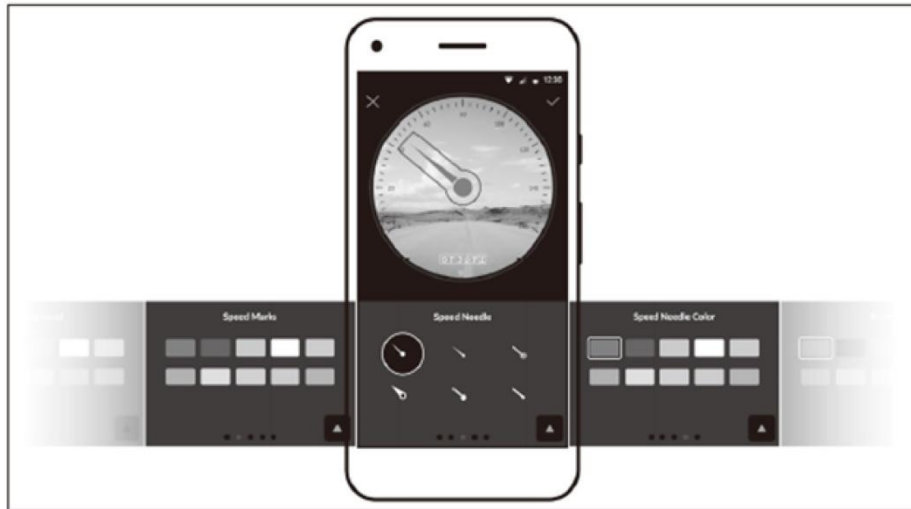

B. Find My Scooter

- Forgot where you've parked? No worries, noodee remembers.
- Tap the  icon and the app will guide you back to where you last parked.
- Find your scooter either on the map or by following the directions from the app, complete with distance and direction.



Both Bluetooth and Internet functions should be activated in your cell phone.

There are 2 modes of “Find my Scooter” display

1. Map Mode
2. Azimuth Mode

C. Navigation function



You need to update your noodoe APP to synchronize with your scooter and have the powerful noodoe Navigation function. You can setup locations on your phone and after synchronization with your scooter, activate the noodoe Navigation function.

Note

- ◆ When you use the Navigation function for the first time, you need to download the local map.
- ◆ The current progress and future planning of the navigation route are displayed only when the scooter is completely stopped and the rider can safely read them.

D. Message Notice

Once the cell phone is linked, any incoming message will be forwarded to the scooter dashboard (Android users may select their display with → Settings → Application).

While Driving:



A message “For the sake of safety, no message is viewable when you drive the scooter.” is displayed on the top of the noodoe Dashboard.

When Stopped:

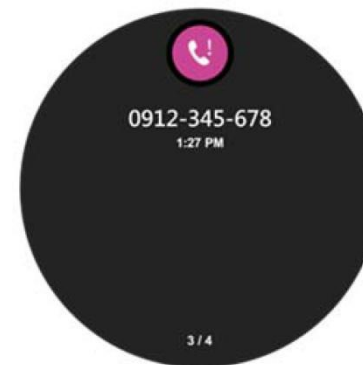

Any message received during your ride will be displayed automatically when you make a subsequent stop.

You may also press the UP/DOWN button on the right handlebar switch (only when you stop the scooter) to manually search message contents.

E. Welcome Light

Every time you approach your vehicle, it will greet you with a Welcome Light. This is very useful when you're looking for your vehicle in a crowded parking area or at nighttime.

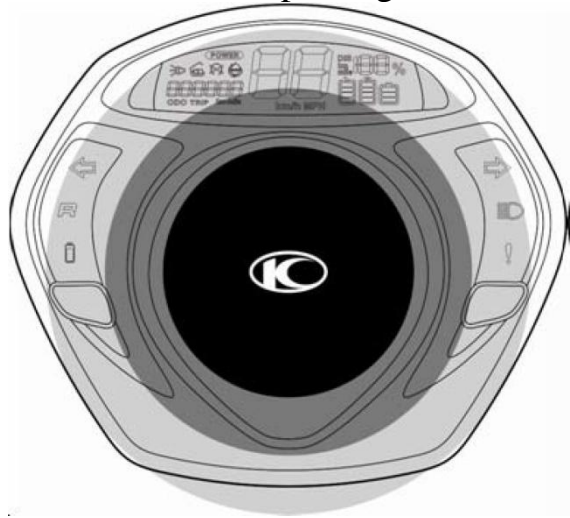

! CAUTION

- ◆ When using the noodoe function, make sure that the batteries of both the cell phone and scooter are fully charged.
- ◆ When turning off the power and the battery power is low, the noodoe system turns off Bluetooth/ Connection/ Welcome Light automatically. Go to a KYMCO authorized store for repair if you cannot use these functions after starting the vehicle.

! Note

1. For enhancing the accuracy of displayed weather and local information, you should activate the GPS and Network functions of your cell phone. (In case of cell phone signal failure, previous information will be displayed until resumption of the cell phone signal which enables the display of accurate information).
2. Switching over of Speed / Temperature / Time units is carried out from the cell phone; minor differences resulting from the frequency of data updating is within a reasonable range.
3. Scanning speed and results of Bluetooth Device may be limited in compatibility issues due to cell phone specifications.
 - a. Scanning speed of Bluetooth Device is slow.
 - b. Pairing is unsuccessful.
 - c. Bluetooth error occurs during the link.
4. The User needs to set the cell phone's Cloud Messaging function to facilitate noodoe message display.
5. While driving, noodoe will not display any message (including incoming call, message, LINE, FB, etc.). When the vehicle stops, noodoe automatically displays incoming calls and relevant information.
6. The last screen at the previous shut down will be the first screen on a restart.

7. The compass function must be activated by performing setup on a cell phone. Minor errors may exist depending on data update frequency.
8. The compass only performs self-verification to modify orientation when the vehicle starts to move, therefore it is normal that no orientation calibration is activated after connecting the noodoe App while the vehicle has not yet started moving.
9. Time in noodoe will be calibrated automatically after connecting noodoe with a cell phone.
10. The user shall never operate noodoe while riding the vehicle or an accident may occur.
11. The action of the Welcome Light function can be set using an app (enabled or disabled).
12. When Welcome Light is set to enabled:
 - A. The Welcome Light is only activated on a subsequent connection of a Bluetooth Device. Each activation lasts for 2 minutes before switching off automatically.
 - B. After each ride, a single cell phone linkage will only activate the Welcome Light 3 times; the Welcome Light will shut off Bluetooth functions automatically after being activated 3 times.
 - C. Entering the Find My Scooter screen will cover functions a and b, in which case the system enables the Welcome Light until the user gets out of Bluetooth range or disables the Bluetooth connection function.
 - D. The device standby time is 1 day. 1 day later or when the system automatically detects that the battery voltage is too low, the Welcome Light or Bluetooth function will be turned off.
13. When the KEYLESS Main Switch is OFF, all the information will be removed, to prevent the leaking of personal info.
14. App info display speed may be limited due to network transfer rate, therefore resulting in slow data indication under poor networking speed.
15. There are certain app notice limitations between iOS and Android systems.
16. There is a possibility that app functions may become unusable after upgrading iOS and Android software; some new cell phone models may have unusability issues.

The noodoe system may shut off and enter into protection mode due to excessive temperature rise under certain special environments or modes; however, the system will resume operation when the temperature drops.

6. Correct riding method

Learning the accurate riding method is important for safety and extends the service life of the vehicle.

- (1) Charge the Ionex (Personal / Shared)battery or Core battery fully before riding

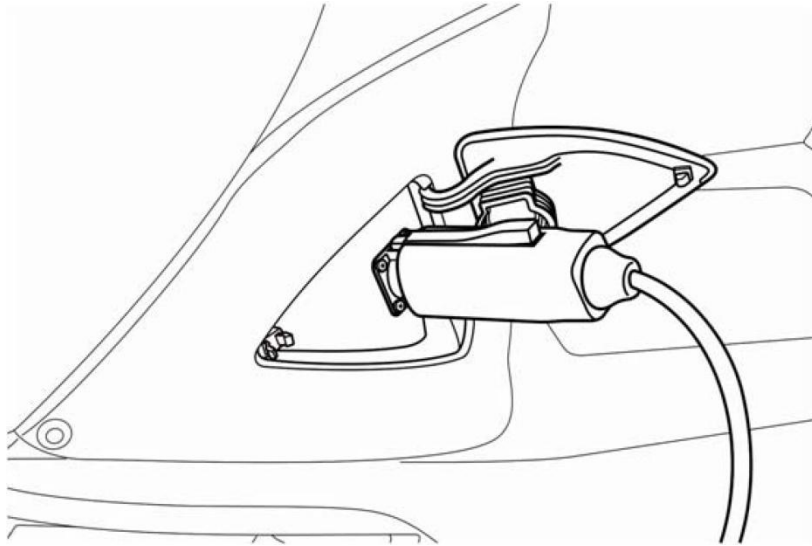

Note

- The charging lid must be put on properly.

During riding

Step on the motorcycle from the left and sit on the seat properly. Place your left foot on the ground to avoid toppling over.



(2) Activating the Main Switch

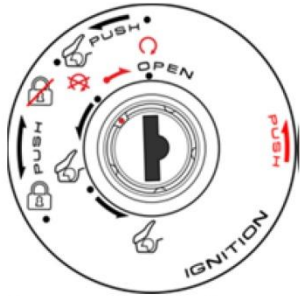

Activating the Main Switch

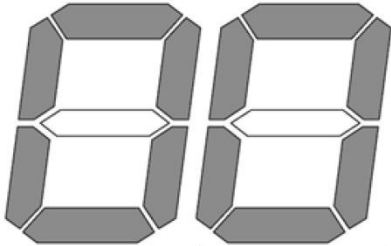

00 is flashing on the speedometer of the meter

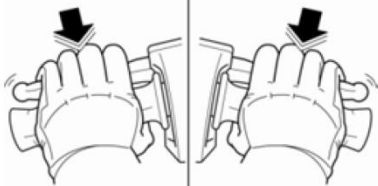

Keep the front or rear brake lever pressed

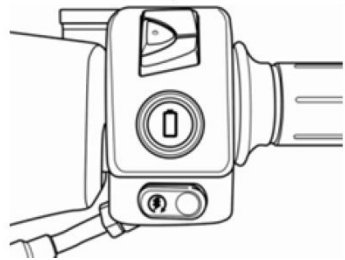

Press the POWER Mode/Start-up Switch

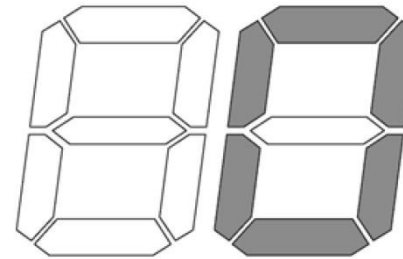

0 is displayed on the speedometer of the meter

Note

- When you activate the Main Switch, the Acceleration Handlebar must return to its original position, or the Acceleration Handlebar will not function properly.
- After turning the switch on, the meter has not shown the activation status screen after turning the switch on and off quickly (within 1 second). (Electricity remains in the meter's capacitor. The meter is considered not shut down.) This is normal.
- After the rear brake is released, do not randomly use the Acceleration Handlebar to prevent your scooter from rushing forward dangerously.

(3) Check of Front-Rear Safety

Turn on the Blinker before starting and check the rear side for safety before riding.

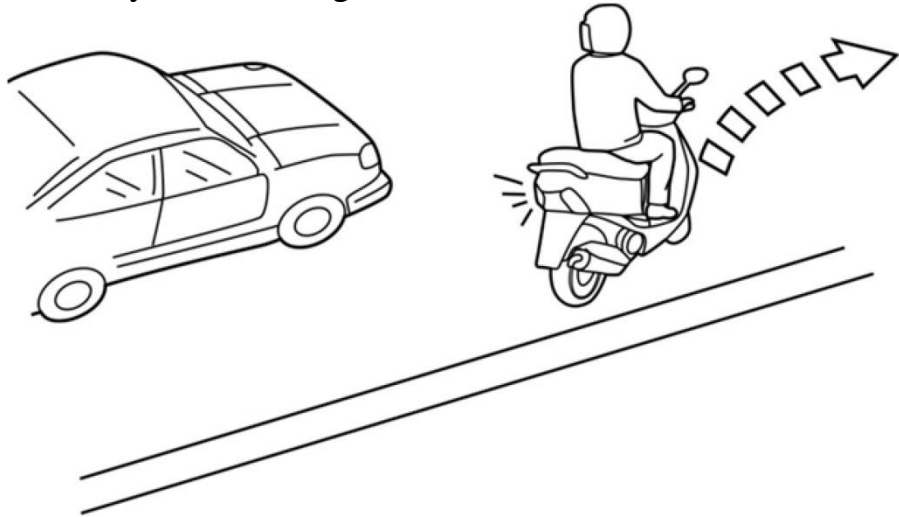

(4) Starting and Acceleration

Release the rear brake lever and turn the Acceleration Handlebar backward slowly. The scooter then starts slowly.

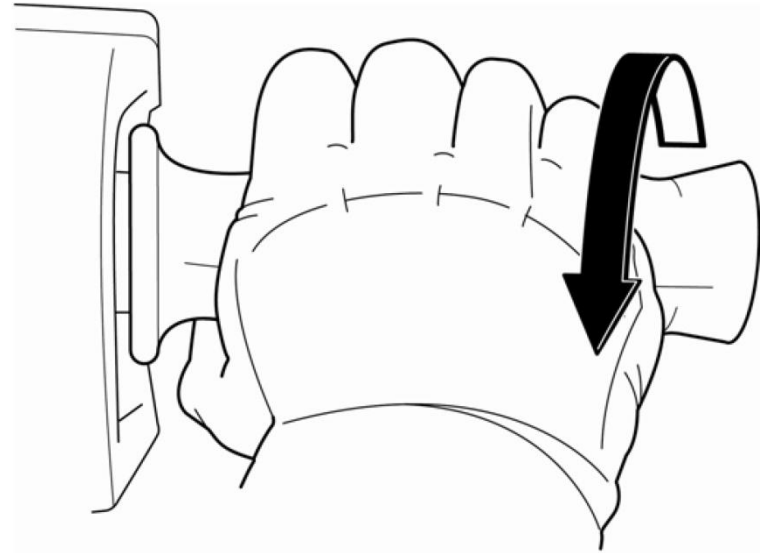

Note

Do not turn the Acceleration Handlebar rapidly to avoid sudden unintended acceleration of the scooter.

(5) Vehicle Speed Control

The Acceleration Handlebar determines the speed

Accelerate => Speed increases

Slowly turn the Acceleration Handlebar backward to increase the current to speed of the scooter.

Resuming => Speed decreases

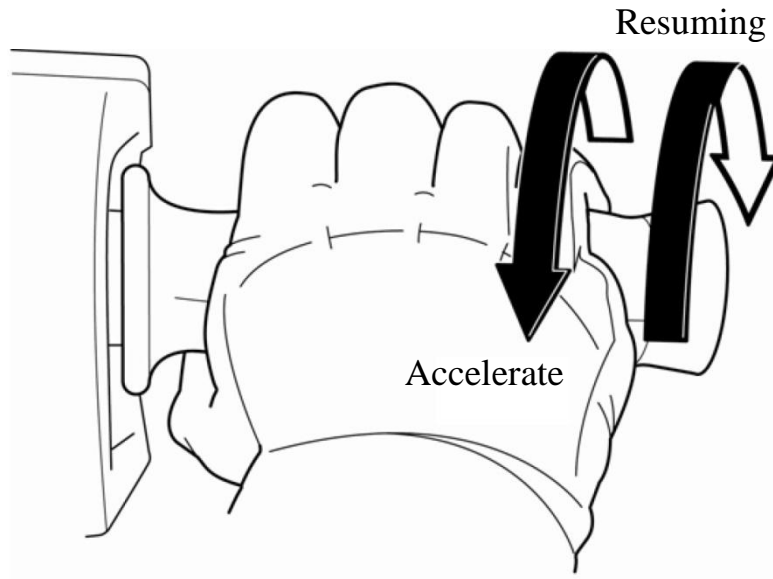

Adequate riding

Follow the manual to extend the service life of vehicle.

 **Note**

- Beware that the vehicle will slip easily and be unstable if braking on one side.
- Follow legal speed and traffic rules and drive safely.

Use the Front and Rear Brake Levers at the Same Time for Braking

Return the Acceleration Handlebar to OFF, and pull the front as well as rear Brake Lever tightly.

The best way to brake is to pull the Brake Lever "slowly" and then tightly.

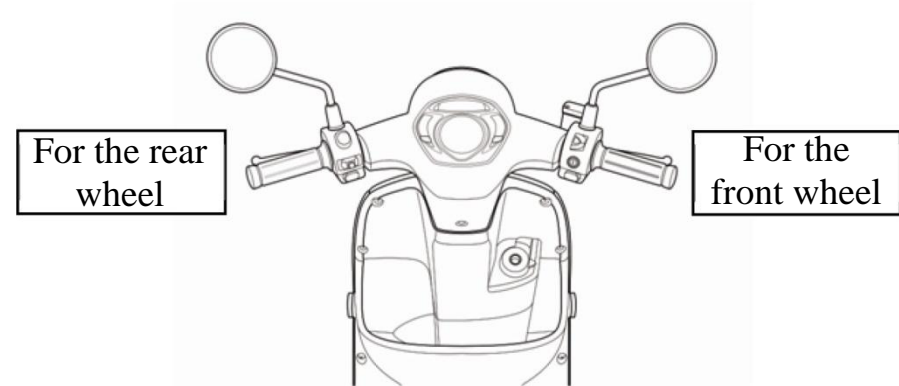

Do not brake or turn abruptly

- Do not brake or turn abruptly unless there is an emergency, otherwise the vehicle will slip or topple over, which is very dangerous.
- Roads are slippery on rainy days. Emergency braking will cause slipping or toppling over, which is very dangerous. Please take precautions.



Take extra cautions when riding on rainy days

The braking distance needed is longer on rainy days than sunny days. You should reduce your speed and take advance actions for braking.

When going downhill, Return the Acceleration Handlebar to OFF, and intermittently break the scooter for slow riding. Avoid driving through areas with ponds or puddles of water where the water level will cover half of the wheel.

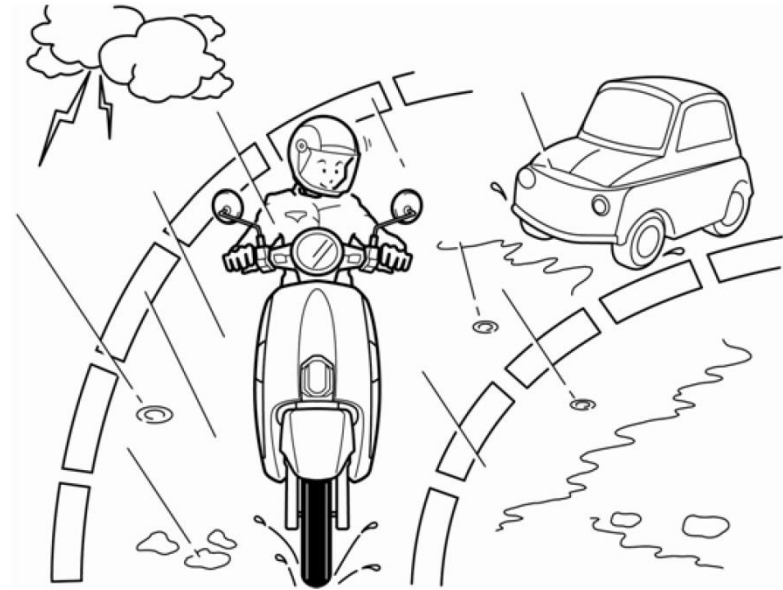

7. Correct Parking Method

(1) When approaching a parking location:

The Blinker blinks and goes off if turned on in advance.

Pay attention to vehicles behind you and on your side. Check for safety and move slowly on the right to park the vehicle.

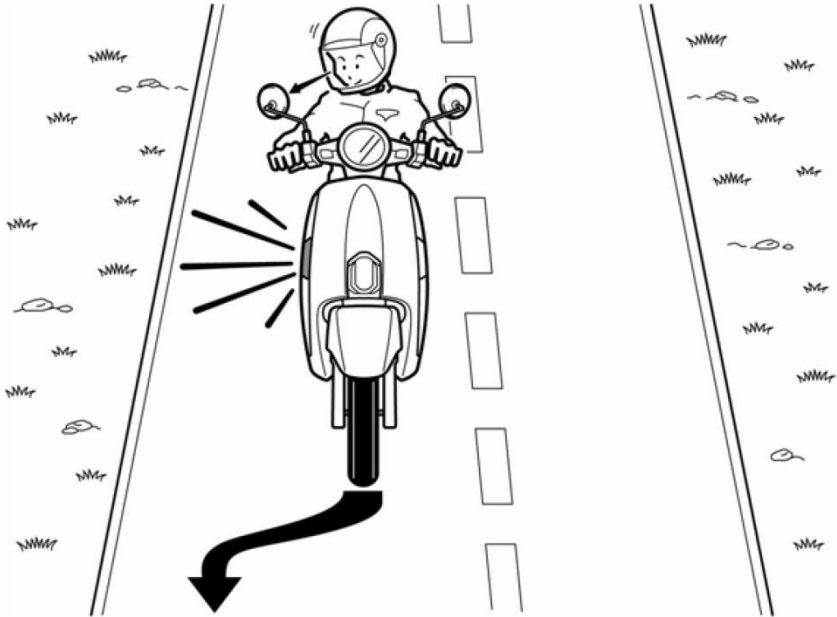

(2) Pulling the Brake Lever Slowly

Return the Acceleration Handlebar to its original position. Slowly pull the front and rear Brake Levers tightly. Do not brake abruptly.

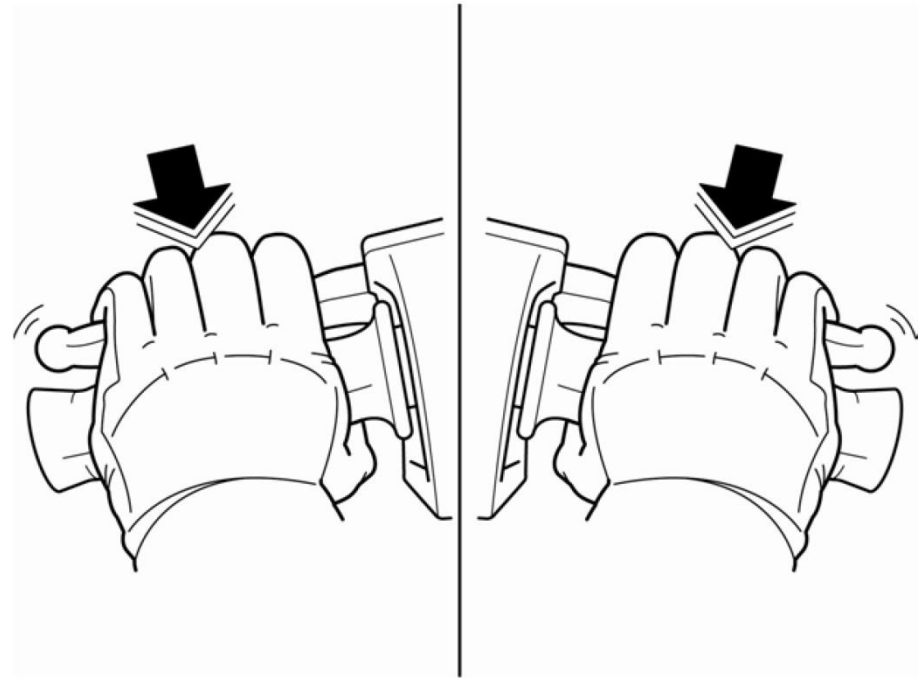

(3) At a full stop of the vehicle

- Place your left foot on the ground and turn off the Blinker Switch. Then turn the Main Switch to “OFF”.

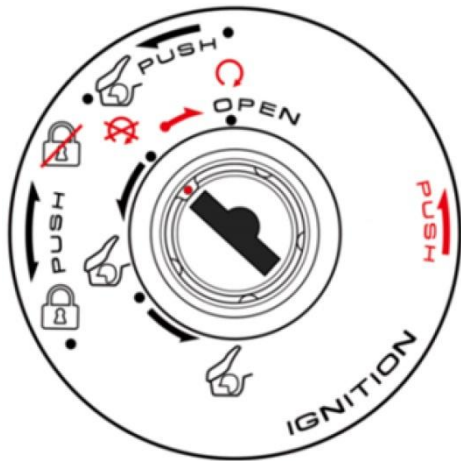

(4) Main Stand

Get off the scooter from the left side. Put down the main stand or side stand on level and flat ground without affecting the traffic.

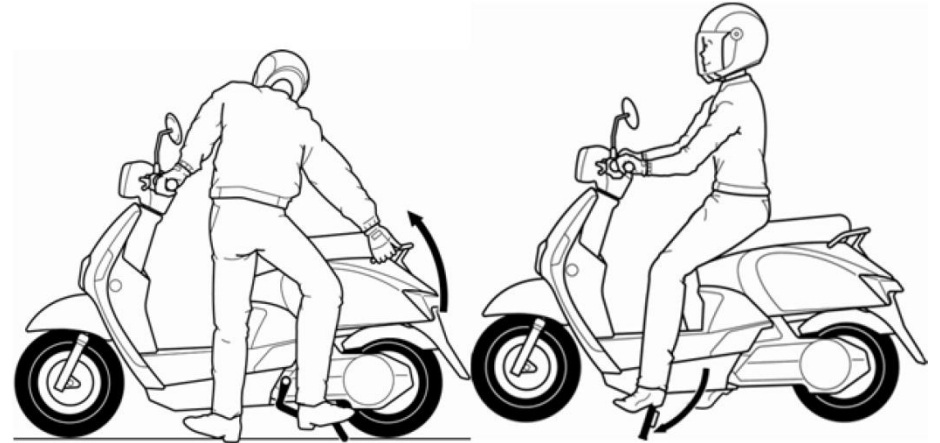

Note

- For safety reasons, do not turn the main switch to “ON” or press the Start-up Switch before mounting the scooter.
- Do not ride the scooter after drinking or taking medicine.

Locking the Handlebar

For theft prevention, lock the handlebar and pull out the key when parking your scooter.

Turn the Main Switch to “LOCK” and gently swing the handlebar to make sure it is locked (refer to steering stem locking)

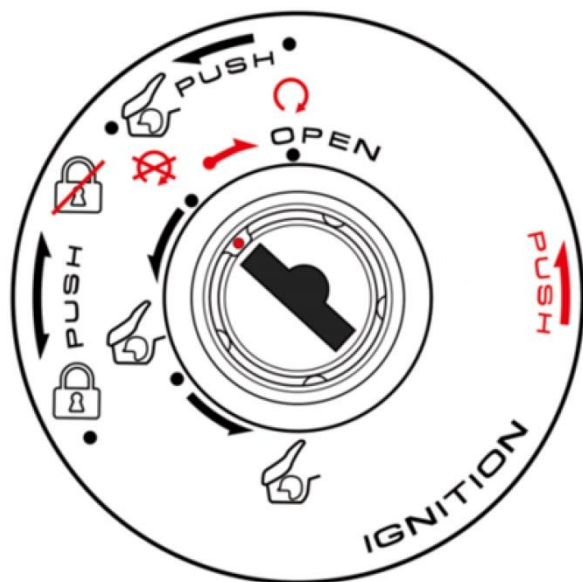

Note

Do not park your scooter in locations where traffic safety may be obstructed.

8. Scooter Charging

Charger Mode

1. Standby mode → Green LED is on
2. Charging mode → Yellow LED is on
3. Error mode → Red LED flashes
4. Charge complete mode → Green LED is on



Note

- During charging, do not touch the hot charger and battery. Do not charge in the luggage box. Keep away from flammable objects, or a fire or battery explosion may occur.
- During charging, it is strictly forbidden to connect or disconnect the “output cable” and terminals of the charger using wet hands. This may cause the risk of electric shock.

The main power source of the scooter is the battery. When you stop the scooter, turn off its power and charge the battery fully.

Scooter Charging Method:

- (1) Turn the Main Switch to “OFF” (Fig. 1).
- (2) Connect the power cable of the charger and plug it into the AC 110v outlet (Fig. 3).
- (3) Open the cover of the Charging Outlet, and connect the output cable of the charger to the Charging Outlet (Fig. 2).
- (4) The charger indicator lights up in yellow (Fig. 4), which means charging in progress. (The charging time varies depending on the battery condition and ambient temperature).
- (5) When the charging indicator changes from yellow to green→illuminated in green, it means the battery is charged completely.

Actions to be taken after charging:

1. Remove the AC 110v power cable.
2. Remove the charger plug.
3. Replace the cover of the Charging Outlet.

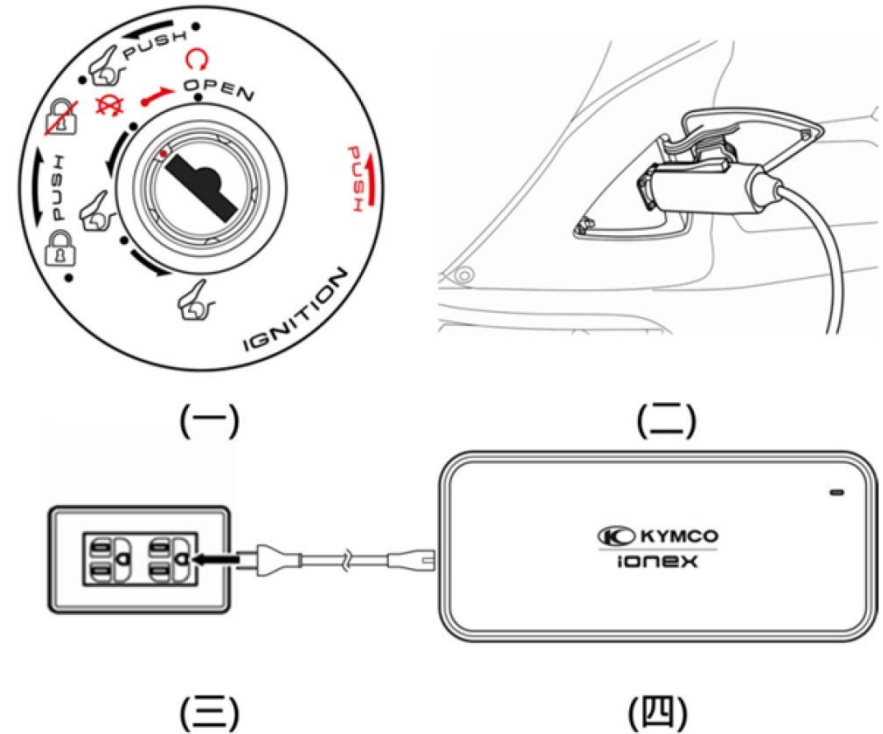

Note

- ◆ Refer to the charging instructions of this Manual.
- ◆ After charging and riding, close the cover of the Charging Outlet.
- ◆ The charger is dedicated for charging of the lithium battery. It is strictly to use it for any other purpose.

 **Note**

- ◆ During the operation of the charger, the charger and battery become hot. This is normal. Please perform charging in a well-ventilated place.
- ◆ The lithium battery has a protection mechanism which stops charging if the temperature is too high. During charging, if the charger does not immediately enter Charging Mode (the indicator lights up in green), this is normal. Please keep the charger plug connected. Charging resumes (the indicator lights up in green) after the battery temperature drops below the protection threshold (the indicator lights up in yellow).
- ◆ You must use the charger from KY when charging your new scooter's new battery or another new battery you buy for the first time. Fully charge the battery (until the green light on the charger is illuminated) to ensure normal battery performance.
- ◆ When the scooter is connected to the charger, the Core battery and Personal battery will be charged.
- ◆ During the operation of the charger, make sure that there are no flammable objects around the charger. It is strictly forbidden to cover the charger with other objects for better cooling effect.
- ◆ During the operation of the charger, it must be properly grounded. The adapter and power cable used must comply with the CNS standards.
- ◆ On a rainy day or when washing your scooter, because the scooter or ground is wet, do not charge it to avoid

accidental electric shock. Do not remove the Ionex (Personal / Shared)battery for charging at this time.

- ◆ During charging, you must use an independent power source. If you need to connect an extension cord for charging, it is strictly forbidden to use it with any other appliances, or a fire may occur.
- ◆ It is strictly forbidden to charge your scooter using the charger and accessories other than the genuine ones.
- ◆ The charging time is affected by ambient temperature. The charging time in winter is longer than in summer.
- ◆ When your electric scooter is charging, do not cover it with a raincoat or other waterproof object.
- ◆ Please charge the vehicle in a well-ventilated area. The charger must not be exposed to the sun. Do not charge the vehicle in areas that are very humid, too dusty, or have lots of dew. Do not charge it near inflammable materials or volatile gases.
- ◆ Try to leave the vehicle in a shady area. Keep it away from heat or fire. Keep it from being soaked or drenched.
- ◆ After charging, do not remove the charger. Do not connect it to the scooter for more than 24 hours to maintain correct function.

battery

Precautions about the use of the lithium battery

1. For storage, the battery pack should be stored in a cool place with a temperature less than 45°C (3 months). For long-term storage, the temperature should be kept below 20°C (1 year) and the battery pack should be fully charged every month to ensure the battery quality.
2. It is forbidden to throw the battery into water directly or dispose of it with waste. To dispose of the battery, you should return it to the authorized shop, or bring it to a recycling site or recycling truck for recycling.
3. Keep the battery set away from the heat. Store the battery set in a shady, ventilated area.
4. The Personal battery Battery/Shared battery/Core battery is only applicable to the electric scooter. Do not use it for any other product, or the quality may be easily affected.
5. Prior to using the battery pack, you should charge it fully with the charger.
6. If the LED of the Personal/Shared battery lights up in red, it should be charged once every 6 months when stored in an environment with 25°C.
7. If the battery leaks or you smell some odor from it, place the malfunctioning battery in a wide and cool place (such as a corridor or pedestrian arcade) until it is stabilized. If the odor becomes slight and there are no more leaks, the malfunctioning battery must be returned to the dealer shop, or call dedicated personnel to dispose

of it. During this period, do not take any actions for the battery pack.

8. The battery pack must not be dropped onto the ground or pierced by sharp objects.
9. Do not disassemble or modify the battery set. Do not use it separately from the product.
10. The ambient temperatures for discharging and charging the battery pack is $-20\sim 75^{\circ}\text{C}$ and $0-50^{\circ}\text{C}$ respectively.
11. When the battery pack is damaged, go to your nearest Kymco Service Center to inspect or replace the battery pack. Do not disassemble it yourself.
12. The capacity output end of the battery set must not contact metal conductors.
13. During the use/transportation/storage of the scooter, always observe each safety rule (especially for the battery) to avoid danger. If you have any questions, contact the authorized shop/Service Center.



Note

During transportation, the battery and scooter should be placed at different locations and securely fixed to avoid damage to the battery, causing danger.

How to use the Personal/Shared battery

1. You must brace the main stand up on level and flat ground.
2. Turn on the Main Switch (Fig. 1) and press the Battery Cartridge Switch to open the Smart energy bay.
3. Remove the Personal/Shared battery from the Smart energy bay, and place it in the battery charging dock (Fig. 2).
4. Plug the charger into the AC 110v outlet (Fig. 3).
5. Connect the output cable of the charger to the battery charging dock (Fig. 2).
6. The charger indicator lights up in yellow (Fig. 4) which means charging is in progress. The LED indicator of the Personal/Shared battery (Fig. 5) is displayed based on the battery capacity*. (The charging time varies depending on the battery condition and ambient temperature.)
7. When the charging indicator changes from yellow to green→illuminated in green, it means the battery is charged completely.

Actions to be taken after charging:

- A. Remove the AC 110v power cable.
- B. Remove the battery and battery charging dock.
- C. Place the battery into the Smart energy bay on the scooter.

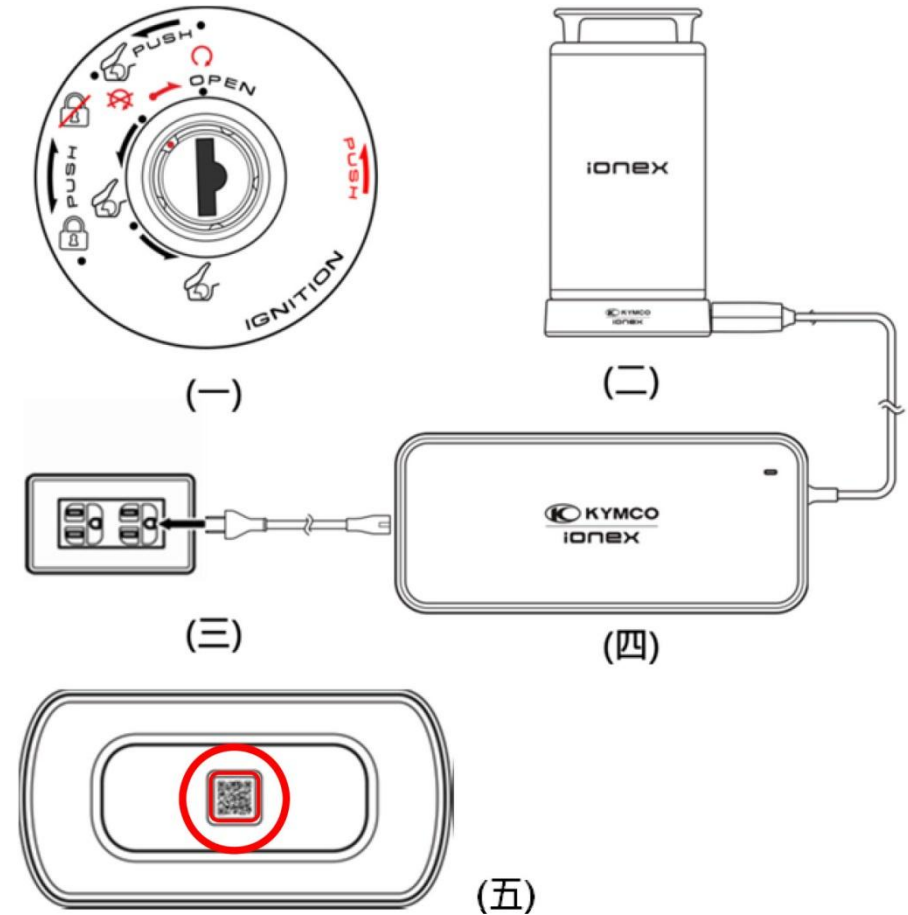

- * The LED indicator above the battery
Green: The capacity is about 75~100%
Yellow: The capacity is about 36~74%
Red: The capacity is about 0~35%

Note

During charging, do not touch the hot charger and battery. Keep away from flammable objects, or a fire or battery explosion may occur.

- When the charger is used for continuous charging, remove the charger power supply after the first battery is fully charged. Then charge the second battery. Do not disassemble or modify the charger without permission.
- During charging, you must use an independent power source. If you need to connect an extension cord for charging, it is strictly forbidden to use it with any other appliances, or a fire may occur.
- It is strictly forbidden to charge your scooter using the charger and accessories other than the genuine ones.
- The charging time is affected by ambient temperature. The charging time in winter is longer than in summer.
- When your electric scooter is charging, do not cover it with a raincoat or other waterproof object.
- Use the genuine battery, charger, and related accessories dedicated for the Kymco Electric Scooter.
- The charger is not included with the scooter. You have the option to rent or purchase it optionally.

9. Battery characteristics

The lithium battery is manufactured specially for the electric scooter with the following characteristics. Please read them carefully.

- (1) The new battery must be charged until the charging indicator turns green and is awake.
- (2) The battery is controlled by the main switch.
The main switch is ON → The battery is activated.
The main switch is OFF → The battery enters Standby mode.
The battery is awake → The main switch is ON.
- (3) When the battery is in a place with a low temperature, its performance will decrease. When you use it in winter, the trip distance allowed by one charging will be shortened.
- (4) It is more difficult to charge the battery in low temperatures, therefore it takes longer.
- (5) After riding, if you want to charge the battery, you cannot charge the battery because its temperature becomes too high. Wait until the battery temperature drops and charge it.

Warning

- Keep the battery set away from children and elders.

- Do not store the battery in an area with high temperatures.
- Do not use the battery set if it acts abnormally, such as presenting leakage, expansion or distortion.

Do not do the following to the battery set, otherwise risks may present:

- (1) Do not short circuit the positive or negative terminal or charge the battery in the reverse direction.
- (2) Do not dismantle or assemble the battery set yourself.
- (3) Do not use any tool to break the battery set apart.
- (4) Do not use the battery set near fire.
- (5) Do not insert long, thin objects into the battery set or hit the battery set with a hammer.
- (6) Do not connect the connector terminal in the reverse direction.
- (7) Do not heat, burn or hit the battery set.
- (8) This is the battery pack dedicated to the electric scooter. Do not use it for any other equipment.



Note

- Read the manual carefully before use.
- When using the battery set for the first time, replace it if it is rusty or smells bad or any other abnormality occurs.
- If you rent a battery, make sure the appearance is intact in accordance with its contract.

Ways to extend the service life of the battery

The service life of the battery vastly depends on how to use it. When you charge the drained battery, you may encounter the following situations:

1. The battery voltage drops and the motor stops.
2. The service life of the battery is reduced.

To improve the performance and service life of the battery, attention should be paid to the following points:

- (1) Develop a habit of charging the battery after each riding (the battery of the scooter does not have the memory effect).
- (2) If your scooter will not be used for an extended period of time, turn the Main Switch to “OFF” and make sure that the battery is fully charged. Charge it once every month.
- (3) The vehicle must be fully charged by the charger after it has not been used for a long time.
- (4) Go to the Kymco authorized shop or Service Center for battery maintenance and inspection on a regular basis.

10. Checks before riding and regular checks

Please check the vehicle before riding for safety and accident prevention.

For the first time check within one month, go to the Kymco Service Center and the authorized shop you bought your scooter.

(1) Checks before Driving.

Carry out a pre-drive check. This is a check required once a day before driving.

- Check any parts with abnormalities from the previous check.
- Check if the gap of the brake lever is normal.
- Check the tires for signs of cracking, damage and abnormal wear. Check if any foreign objects such as metal or pebble chips are in the tire treads.
- Check the depth of tire tread.
- Check the light and blinker.
- Check the angle of the back mirror.
- Check if the reflector is dirty or damaged.
- Check if the acceleration handle is returned.
- Check if the battery is full.
- Check the tire pressure.

(2) Check the parts that were abnormal last time.

- Check if the abnormalities from last time are fixed.
- Check if the gap of the brake lever is normal.

<The gap of the brake lever>

You must leave a proper gap for the brake lever. The “gap” indicates the distance between a released position and the position that feels tight when moving the lever from a released position to a tight position.

The brake lever has a proper gap. Make sure that the lever operates properly.

When checking the end of the brake lever, measure the gap to check if it is within 1-2cm of the specified range.

(3) Check the brake operation.

When riding on a dry road or in low speed, check if the front and rear break levers can brake effectively. (Refer to the Use Front and Rear Brake Levers at the Same Time for Braking)

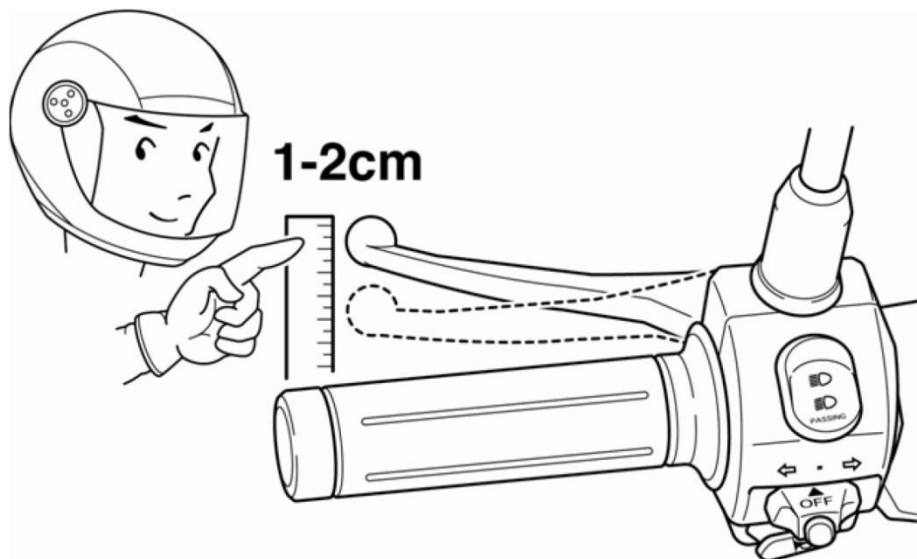

■ Adjustment and inspection of the gap of the brake lever

<Drum brake model>

Use the brake adjustment nut to adjust the gap.

Rotate the adjustment nut during the adjustment.

When adjusting the rear brake lever until it feels tight, check if the gap at the end of the lever is within the specified range.

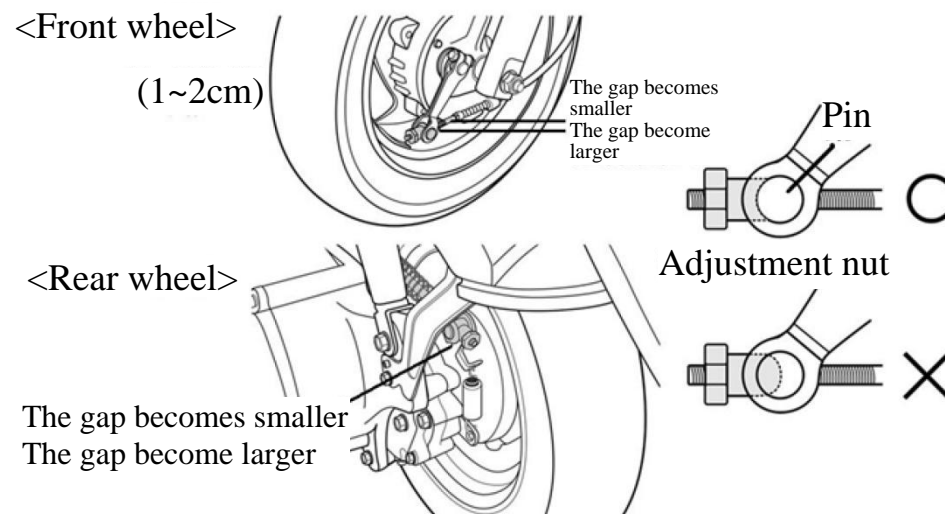

! Warning

After adjusting the brake, adjust the groove of the nut to align it to the pin to avoid danger incurred by the change in the gap.

<Disc brake model>

Check Front/Rear Brake Lining

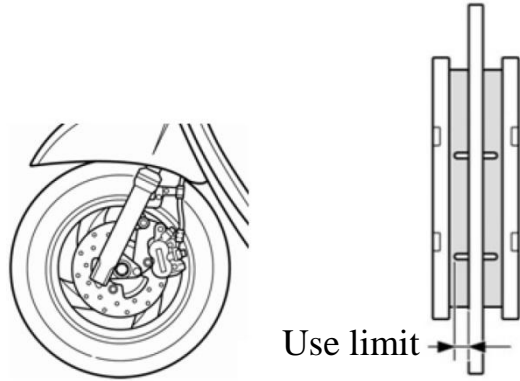

- Is braking effective?
- Verify the braking effect of the front and rear brakes at low speed.

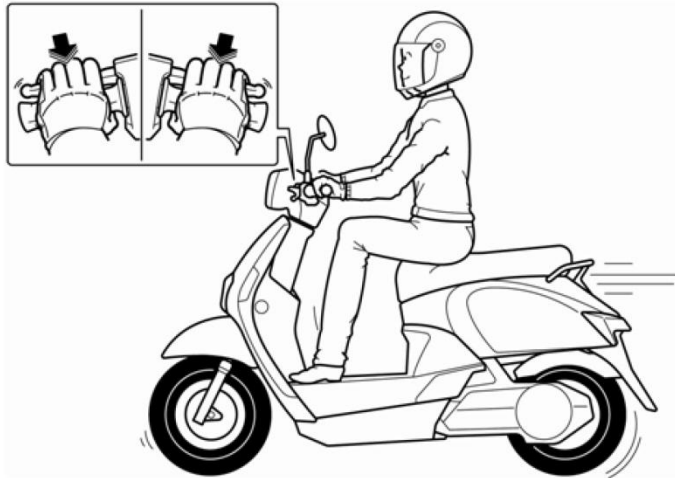

■ Check the Blinker

- Turn the main switch to "ON".
- Operate the Blinker switch to verify if each Blinker flashes and dies out.
- Check the Blinker lens for stains or fractures.

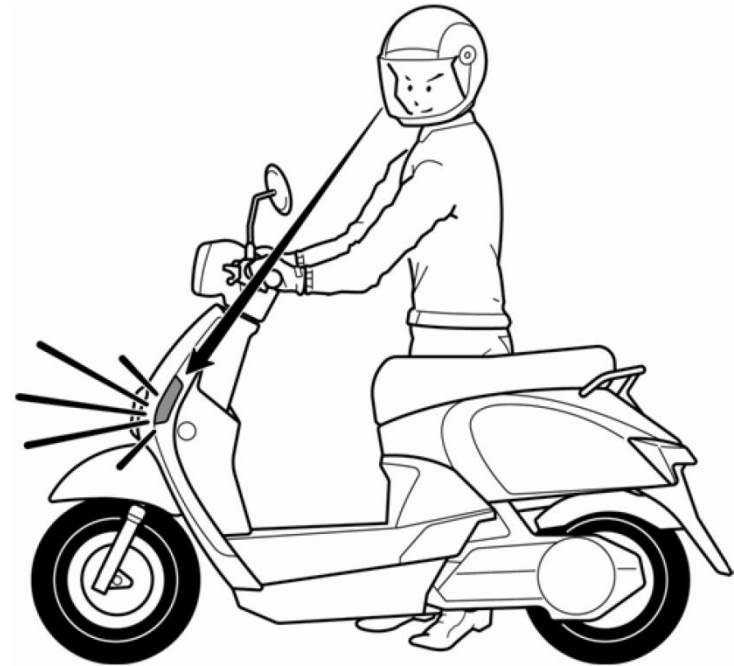

■ Check tires

Check the grip between tire and the ground and normal tire pressure.

In case of a gripping anomaly, check the tire pressure for normal readings using a pressure gauge.

Pressure measurements of cool tire:

	With 1 rider	With 2 riders
Front wheel	1.75kgf/cm ²	1.75kgf/cm ²
Rear wheel	2.00kgf/cm ²	2.25kgf/cm ²



⚠ Note

If you have to replace the rear wheel, it is recommended to use the genuine tires.

Check if metal sheets or stones are caught in the groove. Remove them before riding.

- When a tire cracks or the groove depth reaches the limit of wear, replace it with a new one.

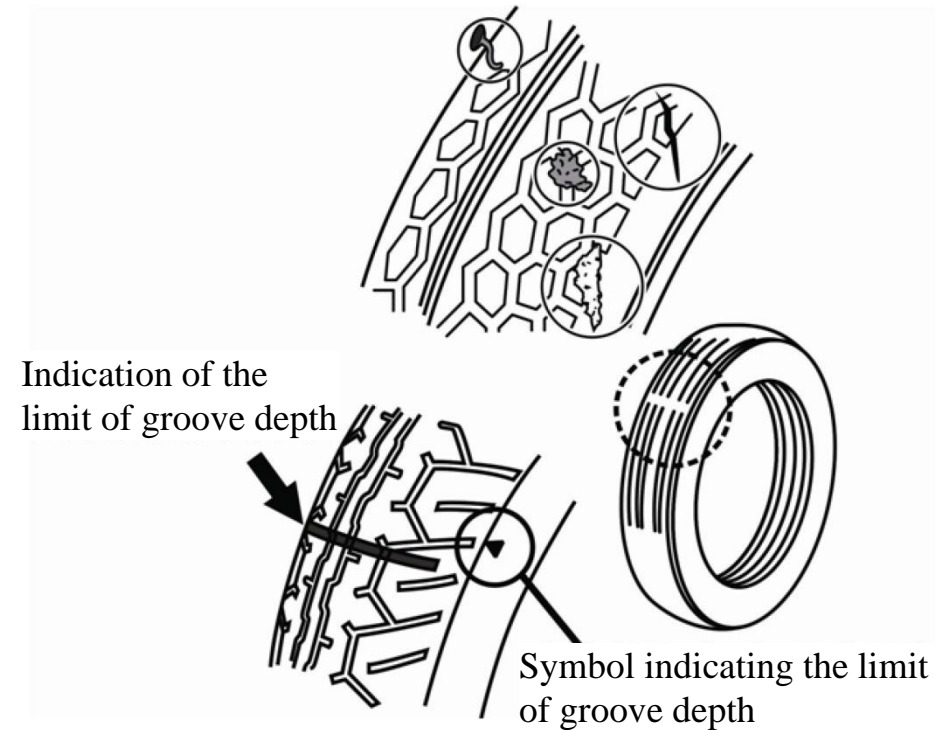

■ Check the lead-acid battery

This vehicle uses a refill-free water battery.

Check the battery voltage:

Use a voltage meter to check if the battery voltage is higher than 12V. If the voltage is too low, remove the battery, and recharge it.

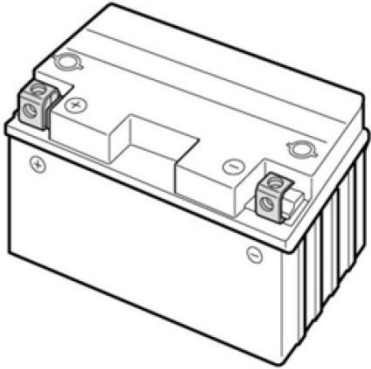

When the battery terminal is rusty, open the seat and remove the battery cover. Clean the battery terminal. After cleaning, apply grease or petrolatum to the battery terminal before installing the battery.

! Note

- When you remove the battery, turn off the main switch first. Then remove the negative wire before removing the positive wire. Connect the positive wire first when installing, then the negative.
- Keep away from naked fire when removing/installing a battery.

■ Change the Gear Oil

<Oil Change Period>

First oil change when running 300 km for a new vehicle, afterwards every half year or 3000 km.

(Recommended gear oil)

KYMCO Gear Oil or SAE90# Gear Oil

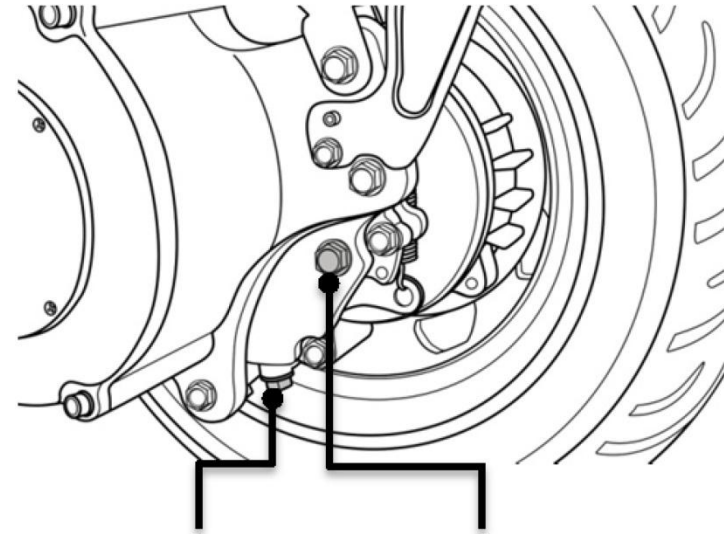

Gear oil drain bolt

Gear oil feeding bolt

Gear oil capacity

Full capacity: 130cc (ml)

Change capacity: 110cc (ml)

<Change Method>

1. Brace the main stand up on level and flat ground.
2. Remove the gear oil drain bolt and gear oil feeding bolt.
3. The gear oil residue in the gear oil tank can be drained out more easily when the motor is stopped.
4. Tighten the drain bolt after cleaning it.
5. Fill in the gear oil from the filler of the gear oil. (The oil is exchanged based on the exchanging capacity of the gear oil.)
6. After filling the gear oil, fasten the filling bolt firmly to prevent the gear oil from leaking.
7. First oil change when running 300 km for a new vehicle, afterwards every half year or 3000 km.

 **Note**

Please change the gear oil often in the following conditions.

- You often ride your scooter on rainy days.
- You ride a long journey for a long time.
- Your scooter carries heavy loads.

(4) Check the Steering Stem

Visually check the steering stem for damage.

Apply the front brake and pull the lever up and down to check if there is any noise.

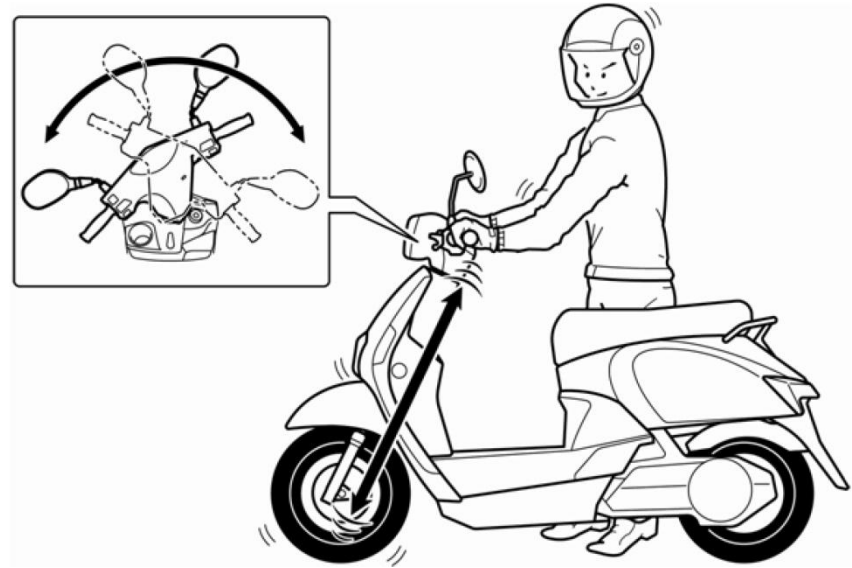

(6) Check if the head light, tail light and blinker goes on normally.

After the main switch is turned ON:

1. Make sure the meter operates or a service code appears (If so, inspect and repair it at the authorized shop or Service Center).
2. After turning on the light switches, check if the head light and tail light are on.
3. After turning on the blinker switch, check if the left and right blinkers are on.
4. Press the horn button to check that the horn is working normally.

(7) Check the back mirror for the proper angle?

Sit on the seat and check the angle of the back mirror. Check if the back mirror is damaged or dirty.

(8) For any others, check if previous anomalies still exist.

 **Note**

- Checking the back mirror improperly will affect safe driving.

(9) Lubrication for All Parts of the Vehicle
Visually inspect that each part of the body is sufficiently lubricated.

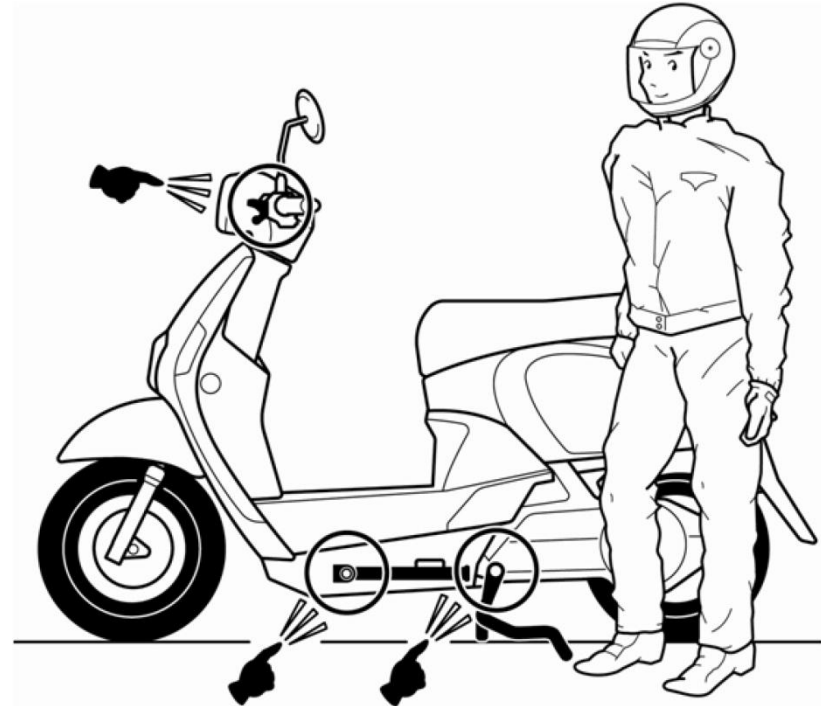

11. During a malfunction

1. When the Main Switch is ON, the meter still shows a service code, even if the previous problem is solved. At this time, restart the Main Switch to clear the service code.
2. If the scooter is broken down when you ride, bring your scooter to a Kymco authorized shop, Service Center, or Kymco EV Scooter Shop for inspection.
3. To avoid personal injury and scooter damage, no personnel other than the Kymco authorized personnel should not inspect and repair the scooter.

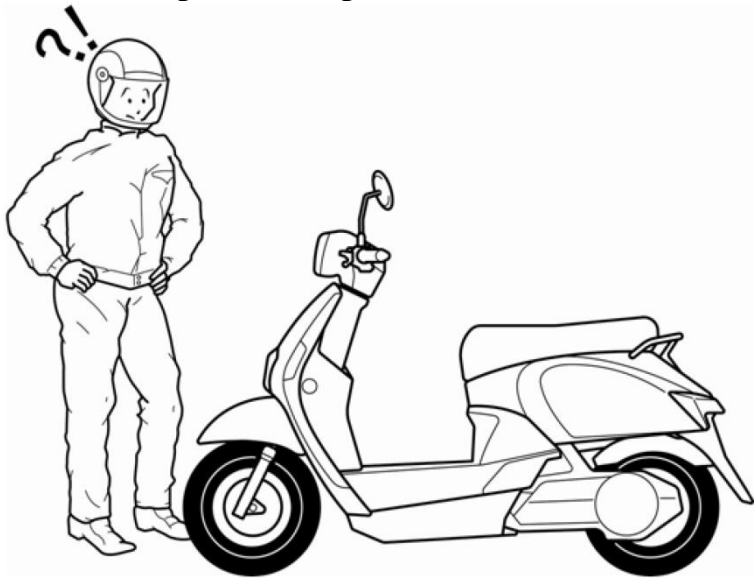

If the motor does not operate

- Turn the Main Switch to “ON” (refer to the main switch positions)
- Is the Core battery or Personal battery fully charged (refer to the meter battery indication)?
- Is the acceleration handlebar returned to the original position (refer to the speed control)
- If the Main Switch is turned to “OFF,” turn it to “ON” again (refer to the main switch positions)
- Check the service code and indicator displayed on the meter panel.

If a malfunction occurs, the motor stops during riding

- Is the battery fully charged (refer to the meter section)? (Make sure the bars displayed on the meter. Charge the battery if necessary)
- Check the fuse.

Note

If a service code appears, go to a Kymco authorized shop, Kymco EV Scooter shop, or Service Center for repairing.

12. Change the fuse

Turn the main switch off to check for a blown fuse.

Only replace it with a fuse of specified capacity.

Identify the cause of a blown fuse before replacing it.

Remove the helmet box. The fuse is in the fuse box next to the voltage converter.

Open the fuse box and pull the fuse out from the fuse clip.

Fuse specifications: four 5A fuses, one 10A fuse and one 30A fuse.

5A/58V: Controller/relay.

5A/58V: Voltage converter.

5A/32V: Main switch/ PO button/Start-up button/Side stand switch/Reverse gear/USB charging.

5A/32V: Meter/Blinker/Relay/Low-Speed horn.

10A/32V: Light/Horn/Brake.

30A/32V: Lead acid battery.

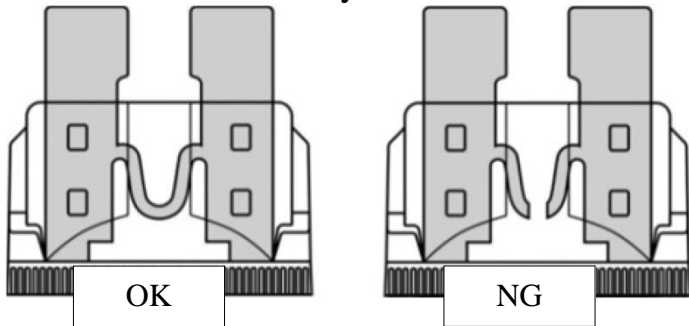

Note

- Removal
Don't overstretch the fuse clip during removal.
- Assembly
Check if the fuse clip is loose after fuse installation. Does the fuse get heated if the fuse clip is loose? This is the main reason for a malfunction. Please be aware of this.
- Do not use a fuse with a capacity outside the specified range. Such fuses are the main reason for overheated and burnt wiring.
- Only replace electrical devices (lights, meters) with original ones of specified ratings.
- If you use a non-genuine fuse or one with different specifications, it will be easily blown with unbalance battery loads.
- If the fuse blows soon after replacement, find out the reason before replacing it again, otherwise it is likely that the fuse will blow again. If you cannot find the reason, go to an authorized shop, or Service Center for inspection.
- Avoid using strong frontal water jets to clean electric parts when cleaning the vehicle.

13. Maintenance List

Please carry out regular maintenance according to this schedule.

I: Inspection; clean, lubricate, replenish, remedy or replace as required. A: Adjustment. C: Cleaning. R: Replace. T: Tightening.

Item	Deadline		Month/Mileage					
	6 months	12 months	18 months	24 months	30 months	36 months	42 months	48 months
	3000 km	6000 km	9000 km	12000 km	15000 km	18000 km	2100 km	24000 km
Gear oil(Note 1)	R	R	R	R	R	R	R	R
Brake oil				I			R	
Computer diagnosis		I		I		I		I
Lubrication of each part (Note 2)	I	I	I	I	I	I	I	I
Operation of each part (Note 3)	I	I	I	I	I	I	I	I

For your safety and warranty terms, it is recommended to perform these tasks at Kymco authorized shop.

- (1) Heavy loads, long journeys, or rainy days may cause poor battery performance. Check or replace the battery as soon as possible.
- (2) Bring the battery pack to the authorized shop or Service Center for inspection every year.
- (3) After 24,000 km, regular inspection should be performed according to the mileage or time (whichever is earlier) listed above.

Note 1. Change gear oil after 300 km for the first time. After that, change gear oil according to the Maintenance List.

Note 2. Lubrication of each part: Side Stand, Main Stand, ...etc.

Note 3. Operation of each part: Tire pressure, tire tread, Battery Cartridge Switch, suspension, Steering Stem, acceleration handlebar, brake system...etc.

14. NEW Many 110 EV Scooter Specifications

Model	EA10UA/EA10UB
Total Length/ Width/ Height	1730mm /670mm /1070mm
Dry Weight/ Ascending Angle	87kg/ 19°
Motor Rated/Max. Power	2300W/3200W
Ionex battery / Core battery	50.4V13Ah / 10Ah
Charger	Input AC 100-240V/50-60Hz/2.3A Output DC 57.4V/3A
Charger Model	3180A-AGD7-900
Drive System	Brushless DC Motor
Brake System	Front Disc and Rear Drum/Front Drum and Rear Drum
Front Tire/Rear Tire	90/90-10 / 90/90-10
Maximum Speed	61km/hr (km/hr)
Controller	Closed loop system/current limit protection/torque feedback
Trip mileage	<p>A. : 60km or less (Ionex (Personal / Shared) Battery *1+ Core battery), one person 75kg, constant speed 30km/hr) °</p> <p>B. : 36km or less (Ionex (Personal / Shared) Battery *1+ Core battery), one person 75kg, this test result id according to the test conditions of CNS.</p> <p>C. : The endurance will vary depending on loading weight, road conditions, riding style, weather and battery conditions, etc.</p>

NFC product specifications

Product name: NFC Reader

Part no.: 36300-AGD7-900

Input: 5V 

Made in Taiwan

 CCAL18LP1700T5 

NEW Many 110 EV Owner's Manual
KWANG YANG MOTOR CO., LTD.

First Edition - 2018 August

Copyright © Do Not Copy

Printed in Taiwan

KYMCO's products sold Taiwan are all designed,
Manufactured, and quality controlled in Taiwan.

