

# TEST REPORT

of

## FCC Part 15 Subpart C

New Application;  Change ID Application;  Class II PC

**Product :** NFC READER ASSY  
**Brand:** KYMCO  
**Model:** 36300-AGD7-900  
**Model Difference:** N/A  
**FCC ID:** 2AOP536300-AGD7-900  
**FCC Rule Part:** §15.225, Cat:DXX  
**Applicant:** Fames Technology Co., Ltd.  
**Address:** 4F No.1 Zhongshan Rd., Tucheng Dist., New Taipei City 236, Taiwan

### Test Performed by:

#### International Standards Laboratory Corp.

<LT Lab.>

\*Site Registration No.

BSMI: SL2-IN-E-0013; MRA TW0997; TAF: 0997; IC: IC4067B-4;

\*Address:

No. 120, Lane 180, Hsin Ho Rd., Lung-Tan Dist., Tao Yuan City 325, Taiwan

\*Tel : 886-3-407-1718; Fax: 886-3-407-1738

Report No.: **ISL-18LR193FNFC**

Issue Date : **2018/10/29**



Test results given in this report apply only to the specific sample(s) tested and are traceable to national or international standard through calibration of the equipment and evaluating measurement uncertainty herein.

This report MUST not be used to claim product endorsement by TAF, NVLAP or any agency of the Government.

This test report shall not be reproduced except in full, without the written approval of International Standards Laboratory Corp..

### VERIFICATION OF COMPLIANCE

**Applicant:** Fames Technology Co., Ltd.  
**Product Description:** NFC READER ASSY  
**Brand Name:** KYMCO  
**Model No.:** 36300-AGD7-900  
**Model Difference:** N/A.  
**FCC ID:** 2AOP536300-AGD7-900  
**Date of test:** 2018/10/02 ~ 2018/10/29  
**Date of EUT Received:** 2018/10/02

#### We hereby certify that:

All the tests in this report have been performed and recorded in accordance with the standards described above and performed by an independent electromagnetic compatibility consultant, International Standards Laboratory Corp.

The test results contained in this report accurately represent the measurements of the characteristics and the energy generated by sample equipment under test at the time of the test. The sample equipment tested as described in this report is in compliance with the limits of above standards.

Test By:           Weitin Chen           Date:           2018/10/29            
*Weitin Chen / Sr. Engineer*

Prepared By:           Elisa Chen           Date:           2018/10/29            
*Elisa Chen / Sr. Engineer*

Approved By:           Dino Chen           Date:           2018/10/29            
*Dino Chen / Sr. Engineer*

## Version

Version No.	Date	Description
00	2018/10/29	Initial creation of document

## Uncertainty of Measurement

Description Of Test	Uncertainty
Conducted Emission (AC power line)	2.586 dB
Field Strength of Spurious Radiation	<=30MHz: 2.96dB 30-1GHz: 4.22 dB 1-40 GHz: 4.08 dB
Conducted Power	2.412 GHz: 1.30 dB 5.805 GHz: 1.55 dB
Power Density	2.412 GHz: 1.30 dB 5.805 GHz: 1.67 dB
Frequency	0.0032%
Time	0.01%
DC Voltage	1%

## Table of Contents

<b>1</b>	<b>GENERAL INFORMATION .....</b>	<b>5</b>
1.1	PRODUCT DESCRIPTION .....	5
1.2	RELATED SUBMITTAL(S) / GRANT (S) .....	6
1.3	TEST METHODOLOGY.....	6
1.4	TEST FACILITY .....	6
1.5	SPECIAL ACCESSORIES.....	6
1.6	EQUIPMENT MODIFICATIONS .....	6
<b>2</b>	<b>SYSTEM TEST CONFIGURATION .....</b>	<b>7</b>
2.1	EUT CONFIGURATION.....	7
2.2	EUT EXERCISE .....	7
2.3	TEST PROCEDURE.....	7
2.4	LIMITATION .....	8
2.5	CONFIGURATION OF TESTED SYSTEM.....	10
<b>3</b>	<b>SUMMARY OF TEST RESULTS .....</b>	<b>11</b>
<b>4</b>	<b>DESCRIPTION OF TEST MODES .....</b>	<b>11</b>
<b>5</b>	<b>CONDUCTED EMISSIONS TEST .....</b>	<b>12</b>
5.1	MEASUREMENT PROCEDURE: .....	12
5.2	TEST SET-UP (BLOCK DIAGRAM OF CONFIGURATION) .....	12
5.3	MEASUREMENT EQUIPMENT USED: .....	12
5.4	MEASUREMENT RESULT: .....	12
<b>6</b>	<b>RADIATED EMISSION TEST .....</b>	<b>13</b>
6.1	MEASUREMENT PROCEDURE.....	13
6.2	TEST SET-UP (BLOCK DIAGRAM OF CONFIGURATION) .....	13
6.3	MEASUREMENT EQUIPMENT USED: .....	14
6.4	FIELD STRENGTH CALCULATION .....	14
6.5	MEASUREMENT RESULT .....	15
<b>7</b>	<b>FREQUENCY TOLERANCE .....</b>	<b>18</b>
7.1	MEASUREMENT PROCEDURE.....	18
7.2	TEST SET-UP (BLOCK DIAGRAM OF CONFIGURATION) .....	18
7.3	MEASUREMENT EQUIPMENT USED: .....	18
7.4	MEASUREMENT RESULTS.....	18

# 1 General Information

## 1.1 Product Description

Product Name	NFC READER ASSY
Brand Name	KYMCO
Model Name	36300-AGD7-900
Model Difference	N/A.
Power Supply	5Vdc from car battery

NFC:

Operating Frequency	13.56MHz
Transmit Power	104.97 dBuV/m Peak at 3m
Number of Channels	1
Antenna Type	Printed Antenna
Module Type	ASK

The Test report is applied for NFC.

**Remark:** The above DUT's information was declared by manufacturer. Please refer to the specifications or user's manual for more detailed description.

## 1.2 Related Submittal(s) / Grant (s)

This submittal(s) (test report) is intended for FCC ID: 2AOP536300-AGD7-900 filing to comply with Section 15.225 of the FCC Part 15, Subpart C Rules.

## 1.3 Test Methodology

Both conducted and radiated testing were performed according to the procedures in ANSI 63.4: 2014. Radiated testing was performed at an antenna to EUT distance 3 meters. Radiated testing was performed at an antenna to EUT distance 3 meters.

## 1.4 Test Facility

The measurement facilities used to collect the 3m Radiated Emission and AC power line conducted data are located on the address of **International Standards Laboratory Corp.** <LT Lab.> No. 120, Lane 180, Hsin Ho Rd., Lung-Tan Dist., Tao Yuan City 325, Taiwan which are constructed and calibrated to meet the FCC requirements in documents ANSI 63.4: 2014. FCC Registration Number is: TW0997, Canada Registration Number: 4067B-4.

## 1.5 Special Accessories

Not available for this EUT intended for grant.

## 1.6 Equipment Modifications

Not available for this EUT intended for grant.

## 2 System Test Configuration

### 2.1 EUT Configuration

The EUT configuration for testing is installed on RF field strength measurement to meet the Commissions requirement and operating in a manner which intends to maximize its emission characteristics in a continuous normal application.

### 2.2 EUT Exercise

The EUT (Transmitter) was tested with a test program to fix the Tx frequency that was for the purpose of the measurements. For more information please see test data and APPENDIX 1 for set-up photographs.

### 2.3 Test Procedure

#### 2.3.1 Conducted Emissions

The EUT is a placed on as turn table which is 0.8 m above ground plane. According to the requirements in Section 7 and 13 of ANSI C63.4: 2014. Conducted emissions from the EUT measured in the frequency range between 0.15 MHz and 30MHz using CISPR Quasi-Peak and Average detector mode.

#### 2.3.2 Radiated Emissions

The EUT is a placed on as turn table which is 0.8 m/1.5m(Frequency above 1GHz) above ground plane. The turn table shall rotate 360 degrees to determine the position of maximum emission level. EUT is set 3m away from the receiving antenna which varied from 1m to 4m to find out the highest emission. And also, each emission was to be maximized by changing the polarization of receiving antenna both horizontal and vertical. In order to find out the max. emission, the relative positions of this hand-held transmitter(EUT) was rotated through three orthogonal axes according to the requirements in Section 6 and 11 of ANSI C63.10: 2013.

## 2.4 Limitation

### (1) Conducted Emission

According to section 15.207(a) Conducted Emission Limits is as following.

Frequency range MHz	Limits dB (uV)	
	Quasi-peak	Average
0.15 to 0.50	66 to 56	56 to 46
0.50 to 5	56	46
5 to 30	60	50

Note

- 1.The lower limit shall apply at the transition frequencies
- 2.The limit decreases linearly with the logarithm of the frequency in the range 0.15 MHz to 0.50 MHz.

### (2) Radiated Emission

1. The field strength of any emission within the band 13.553-13.567 MHz shall not exceed 15,848 microvolts/meter at 30 meters. (124dBuV/m at 3m)
2. Within the bands 13.410-13.553 MHz and 13.567-13.710 MHz, the field strength of any emissions shall not exceed 334 microvolts/meter at 30 meters. (90.47dBuV/m at 3m.)
3. Within the bands 13.110-13.410 MHz and 13.710-14.010 MHz the field strength of any emissions shall not exceed 106 microvolts/meter at 30 meters. (80.5dBuV/m at 3m.)
4. The field strength of any emissions appearing outside of the 13.110-14.010 MHz shall not exceed the general radiated emission limits in section 15.209(Intentional Radiators general limit).as below.

Frequency (MHz)	Field strength $\mu\text{V}/\text{m}$	Distance (m)	Field strength at 3m $\text{dB}\mu\text{V}/\text{m}$
1.705-30	30	30	69.54
30-88	100	3	40
88-216	150	3	43.5
216-960	200	3	46
Above 960	500	3	54



- Remark:
1. Emission level in dBuV/m= $20 \log(\mu\text{V}/\text{m})$
  2. Measurement was performed at an antenna to the closed point of EUT distance of meters.
  3. Only spurious frequency is permitted to locate within the Restricted Bands specified in provision of §15.205
  4. Emission spurious frequency which appearing within the Restricted Bands specified in provision of §15.205, then the general radiated emission limits in § 15.209 apply.
  - 5.

Limitation Calculation:

15,848 microvolts/meter at 30 meters = $20 \log(15,848)$  dBuV/m at 30m = 84 dBuV/m at 30m = 124 dBuV/m at 3m

30m to 3m distance correction factor:  $40 \log(30/3) = 40$  dB

### (3) Frequency Tolerance

The frequency tolerance of the carrier signal shall be maintained within +/- 0.01% of the operating frequency over a temperature variation of -20 degrees to +50 degrees C at normal supply voltage, and for a variation in the primary supply voltage from 85% to 115% of the rated supply voltage at a temperature of 20 degrees C. For battery operated equipment, the equipment tests shall be performed using a new battery.

## 2.5 Configuration of Tested System

**Fig. 2-1 Configuration of Tested System**



**Table 2-1 Equipment Used in Tested System**

Item	Equipment	Mfr/Brand	Model/ Type No.	Series No.	Data Cable	Power Cord
1	DC Power Supply	ABM	8185D	NA	NA	Non Shielding

### 3 Summary of Test Results

<b>FCC Rules</b>	<b>Description Of Test</b>	<b>Result</b>
§ 15.207	Conducted Emission	N/A
§ 15.225 (a)-(d)	Radiated Emission	Compliant
§ 15.225 (e)	Frequency Stability	Compliant

### 4 Description of test modes

The EUT was tested when placed vertically on the table and the EUT stay in continuous transmitting mode.

## 5 Conducted Emissions Test

### 5.1 Measurement Procedure:

1. The EUT was placed on a table which is 0.8m above ground plane.
2. Maximum procedure was performed on the six highest emissions to ensure EUT compliance.
3. Repeat above procedures until all frequency measured were complete.

### 5.2 Test SET-UP (Block Diagram of Configuration)

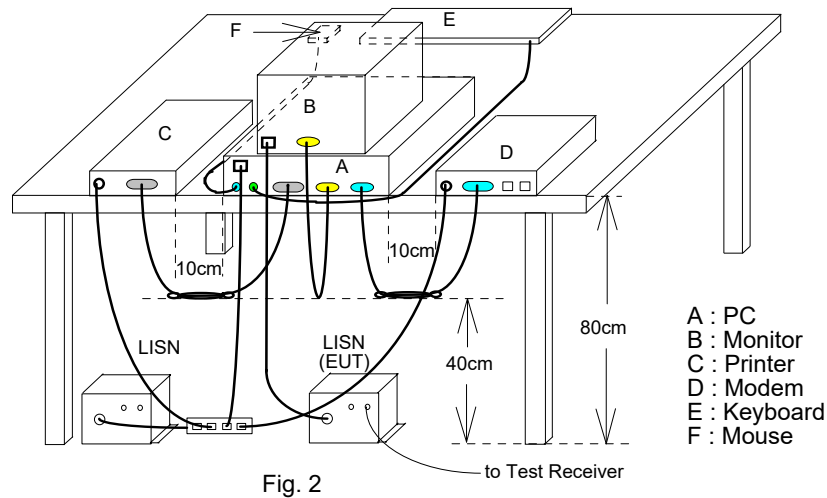

### 5.3 Measurement Equipment Used:

Conducted Emission Test Site					
Equipment Type	MFR	Model Number	Serial Number	Last Cal.	Cal. Due
Conduction 04-3 Cable	WOKEN	CFD 300-NL	Conduction 04 -3	08/30/2018	08/29/2019
EMI Receiver 16	Rohde & Schwarz	ESCI	101221	10/20/2018	10/19/2019
LISN 18	ROHDE & SCHWARZ	ENV216	101424	02/04/2018	02/03/2019
LISN 19	ROHDE & SCHWARZ	ENV216	101425	03/06/2018	03/05/2019
Test Software	Farad	EZEMC Ver:ISL-03A2	N/A	N/A	N/A

### 5.4 Measurement Result:

N/A, the device is powered from car battery.

## 6 Radiated Emission Test

### 6.1 Measurement Procedure

1. The EUT was placed on a turntable which is 0.8m above ground plane.
2. Maximum procedure was performed on the six highest emissions to ensure EUT compliance.
3. And also, each emission was to be maximized by changing the polarization of receiving antenna both horizontal and vertical.
4. Repeat above procedures until all frequency measured were complete.

### 6.2 Test SET-UP (Block Diagram of Configuration)

(A) Radiated Emission Test Set-Up, Frequency Below 30MHz

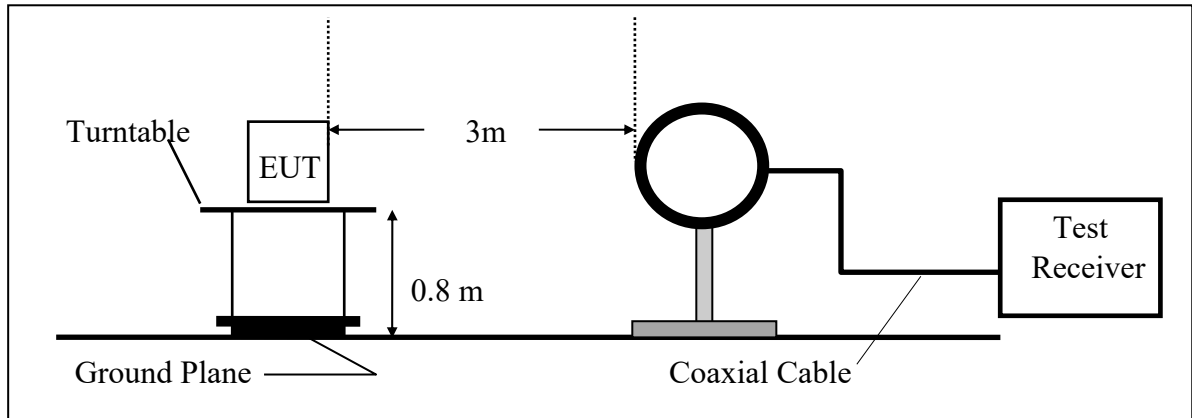

(B) Radiated Emission Test Set-Up, Frequency Below 1000MHz

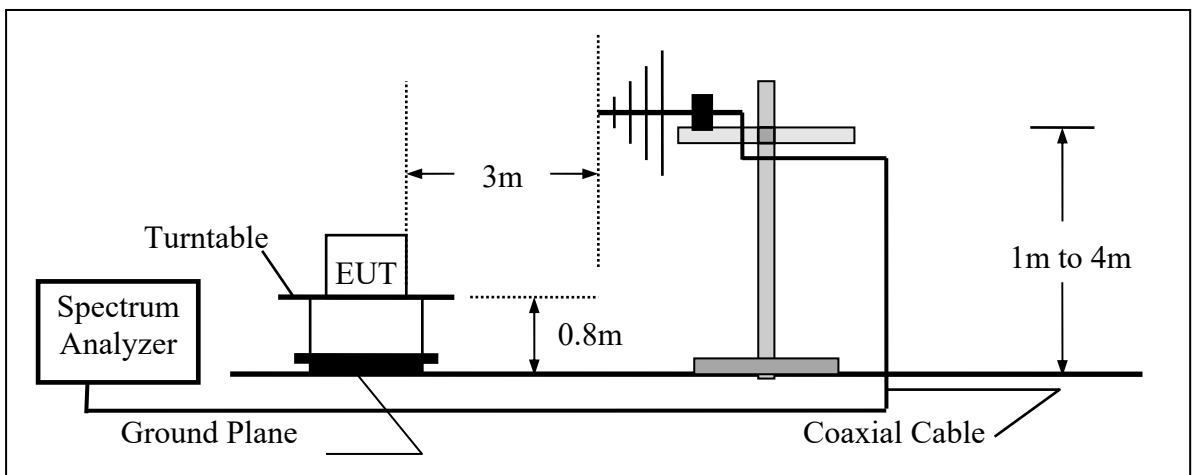

### 6.3 Measurement Equipment Used:

966 Chamber					
Equipment Type	MFR	Model Number	Serial Number	Last Cal.	Cal. Due
966 Chamber	Chance Most	Chamber 19	N/A	08/13/2018	08/12/2019
Spectrum Analyzer 21(3Hz-44GHz)	Agilent	N9030A	MY51360021	11/20/2017	11/19/2018
EMI Receiver	SCHWARZBECK	FCVU1534	1534149	12/07/2017	12/06/2018
Loop Antenna(9K-30M)	EM	EM-6879	271	06/06/2018	06/05/2020
Bilog Antenna (30M-1G)	SCHWARZBECK	VULB9168 w 5dB Att	736	11/16/2017	11/25/2018
Horn antenna (1G-18G)	SCHWARZBECK	9120D	9120D-1627	11/27/2017	11/26/2019
Horn antenna (18G-26G)	Com-power	AH-826	081001	11/21/2017	11/20/2019
Horn antenna (26G-40G)	Com-power	AH-640	100A	02/22/2017	02/21/2019
Preamplifier (9k-1000M)	HP	8447F	3113A04621	12/08/2017	12/07/2018
Preamplifier(1G-26G)	Agilent	8449B	3008A02471	08/23/2018	08/22/2019
Preamplifier (26G-40G)	MITEQ	JS4-26004000-27-5A	818471	11/20/2017	07/21/2019
RF Cable (9k-18G)	HUBER SUHNER	SUCOFLEX 104A	MY1397/4A	11/02/2017	11/01/2018
RF cable (18G-40G)	HUBER SUHNER	Sucoflex 102	27963/2&3742 1/2	11/02/2017	11/01/2018
Turn Table	MF	Turn Table-19	Turn Table-19	N/A	N/A
Mast Tower	MF	JSDES-15A	1308283	N/A	N/A
Controller	MF	MF-7802BS	MF780208460	N/A	N/A
AC power source	T-Power	TFC-1005	40006471	N/A	N/A
Signal Generator	R&S	SMU200A	102330	03/14/2018	03/13/2019
Signal Generator	Anritsu	MG3692A	20311	12/07/2017	12/06/2018
2.4G Filter	Micro-Tronics	Brm50702	76	12/25/2017	12/24/2018

### 6.4 Field Strength Calculation

The field strength is calculated by adding the Antenna Factor and Cable Factor and subtracting the Amplifier Gain and Duty Cycle Correction Factor (if any) from the measured reading. The basic equation with a sample calculation is as follows:

$$FS = RA + AF + CL - AG$$

Where	FS = Field Strength	CL = Cable Attenuation Factor (Cable Loss)
	RA = Reading Amplitude	AG = Amplifier Gain
	AF = Antenna Factor	

## 6.5 Measurement Result

### Fundamental Measurement Result

Operation Mode	: TX mode	Test Date	: 2018/10/15
Fundamental Frequency	: 13.56 MHz	Test By	: Barry
Temp	: 25 °C	Hum.	: 65%

Freq MHz	Reading dBuV	Factor dB/m	Level dBuV/m	Limit dBuV/m	Margin dB	Remark	Pol V/H
13.56	94.21	10.76	104.97	120.00	-15.03	Peak	VERTICAL
13.56	94.21	10.76	104.97	120.00	-15.03	Peak	HORIZONTAL





### 99% Occupied Bandwidth

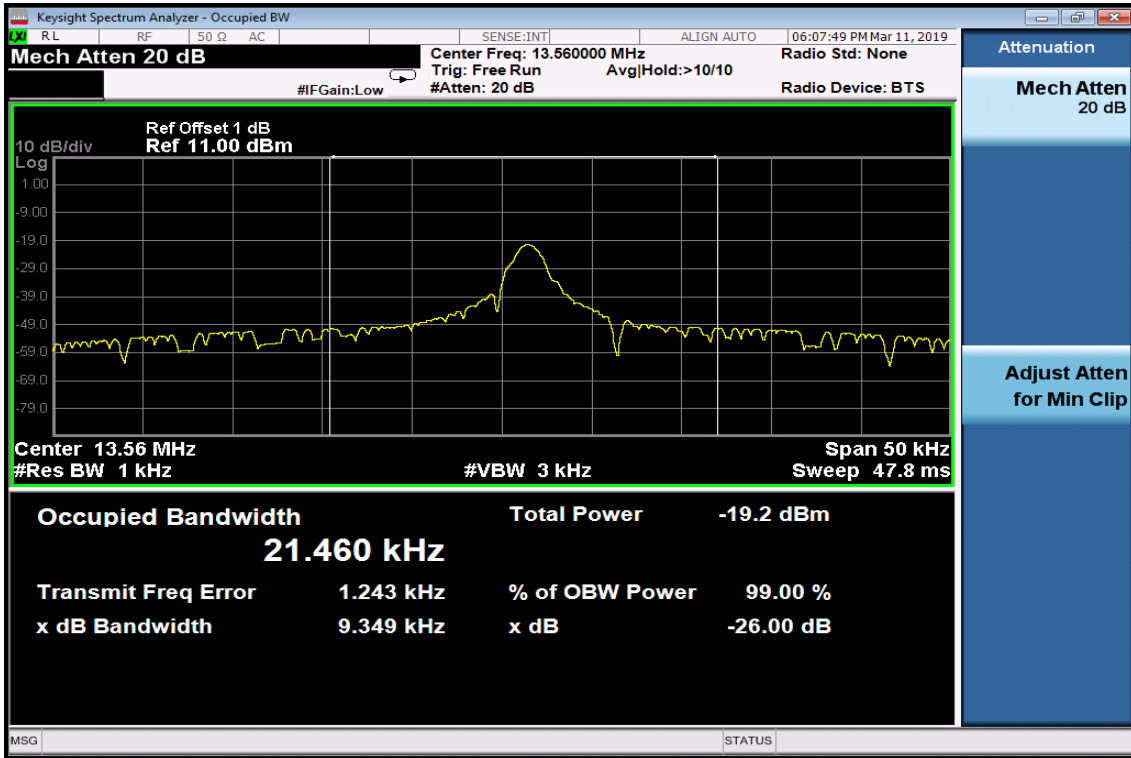

## 7 Frequency Tolerance

### 7.1 Measurement Procedure

1. The EUT was placed on a turn table which is 0.8m above ground plane.
2. Set EUT as normal operation
3. Set SPA Center Frequency = fundamental frequency, RBW, VBW= 10kHz, Span =100kHz.
4. Set SPA Max hold. Mark peak.
- 5.

### 7.2 Test SET-UP (Block Diagram of Configuration)

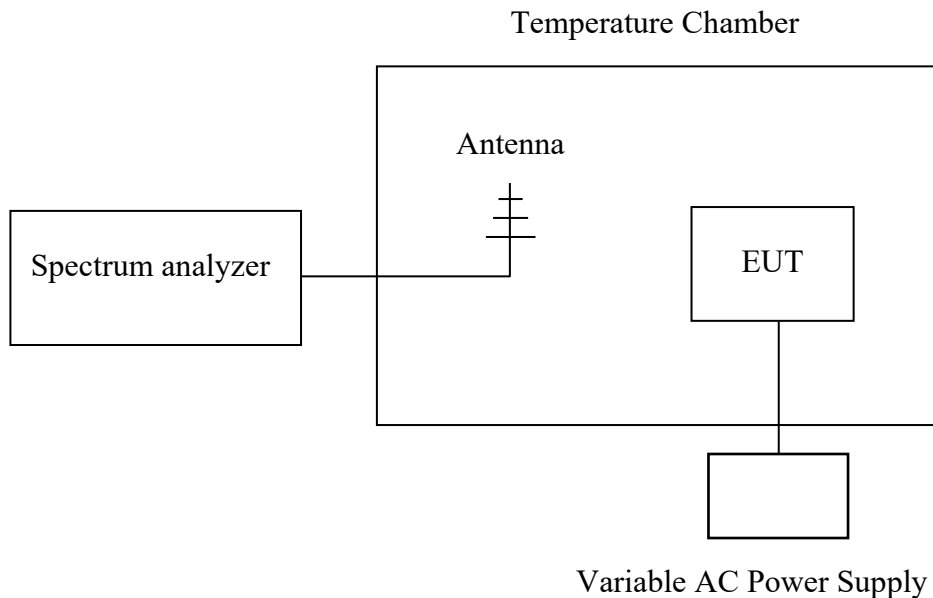

### 7.3 Measurement Equipment Used:

Conducted Emission Test Site					
Equipment Type	MFR	Model Number	Serial Number	Last Cal.	Cal. Due
Spectrum analyzer	keysight	N9010A	MY56070257	07/07/2018	07/06/2019
Spectrum analyzer	R&S	FSP40	100143	11/02/2017	11/01/2018
DC Power supply	ABM	8185D	N/A	11/06/2017	11/05/2018

### 7.4 Measurement Results

Refer to attached data chart.

**A. Temperature Variation**

Limit: +/- 0.01%					
Power Supply	Environment	Frequency	Delta (kHz)	Limit (kHz)	Result
Vdc	Temperature (°C)	(MHz)			
5	-20	13.560081	0.076	1.356	Pass
	-10	13.560035	0.030		Pass
	0	13.560048	0.043		Pass
	10	13.560072	0.067		Pass
	20	13.560005	0.000		Pass
	30	13.560007	0.002		Pass
	40	13.560085	0.080		Pass
	50	13.560051	0.046		Pass

**B. Supply Voltage Variation**

voltage test					
Limit: +/- 0.01%					
Power Supply	Environment	Frequency	Delta (kHz)	Limit (kHz)	Result
Vdc	Temperature (°C)	(MHz)			
5	20	13.560041	0.000	1.356	Pass
5.5	20	13.560033	-0.008		Pass
4.5	20	13.560054	0.013		Pass