

WLT8016 BLE Module

Module specification

V1.2

About this manual

The WLT8016 module specification provides an introduction to the basic functions of the WLT8016 module, including the module's electrical specifications, rf performance, pin size, and reference schematic design. Readers can refer to this document to have a detailed understanding of the overall functional parameters of the module. If you have any questions, please log in <http://www.wi-linktech.com/> to contact our company or customer service.

Revision history

Version information management

The version number	time	Update record	editors
V1.0	2019.09.25	Create a document	LEON
V1.1	2020.03.19	Add instructions	Eric
V1.2	2020.04.07	Update schematic	

Wi-linktechCommunicationTechnologies(Shanghai)Co.,Ltd
directory

About this manual	2
Revision history	2
1. Summary	4
1.1 Functional features	4
1.2 Application fields.....	5
2. Electrical specifications	6
3. Pin description	8
3.1 Pin distribution.....	8
3.2 Pin definition	9
3.3 The UART interface.....	10
4. Reference design.....	11
4.1 Refer to the schematic diagram	11
4.2 Module dimension	12
4.3 Matters needing attention	13
5. Reflux parameter recommendation.....	14
6. Software applications.....	14

1. Summary

1.1 Functional features

WLT8016 is a small size, low cost Bluetooth BLE5.0 standardized pass-through module developed by Wi-linktech.

The features of this module are as follows:

- Built-in high-performance 32-bit MCU, up to 48KB SRAM and 512KB Flash
- Transmission power: 4.38 dBm
- Reception sensitivity: -98 dBm sensitivity
- Support UART, SPI, I2C, I2S ,ADC, PWM, etc
- Support for AT instruction
- Support TRUE Random Number Generator (TRNG) and Hardware AES-128 cryptographic engine
- 16-bit audio codec with max 50mW PA out
- Board high performance PCB antenna
- Stamp hole pin, easy and reliable welding
- Ultra-small package: 11.2x16mm
- 1.8V-4.3V supply voltage range
- Operating temperature: -40°C~+85°C

WLT8016 module only needs to connect VCC, GND, TX, RX four wires to complete data transmission function. And The AT directive is also supported to modify parameters such as the default name (see the WLT8016 manual for details).

After the module configuration is completed, the pass-through function can be

Wi-linktechCommunicationTechnologies(Shanghai)Co.,Ltd

tested with relevant mobile software. Android users can download the official test software "Wi-linktech test software" through Baidu mobile assistant search. Apple users recommend using the light blue of the mobile phone store, as shown in figure 1:

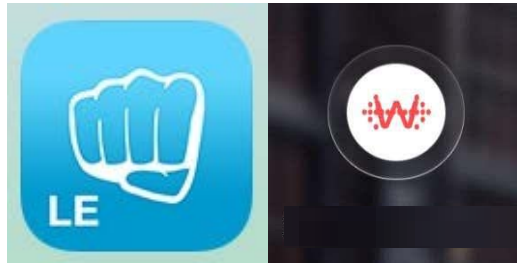

Figure 1

Wi-linktech has been engaged in the Bluetooth field for many years, with strong research and development strength, which can easily realize the interconnection, data transmission and other applications of users' Bluetooth devices. Based on the standard version of WLT8016 module, our company can customize the design of Bluetooth module in accordance with the customer's requirements, and provide corresponding hardware and software support. For details, please contact our company <http://www.wi-linktech.com/> or customer service.

1.2 Application fields

Personal equipment:

Wearable, mouse and keyboard, remote control toys;

Retail logistics:

Electronic shelf label, cold chain transport;

Smart home:

Lighting, sensor, smart lock, remote control, lawnmower, voice control, smart printer, lift desk and chair;

Industrial control:

Security monitoring, special printer, medical equipment;

2. Electrical specifications

■ Absolute Maximum Ratings

Rating		Min	Max	The Unit
Supply Voltage	VCC	1.8	4.3	V
I/O Voltage	ALDO_OUT	2.1	3.5	V
Storage Temperature	Tstr	- 40	105	°C

Note:

- 1) The listed electrical characteristics are the target specifications and are for reference only. Some data may be updated based on actual test results.
- 2) The voltage value shown is based on GND in the module. Any voltage exceeding the "maximum rating" may cause permanent damage to the equipment.

■ Recommended Operating Conditions

The Item	Symbol	Min	Typ.	Max	The Unit
Supply Voltage	VCC	1.8	3.3	4.3	V
I/O Voltage	ALDO_OUT	2.1	2.9	3.3	V
Operating Temperature	Topr	- 40	-	85	°C

■ Power Consumption

The Operation Mode	Business,	Maximum	The Unit
TX peek current (0 dB)		8	mA
RX peek current		9.7	mA
Deep sleep current(include 80K retention RAM)	6.1		μ A
Power off	2.7		μ A

■ Audio CODEC

Digital to Analogue Converter (Mono)					
The PARAMETER	The CONDITIONS	MIN	TYP	MAX	The UNIT
Resolution	-	-	-	20	Bits
From frequency (Fs) *	The synchronized clock	8		48	kHz
SNR (Signal to Noise thewire)	Fin=1kHz B/W=20Hz -- 20KHz a-weighted THD_N<0.01% Fs(8K,16K,32K, 44.1k,48K)		92		dB
Digital Gain	Digital Gain Resolution =	- 48		32	dB
Analogue Gain	Analog Gain Resolution =	0		- 30	dB
The Output voltage	VDDA = 2.9 V		1500		mV
Stopband attenuation		65			dB
Analog to Digital Converter (Mono)					
The PARAMETER	The CONDITIONS	MIN	TYP	MAX	The UNIT
Resolution	-	-	-	16	Bits
From frequency (Fs) *	The synchronized clock	8		48	kHz
Signal to Noise thewire	A - weighted		79		dBFS
	W/O weighting		79		dBFS
Digital Gain	Digital Gain Resolution =	- 48		32	dB
Analogue Gain	Analog Gain Resolution =	0		30	dB

3. Pin description

3.1 Pin distribution

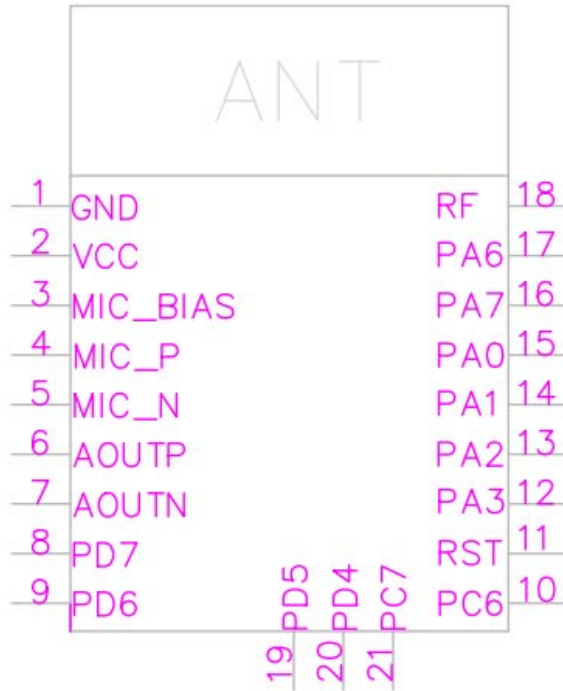

Figure 3-1 pin diagram of the module

Note: pin function in figure 3-1 can be redefined by pin reuse.

3.2 Pin definition

The PIN #	Pin name	type	describe
1	GND	GND	Module to Ground
2	VCC	The POWER	1.8v-4.3v power supply, typical value 3.3v
3	MIC_BIAS	Analog Output	MIC BIAS output
4	MIC_P	Analog Input	Microphone input
5	MIC_N	Analog Input	Common mode voltage
6	AOUTP	Analog Output	Speaker output positive
7	AOUTN	Analog Output	Speaker output negative
8	PD7	The I/O	SDA1/I2SDIN/PWM1/SSPDIN/UTXD0/UTXD1/ANTCTL1 /PD MDAT/PWM0/ADC3
9	PD6	The I/O	SCL1/I2SDOUT/PWM0/SSPDOUT/URXD0/URXD1/CLKOUT/ PDMCLK/PWM1/ADC2
10	PC6	The I/O	SCL1/I2SDOUT/PWM4/SSPDOUT/URXD0/URXD1/SWTCCK/ PDMCLK/PWM5
11	RST	Analog Input	Reset resets the feet
12	PA3	The I/O	SDA1/I2SDIN/PWM3/SSPDIN/UTXD0/UTXD1/ANTCTL1 /PD MDAT/PWM
13	PA2	The I/O	SCL1/I2SDOUT/PWM2/SSPDOUT/URXD0/URXD1/ANTCTL0 /PDMCLK/PWM3
14	PA1	The I/O	SDA0/I2SFRM/PWM1/SSPCSN/UTXD0/UTXD1/ANTCTL0/P DMDAT/PWM0
15	PA0	The I/O	SCL0/I2SCLK/PWM0/SSPCLK/URXD0/URXD1/CLKOUT/ PD MCLK/PWM1
16	PA7	The I/O	SDA1/I2SDIN/PWM1/SSPDIN/UTXD0/UTXD1/ANTCTL0 /PD MDAT/PWM0
17	PA6	The I/O	SCL1/I2SDOUT/PWM0/SSPDOUT/URXD0/URXD1/CLKOUT/ PDMCLK/PWM1
18	RFT	Analog Output	External RF antenna leads out
19	PD5	The I/O	SDA0/I2SFRM/PWM5/SSPCSN/UTXD0/UTXD1/ANTCTL0/P DMDAT/PWM4/ADC1
20	PD4	The I/O	SCL0/I2SCLK/PWM4/SSPCLK/URXD0/URXD1/ANTCTL0 /PD MCLK/PWM5/ADC0
21	PC7	The I/O	SDA1/I2SDIN/PWM5/SSPDIN/UTXD0/UTXD1/SWDIO/P D MDAT/PWM4

3.3 The UART interface

The module supports UART (universal asynchronous transceiver), full duplex transmission and reception via TX and RX interfaces. Support hardware flow control RTS and CTS.

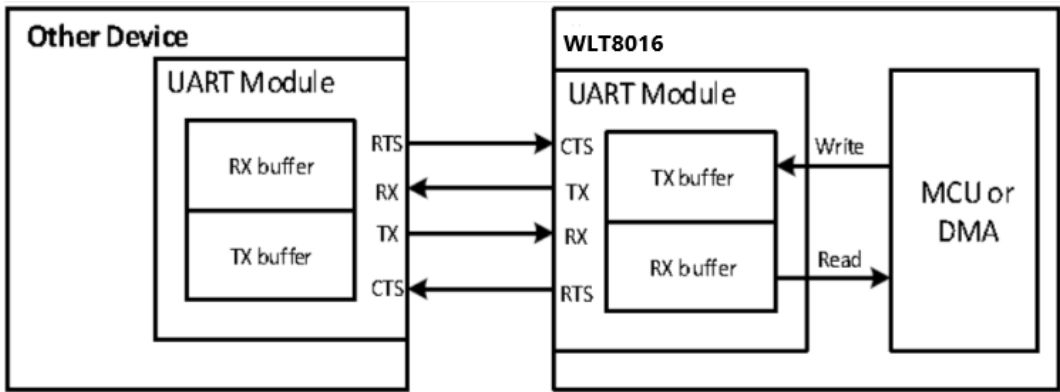

Figure 3-2 UART communication

- As shown in figure 3-2, the sent data is written to the TX buffer, and the UART module transfers the data from the TX buffer through the TX foot. When transferred to other devices, the data received by the RX foot is first sent to the RX buffer and then read through the MCU or DMA.
- If the UART's RX buffer is full, the UART module will send a signal (configurable high or low) through the RTS foot, informing other devices that it should stop sending data. Similarly, UART receives CTS foot signal. Indicates that the RX buffer of other devices is close to full, and UART should stop sending data.

4. Reference design

4.1 Refer to the schematic diagram

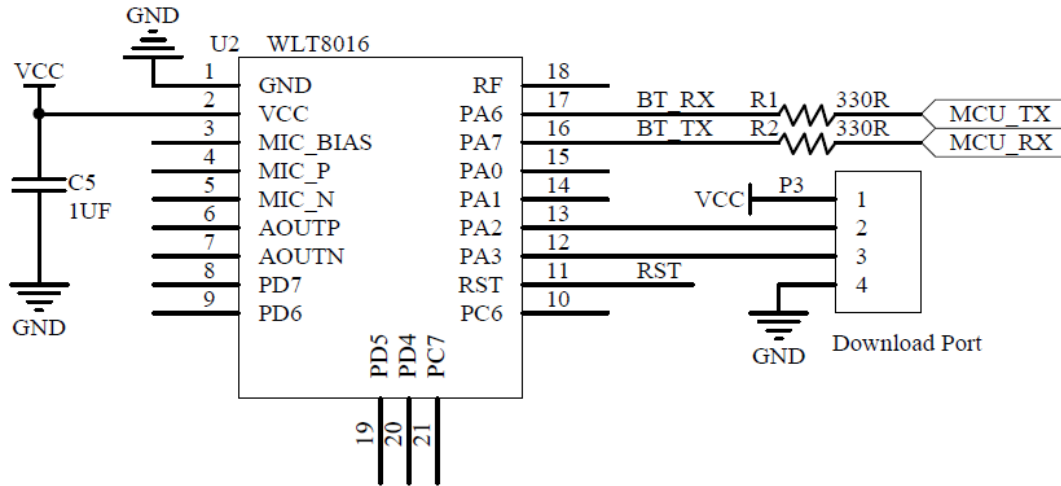

Figure 4-1 Refer to the schematic diagram

4.2 Module dimension

Antenna Area

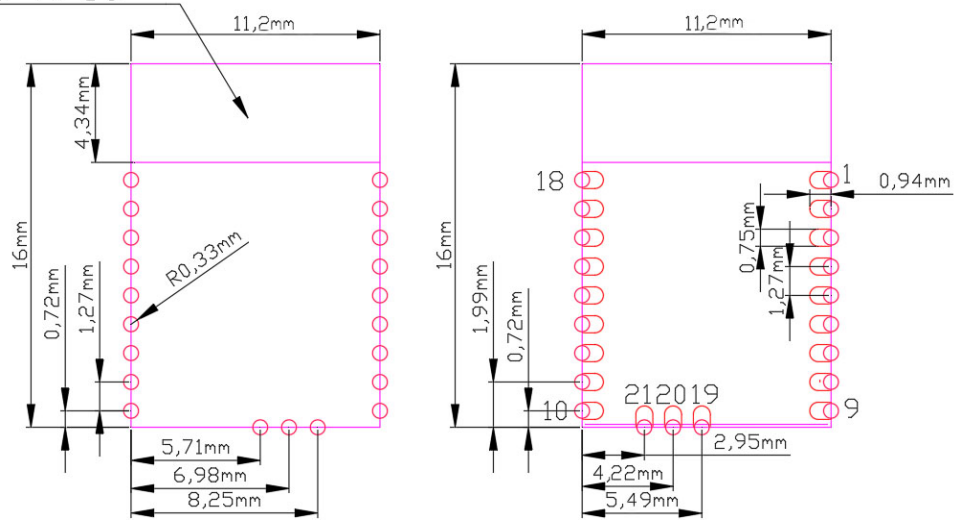

Figure 4-2 Top View (Seen from Top) Bottom View (Seen from Bottom)

Table 4-1 module design dimensions

Module dimensions	Length (X)	11.20 + / - 0.15 mm
	Width (Y)	16.00 + / - 0.15 mm
Antenna position size	Length (X)	The 11.20 mm
	Width (Y)	The 4.34 mm
The thickness of the PCB	Height (H)	0.80 + / - 0.05 mm
Total module thickness (PCB thickness + maximum component height)	Height (H)	2.00 mm of typical

Note: Wi-linktech reserves the right to select components from different suppliers to achieve module functions.

Also ensures that all mechanical, electrical and module certifications are maintained. The design shall be performed within the mechanical physical dimensions shown in figure 4-2. All dimensions are in millimeters (mm).

4.3 Matters needing attention

Bluetooth works at the frequency of 2402-2480MHz, so we should try to avoid the influence of various factors on wireless transceiver. Please note the following points:

- Avoid the use of metal in the product enclosure that surrounds the module. If the enclosure is metal, an external antenna should be considered.
- The metal screws inside the product should be kept away from the RF part of the module.
- To maximize RF performance, the user's motherboard layout should follow the following recommendations:
 - 1) Antenna clearance area: the user's main board directly below the antenna area of the module shall not have any copper foil wiring (including power, ground and signal layers).
 - 2) Module location: modules should ideally be arranged in one corner of the user's main board, with the PCB antenna located at the far end of the main board. This position minimizes the clearance area of the antenna.

(Refer to the definition of antenna clearance area in the figure below)

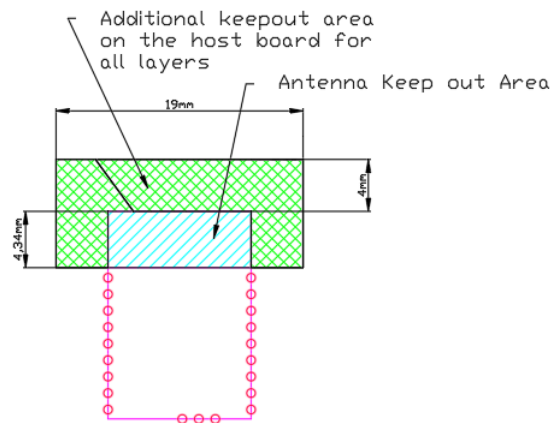

Figure 4-3 Keep out

5. Reflux parameter recommendation

Backflow parameters can refer to the following Settings:

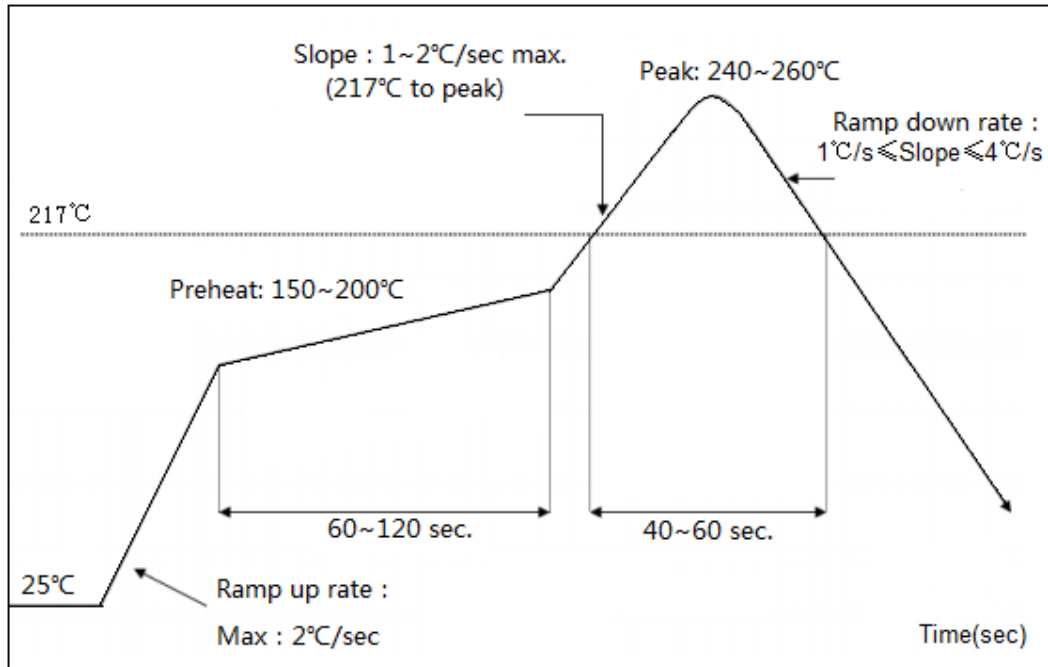

Figure 5-1 reflux recommendation curve

Temperature range	Time	The Key parameters
Preheat zone (< 150 °C)	60-120s	The Ramp up rate: ≤ 2 s
Uniform temperature zone(150-200°C)	60-120s	The Ramp up rate: < 1 s
The Recirculation zone (> 217°C)	40-60s	Peak: 240-260°C
Cooling zone	The Ramp down rate: 1°C/s ≤ Slope ≤ 4°C/s	

Table 5-1 recommended parameters for reflux

6. Software applications

WLT8016 is a data transfer module that supports transparent transfer mode and command transfer mode.

AT+ instruction set mode is that users input commands through the serial port to configure parameters. For detailed commands, please refer to the application documents of relevant WLT8016 module software.

WLT8016 supports customer customization. Please contact our company for details.

7. Regulatory Module Integration Instructions

List of applicable FCC rules

This device complies with part 15.247 of the FCC Rules.

Limited module procedures

Not applicable

Summarize the specific operational use conditions

This module can be applied in remote control toys, sports and fitness sensors , health sensors, mobile accessories as well as smart home. The input voltage to the module should be nominally 1.8-4.3 V DC , typical value 3.3V DC and the ambient temperature of the module should not exceed 85°C.

Trace antenna designs

Not applicable

RF exposure considerations

The equipment complies with FCC radiation exposure limits set forth for an uncontrolled environment. This equipment should be installed and operated with minimum distance 20cm between the radiator and your body. If the equipment built into a host as a portable usage, the additional RF exposure evaluation may be required as specified by 2.1093.

Antennas

This module using PCB antenna with maximum gain is 3 dBi .

Label and compliance information

An exterior label on OEM's end product can use wording such as the following:
"Contains Transmitter Module FCC ID: 2A006-WLT8016" or
"Contains FCC ID: 2A006-WLT8016"

Information on test modes and additional testing requirements

a) The modular transmitter has been fully tested by the module grantee on the required number of channels, modulation types, and modes, it should not be necessary for the host installer to re-test all the available transmitter modes or settings. It is recommended that the host product manufacturer, installing the modular transmitter, perform some investigative measurements to confirm that the resulting composite system does not exceed the spurious emissions limits or band edge limits (e.g., where a different antenna may be causing additional emissions).

b) The testing should check for emissions that may occur due to the intermixing of emissions with the other transmitters, digital circuitry, or due to physical properties of the host product (enclosure). This investigation is especially important when integrating multiple modular transmitters where the certification is based on testing each of them in a stand-alone configuration. It is important to note that host product manufacturers should not assume that because the modular transmitter is certified that they do not have any responsibility for final product compliance.

c) If the investigation indicates a compliance concern the host product manufacturer is obligated to mitigate the issue. Host products using a modular transmitter are subject to all the applicable individual technical rules as well as to the general conditions of operation in

Wi-linktechCommunicationTechnologies(Shanghai)Co.,Ltd

Sections 15.5, 15.15, and 15.29 to not cause interference. The operator of the host product will be obligated to stop operating the device until the interference has been corrected

The WLT8016 module is based on FR8016HA chip .support standard Bluetooth 5.0 commands. For the testing module on your product, user can refer to specification of the Bluetooth system on how to configure and evaluate the module.This specification can also be found on the official Bluetooth website:

<https://www.bluetooth.org/en-us/specification/adopted-specifications>.

Additional testing, Part 15 subpart B disclaimer

The final host / module combination need to be evaluated against the FCC Part 15B criteria for unintentional radiators in order to be properly authorizedfor operation as a Part 15 digital device .

The host integrator installing this module into their product must ensure that the final composite product complies with the FCC requirements by a technical assessment or evaluation to the FCC rules, including the transmitter operation and should refer to guidance in KDB 996369.

Frequency spectrum to be investigated

For host products with certified modular transmitter, the frequency range of investigation of the composite system is specified by rule in Sections 15.33(a)(1) through (a)(3), or the range applicable to the digital device, as shown in Section 15.33(b)(1), whichever is the higher frequency range of investigation.

Operating the host product

When testing the host product, all the transmitters must be operating.The transmitters can be enabled by using publicly-available drivers and turned on, so the transmitters are active. In certain

Wi-linktechCommunicationTechnologies(Shanghai)Co.,Ltd

conditions it might be appropriate to use a technology-specific call box (test set) where accessory devices or drivers are not available.

When testing for emissions from the unintentional radiator, the transmitter shall be placed in the receive mode or idle mode, if possible. If receive mode only is not possible then, the radio shall be passive (preferred) and/or active scanning. In these cases, this would need to enable activity on the communication BUS (i.e., PCIe, SDIO, USB) to ensure the unintentional radiator circuitry is enabled. Testing laboratories may need to add attenuation or filters depending on the signal strength of any active beacons (if applicable) from the enabled radio(s). See ANSI C63.4, ANSI C63.10 and ANSI C63.26 for further general testing details.

The product under test is placed into a normal 'paired' mode with another BLE device, as per the normal intended use of the product (for example, transferring data).

FCC Statement

Any Changes or modifications not expressly approved by the party responsible for compliance could void the user's authority to operate the equipment. This device complies with part 15 of the FCC Rules. Operation is subject to the following two conditions: (1) This device may not cause harmful interference, and (2) This device must accept any interference received, including interference that may cause undesired operation.