

FCC 47 CFR PART 15 SUBPART E

CERTIFICATION TEST REPORT

For

DR.PENG Cloud Meeting

MODEL No.: D*3*4* (*=A-Z,0-9)**

FCC ID: 2AONY-DE3146

Trade Mark: Damai

REPORT NO.: ES170705005E4

ISSUE DATE: February 27, 2018

Prepared for

**Damai Entertainment LLC
980 Corporate Center Dr., Pomona, CA91768, USA**

Prepared by

EMTEK(SHENZHEN) CO., LTD.

**Bldg 69, Majialong Industry Zone, Nanshan District,
Shenzhen, Guangdong, China
TEL: 86-755-26954280
FAX: 86-755-26954282**

1 TEST RESULT CERTIFICATION

Applicant:	Damai Entertainment LLC 980 Corporate Center Dr., Pomona, CA91768, USA
Manufacturer:	Damai Entertainment LLC 980 Corporate Center Dr., Pomona, CA91768, USA
Product Description:	DR.PENG Cloud Meeting
Model Number:	D*3*4*** (*=A-Z,0-9) (Note: all the model numbers are identical in circuitry and electrical, mechanical and physical construction; the only differences are the appearance and colour and model no. , for trading purpose. We take DE3146US to test.)
Trade Mark:	Damai
File Number:	ES170705005E4
Date of Test:	July 05, 2017 to February 27, 2018

Measurement Procedure Used:

APPLICABLE STANDARDS	
STANDARD	TEST RESULT
FCC 47 CFR Part 2, Subpart J FCC 47 CFR Part 15, Subpart E	PASS

The above equipment was tested by EMTEK(SHENZHEN) CO., LTD.. The test data, data evaluation, test procedures, and equipment configurations shown in this report were made in accordance with the procedures given in ANSI C63.10 (2013) and the energy emitted by the sample EUT tested as described in this report is in compliance with the requirements of FCC Rules Part 2 and Part 15.407

The test results of this report relate only to the tested sample identified in this report.

Date of Test : July 05, 2017 to February 27, 2018

Prepared by: 
Doris Su/Editor

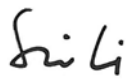
Reviewer: 
Sevin Li /Supervisor

Approve & Authorized Signer : 
Lisa Wang/Manager



TABLE OF CONTENTS

1 TEST RESULT CERTIFICATION2

2 EUT TECHNICAL DESCRIPTION4

3 SUMMARY OF TEST RESULT5

4 TEST METHODOLOGY.....6

4.1 GENERAL DESCRIPTION OF APPLIED STANDARDS6

4.2 MEASUREMENT EQUIPMENT USED6

4.3 DESCRIPTION OF TEST MODES7

5 FACILITIES AND ACCREDITATIONS10

5.1 FACILITIES.....10

5.2 LABORATORY ACCREDITATIONS AND LISTINGS10

6 TEST SYSTEM UNCERTAINTY11

7 SETUP OF EQUIPMENT UNDER TEST12

7.1 RADIO FREQUENCY TEST SETUP12

7.2 RADIO FREQUENCY TEST SETUP12

7.3 CONDUCTED EMISSION TEST SETUP14

7.4 BLOCK DIAGRAM CONFIGURATION OF TEST SYSTEM.....15

7.5 SUPPORT EQUIPMENT.....15

8 TEST REQUIREMENTS16

8.1 BANDWIDTH MEASUREMENT16

8.2 MAXIMUM CONDUCTED OUTPUT POWER.....62

8.3 MAXIMUM PEAK POWER DENSITY67

8.4 FREQUENCY STABILITY99

8.5 UNDESIRABLE RADIATED SPURIOUS EMISSION.....104

8.6 POWER LINE CONDUCTED EMISSIONS.....136

8.7 ANTENNA APPLICATION139

2 EUT TECHNICAL DESCRIPTION

Characteristics	Description																								
Device Type	Wifi 5G Device																								
IEEE 802.11 WLAN Mode Supported	<input checked="" type="checkbox"/> 802.11a(20MHz channel bandwidth) <input checked="" type="checkbox"/> 802.11n(20MHz channel bandwidth) <input checked="" type="checkbox"/> 802.11n(40MHz channel bandwidth) <input checked="" type="checkbox"/> 802.11ac(20MHz channel bandwidth) <input checked="" type="checkbox"/> 802.11ac(40MHz channel bandwidth) <input checked="" type="checkbox"/> 802.11ac(80MHz channel bandwidth)																								
Data Rate	<input checked="" type="checkbox"/> 802.11a:6, 9, 12, 18, 24, 36, 48, 54Mbps; <input checked="" type="checkbox"/> 802.11n(HT20): MCS0-MCS7; <input checked="" type="checkbox"/> 802.11n(HT40): MCS0-MCS7; <input checked="" type="checkbox"/> 802.11ac(HT20): MCS0-MCS7; <input checked="" type="checkbox"/> 802.11ac(HT40):MCS0-MCS9; <input checked="" type="checkbox"/> 802.11ac(VHT80):MCS0-MCS9;																								
Modulation	<input checked="" type="checkbox"/> OFDM with BPSK/QPSK/16QAM/64QAM for 802.11a/g/n; <input checked="" type="checkbox"/> OFDM with BPSK/QPSK/16QAM/64QAM/256QAM for 802.11ac;																								
Operating Frequency Range	<table border="1"> <thead> <tr> <th>Band</th> <th>Mode</th> <th>Frequency Range(MHz)</th> <th>Number of channels</th> </tr> </thead> <tbody> <tr> <td rowspan="3">UNII Band I</td> <td>802.11a/n(HT20)/ac(VHT20)</td> <td>5180-5240</td> <td>4</td> </tr> <tr> <td>802.11n(HT40)/ac(VHT40)</td> <td>5190-5230</td> <td>2</td> </tr> <tr> <td>802.11 ac(VHT80)</td> <td>5210</td> <td>1</td> </tr> <tr> <td rowspan="3">UNII Band III</td> <td>802.11a/n(HT20)/ac(VHT20)</td> <td>5745-5825</td> <td>5</td> </tr> <tr> <td>802.11n(HT40)/ac(VHT40)</td> <td>5755-5795</td> <td>2</td> </tr> <tr> <td>802.11 ac(VHT80)</td> <td>5775</td> <td>1</td> </tr> </tbody> </table>	Band	Mode	Frequency Range(MHz)	Number of channels	UNII Band I	802.11a/n(HT20)/ac(VHT20)	5180-5240	4	802.11n(HT40)/ac(VHT40)	5190-5230	2	802.11 ac(VHT80)	5210	1	UNII Band III	802.11a/n(HT20)/ac(VHT20)	5745-5825	5	802.11n(HT40)/ac(VHT40)	5755-5795	2	802.11 ac(VHT80)	5775	1
	Band	Mode	Frequency Range(MHz)	Number of channels																					
	UNII Band I	802.11a/n(HT20)/ac(VHT20)	5180-5240	4																					
		802.11n(HT40)/ac(VHT40)	5190-5230	2																					
		802.11 ac(VHT80)	5210	1																					
	UNII Band III	802.11a/n(HT20)/ac(VHT20)	5745-5825	5																					
802.11n(HT40)/ac(VHT40)		5755-5795	2																						
802.11 ac(VHT80)		5775	1																						
Transmit Power Max	UNII Band I for 16.77dBm UNII Band III for 12.96dBm																								
Antenna Type	FPC antenna																								
Smart system	<input checked="" type="checkbox"/> SISO for 802.11a/n <input checked="" type="checkbox"/> MIMO for 802.11n/ac																								
Antenna Gain	2dBi for UNII Band I 2dBi for UNII Band III																								
Direction Gain	5.01dBi for UNII Band I 5.01dBi for UNII Band III																								
Power supply	DC 12V from Adapter																								
	<input checked="" type="checkbox"/> Adapter: Model: GSCU1000S012V15G AC Input: 100-240V~ 50/60Hz DC Output: 12V 1.0A																								

Note: for more details, please refer to the User's manual of the EUT.

3 SUMMARY OF TEST RESULT

FCC Part Clause	Test Parameter	Verdict	Remark
15.407 (a) 15.407 (e)	99% , 6dB and 26dB Bandwidth	PASS	
15.407 (a)	Maximum Conducted Output Power	PASS	
15.407 (a)	Peak Power Spectral Density	PASS	
15.407 (b)	Radiated Spurious Emission	PASS	
15.407(g)	Frequency Stability	PASS	
15.407 (b)(6) 15.207	Power Line Conducted Emission	PASS	
15.407(a) 15.203	Antenna Application	PASS	
NOTE1: N/A (Not Applicable) NOTE2: According to FCC OET KDB 789003 D2 General UNII Test Procedures New Rules v01r02, In addition, the radiated test is also performed to ensure the emissions emanating from the device cabinet also comply with the applicable limits.			

RELATED SUBMITTAL(S) / GRANT(S):

This submittal(s) (test report) is intended for FCC ID: 2AONY-DE3146 filing to comply with Section 15.247 of the FCC Part 15, Subpart E Rules.

4 TEST METHODOLOGY

4.1 GENERAL DESCRIPTION OF APPLIED STANDARDS

According to its specifications, the EUT must comply with the requirements of the following standards:

FCC 47 CFR Part 2, Subpart J

FCC 47 CFR Part 15, Subpart E

FCC KDB 789033 D2 General UNII Test Procedures New Rules v01r04

FCC KDB 662911 D01 Multiple Transmitter Output v02r01

FCC KDB 662911 D02 MIMO With Cross Polarized Antenna V01

4.2 MEASUREMENT EQUIPMENT USED

4.2.1 Conducted Emission Test Equipment

EQUIPMENT TYPE	MFR	MODEL NUMBER	SERIAL NUMBER	LASTCAL.	DUE CAL.
Test Receiver	Rohde & Schwarz	ESCI	26115-010-0027	May 20, 2017	May 19, 2018
L.I.S.N.	Rohde & Schwarz	ENV216	101161	May 20, 2017	May 19, 2018
50Ω Coaxial Switch	Anritsu	MP59B	6100175589	May 21, 2017	May 20, 2018
Voltage Probe	Rohde & Schwarz	ESH2-Z3	100122	May 21, 2017	May 20, 2018
Pulse Limiter	Rohde & Schwarz	ESH3-Z2	100006	May 20, 2017	May 19, 2018
I.S.N	Teseq GmbH	ISN T800	30327	May 21, 2017	May 20, 2018

4.2.2 Radiated Emission Test Equipment

EQUIPMENT TYPE	MFR	MODEL NUMBER	SERIAL NUMBER	LAST CAL.	DUE CAL.
EMI Test Receiver	Rohde & Schwarz	ESU	1302.6005.26	May 21, 2017	May 20, 2018
Pre-Amplifier	HP	8447F	2944A07999	May 20, 2017	May 19, 2018
Bilog Antenna	Schwarzbeck	VULB9163	142	May 20, 2017	May 19, 2018
Loop Antenna	ARA	PLA-1030/B	1029	May 20, 2017	May 19, 2018
Horn Antenna	Schwarzbeck	BBHA 9170	BBHA9170399	May 21, 2017	May 20, 2018
Horn Antenna	Schwarzbeck	BBHA 9120	D143	May 20, 2017	May 19, 2018
Cable	Schwarzbeck	AK9513	ACRX1	May 21, 2017	May 20, 2018
Cable	Rosenberger	N/A	FP2RX2	May 21, 2017	May 20, 2018
Cable	Schwarzbeck	AK9513	CRPX1	May 21, 2017	May 20, 2018
Cable	Schwarzbeck	AK9513	CRRX2	May 21, 2017	May 20, 2018

4.2.3 Radio Frequency Test Equipment

EQUIPMENT TYPE	MFR	MODEL NUMBER	SERIAL NUMBER	LASTCAL.	DUE CAL.
Spectrum Analyzer	Agilent	E4407B	88156318	May 21, 2017	May 20, 2018
Signal Analyzer	Agilent	N9010A	My53470879	May 21, 2017	May 20, 2018
Power meter	Anritsu	ML2495A	0824006	May 21, 2017	May 20, 2018
Power sensor	Anritsu	MA2411B	0738172	May 21, 2017	May 20, 2018

Remark: Each piece of equipment is scheduled for calibration once a year.

4.3 DESCRIPTION OF TEST MODES

The EUT has been tested under its typical operating condition.

The EUT configuration for testing is installed on RF field strength measurement to meet the Commissions requirement and operating in a manner which intends to maximize its emission characteristics in a continuous normal application.

The Transmitter was operated in the normal operating mode. The TX frequency was fixed which was for the purpose of the measurements.

Test of channel included the lowest and middle and highest frequency to perform the test, then record on this report.

Those data rates (802.11a: 6 Mbps; 802.11n (HT20): MCS0; 802.11n (HT20): MCS7; 802.11n (HT40): MCS0; 802.11n (HT40): MCS7; 802.11ac (HT20): MCS0; 802.11ac (HT20): MCS7; 802.11ac (HT40): MCS0; 802.11ac (HT40): MCS9; 802.11ac (HT80): MCS0; 802.11ac (HT80): MCS9;) were used for all test.

Pre-defined engineering program for regulatory testing used to control the EUT for staying in continuous transmitting and receiving mode is programmed.

Wifi 5G with UNII Band I

Frequency and Channel list for 802.11a/n(HT20)/ac(VHT20):

Channel	Frequency (MHz)	Channel	Frequency (MHz)	Channel	Frequency (MHz)
36	5180	44	5220		
40	5200	48	5240		

Frequency and Channel list for 802.11n(HT40)/ac(VHT40):

Channel	Frequency (MHz)	Channel	Frequency (MHz)	Channel	Frequency (MHz)
38	5190				
46	5230				

Frequency and Channel list for 802.11ac(VHT80):

Channel	Frequency (MHz)	Channel	Frequency (MHz)	Channel	Frequency (MHz)
42	5210				

Test Frequency and Channel for 802.11a/n(HT20)/ac(VHT20):

Lowest Frequency		Middle Frequency		Highest Frequency	
Channel	Frequency (MHz)	Channel	Frequency (MHz)	Channel	Frequency (MHz)
36	5180	40	5200	48	5240

Test Frequency and channel for 802.11n(VHT40)/ac(VHT40):

Lowest Frequency		Middle Frequency		Highest Frequency	
Channel	Frequency (MHz)	Channel	Frequency (MHz)	Channel	Frequency (MHz)
38	5190	N/A	N/A	46	5230

Test Frequency and channel for 802.11ac(HT80):

Lowest Frequency		Middle Frequency		Highest Frequency	
Channel	Frequency (MHz)	Channel	Frequency (MHz)	Channel	Frequency (MHz)
42	5210	N/A	N/A	N/A	N/A

Wifi 5G with UNII Band III

Frequency and Channel list for 802.11a/n(HT20)/ac(VHT20):

Channel	Frequency (MHz)	Channel	Frequency (MHz)	Channel	Frequency (MHz)
149	5745	157	5785	165	5825
153	5765	161	5805		

Frequency and Channel list for 802.11n(HT40)/ac(VHT40):

Channel	Frequency (MHz)	Channel	Frequency (MHz)	Channel	Frequency (MHz)
151	5755				
159	5795				

Frequency and Channel list for 802.11ac(VHT80):

Channel	Frequency (MHz)	Channel	Frequency (MHz)	Channel	Frequency (MHz)
155	5775				

Test Frequency and Channel for 802.11a/n(HT20)/ac(VHT20):

Lowest Frequency		Middle Frequency		Highest Frequency	
Channel	Frequency (MHz)	Channel	Frequency (MHz)	Channel	Frequency (MHz)
149	5745	157	5785	165	5825

Test Frequency and channel for 802.11n(HT40)/ac(VHT40):

Lowest Frequency		Middle Frequency		Highest Frequency	
Channel	Frequency (MHz)	Channel	Frequency (MHz)	Channel	Frequency (MHz)
151	5755	N/A	N/A	159	5795

Test Frequency and channel for 802.11ac(VHT80):

Lowest Frequency		Middle Frequency		Highest Frequency	
Channel	Frequency (MHz)	Channel	Frequency (MHz)	Channel	Frequency (MHz)
155	5775				

5 FACILITIES AND ACCREDITATIONS

5.1 FACILITIES

All measurement facilities used to collect the measurement data are located at

Bldg 69, Majialong Industry Zone District, Nanshan District, Shenzhen, China

The sites are constructed in conformance with the requirements of ANSI C63.7, ANSI C63.10 and CISPR Publication 22.

5.2 LABORATORY ACCREDITATIONS AND LISTINGS

Site Description

EMC Lab.

: Accredited by CNAS, 2016.10.24
The certificate is valid until 2022.10.28
The Laboratory has been assessed and proved to be in compliance with
CNAS-CL01:2006 (identical to ISO/IEC 17025:2005)
The Certificate Registration Number is L2291.

Accredited by TUV Rheinland Shenzhen 2016.5.19

The Laboratory has been assessed according to the requirements
ISO/IEC 17025.

Accredited by FCC, August 03, 2017

Designation Number: CN1204

Test Firm Registration Number: 882943

Accredited by A2LA, July 31, 2017

The Certificate Registration Number is 4321.01.

Accredited by Industry Canada, November 24, 2015

The Certificate Registration Number is 4480A.

Name of Firm

: EMTEK(SHENZHEN) CO., LTD..

Site Location

: Bldg 69, Majialong Industry Zone,
Nanshan District, Shenzhen, Guangdong, China

6 TEST SYSTEM UNCERTAINTY

The following measurement uncertainty levels have been estimated for tests performed on the apparatus:

Parameter	Uncertainty
Radio Frequency	$\pm 1 \times 10^{-5}$
Maximum Peak Output Power Test	$\pm 1.0\text{dB}$
Conducted Emissions Test	$\pm 2.0\text{dB}$
Radiated Emission Test	$\pm 2.0\text{dB}$
Power Density	$\pm 2.0\text{dB}$
Occupied Bandwidth Test	$\pm 1.0\text{dB}$
Band Edge Test	$\pm 3\text{dB}$
All emission, radiated	$\pm 3\text{dB}$
Antenna Port Emission	$\pm 3\text{dB}$
Temperature	$\pm 0.5^\circ\text{C}$
Humidity	$\pm 3\%$

Measurement Uncertainty for a level of Confidence of 95%

7 SETUP OF EQUIPMENT UNDER TEST

7.1 RADIO FREQUENCY TEST SETUP

The WLAN component's antenna ports(s) of the EUT are connected to the measurement instrument per an appropriate attenuator. The EUT is controlled by PC/software to emit the specified signals for the purpose of measurements.

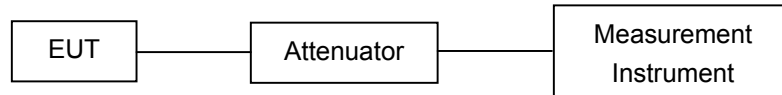

7.2 RADIO FREQUENCY TEST SETUP

The test site semi-anechoic chamber has met the requirement of NSA tolerance 4 dB according to the standards: ANSI C63.10. The test distance is 3m. The setup is according to the requirements in Section 13.1.4.1 of ANSI C63.10-2013 and CAN/CSA-CEI/IEC CISPR 22.

Below 30MHz:

The EUT is placed on a turntable 0.8 meters above the ground in the chamber, 3 meter away from the antenna (loop antenna). The Antenna should be positioned with its plane vertical at the specified distance from the EUT and rotated about its vertical axis for maximum response at each azimuth about the EUT. The center of the loop shall be 1 m above the ground. For certain applications, the loop antenna plane may also need to be positioned horizontally at the specified distance from the EUT.

Above 30MHz:

The EUT is placed on a turntable 0.8 meters above the ground in the chamber, 3 meter away from the antenna. The maximal emission value is acquired by adjusting the antenna height, polarisation and turntable azimuth. Normally, the height range of antenna is 1 m to 4 m, the azimuth range of turntable is 0° to 360°, and the receive antenna has two polarizations Vertical (V) and Horizontal (H).

Above 1GHz:

(Note: the FCC's permission to use 1.5m as an alternative per TCBC Conf call of Dec. 2, 2014.)

The EUT is placed on a turntable 1.5 meters above the ground in the chamber, 3 meter away from the antenna. The maximal emission value is acquired by adjusting the antenna height, polarisation and turntable azimuth. Normally, the height range of antenna is 1 m to 4 m, the azimuth range of turntable is 0° to 360°, and the receive antenna has two polarizations Vertical (V) and Horizontal (H).

(a) Radiated Emission Test Set-Up, Frequency Below 30MHz

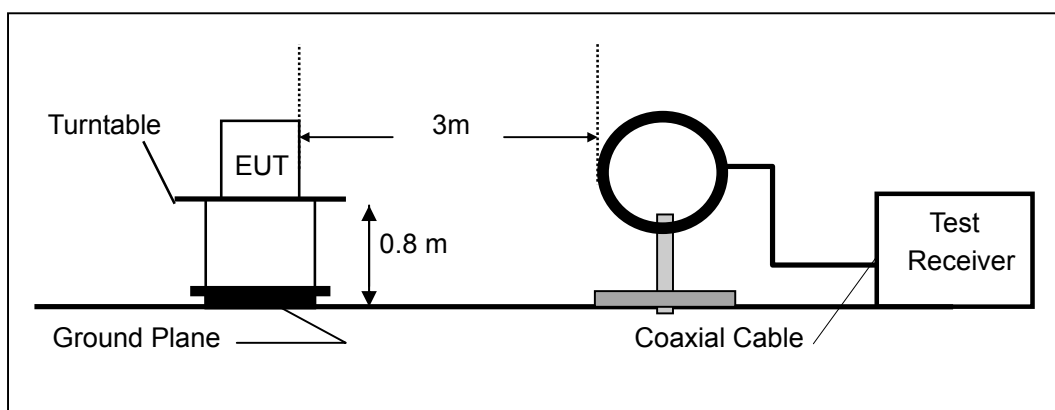

(b) Radiated Emission Test Set-Up, Frequency Below 1000MHz

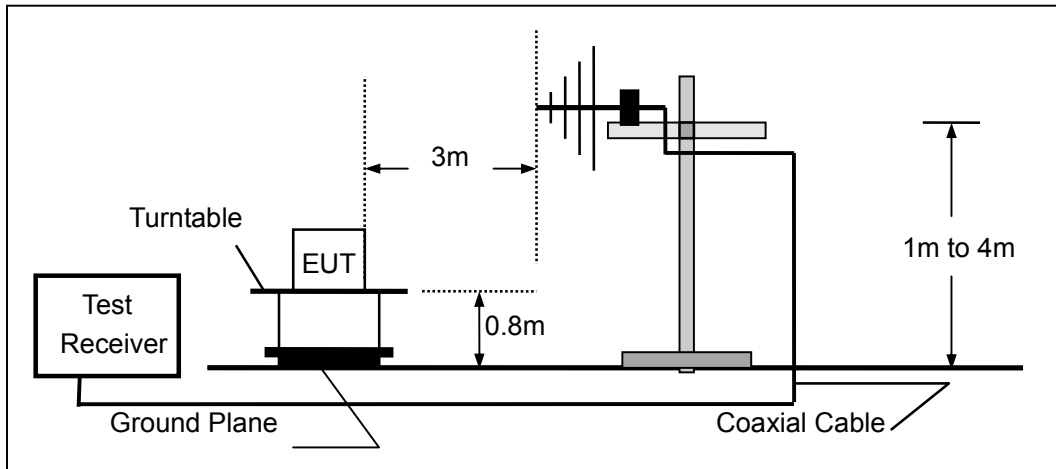

(c) Radiated Emission Test Set-Up, Frequency above 1000MHz

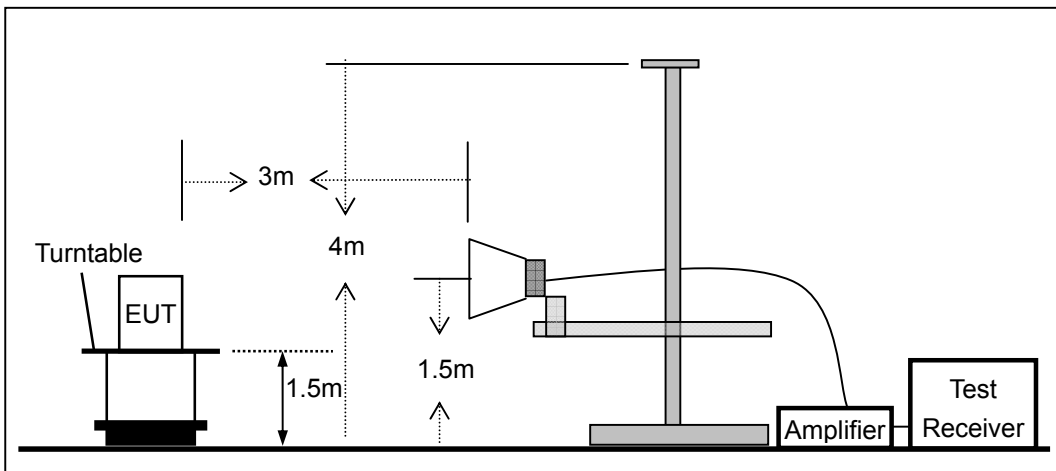

7.3 CONDUCTED EMISSION TEST SETUP

The mains cable of the EUT (maybe per AC/DC Adapter) must be connected to LISN. The LISN shall be placed 0.8 m from the boundary of EUT and bonded to a ground reference plane for LISN mounted on top of the ground reference plane. This distance is between the closest points of the LISN and the EUT. All other units of the EUT and associated equipment shall be at least 0.8m from the LISN.

Ground connections, where required for safety purposes, shall be connected to the reference ground point of the LISN and, where not otherwise provided or specified by the manufacturer, shall be of same length as the mains cable and run parallel to the mains connection at a separation distance of not more than 0.1 m.

According to the requirements in Section 13.1.4.1 of ANSI C63.10-2013 Conducted emissions from the EUT measured in the frequency range between 0.15 MHz and 30 MHz using CISPR Quasi-Peak and average detector mode.

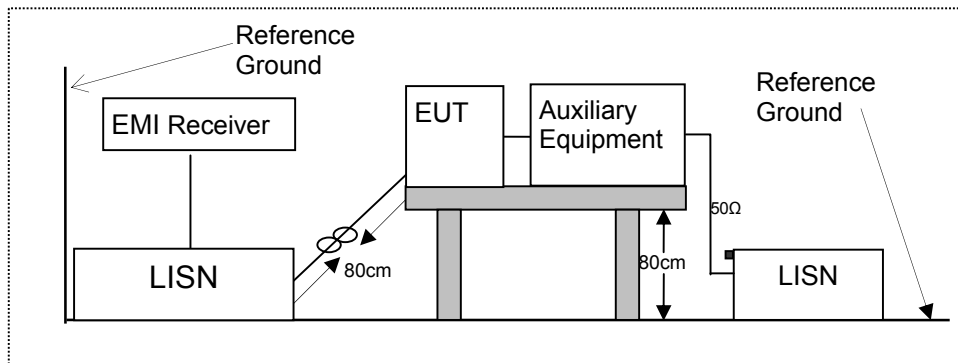

7.4 BLOCK DIAGRAM CONFIGURATION OF TEST SYSTEM

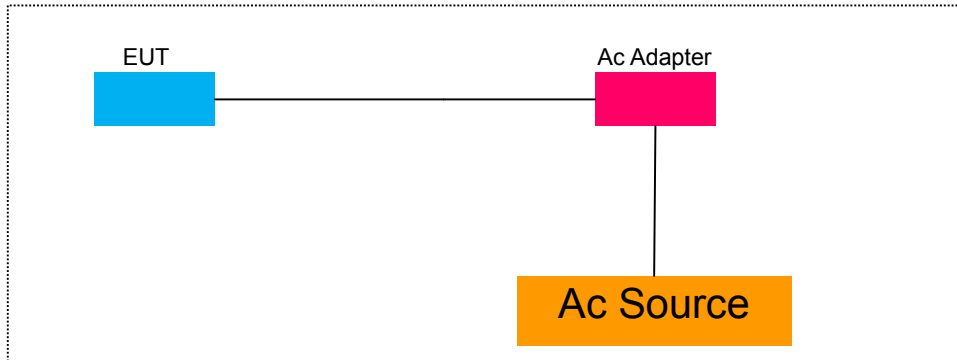

7.5 SUPPORT EQUIPMENT

Item	Equipment	Mfr/Brand	Model/Type No.	FCC ID	Series No.	Note
N/A	N/A	N/A	N/A	N/A	N/A	N/A

Notes:

1. All the equipment/cables were placed in the worst-case configuration to maximize the emission during the test.
2. Grounding was established in accordance with the manufacturer's requirements and conditions for the intended use.

8 TEST REQUIREMENTS

8.1 BANDWIDTH MEASUREMENT

8.1.1 Applicable Standard

According to FCC Part 15.407(a)(1) for UNII Band I
According to FCC Part 15.407(a)(2) for UNII Band II-A and UNII Band II-C
According to FCC Part 15.407(a)(3) for UNII Band III
According to FCC Part 15.407(e) for UNII Band III
According to 789033 D02 Section II(C)
According to 789033 D02 Section II(D)

8.1.2 Conformance Limit

No limit requirement.

The minimum 6 dB emission bandwidth of at least 500 KHz for the UNII Band III.

8.1.3 Test Configuration

Test according to clause 6.1 radio frequency test setup

8.1.4 Test Procedure

Connect the antenna port(s) to the spectrum analyzer input. Using the spectrum analyzer Channel Bandwidth mode, configure the spectrum analyzer as shown below

■ The following procedure shall be used for measuring (26 dB) power bandwidth:

Center Frequency: test Frequency

Set RBW = approximately 1% of the emission bandwidth.

Set the VBW > RBW.

Detector = Peak.

Trace mode = max hold.

X dB Bandwidth: 26 dB

Measure the maximum width of the emission that is 26 dB down from the maximum of the emission.

Compare this with the RBW setting of the analyzer. Readjust RBW and repeat measurement as needed until the RBW/EBW ratio is approximately 1%.

■ Minimum Emission Bandwidth for the UNII Band III

Center Frequency: test Frequency

Set RBW = 100 kHz

Set VBW $\geq 3 \cdot$ RBW

Detector = Peak

Trace mode = max hold

Sweep = auto couple

X dB Bandwidth: 6 dB

Note: The automatic bandwidth measurement capability of a spectrum analyzer or EMI receiver may be employed if it implements the functionality described above.

■ The following procedure shall be used for measuring (99 %) power bandwidth:

Set center frequency to the nominal EUT channel center frequency.

Set span = 1.5 times to 5.0 times the OBW.

Set RBW = 1 % to 5 % of the OBW

Set VBW $\geq 3 \cdot$ RBW

Video averaging is not permitted. Where practical, a sample detection and single sweep mode shall be used. Otherwise, peak detection and max hold mode (until the trace stabilizes) shall be used.

Use the 99 % power bandwidth function of the instrument (if available).

If the instrument does not have a 99 % power bandwidth function, the trace data points are recovered and directly summed in power units. The recovered amplitude data points, beginning at the lowest frequency, are placed in a running sum until 0.5 % of the total is reached; that frequency is recorded as the lower frequency. The process is repeated until 99.5 % of the total is reached; that frequency is recorded as the upper frequency. The 99% occupied bandwidth is the difference between these two frequencies.

8.1.5 Test Results

☒ 802.11a mode								
Temperature : 28°C			Test Date : July 07, 2017					
Humidity : 65 %			Test By: King Kong					
Band	Channel Number	Channel Freq. (MHz)	26dB EBW(MHz)		99% OBW(MHz)		Limit (MHz)	Verdict
			Ant0	Ant1	Ant0	Ant1		
UNII Band I	CH36	5180	21.36	21.35	16.72	16.75	N/A	N/A
	CH40	5200	21.38	21.34	16.73	16.72	N/A	N/A
	CH48	5240	21.33	21.36	16.74	16.73	N/A	N/A
UNII Band III	CH149	5745	21.28	21.28	16.70	16.71	N/A	N/A
	CH157	5785	21.46	21.47	16.74	16.70	N/A	N/A
	CH165	5825	21.37	21.31	16.72	16.70	N/A	N/A
Note: N/A (Not Applicable)								

☒ 802.11n(VHT20) mode								
Temperature : 28°C			Test Date : July 07, 2017					
Humidity : 65 %			Test By: King Kong					
Band	Channel Number	Channel Freq. (MHz)	26dB EBW(MHz)		99% OBW(MHz)		Limit (MHz)	Verdict
			Ant0	Ant1	Ant0	Ant1		
UNII Band I	CH36	5180	21.48	21.38	17.89	17.88	N/A	N/A
	CH40	5200	21.56	21.39	17.85	17.81	N/A	N/A
	CH48	5240	21.75	21.51	17.84	17.86	N/A	N/A
UNII Band III	CH149	5745	21.53	21.57	17.88	17.83	N/A	N/A
	CH157	5785	21.52	21.32	17.86	17.87	N/A	N/A
	CH165	5825	21.50	21.36	17.88	17.85	N/A	N/A
Note: N/A (Not Applicable)								

☒ 802.11ac(VHT20) mode								
Temperature : 28°C			Test Date : July 07, 2017					
Humidity : 65 %			Test By: King Kong					
Band	Channel Number	Channel Freq. (MHz)	26dB EBW(MHz)		99% OBW(MHz)		Limit (MHz)	Verdict
			Ant0	Ant1	Ant0	Ant1		
UNII Band I	CH36	5180	21.71	21.36	17.85	17.90	N/A	N/A
	CH40	5200	21.56	21.57	17.87	17.85	N/A	N/A
	CH48	5240	21.40	21.56	17.85	17.88	N/A	N/A
UNII Band III	CH149	5745	21.66	21.34	17.87	17.85	N/A	N/A
	CH157	5785	21.68	21.75	17.89	17.83	N/A	N/A
	CH165	5825	21.61	21.68	17.87	17.84	N/A	N/A
Note: N/A (Not Applicable)								

Temperature :	28 °C	<input checked="" type="checkbox"/> UNII Band III	Test Date :	July 07, 2017
Humidity :	65 %		Test By:	King Kong

Operation Mode	Channel Number	Channel Freq. (MHz)	6dB EBW (MHz)		Limit (MHz)	Verdict
			Ant0	Ant1		
802.11a	CH149	5745	16.37	16.37	500	PASS
	CH157	5785	16.42	16.39	500	PASS
	CH165	5825	16.38	16.37	500	PASS
802.11n (VHT20)	CH149	5745	17.60	17.61	500	PASS
	CH157	5785	17.60	17.61	500	PASS
	CH165	5825	17.62	17.61	500	PASS
802.11ac (VHT20)	CH149	5745	17.64	17.60	500	PASS
	CH157	5785	17.62	17.60	500	PASS
	CH165	5825	17.60	17.65	500	PASS
802.11n (VHT40)	CH151	5755	36.35	36.39	500	PASS
	CH159	5795	36.41	36.42	500	PASS
802.11ac (VHT40)	CH151	5755	36.38	36.34	500	PASS
	CH159	5795	36.40	36.37	500	PASS
802.11ac (VHT80)	CH155	5775	76.18	76.15	500	PASS
Note: N/A (Not Applicable)						

Emission Bandwidth&99% Occupied Bandwidth	UNII Band I	
Test Model	802.11a	Frequency(MHz)
Ant0		5180

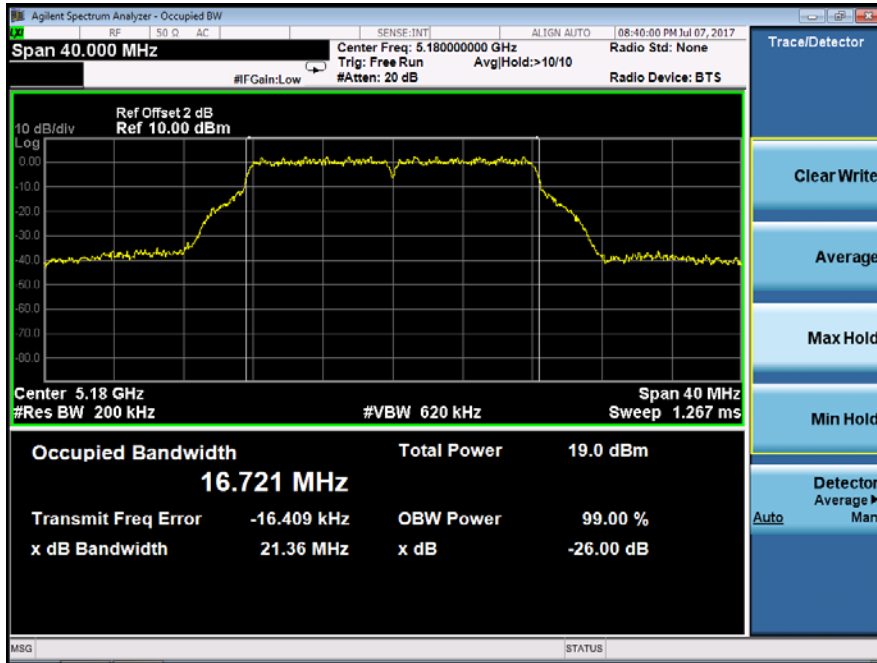

Emission Bandwidth&99% Occupied Bandwidth	UNII Band I	
Test Model	802.11a	Frequency(MHz)
Ant0		5200

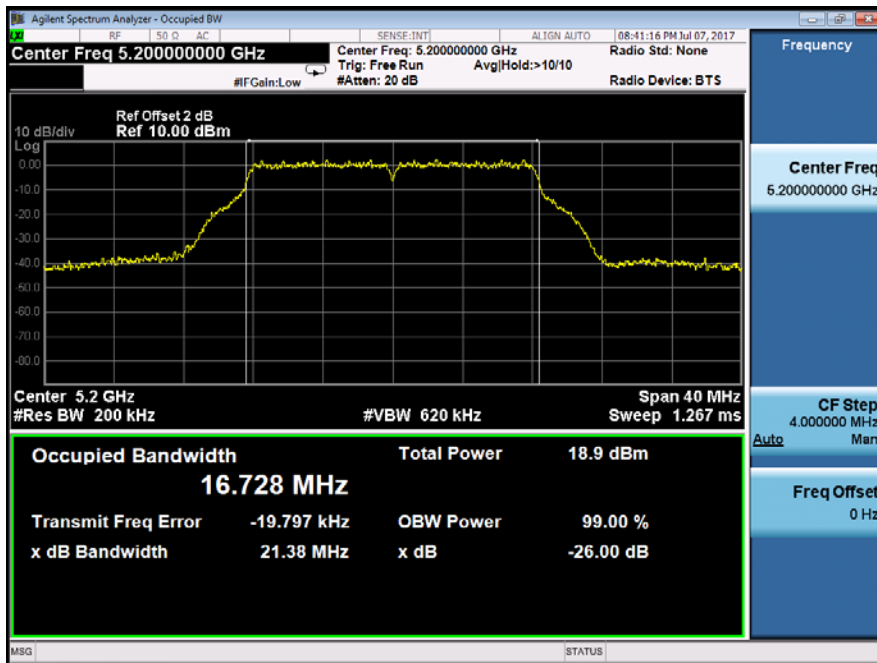

Emission Bandwidth&99% Occupied Bandwidth	UNII Band I	
Test Model	802.11a	Frequency(MHz)
Ant0		5240

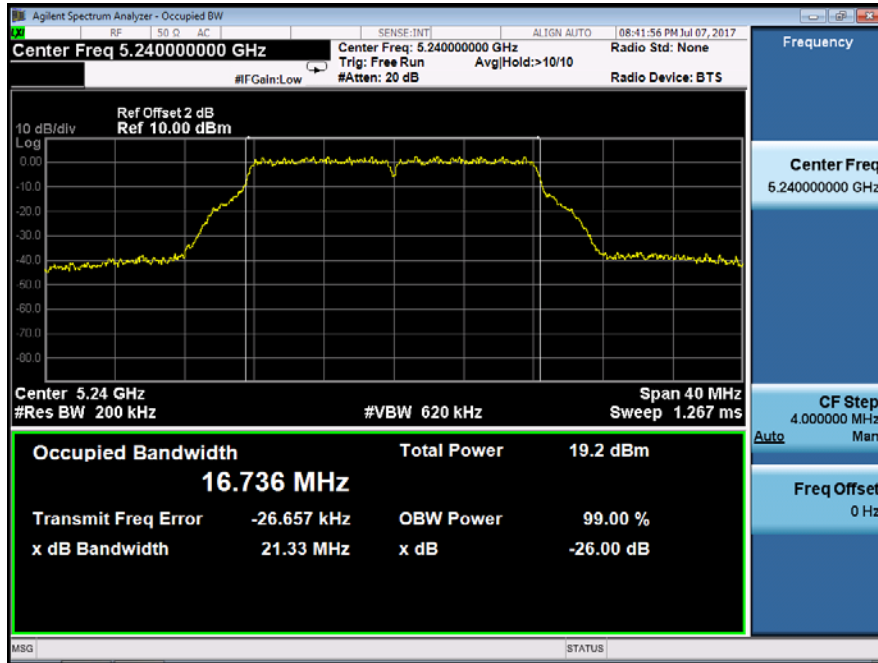

Emission Bandwidth&99% Occupied Bandwidth	UNII Band III	
Test Model	802.11a	Frequency(MHz)
Ant0		5745

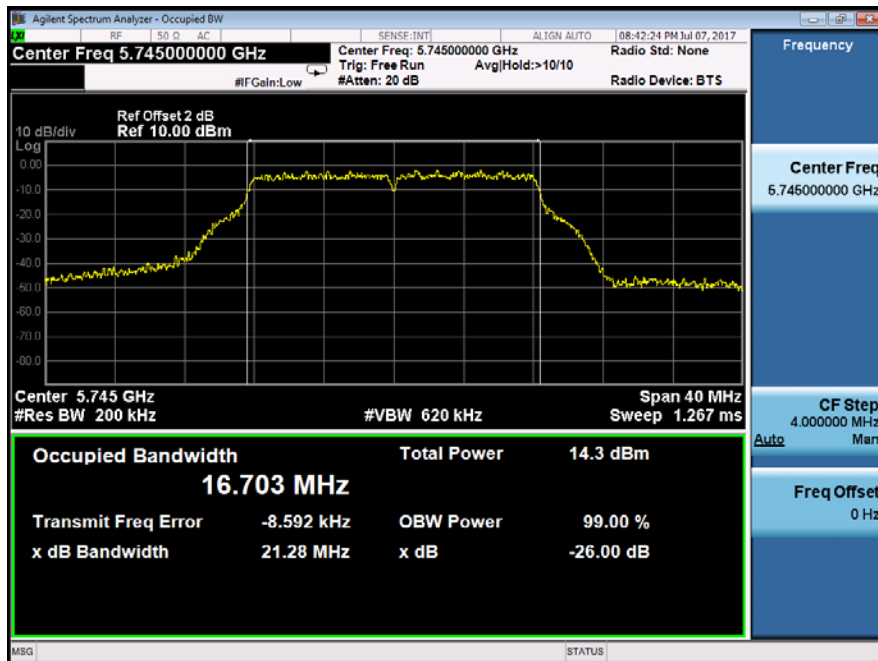

Emission Bandwidth&99% Occupied Bandwidth	UNII Band III
Test Model 802.11a	Frequency(MHz) 5785
Ant0	

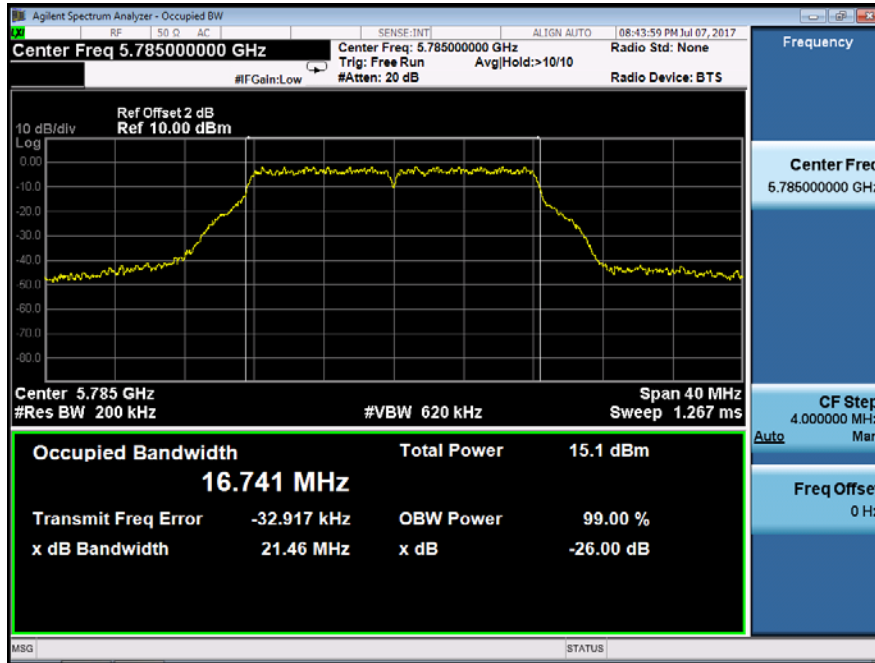

Emission Bandwidth&99% Occupied Bandwidth	UNII Band III
Test Model 802.11a	Frequency(MHz) 5825
Ant0	

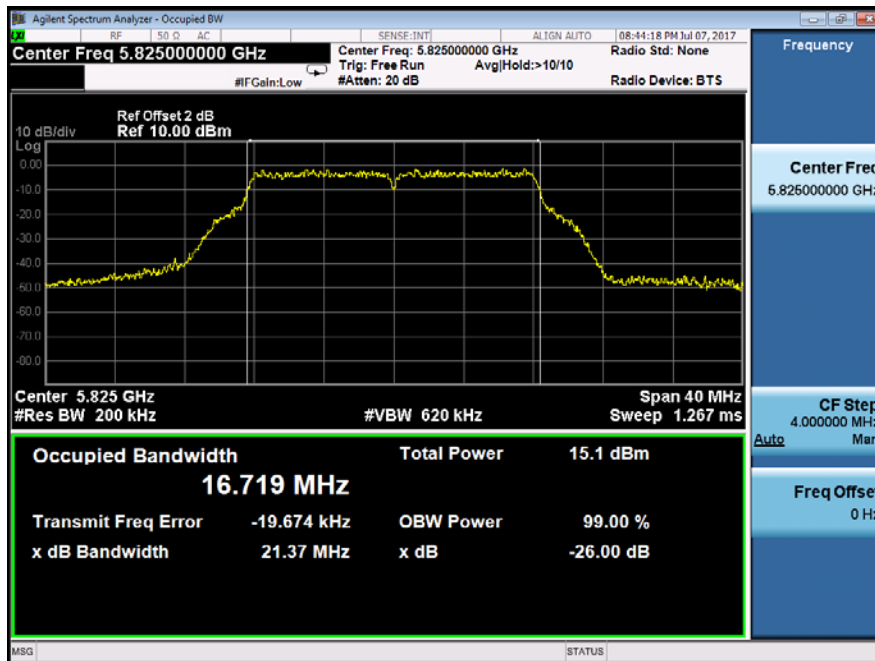

Emission Bandwidth&99% Occupied Bandwidth	UNII Band I	
Test Model	802.11n(VHT20) mode	Frequency(MHz)
Ant0		5180

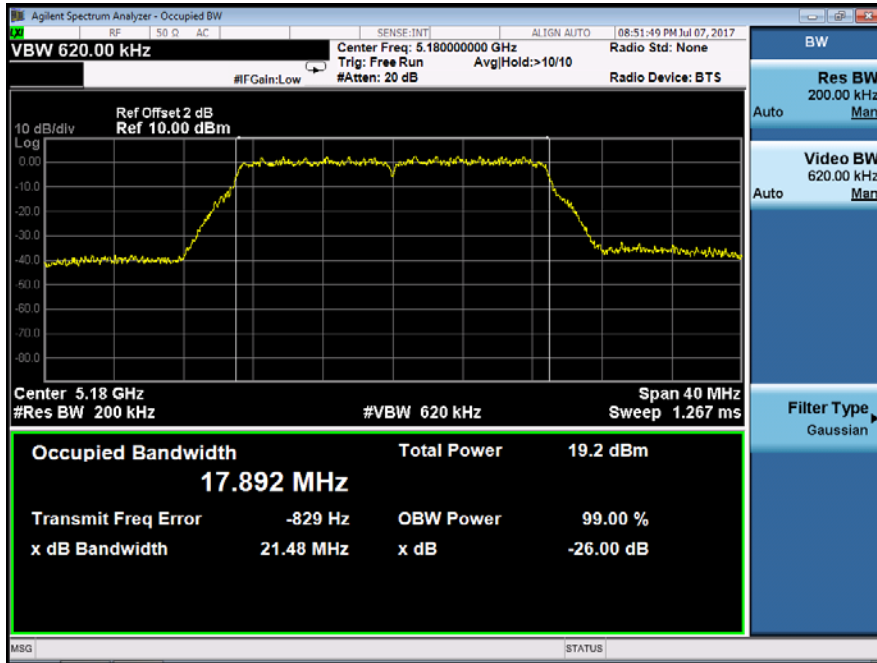

Emission Bandwidth&99% Occupied Bandwidth	UNII Band I	
Test Model	802.11n(VHT20) mode	Frequency(MHz)
Ant0		5200

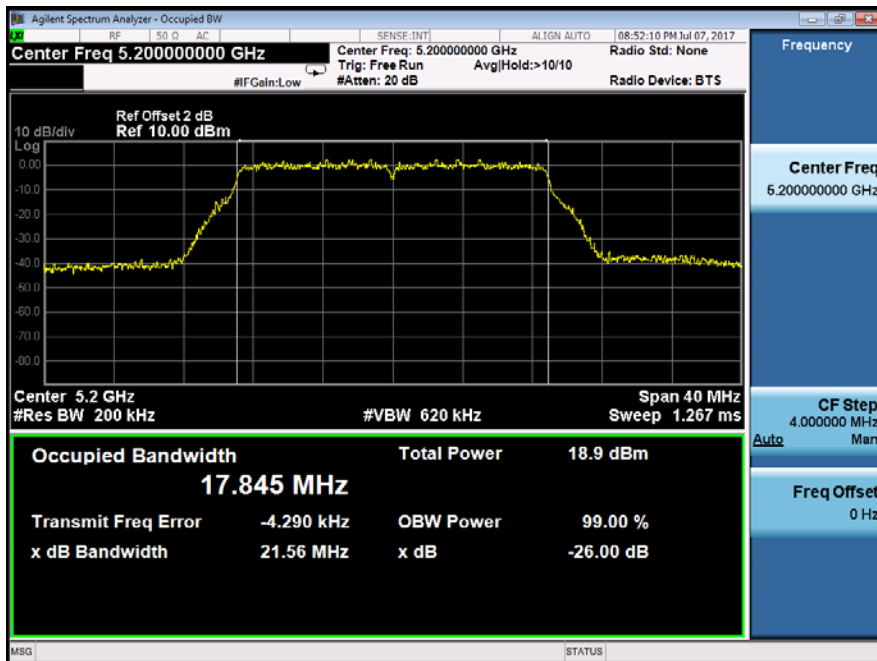

Emission Bandwidth&99% Occupied Bandwidth	UNII Band I	
Test Model	802.11n(VHT20) mode	Frequency(MHz)
Ant0		5240

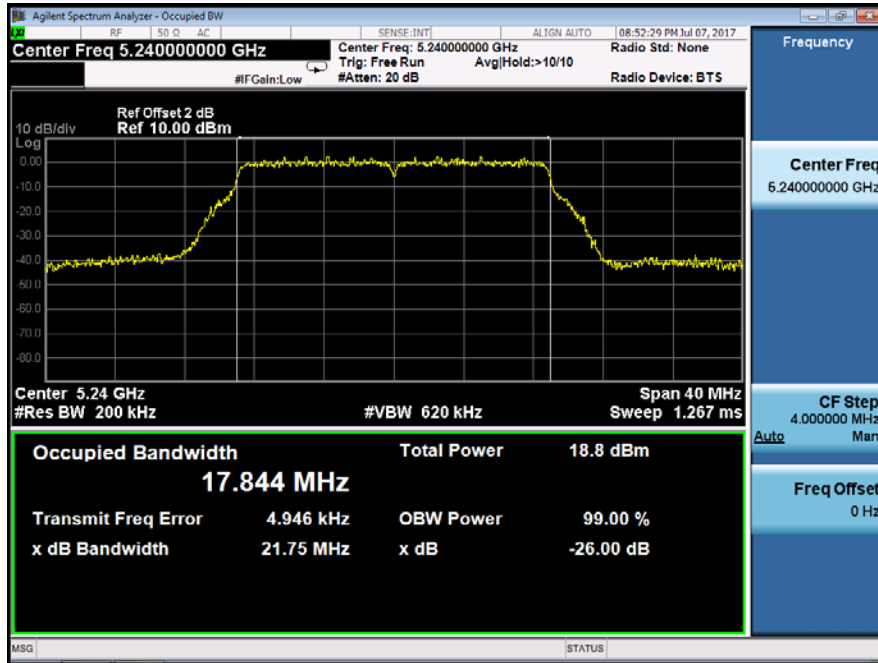

Emission Bandwidth&99% Occupied Bandwidth	UNII Band III	
Test Model	802.11n(VHT20) mode	Frequency(MHz)
Ant0		5745

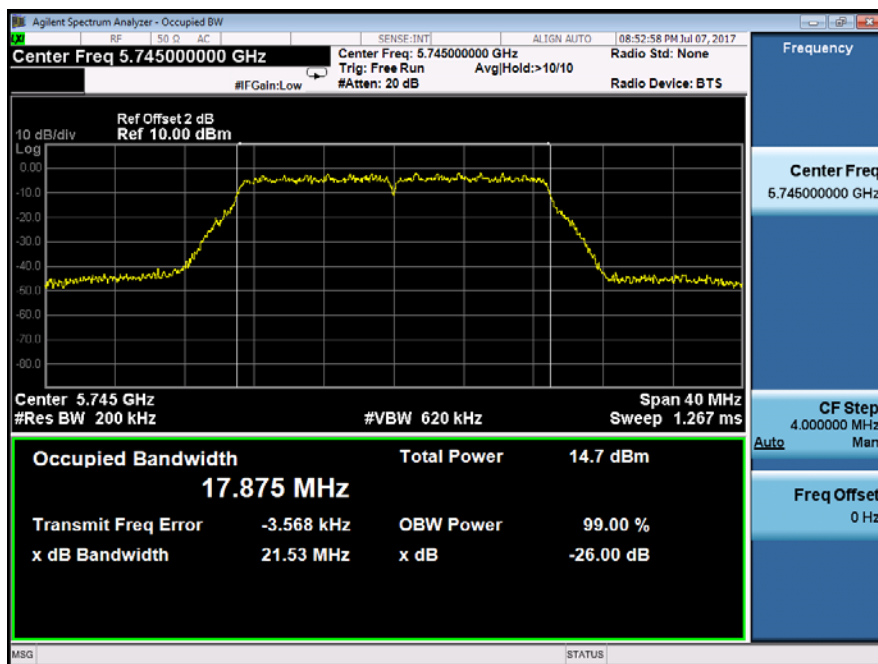

Emission Bandwidth&99% Occupied Bandwidth	UNII Band III	
Test Model	802.11n(VHT20) mode	Frequency(MHz)
Ant0		5785

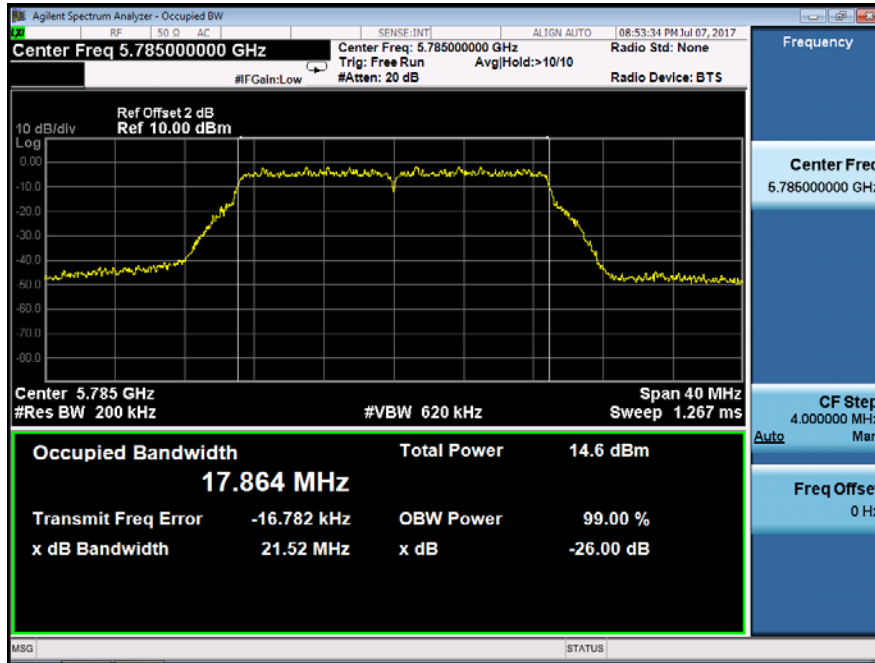

Emission Bandwidth&99% Occupied Bandwidth	UNII Band III	
Test Model	802.11n(VHT20) mode	Frequency(MHz)
Ant0		5825

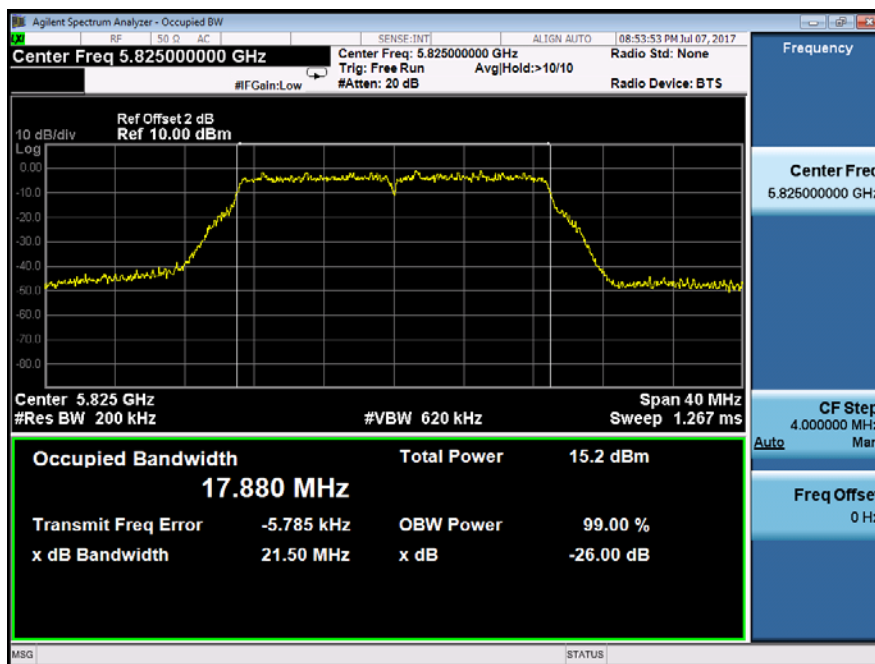

Emission Bandwidth&99% Occupied Bandwidth	UNII Band I
Test Model 802.11ac(VHT20) mode	Frequency(MHz) 5180
Ant0	

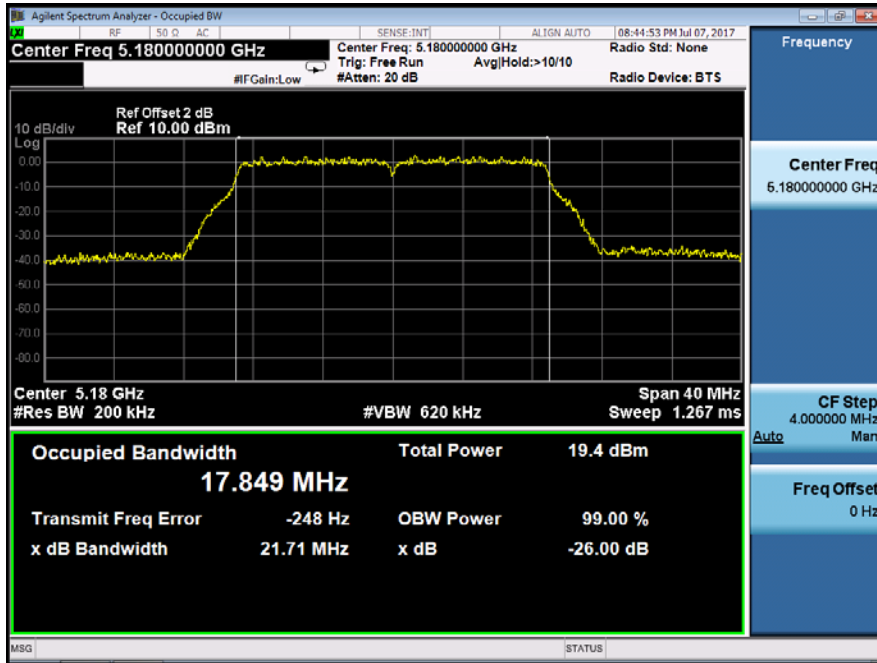

Emission Bandwidth&99% Occupied Bandwidth	UNII Band I
Test Model 802.11ac(VHT20) mode	Frequency(MHz) 5200
Ant0	

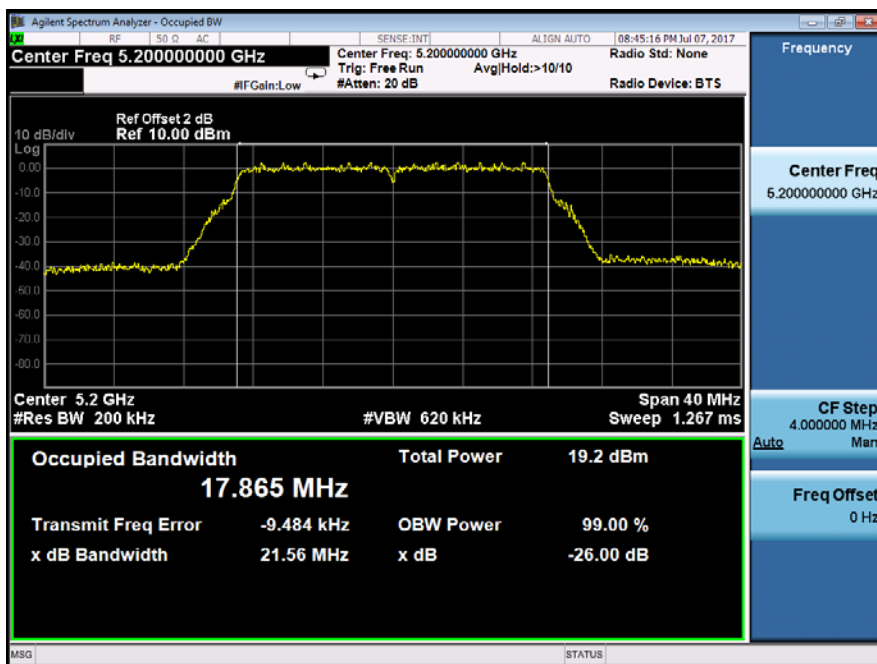

Emission Bandwidth&99% Occupied Bandwidth	UNII Band I
Test Model 802.11ac(VHT20) mode	Frequency(MHz) 5240
Ant0	

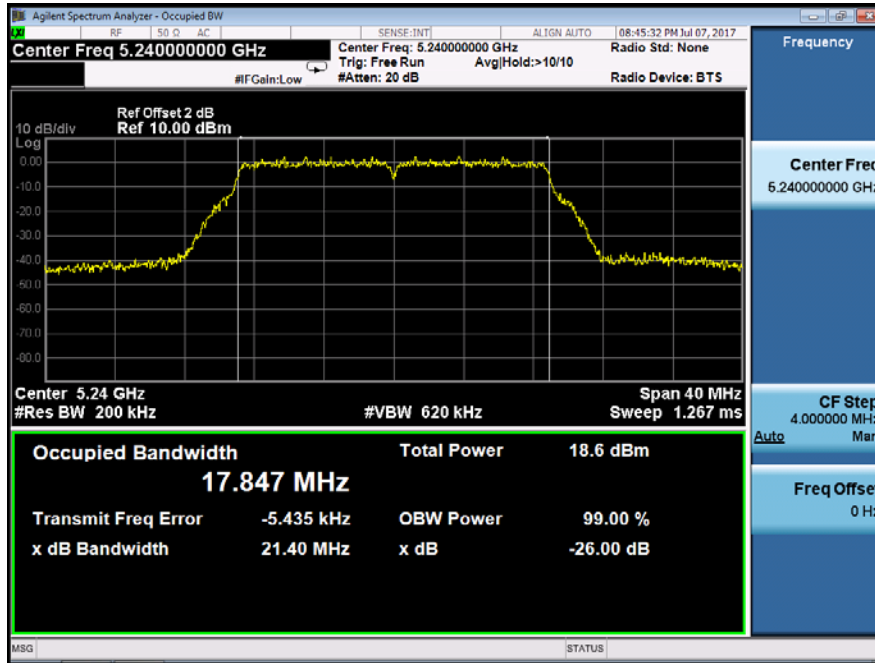

Emission Bandwidth&99% Occupied Bandwidth	UNII Band III
Test Model 802.11ac(VHT20) mode	Frequency(MHz) 5745
Ant0	

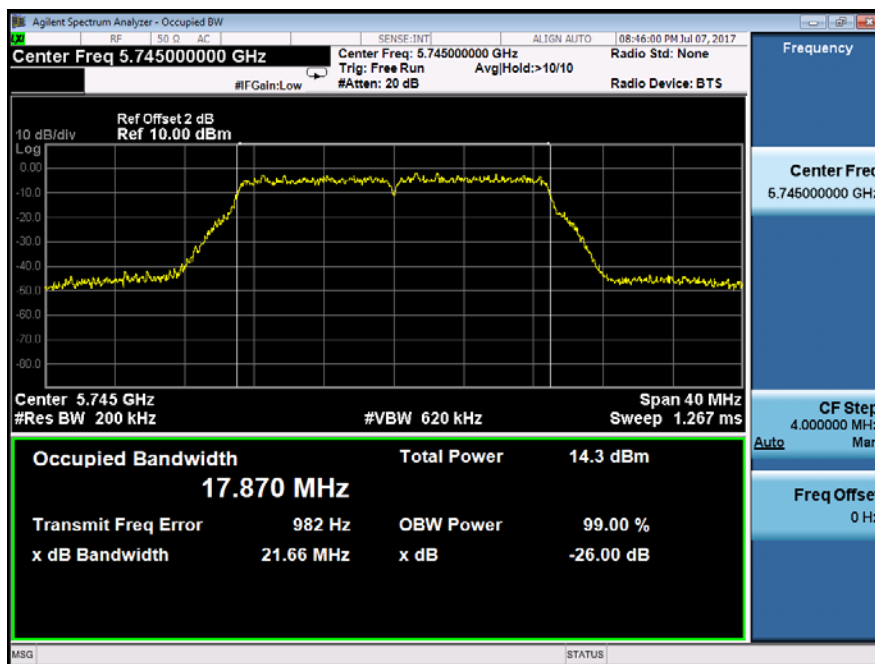

Emission Bandwidth&99% Occupied Bandwidth	UNII Band III	
Test Model	802.11ac(VHT20) mode	Frequency(MHz)
Ant0		5785

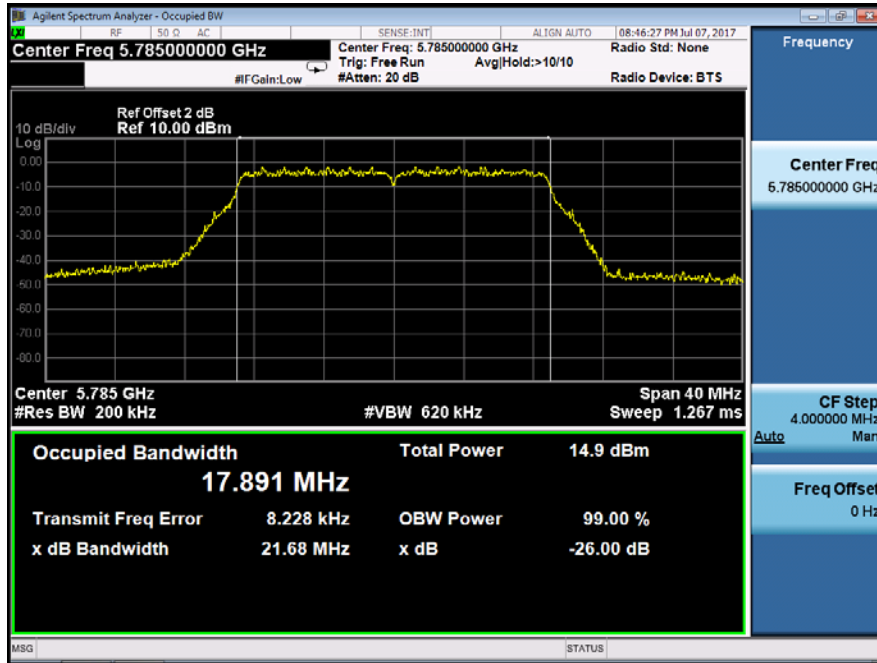

Emission Bandwidth&99% Occupied Bandwidth	UNII Band III	
Test Model	802.11ac(VHT20) mode	Frequency(MHz)
Ant0		5825

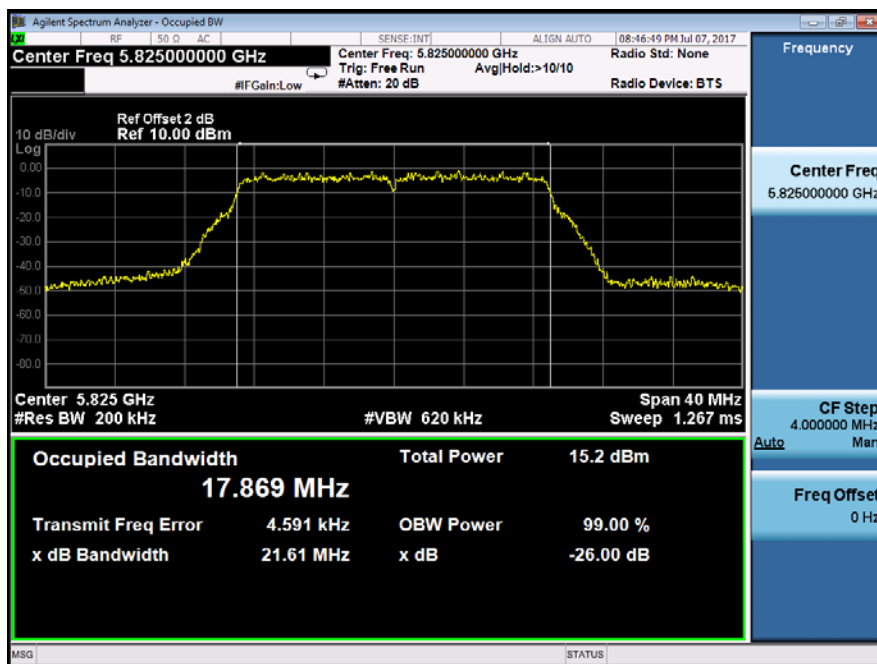

Emission Bandwidth&99% Occupied Bandwidth	UNII Band I	
Test Model	802.11n(VHT40) mode	Frequency(MHz)
Ant0		5190



Emission Bandwidth&99% Occupied Bandwidth	UNII Band I	
Test Model	802.11n(VHT40) mode	Frequency(MHz)
Ant0		5230

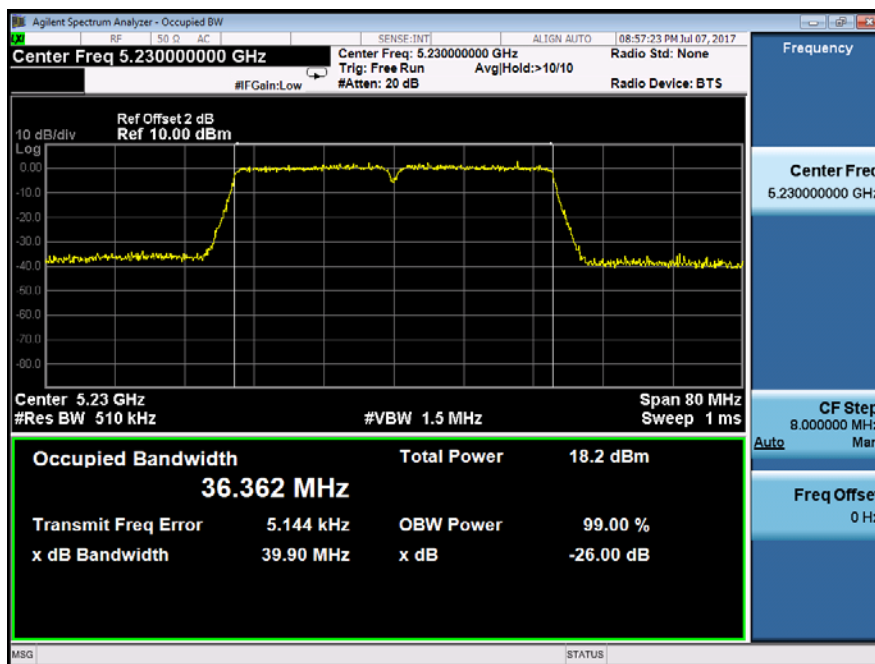

Emission Bandwidth&99% Occupied Bandwidth	UNII Band III	
Test Model	802.11n(VHT40) mode	Frequency(MHz)
Ant0		5755

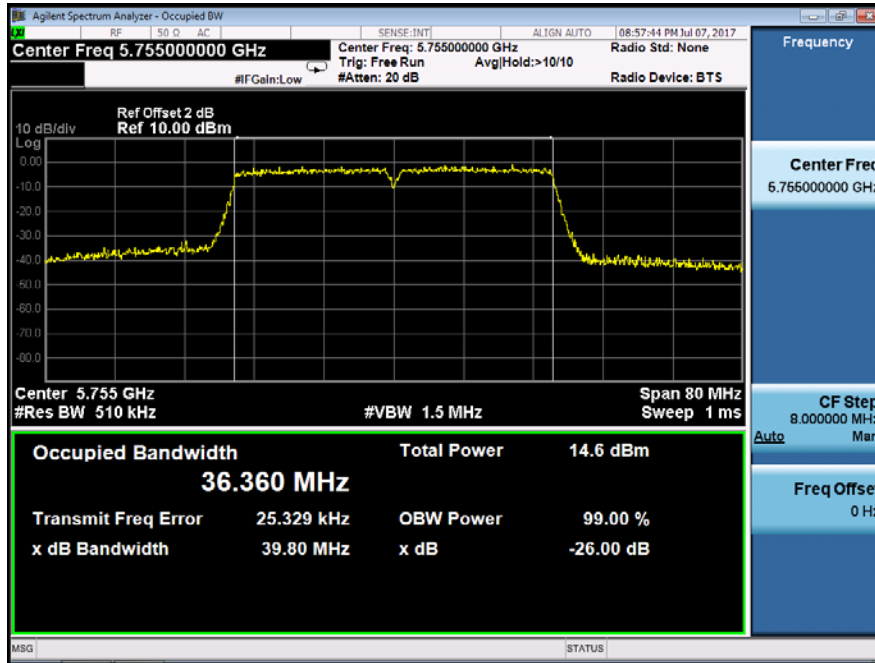

Emission Bandwidth&99% Occupied Bandwidth	UNII Band III	
Test Model	802.11n(VHT40) mode	Frequency(MHz)
Ant0		5795

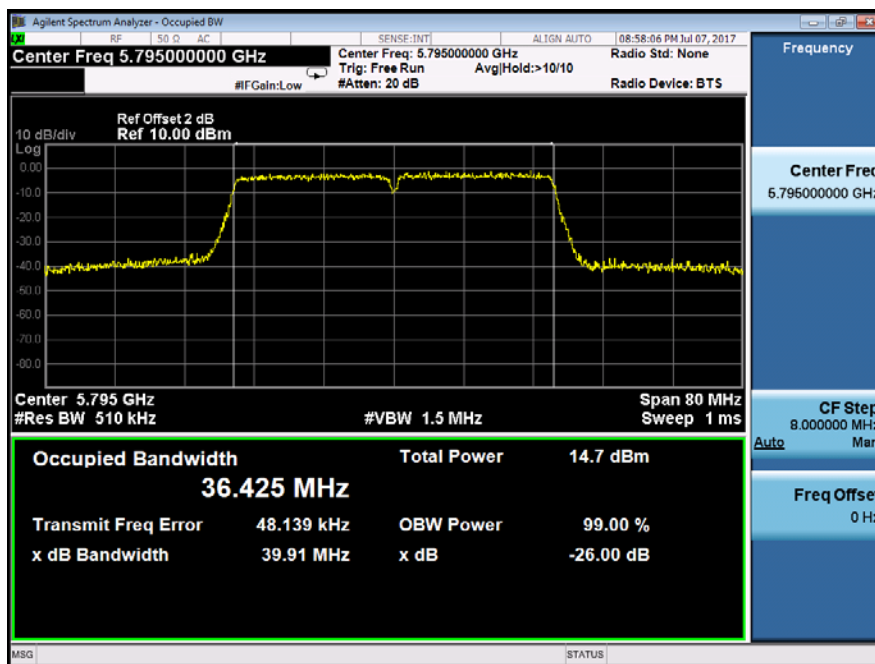

Emission Bandwidth&99% Occupied Bandwidth	UNII Band I
Test Model 802.11ac(VHT40) mode	Frequency(MHz) 5190
Ant0	

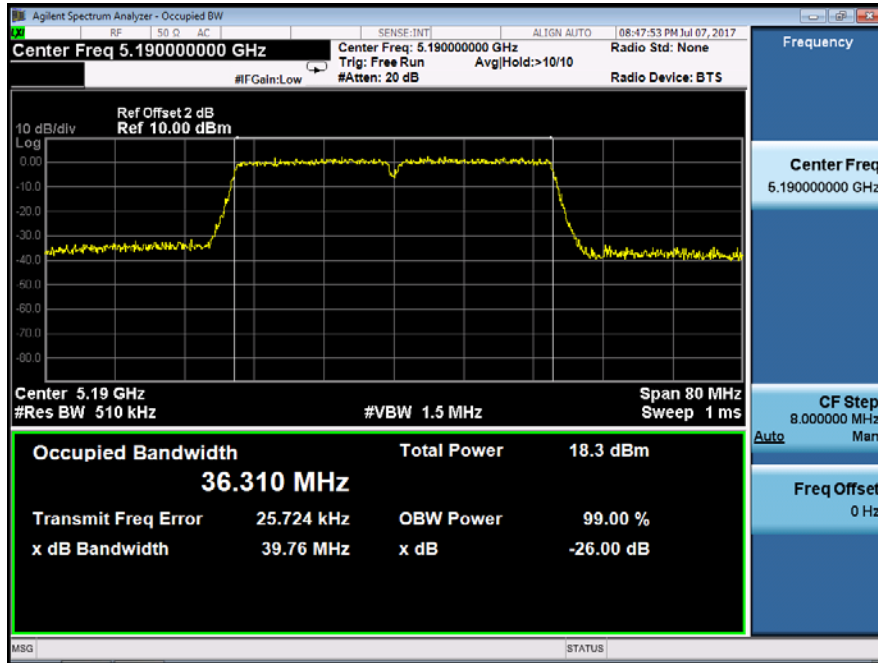

Emission Bandwidth&99% Occupied Bandwidth	UNII Band I
Test Model 802.11ac(VHT40) mode	Frequency(MHz) 5230
Ant0	

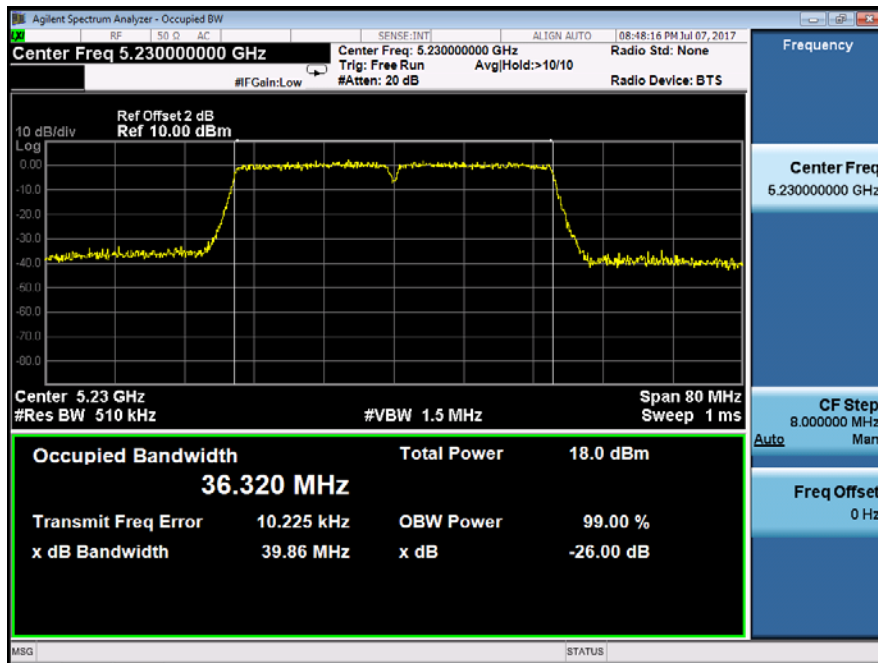

Emission Bandwidth&99% Occupied Bandwidth	UNII Band III	
Test Model	802.11ac(VHT40) mode	Frequency(MHz)
Ant0		5755

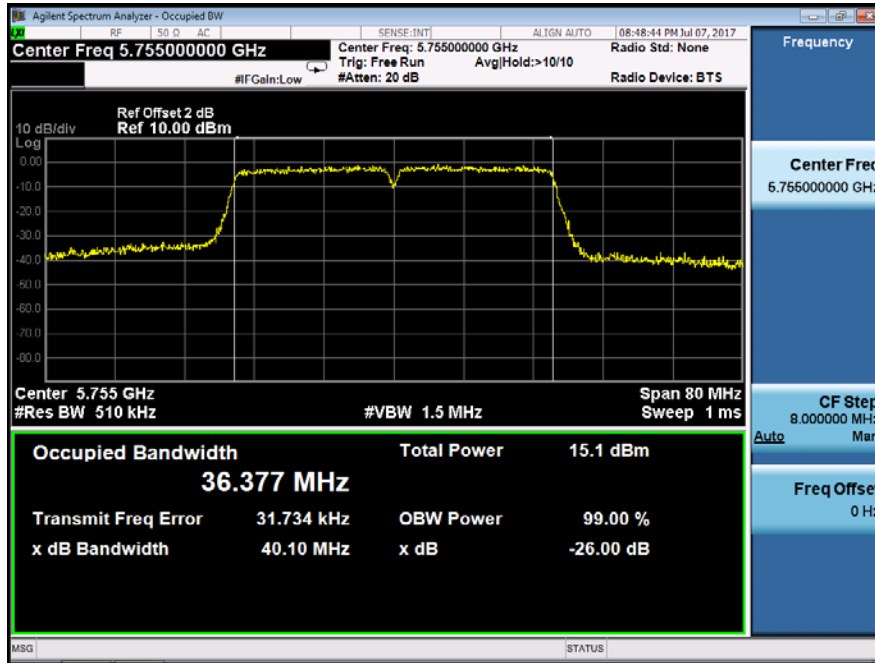

Emission Bandwidth&99% Occupied Bandwidth	UNII Band III	
Test Model	802.11ac(VHT40) mode	Frequency(MHz)
Ant0		5795

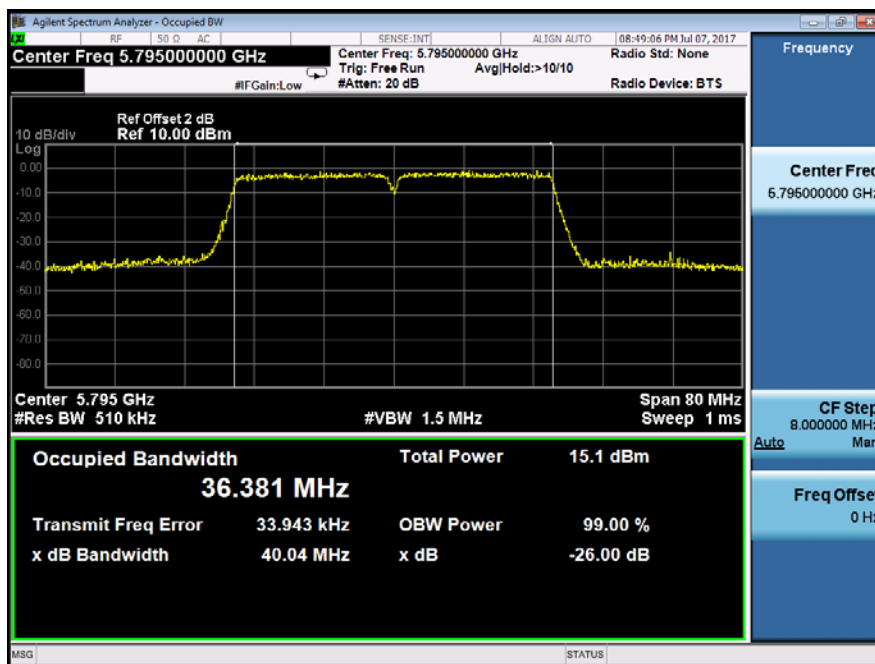

Emission Bandwidth&99% Occupied Bandwidth	UNII Band I
Test Model 802.11ac(VHT80) mode	Frequency(MHz) 5210
Ant0	

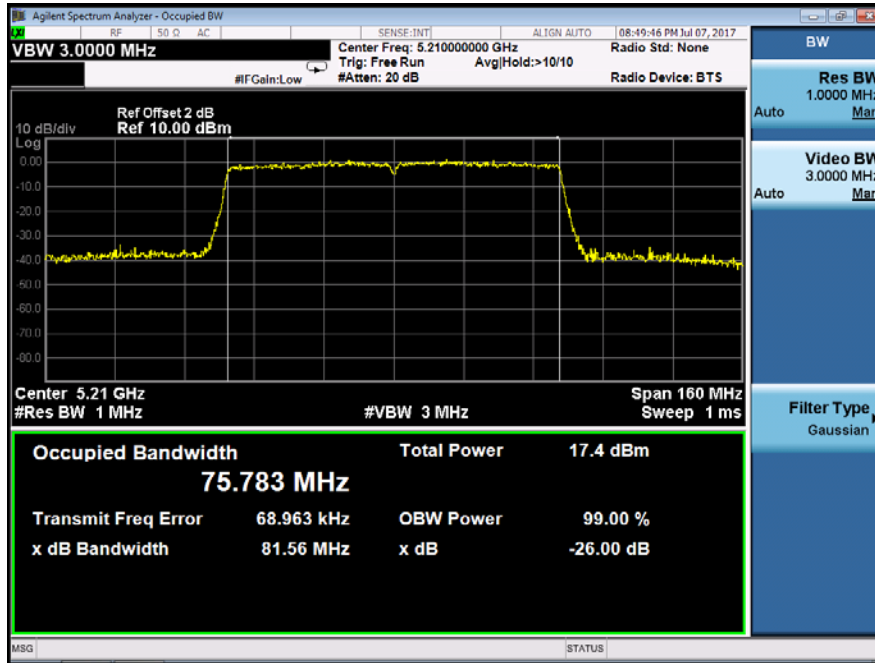

Emission Bandwidth&99% Occupied Bandwidth	UNII Band III
Test Model 802.11ac(VHT80) mode	Frequency(MHz) 5775
Ant0	

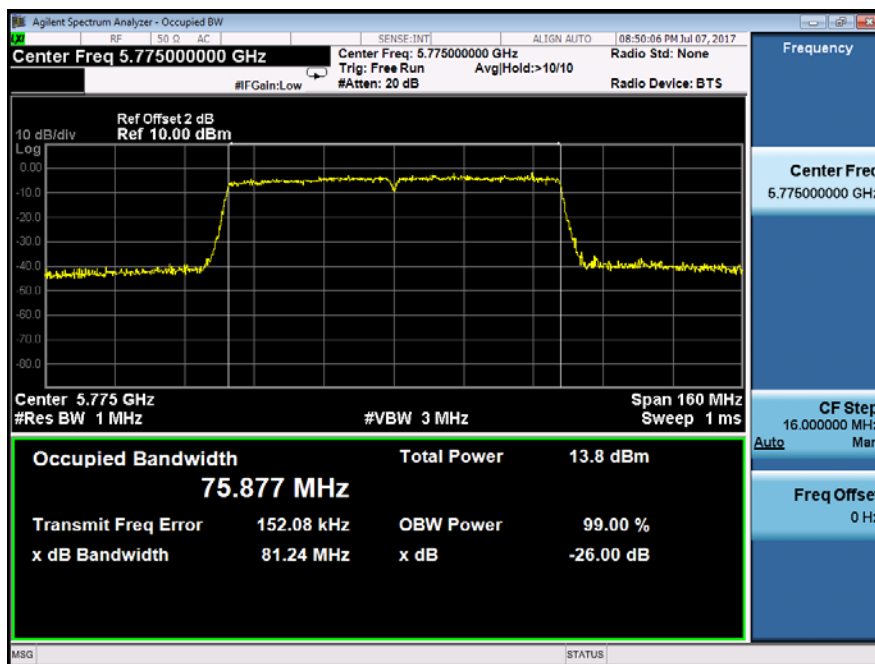

Minimum Emission Bandwidth	UNII Band III	
Test Model	802.11a mode	Frequency(MHz)
Ant0		5745

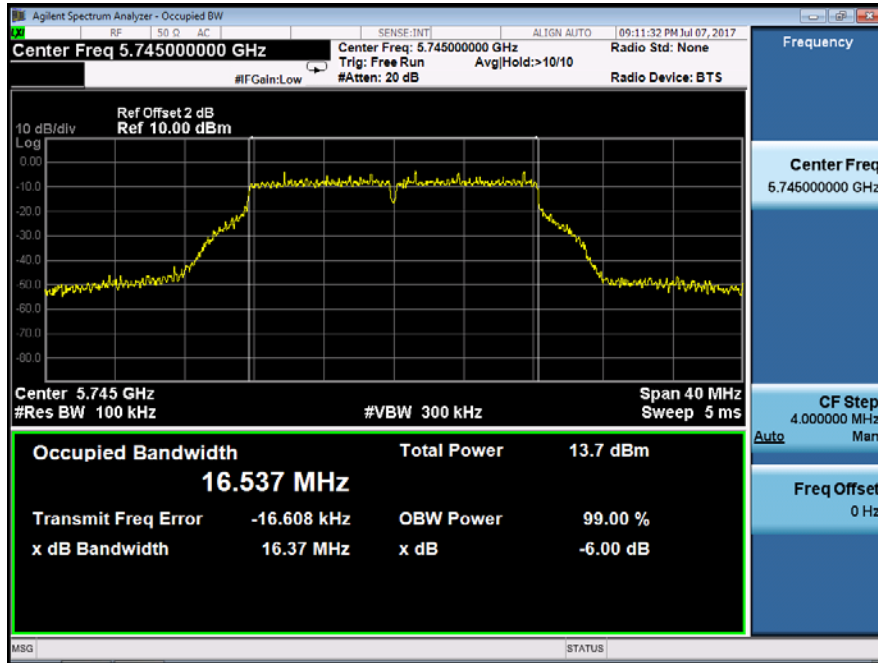

Minimum Emission Bandwidth	UNII Band III	
Test Model	802.11a mode	Frequency(MHz)
Ant0		5785

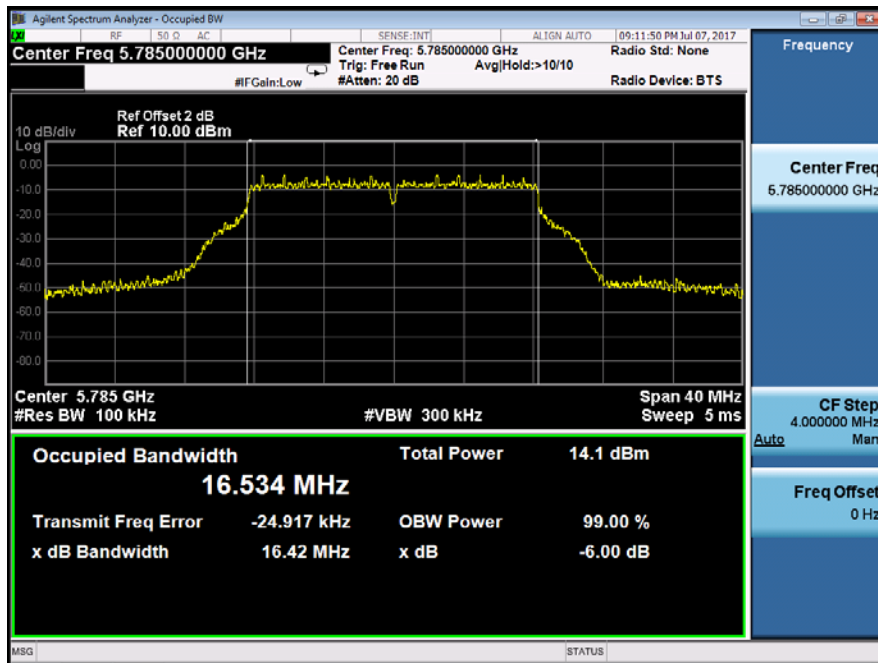

Minimum Emission Bandwidth	UNII Band III	
Test Model	802.11a mode	Frequency(MHz)
Ant0		5825

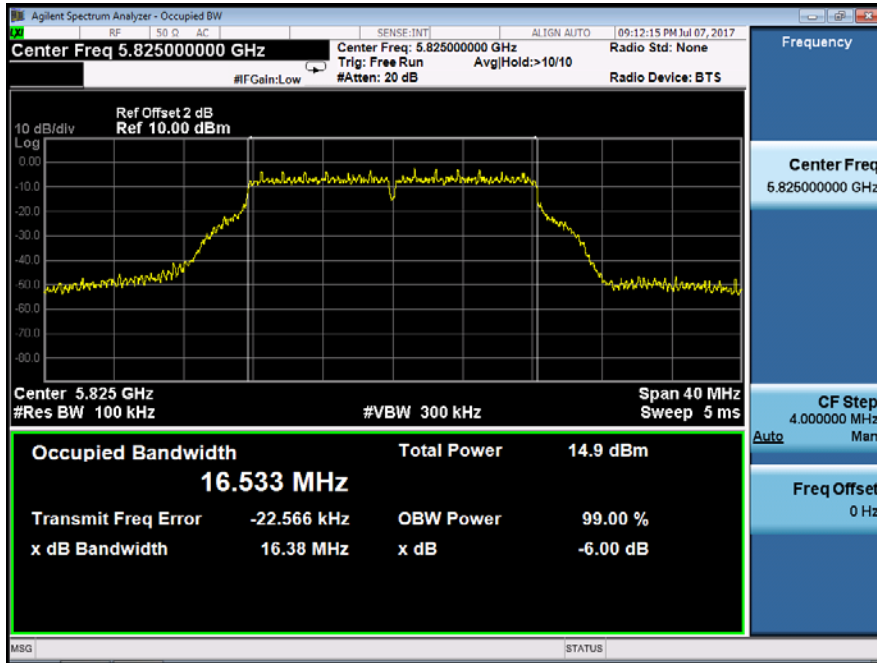

Minimum Emission Bandwidth	UNII Band III	
Test Model	802.11n(VHT20) mode	Frequency(MHz)
Ant0		5745

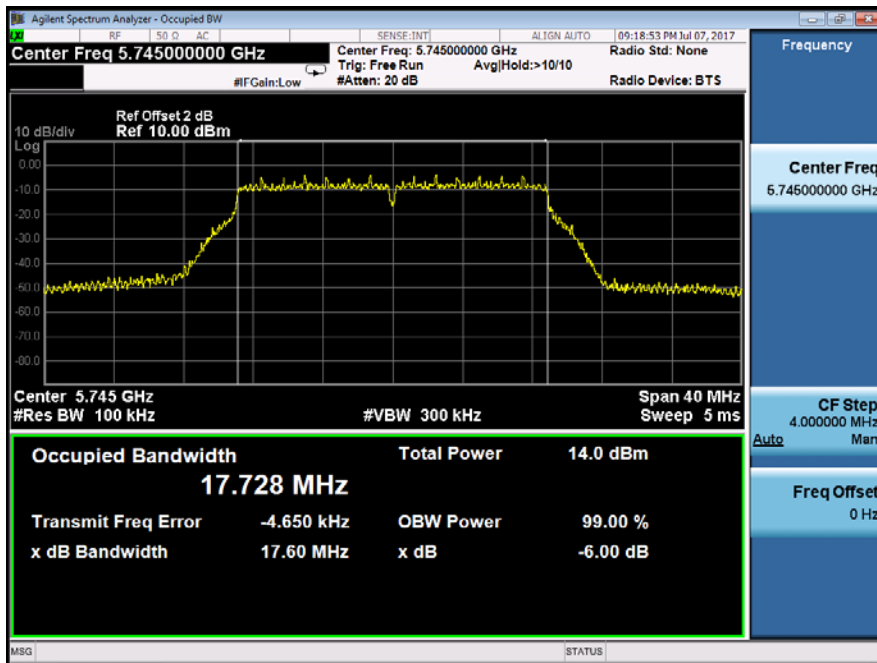

Minimum Emission Bandwidth	UNII Band III	
Test Model	802.11n(VHT20) mode	Frequency(MHz)
Ant0		5785

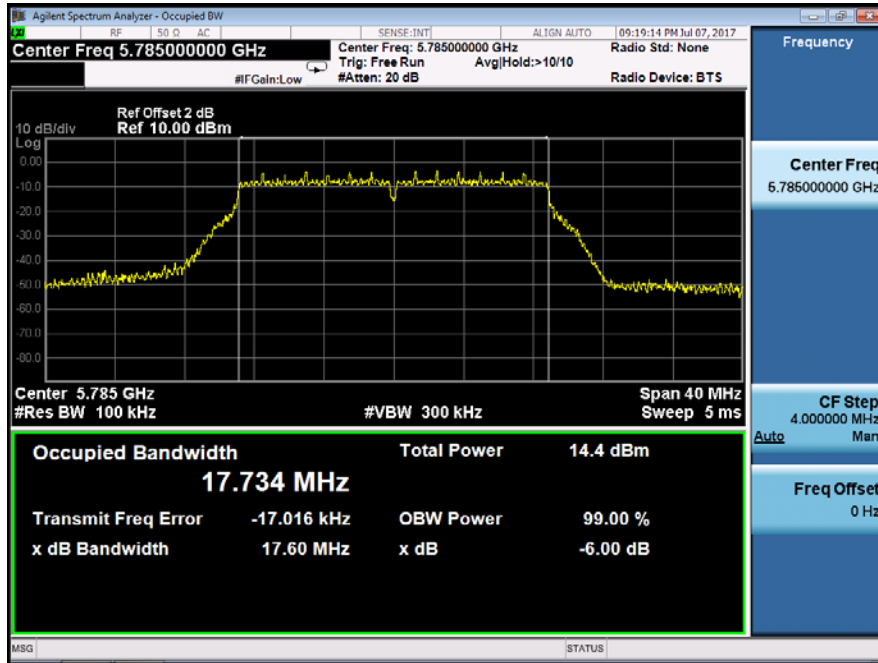

Minimum Emission Bandwidth	UNII Band III	
Test Model	802.11n(VHT20) mode	Frequency(MHz)
Ant0		5825

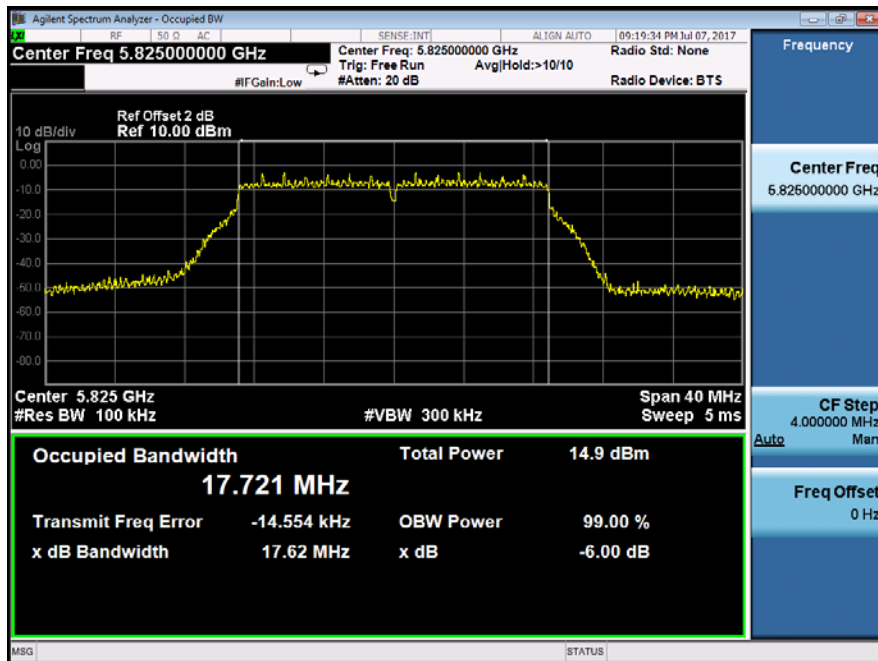

Minimum Emission Bandwidth	UNII Band III	
Test Model	802.11ac(VHT20) mode	Frequency(MHz)
Ant0		5745

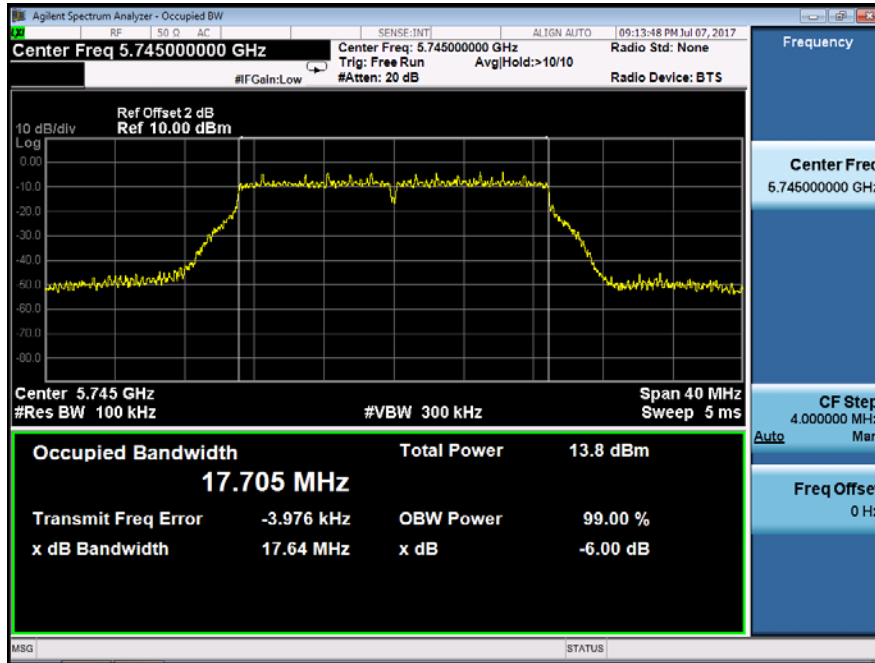

Minimum Emission Bandwidth	UNII Band III	
Test Model	802.11ac(VHT20) mode	Frequency(MHz)
Ant0		5785

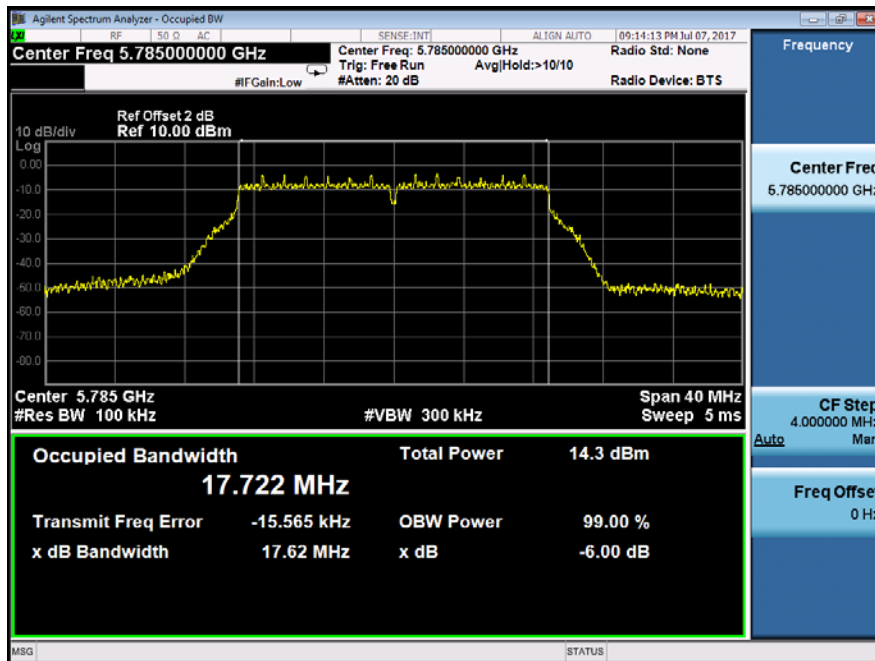

Minimum Emission Bandwidth	UNII Band III		
Test Model	802.11ac(VHT20) mode	Frequency(MHz)	5825
Ant0			



Minimum Emission Bandwidth	UNII Band III		
Test Model	802.11n(VHT40) mode	Frequency(MHz)	5755
Ant0			

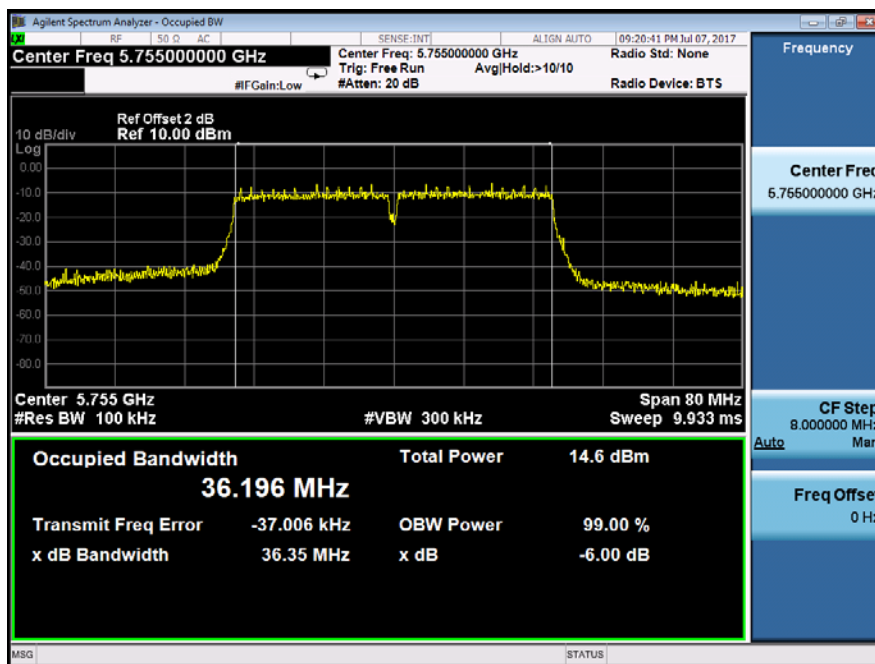

Minimum Emission Bandwidth		UNII Band III	
Test Model	802.11n(VHT40) mode	Frequency(MHz)	5795
Ant0			

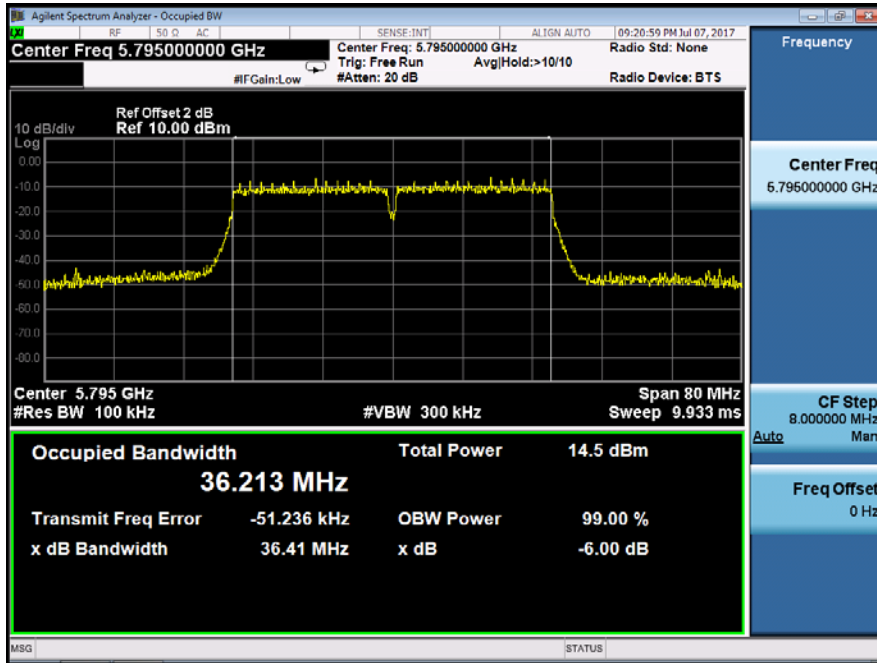

Minimum Emission Bandwidth		UNII Band III	
Test Model	802.11ac(VHT40) mode	Frequency(MHz)	5755
Ant0			

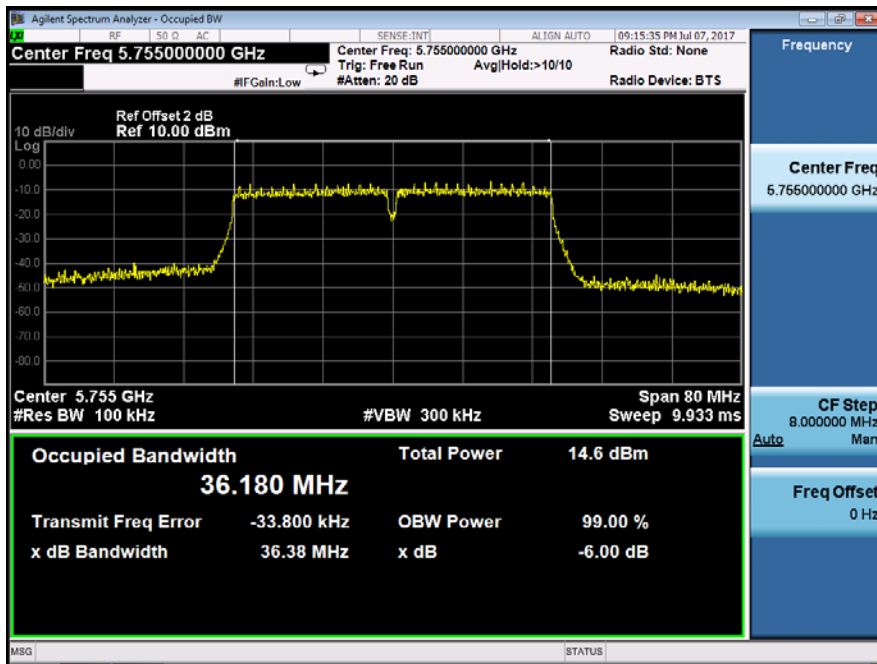

Minimum Emission Bandwidth	UNII Band III	
Test Model	802.11ac(VHT40) mode	Frequency(MHz)
Ant0		5795

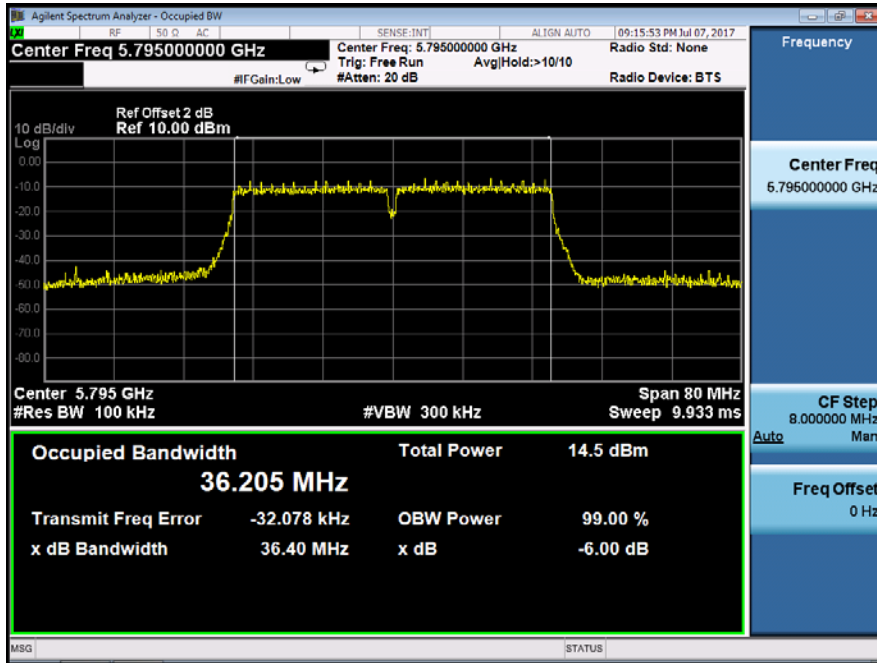

Minimum Emission Bandwidth	UNII Band III	
Test Model	802.11ac(VHT80) mode	Frequency(MHz)
Ant0		5775

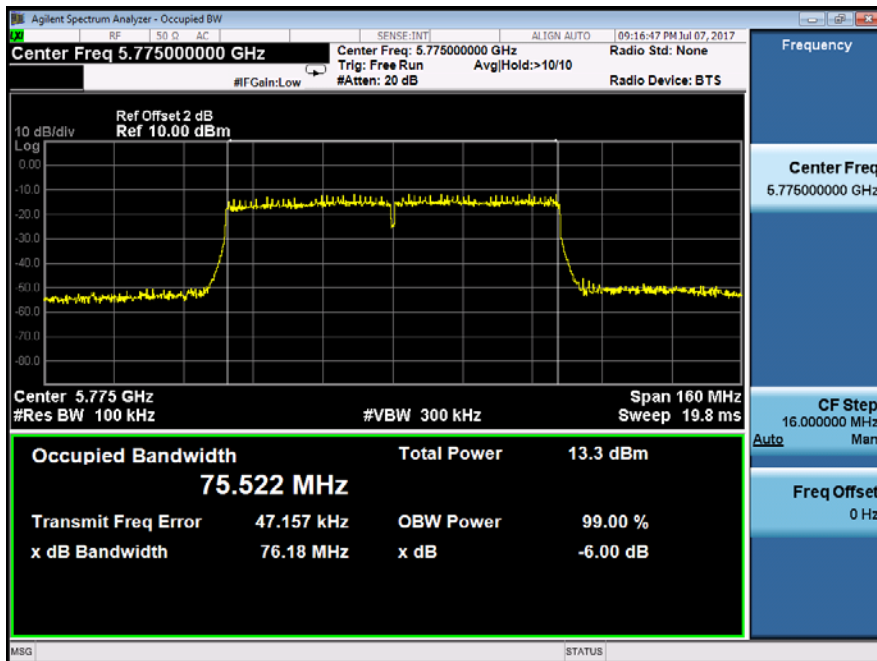

Emission Bandwidth&99% Occupied Bandwidth	UNII Band I
Test Model 802.11a	Frequency(MHz) 5180
Ant1	

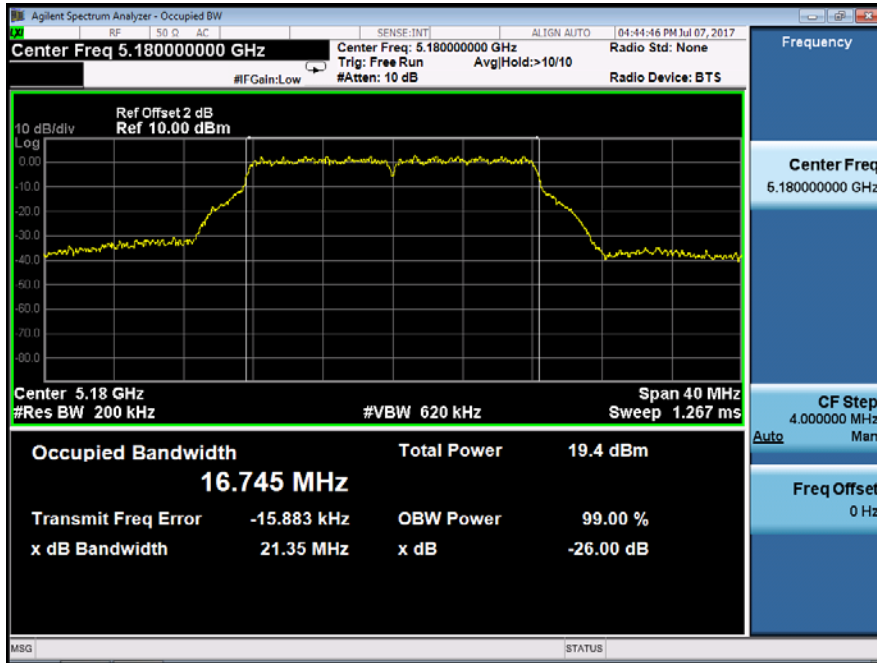

Emission Bandwidth&99% Occupied Bandwidth	UNII Band I
Test Model 802.11a	Frequency(MHz) 5200
Ant1	

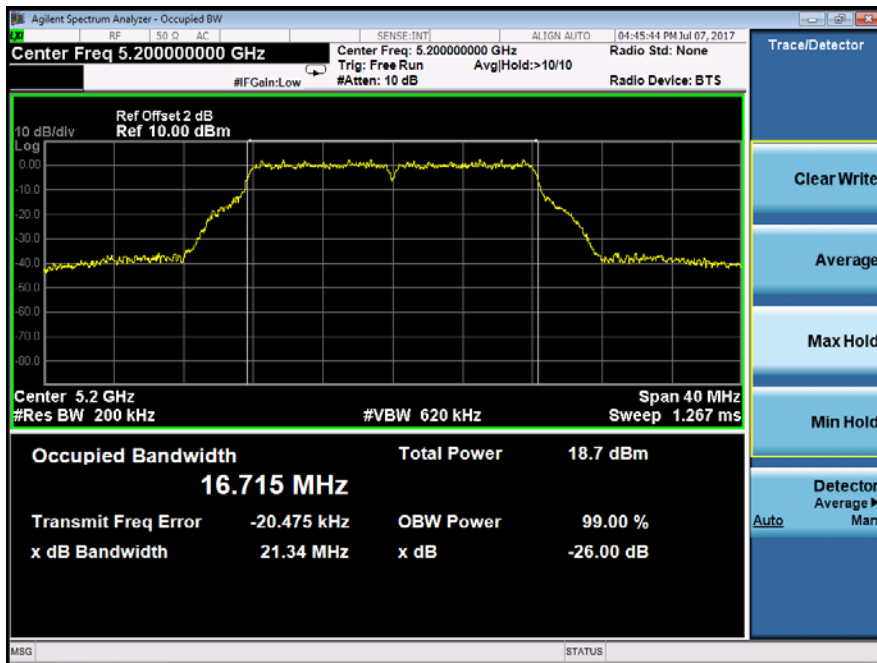

Emission Bandwidth&99% Occupied Bandwidth	UNII Band I
Test Model 802.11a	Frequency(MHz) 5240
Ant1	

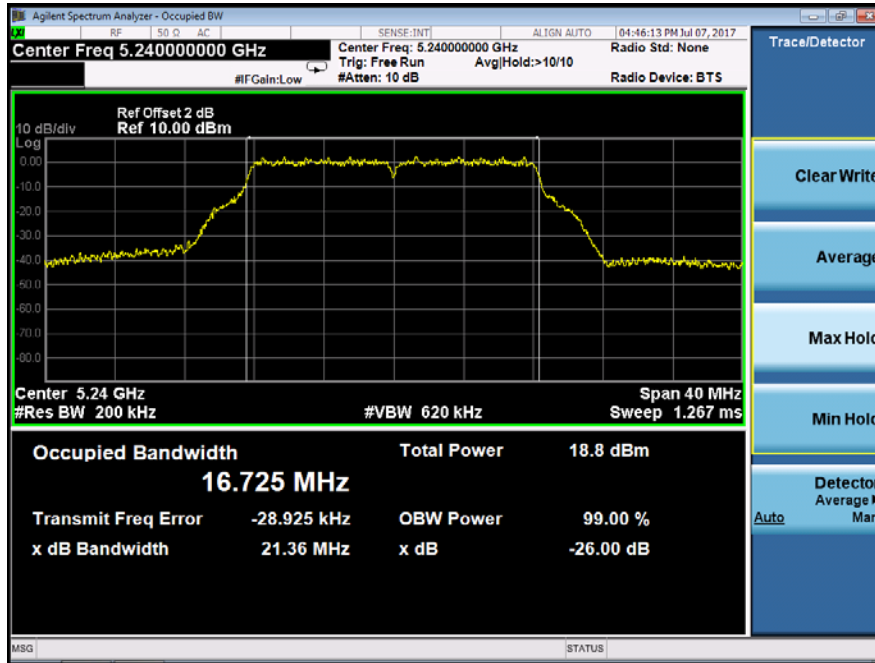

Emission Bandwidth&99% Occupied Bandwidth	UNII Band III
Test Model 802.11a	Frequency(MHz) 5745
Ant1	

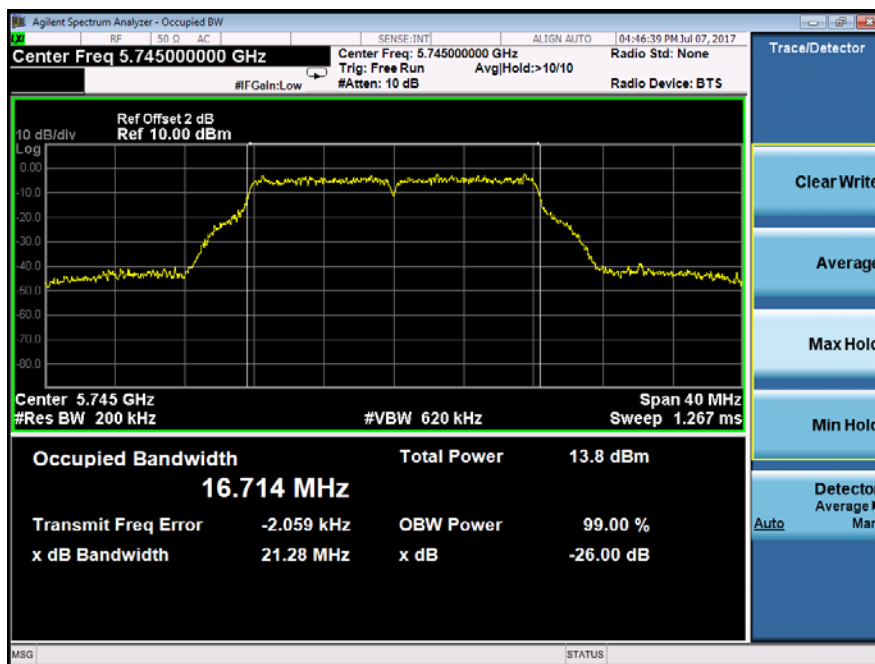

Emission Bandwidth&99% Occupied Bandwidth	UNII Band III
Test Model 802.11a	Frequency(MHz) 5785
Ant1	

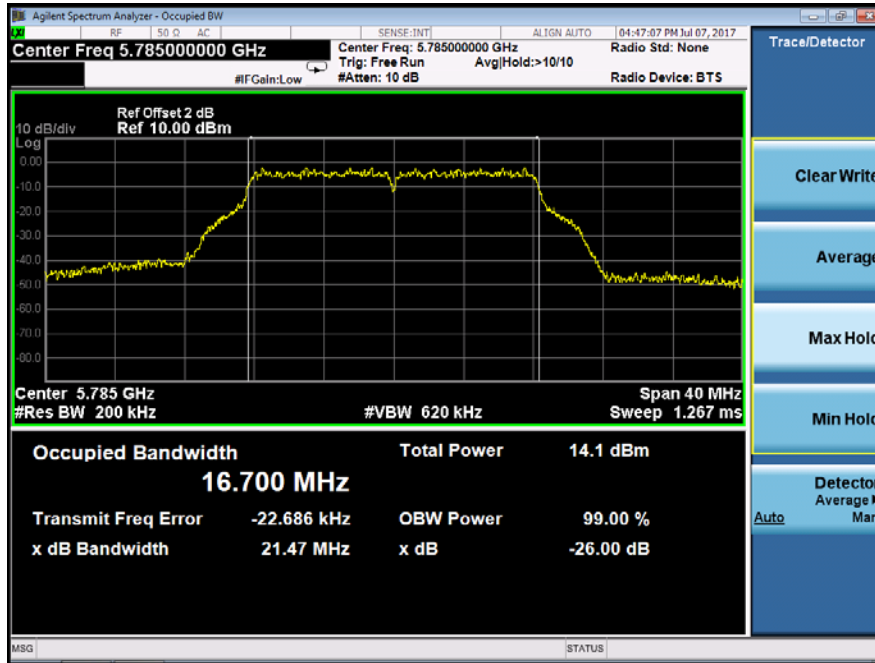

Emission Bandwidth&99% Occupied Bandwidth	UNII Band III
Test Model 802.11a	Frequency(MHz) 5825
Ant1	

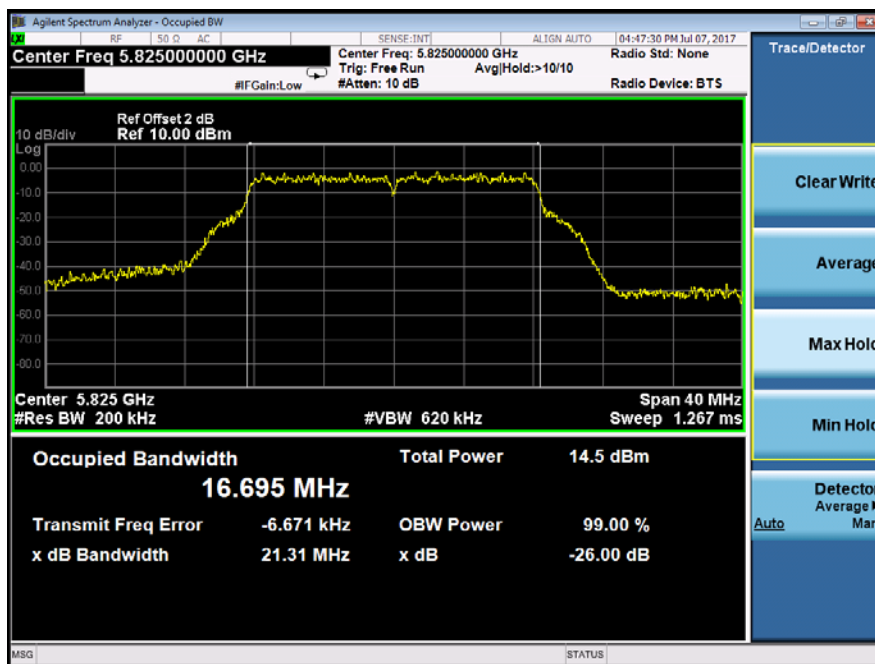

Emission Bandwidth&99% Occupied Bandwidth	UNII Band I	
Test Model	802.11n(VHT20) mode	Frequency(MHz)
Ant1		5180

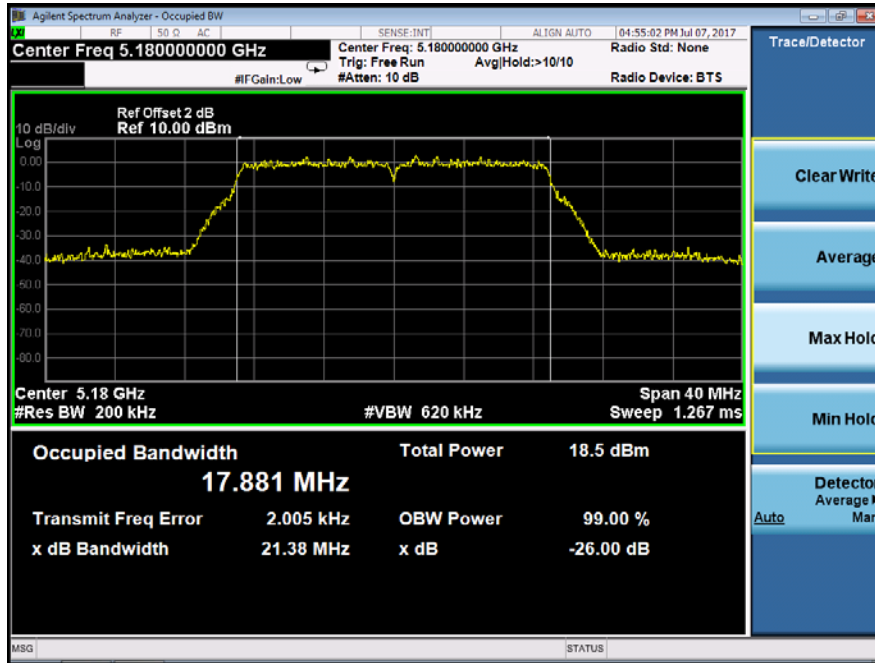

Emission Bandwidth&99% Occupied Bandwidth	UNII Band I	
Test Model	802.11n(VHT20) mode	Frequency(MHz)
Ant1		5200

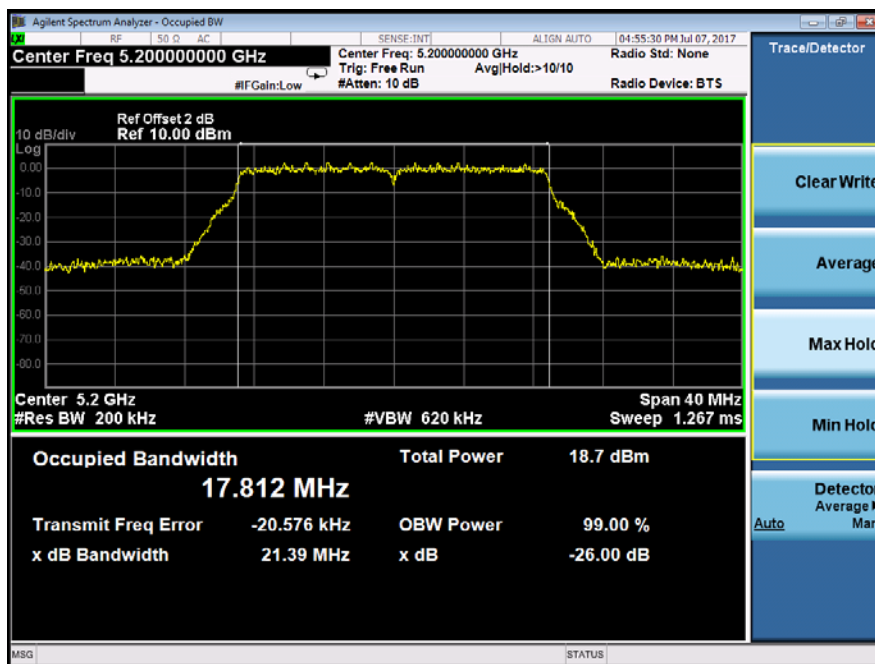

Emission Bandwidth&99% Occupied Bandwidth	UNII Band I	
Test Model	802.11n(VHT20) mode	Frequency(MHz)
Ant1		5240

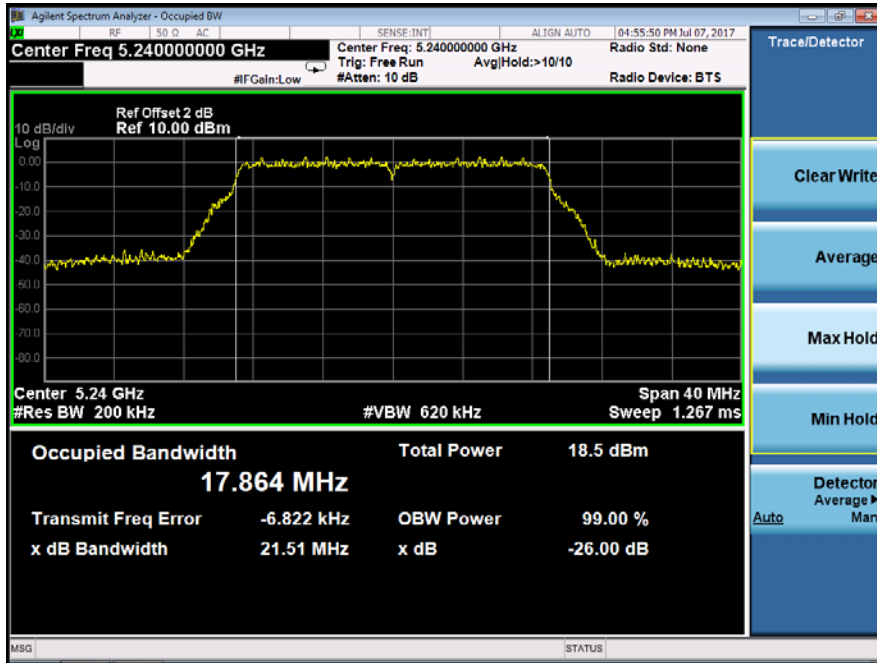

Emission Bandwidth&99% Occupied Bandwidth	UNII Band III	
Test Model	802.11n(VHT20) mode	Frequency(MHz)
Ant1		5745

