

# **FCC CFR47 PART 22H, 24E, 27, 90S CERTIFICATION TEST REPORT FCC ID: 2AOKUTABLET5**

**Product:** Tablet  
**Trade Mark:** HOTWAV  
**Model Number:** TAB R5  
**Family Model:** P2201, P2202, P2201S, P2202S, TAB R5S,  
TAB R6, TAB R6S  
**Report No.:** STR221021003006E

## **Prepared for**

SHENZHEN TUGAO INTELLIGENT CO.,LTD  
8th Floor, Bldg A, Jinggang Science&Technology Park, Fuyong, Bao'an District,  
Shenzhen, China

## **Prepared by**

Shenzhen NTEK Testing Technology Co., Ltd.  
1/F, Building E, Fenda Science Park, Sanwei Community,  
Xixiang Street Bao'an District, Shenzhen 518126 P.R. China  
Tel. 400-800-6106, 0755-2320 0050, 0755-2320 0090  
Website: <http://www.ntek.org.cn>



### TEST RESULT CERTIFICATION

**Applicant's name** ..... : SHENZHEN TUGAO INTELLIGENT CO.,LTD  
**Address** ..... : 8th Floor, Bldg A, Jinggang Science&Technology Park, Fuyong, Bao'an District, Shenzhen, China  
**Manufacturer's Name** ..... : SHENZHEN TUGAO INTELLIGENT CO.,LTD  
**Address** ..... : 8th Floor, Bldg A, Jinggang Science&Technology Park, Fuyong, Bao'an District, Shenzhen, China  
**Product name**..... : Tablet  
**Model and/or type reference** ...: TAB R5  
**Family Model:** P2201, P2202, P2201S, P2202S, TAB R5S, TAB R6, TAB R6S  
**Standards**..... : FCC CFR 47 Part 22H, Part 24E, Part 27, Part 90S  
**Test procedure** .....: ANSI C63.26:2015  
ANSI/TIA-603-E-2016

This device described above has been tested by NTEK, and the test results show that the equipment under test (EUT) is in compliance with the FCC requirements. And it is applicable only to the tested sample identified in the report.

This report shall not be reproduced except in full, without the written approval of NTEK, this document may be altered or revised by NTEK, personal only, and shall be noted in the revision of the document.

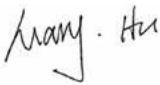
**Test Sample Number**.....: T221021001R001  
**Date of Test** .....  
**Date (s) of performance of tests** ..... Oct 21, 2022 ~ Nov 30, 2022  
**Date of Issue** ..... Nov 30, 2022  
**Test Result**..... **Pass**

Testing Engineer :   
\_\_\_\_\_  
(Mary Hu)  
Authorized Signatory :   
\_\_\_\_\_  
(Alex Li)

## TABLE OF CONTENTS

<b>1. GENERAL INFORMATION</b> .....	<b>6</b>
<b>1. GENERAL INFORMATION</b> .....	<b>6</b>
<b>1.1 PRODUCT DESCRIPTION</b> .....	<b>6</b>
<b>1.2 RELATED SUBMITTAL(S) / GRANT (S)</b> .....	<b>8</b>
<b>1.3 TEST METHODOLOGY</b> .....	<b>8</b>
<b>1.4 TEST FACILITY</b> .....	<b>8</b>
<b>MEASUREMENT UNCERTAINTY</b> .....	<b>8</b>
<b>1.5 SPECIAL ACCESSORIES</b> .....	<b>8</b>
<b>1.6 WORST-CASE CONFIGURATION AND MODE</b> .....	<b>8</b>
<b>2. SYSTEM TEST CONFIGURATION</b> .....	<b>9</b>
<b>2.1 EUT CONFIGURATION</b> .....	<b>9</b>
<b>2.2 EUT EXERCISE</b> .....	<b>9</b>
<b>2.3 CONFIGURATION OF EUT SYSTEM</b> .....	<b>9</b>
<b>2.4 TEST SETUP</b> .....	<b>10</b>
<b>3.TEST AND MEASUREMENT EQUIPMENT</b> .....	<b>11</b>
<b>4. OUTPUT POWER</b> .....	<b>13</b>
<b>4.1 OUTPUT POWER MEASUREMENT</b> .....	<b>13</b>
<b>6. BANDEDGE AND EMISSION MASK</b> .....	<b>16</b>
<b>7. OUT OF BAND EMISSIONS</b> .....	<b>18</b>
<b>7.1 MEASUREMENT METHOD</b> .....	<b>18</b>
<b>8. RADIATED MEASUREMENT</b> .....	<b>19</b>
<b>8.1. RADIATED POWER (ERP &amp; EIRP)</b> .....	<b>19</b>
<b>8.2 LTE BAND 2</b> .....	<b>20</b>
<b>8.3 LTE BAND 4</b> .....	<b>24</b>
<b>8.4 LTE BAND 5</b> .....	<b>28</b>

<b>8.5 LTE BAND 7</b> .....	<b>30</b>
<b>8.6 LTE BAND 12</b> .....	<b>32</b>
<b>8.7 LTE BAND 17</b> .....	<b>34</b>
<b>8.8 LTE BAND 25</b> .....	<b>36</b>
<b>8.9 LTE BAND 26</b> .....	<b>40</b>
<b>8.10 LTE BAND 26</b> .....	<b>42</b>
<b>8.11 LTE BAND 41</b> .....	<b>44</b>
<b>8.12 LTE BAND 66</b> .....	<b>46</b>
<b>9. SPURIOUS RADIATION EMISSION</b> .....	<b>50</b>
<b>9.1 LTE BAND 2</b> .....	<b>52</b>
<b>9.2 LTE BAND 4</b> .....	<b>54</b>
<b>9.3 LTE BAND 5</b> .....	<b>56</b>
<b>9.4 LTE BAND 7</b> .....	<b>58</b>
<b>9.5 LTE BAND 12</b> .....	<b>60</b>
<b>9.6 LTE BAND 17</b> .....	<b>62</b>
<b>9.7 LTE BAND 25</b> .....	<b>64</b>
<b>9.8 LTE BAND 26</b> .....	<b>66</b>
<b>9.9 LTE BAND 41</b> .....	<b>69</b>
<b>9.10 LTE BAND 66</b> .....	<b>71</b>
<b>10. FREQUENCY STABILITY</b> .....	<b>73</b>
<b>10.1 LTE BAND 2</b> .....	<b>74</b>
<b>10.2 LTE BAND 4</b> .....	<b>76</b>
<b>10.3 LTE BAND 5</b> .....	<b>78</b>
<b>10.4 LTE BAND 7</b> .....	<b>80</b>
<b>10.5 LTE BAND 12</b> .....	<b>82</b>
<b>10.6 LTE BAND 17</b> .....	<b>84</b>
<b>10.7 LTE BAND 25</b> .....	<b>86</b>
<b>10.8 LTE BAND 26</b> .....	<b>88</b>
<b>10.9 LTE BAND 41</b> .....	<b>92</b>

**10.10 LTE BAND 66..... 94**

**11. PEAK-TO-AVERAGE RATIO .....96**

**11.1 Description of the PAR Measurement ..... 96**

**11.2 Measuring Instruments ..... 96**

**11.3 Test Procedures..... 96**

**11.4 Test Setup..... 97**

## 1. GENERAL INFORMATION

### 1.1 PRODUCT DESCRIPTION

A major technical description of EUT is described as following:

Product Designation:	Tablet
Trade Mark	HOTWAV
Model Name	TAB R5
Family Model	P2201, P2202, P2201S, P2202S, TAB R5S, TAB R6, TAB R6S
Model Difference	All models are the same circuit and RF module, except the model name and colors.
FCC ID:	2AOKUTABLET5
Frequency Bands:	U.S. Bands: <input checked="" type="checkbox"/> LTE FDD Band 2,4,5,7,12, 17,25,26, 66, TDD Band 41
Frequency Range:	LTE FDD Band 2 Uplink: 1850MHz-1910MHz, Downlink: 1930MHz-1990MHz; LTE FDD Band 4 Uplink: 1710MHz-1755MHz, Downlink: 2110MHz-2155MHz; LTE FDD Band 5 Uplink: 824MHz-849MHz, Downlink: 869MHz-894MHz; LTE-FDD Band 7 Uplink: 2500MHz-2570MHz, Downlink: 2620MHz-2690MHz; LTE FDD Band 12 Uplink: 699MHz-716MHz, Downlink: 729MHz-746MHz; LTE FDD Band 17 Uplink: 704MHz-716MHz, Downlink: 734MHz-746MHz; LTE FDD Band 25 Uplink: 1850MHz-1915MHz, Downlink: 1930MHz-1995MHz; LTE FDD Band 26 Uplink: 814MHz-849MHz, Downlink: 859MHz-894MHz; LTE TDD Band 41 Uplink& Downlink: 2535MHz-2655MHz(see Note 2), LTE FDD Band 66 Uplink: 1710MHz-1780MHz, Downlink: 2110MHz-2200MHz;
Type of Modulation:	QPSK/16QAM
SIM Card	SIM 1 and SIM 2 is a chipset unit and tested as a single chipset. The SIM 1 is chosen for test.
Antenna:	PIFA Antenna
Antenna gain:	Band 2: -0.31dBi; Band 4: -0.34dBi ; Band 5: -0.57dBi ; Band 7: -0.37dBi ; Band 12: -0.61dBi ; Band 17: -0.63dBi; Band 25: -0.31dBi; Band 26: -0.61dBi; Band 41: -0.46dBi; Band 66: -0.31dBi;
Power Supply:	DC 3.85V from battery or DC 5V from Adapter.

Adapter:	Model: HJ-0502000W2-US Input: 100-240V~50/60Hz 0.3A Output: 5.0V $\overline{\text{---}}$ 2.0A 10.0W
Extreme Vol. Limits:	DC 3.4V to DC 4.2V (Nominal DC 3.85V) (Note 1)
HW Version	TP717_MAIN_PCB_V1.2A
SW Version	HOTWAV_TAB R5_V3.0_20221115
** Note1: The High Voltage DC 4.2V and Low Voltage 3.4V was declared by manufacturer, The EUT couldn't be operate normally with higher or lower voltage.	

Note 2

Band	Bandwidth (MHz)	UL Channel	Frequency (MHz)
Band 41	5	40065	2537.5
		40640	2595
		41215	2652.5
	10	40090	2540
		40640	2595
		41190	2650
	15	40115	2542.5
		40640	2595
		41165	2647.5
	20	40140	2545
		40640	2595
		41140	2645

**1.2 RELATED SUBMITTAL(S) / GRANT (S)**

This submittal(s) (test report) is intended for **FCC ID: 2AOKUTABLET5** filing to comply with the FCC Part 22H&24E&27&90S.

**1.3 TEST METHODOLOGY**

The tests documented in this report were performed in accordance with ANSI/TIA-603-E-2016, FCC CFR 47 Part 2, Part 22, Part 24, Part 27, Part 90S,ANSI C63.26:2015.

**1.4 TEST FACILITY**

The test site used to collect the radiated data is located at:

ShenZhen NTEK Testing Technology Co., Ltd.

1/F, Building E, Fenda Science Park, Sanwei Community, Xixiang Street, Bao'an District, Shenzhen 518126 P.R.China.

The test site is constructed and calibrated to meet the FCC requirements in documents ANSI C63.26:2015& ANSI C63.4: 2014.

FCC Registration No.:463705

IC Registration No.:9270A-1,

CNAS Registration No.:L5516

**MEASUREMENT UNCERTAINTY**

The reported uncertainty of measurement, where expended uncertainty U is based on a standard uncertainty multiplied by a coverage factor of k=2, providing a level of confidence of approximately 95 %.

No.	Item	Uncertainty
1	Measuring Uncertainty for a Level of Confidence of 95% ( $U = 2Uc(y)$ )	2.5dB

**1.5 SPECIAL ACCESSORIES**

The battery and the charger, earphone supplied by the applicant were used as accessories and being tested with EUT intended for FCC grant together.

**1.6 WORST-CASE CONFIGURATION AND MODE**

The worst-case scenario for all measurements is based on the investigation results.

The device has LTE Bands of: Band 2, Band 4, Band 5, Band 7, Band 12, Band 17, Band 25, Band 26, Band 41, Band 66.

The RB Size was selected to measure for peak or average ERP and EIRP, which was based on the conducted power verification baseline data.

For the fundamental investigation of radiated emissions, the EUT is investigated for vertical and horizontal antenna orientations and X Y and Z orientations of the EUT alone. After the investigations



the worst case was determined to be at X orientation for all LTE bands.

## 2. SYSTEM TEST CONFIGURATION

### 2.1 EUT CONFIGURATION

The EUT configuration for testing is installed on RF field strength measurement to meet the Commission's requirement and operating in a manner which intends to maximize its emission characteristics in a continuous normal application.

### 2.2 EUT EXERCISE

The Transmitter was operated in the maximum output power mode through Communication Tester. The TX frequency was fixed which was for the purpose of the measurements.

### 2.3 CONFIGURATION OF EUT SYSTEM

Table 2-1 Equipment Used in EUT System

Item	Equipment	Model No.	ID or Specification	Note
1	Tablet	TAB R5	FCC ID: 2AOKUTABLET5	EUT

*Note: All the accessories have been used during the test.  
the following "EUT" in setup diagram means EUT system.*

## 2.4 TEST SETUP

For Radiated Test Cases

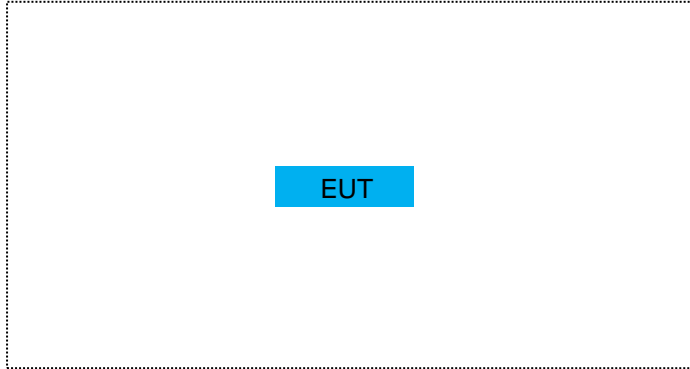

For Conducted Output Power

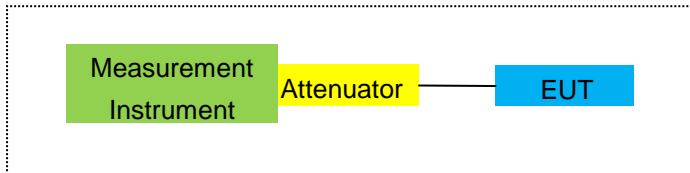

For Peak-to Average Ratio, Occupied Bandwidth, Conducted Band edge and Conducted Spurious Emission

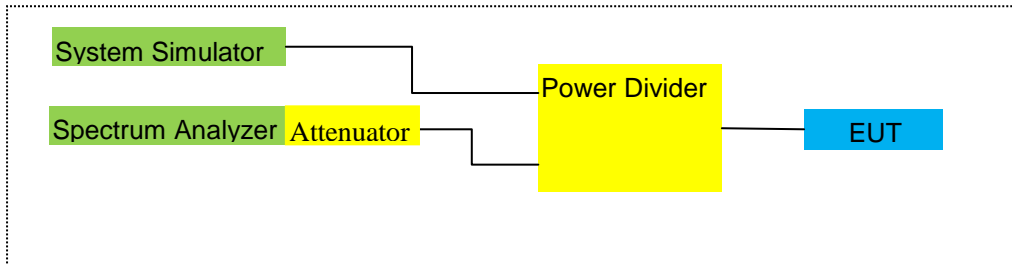

For Frequency Stability

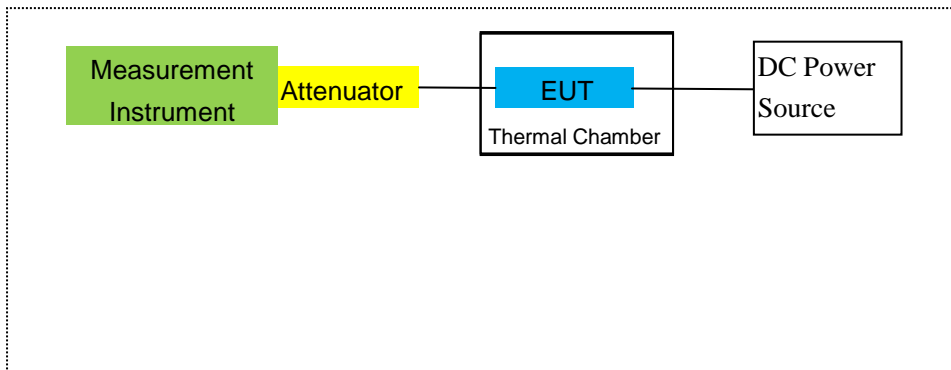

Note: EUT built-in battery-powered, the battery is fully-charged.

### 3. TEST AND MEASUREMENT EQUIPMENT

The following test and measurement equipment was utilized for the tests documented in this report:

Item	Kind of Equipment	Manufacturer	Type No.	Serial No.	Last calibration	Calibrated until	Calibration period
1	MXA Signal Analyzer	Agilent	N9020A	MY49100060	2022.04.06	2023.04.05	1 year
2	Test Receiver	R&S	ESPI	101318	2022.04.06	2023.04.05	1 year
3	Bilog Antenna	TESEQ	CBL6111D	31216	2022.03.30	2023.03.29	1 year
4	50Ω Coaxial Switch	Anritsu	MP59B	6200983705	2020.05.11	2023.05.10	3 year
5	Horn Antenna	EM	EM-AH-10180	2011071402	2022.03.31	2023.03.30	1 year
6	Horn Ant	Schwarzbeck	BBHA 9170	9170-181	2022.06.17	2023.06.16	1 year
7	Amplifier	EM	EM-30180	060538	2022.06.17	2023.06.16	1 year
8	Loop Antenna	ARA	PLA-1030/B	1029	2022.04.06	2023.04.05	1 year
9	Power Meter	R&S	NRVS	100696	2022.06.17	2023.06.16	1 year
10	Power Sensor	R&S	URV5-Z4	0395.1619.05	2022.04.06	2023.04.05	1 year
11	Test Cable	N/A	R-01	N/A	2020.05.11	2023.05.10	3 year
12	Test Cable	N/A	R-02	N/A	2020.05.11	2023.05.10	3 year
13	Test Cable	N/A	R-03	N/A	2022.06.17	2025.06.16	3 year
14	Test Receiver	R&S	ESCI	101160	2022.04.06	2023.04.05	1 year
15	LISN	R&S	ENV216	101313	2022.04.06	2023.04.05	1 year
16	LISN	EMCO	3816/2	00042990	2022.04.06	2023.04.05	1 year
17	50Ω Coaxial Switch	Anritsu	MP59B	6200264417	2022.04.06	2023.04.05	1 year
18	Passive Voltage Probe	R&S	ESH2-Z3	100196	2022.04.06	2023.04.05	1 year
19	Test Cable	N/A	C01	N/A	2020.05.11	2023.05.10	3 year
20	Test Cable	N/A	C02	N/A	2020.05.11	2023.05.10	3 year
21	Test Cable	N/A	C03	N/A	2020.05.11	2023.05.10	3 year
22	Attenuator	MCE	24-10-34	BN9258	2022.06.17	2023.06.16	1 year
23	Spectrum Analyzer	agilent	e4440a	us44300399	2022.04.06	2023.04.05	1 year
24	test receiver	R&S	ESCI	a0304218	2022.04.06	2023.04.05	1 year
25	Communication Tester	R&S	CMU200	A0304247	2022.06.17	2023.06.16	1 year
26	Thermal Chamber	Ten Billion	TTC-B3C	TBN-960502	2022.04.06	2023.04.05	1 year

27	DC Power Source	N/A	PS-6005D	2017040292 3	2020.05.11	2023.05.10	3 year
28	PSG Analog Signal Generator	Agilent	E8257D	MY51110112	2022.06.16	2023.06.15	1 year
29	Communication Tester	R&S	CMW500	148500	2022.06.16	2023.06.15	1 year

Note: Each piece of equipment is scheduled for calibration once a year except the Test Cable& DC Power Source which is scheduled for calibration every 3 years.

## 4. OUTPUT POWER

### 4.1 OUTPUT POWER MEASUREMENT

#### LTE Measurement Procedure:

All LTE bands conducted power peak and average are obtained from the CMW500 telecommunication test set. The following tests were conducted according to the test requirements outlined in section 6.2 of the 3GPP TS36.101 specification.

UE Power Class: 3 (23 +/- 2dBm). The allowed Maximum Power Reduction (MPR) for the maximum output power due to higher order modulation and transmit bandwidth configuration (resource blocks) is specified in Table 6.2.3-1 of the 3GPP TS36.101.

**Table 6.2.3-1: Maximum Power Reduction (MPR) for Power Class 3**

Modulation	Channel bandwidth / Transmission bandwidth (RB)						MPR (dB)
	1.4 MHz	3.0 MHz	5 MHz	10 MHz	15 MHz	20 MHz	
QPSK	> 5	> 4	> 8	> 12	> 16	> 18	≤ 1
16 QAM	≤ 5	≤ 4	≤ 8	≤ 12	≤ 16	≤ 18	≤ 1
16 QAM	> 5	> 4	> 8	> 12	> 16	> 18	≤ 2

The allowed A-MPR values specified below in Table 6.2.4.-1 of 3GPP TS36.101 are in addition to the allowed MPR requirements. All the measurements below were performed with A-MPR disabled, by using Network Signaling Value of "NS\_01".3

**Table 6.2.4-1: Additional Maximum Power Reduction (A-MPR)**

Network Signalling value	Requirements (sub-clause)	E-UTRA Band	Channel bandwidth (MHz)	Resources Blocks ( $N_{RB}$ )	A-MPR (dB)
NS_01	6.6.2.1.1	Table 5.5-1	1.4, 3, 5, 10, 15, 20	Table 5.6-1	NA
NS_03	6.6.2.2.1	2, 4, 10, 23, 25, 35, 36	3	>5	$\leq 1$
			5	>6	$\leq 1$
			10	>6	$\leq 1$
			15	>8	$\leq 1$
			20	>10	$\leq 1$
NS_04	6.6.2.2.2	41	5	>6	$\leq 1$
			10, 15, 20	See Table 6.2.4-4	
NS_05	6.6.3.3.1	1	10,15,20	$\geq 50$	$\leq 1$
NS_06	6.6.2.2.3	12, 13, 14, 17	1.4, 3, 5, 10	Table 5.6-1	n/a
NS_07	6.6.2.2.3	13	10	Table 6.2.4-2	Table 6.2.4-2
	6.6.3.3.2				
NS_08	6.6.3.3.3	19	10, 15	> 44	$\leq 3$
NS_09	6.6.3.3.4	21	10, 15	> 40	$\leq 1$
				> 55	$\leq 2$
NS_10		20	15, 20	Table 6.2.4-3	Table 6.2.4-3
NS_11	6.6.2.2.1	23 <sup>1</sup>	1.4, 3, 5, 10	Table 6.2.4-5	Table 6.2.4-5
..					
NS_32	-	-	-	-	-

Note 1: Applies to the lower block of Band 23, i.e. a carrier placed in the 2000-2010 MHz region.

Test data reference attachment.

## 5. OCCUPIED BANDWIDTH

### RULE PART(S)

FCC: §2.1049

### LIMITS

For reporting purposes only

### TEST PROCEDURE

The transmitter output was connected to a calibrated coaxial cable and coupler, the other end of which was connected to a spectrum analyzer. The occupied bandwidth was measured with the spectrum analyzer at the low, middle and high channel in each band. The -26dB bandwidth was also measured and recorded.

### MODES TESTED

- LTE Band 2
- LTE Band 4
- LTE Band 5
- LTE Band 7
- LTE Band 12
- LTE Band 17
- LTE Band 25,
- LTE Band 26,
- LTE Band 41
- LTE Band 66

### RESULTS

**PASS**

Test data reference attachment.

## 6. BANDEDGE AND EMISSION MASK

### RULE PART(S)

FCC: §2.1051, §22.901, §22.917, §24.238, §27.53, and §90.691

FCC: §22.359

### LIMITS

FCC: §22.917, §24.238, §27.53

The power of any emission outside of the authorized operating frequency ranges must be attenuated below the transmitting power (P) by a factor of at least  $43 + 10 \log (P)$  dB.

(m)(4) For mobile digital stations, the attenuation factor shall be not less than  $40 + 10 \log (P)$  dB on all frequencies between the channel edge and 5 megahertz from the channel edge,  $43 + 10 \log (P)$  dB on all frequencies between 5 megahertz and X megahertz from the channel edge, and  $55 + 10 \log (P)$  dB on all frequencies more than X megahertz from the channel edge, where X is the greater of 6 megahertz or the actual emission bandwidth as defined in paragraph (m)(6) of this section. In addition, the attenuation factor shall not be less that  $43 + 10 \log (P)$  dB on all frequencies between 2490.5 MHz and 2496 MHz and  $55 + 10 \log (P)$  dB at or below 2490.5 MHz. Mobile Satellite Service licensees operating on frequencies below 2495 MHz may also submit a documented interference complaint against BRS licensees operating on channel BRS Channel 1 on the same terms and conditions as adjacent channel BRS or EBS licensees. Show citation box.

(c)(4) On all frequencies between 763-775 MHz and 793-805 MHz, by a factor not less than  $65 + 10 \log (P)$  dB in a 6.25 kHz band segment, for mobile and portable stations;

FCC: §90.691 Emission mask requirements for EA-based systems.

(a) Out-of-band emission requirement shall apply only to the “outer” channels included in an EA license and to spectrum adjacent to interior channels used by incumbent licensees. The emission limits are as follows:

(1) For any frequency removed from the EA licensee's frequency block by up to and including 37.5 kHz, the power of any emission shall be attenuated below the transmitter power (P) in watts by at least  $116 \log_{10}(f/6.1)$  decibels or  $50 + 10 \log_{10}(P)$  decibels or 80 decibels, whichever is the lesser attenuation, where f is the frequency removed from the center of the outer channel in the block in kilohertz and where f is greater than 12.5 kHz.

(2) For any frequency removed from the EA licensee's frequency block greater than 37.5 kHz, the power of any emission shall be attenuated below the transmitter power (P) in watts by at least  $43 + 10 \log_{10}(P)$  decibels or 80 decibels, whichever is the lesser attenuation, where f is the frequency removed from the center of the outer channel in the block in kilohertz and where f is greater than 37.5 kHz.



**TEST PROCEDURE**

The transmitter output was connected to a CMW500 Test Set and configured to operate at maximum power. The band edge emissions were measured at the required operating frequencies in each band on the Spectrum Analyzer.

For each band edge measurement:

Set the spectrum analyzer span to include the block edge frequency

Set a marker to point the corresponding band edge frequency in each test case.

Set resolution bandwidth to at least 1% of emission bandwidth.

**MODES TESTED**

- LTE Band 2
- LTE Band 4
- LTE Band 5
- LTE Band 7
- LTE Band 12
- LTE Band 17
- LTE Band 25,
- LTE Band 26,
- LTE Band 41
- LTE Band 66

**RESULTS**

Test data reference attachment.

## 7. OUT OF BAND EMISSIONS

### RULE PART(S)

FCC: §2.1051, §22.901, §22.917, §24.238, §27.53 and §90.691

### LIMITS

1. The power of any emission outside of the authorized operating frequency ranges must be attenuated below the transmitting power (P) by a factor of at least  $43 + 10 \log (P)$  dB.
2. The Band 7/41 emission outside of the authorized operating frequency ranges must be attenuated below the transmitting power (P) by a factor of at least  $55 + 10 \log (P)$  dB.

### TEST PROCEDURE

The RF output of the transmitter was connected to a spectrum analyzer through a calibrated coaxial cable. Sufficient scans were taken to show the out-of-band Emissions, if any, up to 10th harmonic. Multiple sweeps were recorded in maximum hold mode using a peak detector to ensure that the worst-case emissions were caught.

For each out of band emissions measurement:

- 
- Set RBW & VBW to 100 kHz for the measurement below 1 GHz, and 1 MHz for the measurement above 1 GHz.

### **MODES TESTED**

- LTE Band 2/4/5/7/12/17/25/26/41/66
- 

### 7.1 MEASUREMENT METHOD

The test set up and general procedure is similar to conducted peak output power test. Only different for setting the measurement configuration of the measuring instrument of Spectrum Analyzer.

Test data reference attachment.

## 8. RADIATED MEASUREMENT

### 8.1. RADIATED POWER (ERP & EIRP)

#### RULE PART(S)

FCC: §2.1046, §22.913, §24.232, §27.50 and §90.635

#### LIMITS:

22.913(a) - The ERP of mobile transmitters and auxiliary test transmitters must not exceed 7 Watts.

27.50 (c) (10) the following power and antenna height requirements apply to stations transmitting in the 698–746 MHz band, the portable stations (hand-held devices) are limited to 3 watts ERP.

27.50 (b)(10) Portable stations (hand-held devices) transmitting in the 746–757 MHz, 758–763 MHz, 776–793 MHz, and 805–806 MHz bands are limited to 3 watts ERP.

27.50 (d)(4) The following power and antenna height requirements apply to stations transmitting in the 1710–1755 MHz and 2110–2155 MHz bands: Fixed, mobile, and portable (hand-held) stations operating in the 1710–1755 MHz band are limited to 1 watt EIRP.

27.50 (h)(2) Mobile and other user stations. Mobile stations are limited to 2.0 watts EIRP. All user stations are limited to 2.0 watts transmitter output power.

90.635(b) The maximum output power of the transmitter for mobile stations is 100 watts (20 dBw).

#### TEST PROCEDURE

ANSI/TIA-603-E Clause 2.2.17

KDB 971168 v02r01 RF power output using broadband peak and average power meter method.

KDB 971168 D01 Power Meas License Digital Systems v02r01, "Measurement Guidance for Certification of Licensed Digital Transmitters"

#### MODES TESTED

- LTE Band 2/4/5/7/12/17/25/26/41/66

#### RESULTS

Pass

8.2 LTE BAND 2

Radiated Power (EIRP) for Band 2									
Mode	RB/RB SIZE	Frequency	Result						Conclusion
			SG Level (dBm)	Cable Loss (dBm)	Factor Gain (dB)	Max. EIRP Average (dBm)	Max. EIRP Average (mW)	Polarization Of Max. ERP	
1.4MHz Band QPSK	6/0	1850.7	17.11	3.76	8.90	22.25	167.88	Horizontal	Pass
		1880	16.34	3.91	8.90	21.33	135.83	Horizontal	Pass
		1909.3	14.67	3.93	8.90	19.64	92.04	Horizontal	Pass
3.0MHz Band QPSK	15/0	1851.5	15.89	3.77	8.90	21.02	126.47	Horizontal	Pass
		1880	15.67	3.91	8.90	20.66	116.41	Horizontal	Pass
		1908.5	16.62	3.94	8.90	21.58	143.88	Horizontal	Pass
5.0MHz Band QPSK	25/0	1852.5	15.77	3.77	8.90	20.9	123.03	Horizontal	Pass
		1880	17.27	3.91	8.90	22.26	168.27	Horizontal	Pass
		1907.5	15.96	3.94	8.90	20.92	123.59	Horizontal	Pass
10.0MHz Band QPSK	50/0	1855	16.86	3.79	8.90	21.97	157.40	Horizontal	Pass
		1880	16.68	3.95	8.90	21.63	145.55	Horizontal	Pass
		1905	16.66	3.97	8.90	21.59	144.21	Horizontal	Pass
15.0MHz Band QPSK	75/0	1857.5	15.91	3.79	8.90	21.02	126.47	Horizontal	Pass
		1880	17.30	3.95	8.90	22.25	167.88	Horizontal	Pass
		1902.5	16.88	3.97	8.90	21.81	151.71	Horizontal	Pass
20.0MHz Band QPSK	100/0	1860	16.44	3.81	8.90	21.53	142.23	Horizontal	Pass
		1880	16.39	3.96	8.90	21.33	135.83	Horizontal	Pass
		1900	16.67	4.00	8.90	21.57	143.55	Horizontal	Pass
1.4MHz Band QPSK	6/0	1850.7	16.62	3.76	8.90	21.76	149.97	Vertical	Pass
		1880	16.98	3.91	8.90	21.97	157.40	Vertical	Pass
		1909.3	15.60	3.93	8.90	20.57	114.02	Vertical	Pass
3.0MHz Band QPSK	15/0	1851.5	15.63	3.77	8.90	20.76	119.12	Vertical	Pass
		1880	16.40	3.91	8.90	21.39	137.72	Vertical	Pass
		1908.5	15.49	3.94	8.90	20.45	110.92	Vertical	Pass
5.0MHz Band QPSK	25/0	1852.5	16.20	3.77	8.90	21.33	135.83	Vertical	Pass
		1880	16.51	3.91	8.90	21.5	141.25	Vertical	Pass
		1907.5	17.02	3.94	8.90	21.98	157.76	Vertical	Pass
10.0MHz Band QPSK	50/0	1855	16.48	3.79	8.90	21.59	144.21	Vertical	Pass
		1880	16.07	3.95	8.90	21.02	126.47	Vertical	Pass
		1905	16.24	3.97	8.90	21.17	130.92	Vertical	Pass
15.0MHz Band QPSK	75/0	1857.5	17.18	3.79	8.90	22.29	169.43	Vertical	Pass
		1880	16.77	3.95	8.90	21.72	148.59	Vertical	Pass
		1902.5	18.74	3.97	8.90	23.67	232.81	Vertical	Pass
20.0MHz	100/0	1860	18.59	3.81	8.90	23.68	233.35	Vertical	Pass

Band QPSK	1880	17.39	3.96	8.90	22.33	171.00	Vertical	Pass
	1900	18.19	4.00	8.90	23.09	203.70	Vertical	Pass

Note:

SG Level= Signal generator output

Max. EIRP Average (dBm)= Antenna Gain(dB)+ SG Level (dBm)- Cable Loss(dBm)

Factor Gain(dB)=Antenna Gain(dB) + Amplifier Factor (dB)

Radiated Power (EIRP) for Band 2									
Mode	RB/RB SIZE	Frequency	Result					Polarization Of Max. ERP	Conclusion
			SG Level (dBm)	Cable Loss (dBm)	Factor Gain (dB)	Max. EIRP Average (dBm)	Max. EIRP Average (mW)		
1.4MHz Band 16 QAM	6/0	1850.7	14.60	3.76	8.90	20.53	112.98	Horizontal	Pass
		1880	15.75	3.91	8.90	22.39	173.38	Horizontal	Pass
		1909.3	15.45	3.93	8.90	22.12	162.93	Horizontal	Pass
3.0MHz Band 16 QAM	15/0	1851.5	15.29	3.77	8.90	20.32	107.65	Horizontal	Pass
		1880	14.95	3.91	8.90	20.88	122.46	Horizontal	Pass
		1908.5	14.55	3.94	8.90	21.58	143.88	Horizontal	Pass
5.0MHz Band 16 QAM	25/0	1852.5	15.14	3.77	8.90	22.15	164.06	Horizontal	Pass
		1880	15.50	3.91	8.90	21.03	126.77	Horizontal	Pass
		1907.5	14.00	3.94	8.90	20.81	120.50	Horizontal	Pass
10.0MHz Band 16 QAM	50/0	1855	15.35	3.79	8.90	21.43	139.00	Horizontal	Pass
		1880	14.05	3.95	8.90	20.29	106.91	Horizontal	Pass
		1905	15.36	3.97	8.90	23.12	205.12	Horizontal	Pass
15.0MHz Band 16 QAM	75/0	1857.5	13.68	3.79	8.90	22.43	174.98	Horizontal	Pass
		1880	15.77	3.95	8.90	20.96	124.74	Horizontal	Pass
		1902.5	15.65	3.97	8.90	22.02	159.22	Horizontal	Pass
20.0MHz Band 16 QAM	100/0	1860	13.84	3.81	8.90	21.86	153.46	Horizontal	Pass
		1880	16.17	3.96	8.90	21.96	157.04	Horizontal	Pass
		1900	14.55	4.00	8.90	20.86	121.90	Horizontal	Pass
1.4MHz Band 16 QAM	6/0	1850.7	14.61	3.76	8.90	21.66	146.55	Vertical	Pass
		1880	15.84	3.91	8.90	20.22	105.20	Vertical	Pass
		1909.3	15.13	3.93	8.90	22.71	186.64	Vertical	Pass
3.0MHz Band 16 QAM	15/0	1851.5	13.77	3.77	8.90	21.53	142.23	Vertical	Pass
		1880	14.83	3.91	8.90	22.94	196.79	Vertical	Pass
		1908.5	14.56	3.94	8.90	21.64	145.88	Vertical	Pass
5.0MHz Band 16 QAM	25/0	1852.5	13.76	3.77	8.90	22.63	183.23	Vertical	Pass
		1880	15.05	3.91	8.90	21.45	139.64	Vertical	Pass
		1907.5	15.69	3.94	8.90	21.56	143.22	Vertical	Pass
10.0MHz Band 16 QAM	50/0	1855	13.98	3.79	8.90	21.89	154.53	Vertical	Pass
		1880	15.57	3.95	8.90	20.34	108.14	Vertical	Pass
		1905	15.12	3.97	8.90	22.19	165.58	Vertical	Pass
15.0MHz Band 16 QAM	75/0	1857.5	13.85	3.79	8.90	20.42	110.15	Vertical	Pass
		1880	14.87	3.95	8.90	22.87	193.64	Vertical	Pass
		1902.5	13.66	3.97	8.90	22.00	158.49	Vertical	Pass
20.0MHz Band 16	100/0	1860	14.29	3.81	8.90	21.56	143.22	Vertical	Pass
		1880	14.90	3.96	8.90	23.53	225.42	Vertical	Pass

QAM		1900	13.78	4.00	8.90	21.00	125.89	Vertical	Pass
-----	--	------	-------	------	------	-------	--------	----------	------

Note:

SG Level= Signal generator output

Max. EIRP Average (dBm)= Antenna Gain(dB)+ SG Level (dBm)- Cable Loss(dBm)

Factor Gain(dB)=Antenna Gain(dB) + Amplifier Factor (dB)

8.3 LTE BAND 4

Radiated Power (EIRP) for Band 4									
Mode	RB/RB SIZE	Frequency	Result						Conclusion
			SG Level (dBm)	Cable Loss (dBm)	Antenna Gain (dB)	Max. EIRP Average (dBm)	Max. EIRP Average (mW)	Polarization Of Max. ERP	
1.4MHz Band QPSK	6/0	1710.7	17.02	3.12	8.90	22.80	190.55	Horizontal	Pass
		1732.5	15.38	3.27	8.90	21.01	126.18	Horizontal	Pass
		1754.3	15.78	3.29	8.90	21.39	137.72	Horizontal	Pass
3.0MHz Band QPSK	15/0	1711.5	17.00	3.13	8.90	22.77	189.23	Horizontal	Pass
		1732.5	16.29	3.27	8.90	21.92	155.60	Horizontal	Pass
		1753.5	17.14	3.30	8.90	22.74	187.93	Horizontal	Pass
5.0MHz Band QPSK	25/0	1712.5	17.34	3.13	8.90	23.11	204.64	Horizontal	Pass
		1732.5	17.58	3.27	8.90	23.21	209.41	Horizontal	Pass
		1752.5	16.21	3.30	8.90	21.81	151.71	Horizontal	Pass
10.0MHz Band QPSK	50/0	1715	16.71	3.15	8.90	22.46	176.20	Horizontal	Pass
		1732.5	16.90	3.31	8.90	22.49	177.42	Horizontal	Pass
		1750	16.64	3.33	8.90	22.21	166.34	Horizontal	Pass
15.0MHz Band QPSK	75/0	1717.5	15.55	3.15	8.90	21.30	134.90	Horizontal	Pass
		1732.5	16.93	3.31	8.90	22.52	178.65	Horizontal	Pass
		1747.5	15.79	3.33	8.90	21.36	136.77	Horizontal	Pass
20.0MHz Band QPSK	100/0	1720	14.54	3.17	8.90	20.27	106.41	Horizontal	Pass
		1732.5	16.58	3.32	8.90	22.16	164.44	Horizontal	Pass
		1745	15.90	3.36	8.90	21.44	139.32	Horizontal	Pass
1.4MHz Band QPSK	6/0	1710.7	16.20	3.12	8.90	21.98	157.76	Vertical	Pass
		1732.5	16.87	3.27	8.90	22.50	177.83	Vertical	Pass
		1754.3	16.53	3.29	8.90	22.14	163.68	Vertical	Pass
3.0MHz Band QPSK	15/0	1711.5	16.66	3.13	8.90	22.43	174.98	Vertical	Pass
		1732.5	17.17	3.27	8.90	22.80	190.55	Vertical	Pass
		1753.5	17.34	3.30	8.90	22.94	196.79	Vertical	Pass
5.0MHz Band QPSK	25/0	1712.5	16.32	3.13	8.90	22.09	161.81	Vertical	Pass
		1732.5	15.65	3.27	8.90	21.28	134.28	Vertical	Pass
		1752.5	17.20	3.30	8.90	22.80	190.55	Vertical	Pass
10.0MHz Band QPSK	50/0	1715	15.69	3.15	8.90	21.44	139.32	Vertical	Pass
		1732.5	17.52	3.31	8.90	23.11	204.64	Vertical	Pass
		1750	16.41	3.33	8.90	21.98	157.76	Vertical	Pass
15.0MHz Band QPSK	75/0	1717.5	16.85	3.15	8.90	22.60	181.97	Vertical	Pass
		1732.5	16.59	3.31	8.90	22.18	165.20	Vertical	Pass
		1747.5	15.72	3.33	8.90	21.29	134.59	Vertical	Pass
20.0MHz Band	100/0	1720	17.59	3.17	8.90	23.32	214.78	Vertical	Pass
		1732.5	18.24	3.32	8.90	23.82	240.99	Vertical	Pass



QPSK		1745	16.71	3.36	8.90	22.25	167.880	Vertical	Pass
------	--	------	-------	------	------	-------	---------	----------	------

Note:

SG Level= Signal generator output

Max. EIRP Average (dBm)= Antenna Gain(dB)+ SG Level (dBm)- Cable Loss(dBm)

Factor Gain(dB)=Antenna Gain(dB) + Amplifier Factor (dB)

Radiated Power (EIRP) for Band 4									
Mode	RB/RB SIZE	Frequency	Result						Conclusion
			SG Level (dBm)	Cable Loss (dBm)	Antenna Gain (dB)	Max. EIRP Average (dBm)	Max. EIRP Average (mW)	Polarization Of Max. ERP	
1.4MHz Band 16 QAM	6/0	1710.7	16.88	3.12	8.90	22.66	184.50	Horizontal	Pass
		1732.5	16.92	3.27	8.90	22.55	179.89	Horizontal	Pass
		1754.3	17.31	3.29	8.90	22.92	195.88	Horizontal	Pass
3.0MHz Band 16 QAM	15/0	1711.5	17.09	3.13	8.90	22.86	193.20	Horizontal	Pass
		1732.5	16.60	3.27	8.90	22.23	167.11	Horizontal	Pass
		1753.5	17.71	3.30	8.90	23.31	214.29	Horizontal	Pass
5.0MHz Band 16 QAM	25/0	1712.5	17.15	3.13	8.90	22.92	195.88	Horizontal	Pass
		1732.5	15.81	3.27	8.90	21.44	139.32	Horizontal	Pass
		1752.5	16.57	3.30	8.90	22.17	164.82	Horizontal	Pass
10.0MHz Band 16 QAM	50/0	1715	16.52	3.15	8.90	22.27	168.66	Horizontal	Pass
		1732.5	16.42	3.31	8.90	22.01	158.85	Horizontal	Pass
		1750	16.15	3.33	8.90	21.72	148.59	Horizontal	Pass
15.0MHz Band 16 QAM	75/0	1717.5	16.80	3.15	8.90	22.55	179.89	Horizontal	Pass
		1732.5	17.40	3.31	8.90	22.99	199.07	Horizontal	Pass
		1747.5	15.83	3.33	8.90	21.40	138.04	Horizontal	Pass
20.0MHz Band 16 QAM	100/0	1720	17.55	3.17	8.90	23.28	212.81	Horizontal	Pass
		1732.5	16.69	3.32	8.90	22.27	168.66	Horizontal	Pass
		1745	16.41	3.36	8.90	21.95	156.68	Horizontal	Pass
1.4MHz Band 16 QAM	6/0	1710.7	16.73	3.12	8.90	22.51	178.24	Vertical	Pass
		1732.5	17.42	3.27	8.90	23.05	201.84	Vertical	Pass
		1754.3	16.64	3.29	8.90	22.25	167.88	Vertical	Pass
3.0MHz Band 16 QAM	15/0	1711.5	15.95	3.13	8.90	21.72	148.59	Vertical	Pass
		1732.5	17.15	3.27	8.90	22.78	189.67	Vertical	Pass
		1753.5	17.38	3.30	8.90	22.98	198.61	Vertical	Pass
5.0MHz Band 16 QAM	25/0	1712.5	16.66	3.13	8.90	22.43	174.98	Vertical	Pass
		1732.5	17.18	3.27	8.90	22.81	190.99	Vertical	Pass
		1752.5	16.44	3.30	8.90	22.04	159.96	Vertical	Pass
10.0MHz Band 16 QAM	50/0	1715	17.15	3.15	8.90	22.90	194.98	Vertical	Pass
		1732.5	17.62	3.31	8.90	23.21	209.41	Vertical	Pass
		1750	16.53	3.33	8.90	22.10	162.18	Vertical	Pass
15.0MHz Band 16 QAM	75/0	1717.5	17.23	3.15	8.90	22.98	198.61	Vertical	Pass
		1732.5	17.78	3.31	8.90	23.37	217.27	Vertical	Pass
		1747.5	17.09	3.33	8.90	22.66	184.50	Vertical	Pass
20.0MHz Band 16	100/0	1720	16.60	3.17	8.90	22.33	171.00	Vertical	Pass
		1732.5	17.99	3.32	8.90	23.57	227.51	Vertical	Pass

QAM		1745	17.56	3.36	8.90	23.10	204.174	Vertical	Pass
-----	--	------	-------	------	------	-------	---------	----------	------

Note:

SG Level= Signal generator output

Max. EIRP Average (dBm)= Antenna Gain(dB)+ SG Level (dBm)- Cable Loss(dBm)

Factor Gain(dB)=Antenna Gain(dB) + Amplifier Factor (dB)

8.4 LTE BAND 5

Radiated Power (ERP) for Band 5										
Mode	RB/RB SIZE	Frequency	Result							Conclusion
			SG Level (dBm)	Cable Loss (dBm)	Antenna Gain (dB)	Correction (dB)	Max. EIRP Average (dBm)	Max. EIRP Average (mW)	Polarization Of Max. ERP	
1.4MHz Band QPSK	6/0	824.7	21.80	2.01	5.30	2.15	22.94	196.79	Horizontal	Pass
		836.5	20.36	2.01	5.30	2.15	21.50	141.25	Horizontal	Pass
		848.3	21.08	2.02	5.70	2.15	22.61	182.39	Horizontal	Pass
3.0MHz Band QPSK	15/0	825.5	19.56	2.01	5.30	2.15	20.70	117.49	Horizontal	Pass
		836.5	20.92	2.01	5.30	2.15	22.06	160.69	Horizontal	Pass
		847.5	20.15	2.02	5.70	2.15	21.68	147.23	Horizontal	Pass
5.0MHz Band QPSK	25/0	826.5	20.39	2.01	5.30	2.15	21.53	142.23	Horizontal	Pass
		836.5	20.64	2.01	5.30	2.15	21.78	150.66	Horizontal	Pass
		846.5	20.94	2.02	5.70	2.15	22.47	176.60	Horizontal	Pass
10.0MHz Band QPSK	50/0	829	20.94	2.01	5.30	2.15	22.08	161.44	Horizontal	Pass
		836.5	21.48	2.01	5.30	2.15	22.62	182.81	Horizontal	Pass
		844	19.62	2.02	5.70	2.15	21.15	130.32	Horizontal	Pass
1.4MHz Band QPSK	6/0	824.7	22.07	2.01	5.30	2.15	23.21	209.41	Vertical	Pass
		836.5	21.39	2.01	5.30	2.15	22.53	179.06	Vertical	Pass
		848.3	20.92	2.02	5.70	2.15	22.45	175.79	Vertical	Pass
3.0MHz Band QPSK	15/0	825.5	20.95	2.01	5.30	2.15	22.09	161.81	Vertical	Pass
		836.5	21.45	2.01	5.30	2.15	22.59	181.55	Vertical	Pass
		847.5	20.46	2.02	5.70	2.15	21.99	158.12	Vertical	Pass
5.0MHz Band QPSK	25/0	826.5	20.64	2.01	5.30	2.15	21.78	150.66	Vertical	Pass
		836.5	21.14	2.01	5.30	2.15	22.28	169.04	Vertical	Pass
		846.5	19.31	2.02	5.70	2.15	20.84	121.34	Vertical	Pass
10.0MHz Band QPSK	50/0	829	19.88	2.01	5.30	2.15	21.02	126.47	Vertical	Pass
		836.5	22.20	2.01	5.30	2.15	23.34	215.77	Vertical	Pass
		844	20.93	2.02	5.70	2.15	22.46	176.20	Vertical	Pass

Note:

SG Level= Signal generator output

Max. EIRP Average (dBm)= Antenna Gain(dB)+ SG Level (dBm)- Cable Loss(dBm)

Factor Gain(dB)=Antenna Gain(dB) + Amplifier Factor (dB)

Radiated Power (ERP) for Band 5										
Mode	RB/RB SIZE	Frequency	Result							Conclusion
			SG Level (dBm)	Cable Loss (dBm)	Antenna Gain (dB)	Correction (dB)	Max. EIRP Average (dBm)	Max. EIRP Average (mW)	Polarization Of Max. ERP	
1.4MHz Band 16 QAM	6/0	824.7	20.75	2.01	5.30	2.15	21.89	154.53	Horizontal	Pass
		836.5	19.91	2.01	5.30	2.15	21.05	127.35	Horizontal	Pass
		848.3	19.30	2.02	5.70	2.15	20.83	121.06	Horizontal	Pass
3.0MHz Band 16 QAM	15/0	825.5	20.70	2.01	5.30	2.15	21.84	152.76	Horizontal	Pass
		836.5	19.92	2.01	5.30	2.15	21.06	127.64	Horizontal	Pass
		847.5	19.09	2.02	5.70	2.15	20.62	115.35	Horizontal	Pass
5.0MHz Band 16 QAM	25/0	826.5	19.73	2.01	5.30	2.15	20.87	122.18	Horizontal	Pass
		836.5	19.61	2.01	5.30	2.15	20.75	118.85	Horizontal	Pass
		846.5	20.67	2.02	5.70	2.15	22.20	165.96	Horizontal	Pass
10.0MHz z Band 16 QAM	50/0	829	20.73	2.01	5.30	2.15	21.87	153.82	Horizontal	Pass
		836.5	20.75	2.01	5.30	2.15	21.89	154.53	Horizontal	Pass
		844	19.16	2.02	5.70	2.15	20.69	117.22	Horizontal	Pass
1.4MHz Band 16 QAM	6/0	824.7	20.40	2.01	5.30	2.15	21.54	142.56	Vertical	Pass
		836.5	19.98	2.01	5.30	2.15	21.12	129.42	Vertical	Pass
		848.3	20.47	2.02	5.70	2.15	22.00	158.49	Vertical	Pass
3.0MHz Band 16 QAM	15/0	825.5	19.52	2.01	5.30	2.15	20.66	116.41	Vertical	Pass
		836.5	20.26	2.01	5.30	2.15	21.40	138.04	Vertical	Pass
		847.5	20.56	2.02	5.70	2.15	22.09	161.81	Vertical	Pass
5.0MHz Band 16 QAM	25/0	826.5	20.35	2.01	5.30	2.15	21.49	140.93	Vertical	Pass
		836.5	20.39	2.01	5.30	2.15	21.53	142.23	Vertical	Pass
		846.5	19.58	2.02	5.70	2.15	21.11	129.12	Vertical	Pass
10.0MHz z Band 16 QAM	50/0	829	20.61	2.01	5.30	2.15	21.75	149.62	Vertical	Pass
		836.5	20.00	2.01	5.30	2.15	21.14	130.02	Vertical	Pass
		844	21.17	2.02	5.70	2.15	22.70	186.21	Vertical	Pass

Note:

SG Level= Signal generator output

Max. EIRP Average (dBm)= Antenna Gain(dB)+ SG Level (dBm)- Cable Loss(dBm)

Factor Gain(dB)=Antenna Gain(dB) + Amplifier Factor (dB)

8.5 LTE BAND 7

Radiated Power (EIRP) for Band 7									
Mode	RB/RB SIZE	Frequency	Result					Polarization Of Max. ERP	Conclusion
			SG Level (dBm)	Cable Loss (dBm)	Antenna Gain (dB)	Max. EIRP Average (dBm)	Max. EIRP Average (mW)		
5.0MHz Band QPSK	25/0	2502.5	17.77	4.54	9.00	22.23	167.11	Horizontal	Pass
		2535	17.60	4.69	9.00	21.91	155.24	Horizontal	Pass
		2567.5	16.02	4.71	9.00	20.31	107.40	Horizontal	Pass
10.0MHz Band QPSK	50/0	2505	17.18	4.55	9.00	21.63	145.55	Horizontal	Pass
		2535	17.01	4.69	9.00	21.32	135.52	Horizontal	Pass
		2565	19.06	4.72	9.00	23.34	215.77	Horizontal	Pass
15.0MHz Band QPSK	75/0	2507.5	18.61	4.55	9.00	23.06	202.30	Horizontal	Pass
		2535	17.82	4.69	9.00	22.13	163.31	Horizontal	Pass
		2562.5	17.50	4.72	9.00	21.78	150.66	Horizontal	Pass
20.0MHz Band QPSK	100/0	2510	16.67	4.57	9.00	21.10	128.82	Horizontal	Pass
		2535	17.74	4.73	9.00	22.01	158.85	Horizontal	Pass
		2560	17.73	4.75	9.00	21.98	157.76	Horizontal	Pass
5.0MHz Band QPSK	25/0	2502.5	17.92	4.54	9.00	22.38	172.98	Vertical	Pass
		2535	18.71	4.69	9.00	23.02	200.45	Vertical	Pass
		2567.5	17.43	4.71	9.00	21.72	148.59	Vertical	Pass
10.0MHz Band QPSK	50/0	2505	17.16	4.55	9.00	21.61	144.88	Vertical	Pass
		2535	18.71	4.69	9.00	23.02	200.45	Vertical	Pass
		2565	18.17	4.72	9.00	22.45	175.79	Vertical	Pass
15.0MHz Band QPSK	75/0	2507.5	18.89	4.55	9.00	23.34	215.77	Vertical	Pass
		2535	18.19	4.69	9.00	22.50	177.83	Vertical	Pass
		2562.5	18.89	4.72	9.00	23.17	207.49	Vertical	Pass
20.0MHz Band QPSK	100/0	2510	19.04	4.57	9.00	23.47	222.33	Vertical	Pass
		2535	18.67	4.73	9.00	22.94	196.79	Vertical	Pass
		2560	19.09	4.75	9.00	23.34	215.77	Vertical	Pass

Note:

SG Level= Signal generator output

Max. EIRP Average (dBm)= Antenna Gain(dB)+ SG Level (dBm)- Cable Loss(dBm)

Factor Gain(dB)=Antenna Gain(dB) + Amplifier Factor (dB)

Radiated Power (EIRP) for Band 7									
Mode	RB/RB SIZE	Frequency	Result					Polarization Of Max. ERP	Conclusion
			SG Level (dBm)	Cable Loss (dBm)	Antenna Gain (dB)	Max. EIRP Average (dBm)	Max. EIRP Average (mW)		
5.0MHz Band 16 QAM	25/0	2502.5	16.59	4.54	9.00	21.05	127.35	Horizontal	Pass
		2535	17.05	4.69	9.00	21.36	136.77	Horizontal	Pass
		2567.5	17.52	4.71	9.00	21.81	151.71	Horizontal	Pass
10.0MHz Band 16 QAM	50/0	2505	17.44	4.55	9.00	21.89	154.53	Horizontal	Pass
		2535	17.61	4.69	9.00	21.92	155.60	Horizontal	Pass
		2565	17.74	4.72	9.00	22.02	159.22	Horizontal	Pass
15.0MHz Band 16 QAM	75/0	2507.5	18.31	4.55	9.00	22.76	188.80	Horizontal	Pass
		2535	17.97	4.69	9.00	22.28	169.04	Horizontal	Pass
		2562.5	17.80	4.72	9.00	22.08	161.44	Horizontal	Pass
20.0MHz Band 16 QAM	100/0	2510	18.23	4.57	9.00	22.66	184.50	Horizontal	Pass
		2535	16.28	4.73	9.00	20.55	113.50	Horizontal	Pass
		2560	18.54	4.75	9.00	22.79	190.11	Horizontal	Pass
5.0MHz Band 16 QAM	25/0	2502.5	16.71	4.54	9.00	21.17	130.92	Vertical	Pass
		2535	17.18	4.69	9.00	21.49	140.93	Vertical	Pass
		2567.5	17.70	4.71	9.00	21.99	158.12	Vertical	Pass
10.0MHz Band 16 QAM	50/0	2505	18.01	4.55	9.00	22.46	176.20	Vertical	Pass
		2535	18.41	4.69	9.00	22.72	187.07	Vertical	Pass
		2565	17.07	4.72	9.00	21.35	136.46	Vertical	Pass
15.0MHz Band 16 QAM	75/0	2507.5	18.65	4.55	9.00	23.10	204.17	Vertical	Pass
		2535	17.51	4.69	9.00	21.82	152.05	Vertical	Pass
		2562.5	16.62	4.72	9.00	20.90	123.03	Vertical	Pass
20.0MHz Band 16 QAM	100/0	2510	18.72	4.57	9.00	23.15	206.54	Vertical	Pass
		2535	18.99	4.73	9.00	23.26	211.84	Vertical	Pass
		2560	18.92	4.75	9.00	23.17	207.49	Vertical	Pass

Note:

SG Level= Signal generator output

Max. EIRP Average (dBm)= Antenna Gain(dB)+ SG Level (dBm)- Cable Loss(dBm)

Factor Gain(dB)=Antenna Gain(dB) + Amplifier Factor (dB)

8.6 LTE BAND 12

Radiated Power (ERP) for Band 12										
Mode	RB/RB SIZE	Frequency	Result							Conclusion
			SG Level (dBm)	Cable Loss (dBm)	Antenna Gain (dB)	Correction (dB)	Max. EIRP Average (dBm)	Max. EIRP Average (mW)	Polarization Of Max. ERP	
1.4MHz Band QPSK	6/0	699.7	20.64	1.91	5.60	2.15	22.18	165.20	Horizontal	Pass
		707.5	20.58	1.91	5.70	2.15	22.22	166.72	Horizontal	Pass
		715.3	20.65	1.93	5.80	2.15	22.37	172.58	Horizontal	Pass
3.0MHz Band QPSK	15/0	700.5	19.30	1.91	5.60	2.15	20.84	121.34	Horizontal	Pass
		707.5	20.65	1.91	5.70	2.15	22.29	169.43	Horizontal	Pass
		714.5	20.80	1.93	5.80	2.15	22.52	178.65	Horizontal	Pass
5.0MHz Band QPSK	25/0	701.5	19.90	1.91	5.60	2.15	21.44	139.32	Horizontal	Pass
		707.5	20.70	1.91	5.70	2.15	22.34	171.40	Horizontal	Pass
		713.5	20.92	1.92	5.80	2.15	22.65	184.08	Horizontal	Pass
10.0MHz Band QPSK	50/0	704	21.32	1.91	5.60	2.15	22.86	193.20	Horizontal	Pass
		707.5	20.31	1.91	5.70	2.15	21.95	156.68	Horizontal	Pass
		711	20.13	1.92	5.80	2.15	21.86	153.46	Horizontal	Pass
1.4MHz Band QPSK	6/0	699.7	19.82	1.91	5.60	2.15	21.36	136.77	Vertical	Pass
		707.5	20.51	1.91	5.70	2.15	22.15	164.06	Vertical	Pass
		715.3	18.95	1.93	5.80	2.15	20.67	116.68	Vertical	Pass
3.0MHz Band QPSK	15/0	700.5	20.05	1.91	5.60	2.15	21.59	144.21	Vertical	Pass
		707.5	20.48	1.91	5.70	2.15	22.12	162.93	Vertical	Pass
		714.5	20.23	1.93	5.80	2.15	21.95	156.68	Vertical	Pass
5.0MHz Band QPSK	25/0	701.5	19.22	1.91	5.60	2.15	20.76	119.12	Vertical	Pass
		707.5	20.05	1.91	5.70	2.15	21.69	147.57	Vertical	Pass
		713.5	19.40	1.92	5.80	2.15	21.13	129.72	Vertical	Pass
10.0MHz Band QPSK	50/0	704	20.57	1.91	5.60	2.15	22.11	162.55	Vertical	Pass
		707.5	20.61	1.91	5.70	2.15	22.25	167.88	Vertical	Pass
		711	21.95	1.92	5.80	2.15	23.68	233.35	Vertical	Pass



Radiated Power (ERP) for Band 12										
Mode	RB/R B SIZE	Frequency	Result							Conclusion
			SG Level (dBm)	Cable Loss (dBm)	Antenna Gain (dB)	Correction (dB)	Max. EIRP Average (dBm)	Max. EIRP Average (mW)	Polarization Of Max. ERP	
1.4MHz Band 16 QAM	6/0	699.7	18.47	1.91	5.60	2.15	20.01	100.23	Horizontal	Pass
		707.5	20.06	1.91	5.70	2.15	21.70	147.91	Horizontal	Pass
		715.3	18.59	1.93	5.80	2.15	20.31	107.40	Horizontal	Pass
3.0MHz Band 16 QAM	15/0	700.5	21.22	1.91	5.60	2.15	22.76	188.80	Horizontal	Pass
		707.5	18.93	1.91	5.70	2.15	20.57	114.02	Horizontal	Pass
		714.5	19.03	1.93	5.80	2.15	20.75	118.85	Horizontal	Pass
5.0MHz Band 16 QAM	25/0	701.5	19.26	1.91	5.60	2.15	20.80	120.23	Horizontal	Pass
		707.5	20.80	1.91	5.70	2.15	22.44	175.39	Horizontal	Pass
		713.5	20.59	1.92	5.80	2.15	22.32	170.61	Horizontal	Pass
10.0MHz Band 16 QAM	50/0	704	20.36	1.91	5.60	2.15	21.90	154.88	Horizontal	Pass
		707.5	19.04	1.91	5.70	2.15	20.68	116.95	Horizontal	Pass
		711	20.42	1.92	5.80	2.15	22.15	164.06	Horizontal	Pass
1.4MHz Band 16 QAM	6/0	699.7	20.54	1.91	5.60	2.15	22.08	161.44	Vertical	Pass
		707.5	20.65	1.91	5.70	2.15	22.29	169.43	Vertical	Pass
		715.3	20.19	1.93	5.80	2.15	21.91	155.24	Vertical	Pass
3.0MHz Band 16 QAM	15/0	700.5	20.18	1.91	5.60	2.15	21.72	148.59	Vertical	Pass
		707.5	19.16	1.91	5.70	2.15	20.80	120.23	Vertical	Pass
		714.5	19.69	1.93	5.80	2.15	21.41	138.36	Vertical	Pass
5.0MHz Band 16 QAM	25/0	701.5	19.25	1.91	5.60	2.15	20.79	119.95	Vertical	Pass
		707.5	19.73	1.91	5.70	2.15	21.37	137.09	Vertical	Pass
		713.5	19.86	1.92	5.80	2.15	21.59	144.21	Vertical	Pass
10.0MHz Band 16 QAM	50/0	704	19.00	1.91	5.60	2.15	20.54	113.24	Vertical	Pass
		707.5	21.47	1.91	5.70	2.15	23.11	204.64	Vertical	Pass
		711	20.24	1.92	5.80	2.15	21.97	157.40	Vertical	Pass

Note:

SG Level= Signal generator output

Max. EIRP Average (dBm)= Antenna Gain(dB)+ SG Level (dBm)- Cable Loss(dBm)

Factor Gain(dB)=Antenna Gain(dB) + Amplifier Factor (dB)

8.7 LTE BAND 17

Radiated Power (ERP) for Band 17										
Mode	RB/RB SIZE	Frequency	Result							Conclusion
			SG Level (dBm)	Cable Loss (dBm)	Factor Gain (dB)	Correction (dB)	Max. ERP Average (dBm)	Max. ERP Average (mW)	Polarization Of Max. ERP	
5.0MHz Band QPSK	25/0	706.5	20.18	1.91	5.60	2.15	21.72	148.59	Vertical	Pass
		710	20.34	1.91	5.70	2.15	21.98	157.76	Vertical	Pass
		713.5	21.14	1.92	5.80	2.15	22.87	193.64	Vertical	Pass
10.0MHz Band QPSK	50/0	709	20.33	1.91	5.60	2.15	21.87	153.82	Vertical	Pass
		710	20.62	1.91	5.70	2.15	22.26	168.27	Vertical	Pass
		711	18.25	1.92	5.80	2.15	19.98	99.54	Vertical	Pass
5.0MHz Band QPSK	25/0	706.5	18.64	1.91	5.60	2.15	20.18	104.23	Horizontal	Pass
		710	19.85	1.91	5.70	2.15	21.49	140.93	Horizontal	Pass
		713.5	20.70	1.92	5.80	2.15	22.43	174.98	Horizontal	Pass
10.0MHz Band QPSK	50/0	709	22.30	1.91	5.60	2.15	23.84	242.10	Horizontal	Pass
		710	22.03	1.91	5.70	2.15	23.67	232.81	Horizontal	Pass
		711	20.53	1.92	5.80	2.15	22.26	168.27	Horizontal	Pass

Radiated Power (ERP) for Band 17										
Mode	RB/RB SIZE	Frequency	Result							Conclusion
			SG Level (dBm)	Cable Loss (dBm)	Factor Gain (dB)	Correction (dB)	Max. ERP Average (dBm)	Max. ERP Average (mW)	Polarization Of Max. ERP	
5.0MHz Band 16 QAM	25/0	706.5	16.81	1.91	5.6	2.15	22.36	172.19	Vertical	Pass
		710	16.39	1.91	5.7	2.15	23.19	208.45	Vertical	Pass
		713.5	17.43	1.92	5.8	2.15	22.78	189.67	Vertical	Pass
10.0MHz Band 16 QAM	50/0	709	15.91	1.91	5.6	2.15	21.70	147.91	Vertical	Pass
		710	15.84	1.91	5.7	2.15	22.18	165.20	Vertical	Pass
		711	15.59	1.92	5.8	2.15	22.13	163.31	Vertical	Pass
5.0MHz Band 16 QAM	25/0	706.5	17.52	1.91	5.6	2.15	22.31	170.22	Horizontal	Pass
		710	17.46	1.91	5.7	2.15	22.35	171.79	Horizontal	Pass
		713.5	16.25	1.92	5.8	2.15	22.75	188.36	Horizontal	Pass
10.0MHz Band 16 QAM	50/0	709	17.30	1.91	5.6	2.15	23.61	229.61	Horizontal	Pass
		710	17.57	1.91	5.7	2.15	23.26	211.84	Horizontal	Pass
		711	16.65	1.92	5.8	2.15	23.11	204.64	Horizontal	Pass

Note:

SG Level= Signal generator output

Max. EIRP Average (dBm)= Antenna Gain(dB)+ SG Level (dBm)- Cable Loss(dBm)

Factor Gain(dB)=Antenna Gain(dB) + Amplifier Factor (dB)

8.8 LTE BAND 25

Radiated Power (EIRP) for Band 25									
Mode	RB/RB SIZE	Frequency	Result						Conclusion
			SG Level (dBm)	Cable Loss (dBm)	Antenna Gain (dB)	Max. EIRP Average (dBm)	Max. EIRP Average (mW)	Polarization Of Max. ERP	
1.4MHz Band QPSK	6/0	1850.7	17.73	3.12	8.90	23.51	224.39	Horizontal	Pass
		1882.5	17.83	3.27	8.90	23.46	221.82	Horizontal	Pass
		1914.3	17.71	3.29	8.90	23.32	214.78	Horizontal	Pass
3.0MHz Band QPSK	15/0	1851.5	17.59	3.13	8.90	23.36	216.77	Horizontal	Pass
		1882.5	17.69	3.27	8.90	23.32	214.78	Horizontal	Pass
		1913.5	17.64	3.30	8.90	23.24	210.86	Horizontal	Pass
5.0MHz Band QPSK	25/0	1852.5	16.98	3.13	8.90	22.75	188.36	Horizontal	Pass
		1882.5	17.89	3.27	8.90	23.52	224.91	Horizontal	Pass
		1912.5	17.15	3.30	8.90	22.75	188.36	Horizontal	Pass
10.0MHz Band QPSK	50/0	1855	17.17	3.15	8.90	22.92	195.88	Horizontal	Pass
		1882.5	17.62	3.31	8.90	23.21	209.41	Horizontal	Pass
		1910	17.73	3.33	8.90	23.30	213.80	Horizontal	Pass
15.0MHz Band QPSK	75/0	1857.5	17.70	3.15	8.90	23.45	221.31	Horizontal	Pass
		1882.5	17.61	3.31	8.90	23.20	208.93	Horizontal	Pass
		1907.5	17.57	3.33	8.90	23.14	206.06	Horizontal	Pass
20.0MHz Band QPSK	100/0	1860	16.56	3.17	8.90	22.29	169.43	Horizontal	Pass
		1882.5	17.42	3.32	8.90	23.00	199.53	Horizontal	Pass
		1905	17.18	3.36	8.90	22.72	187.07	Horizontal	Pass
1.4MHz Band QPSK	6/0	1850.7	17.73	3.12	8.90	23.51	224.39	Vertical	Pass
		1882.5	17.30	3.27	8.90	22.93	196.34	Vertical	Pass
		1914.3	17.79	3.29	8.90	23.40	218.78	Vertical	Pass
3.0MHz Band QPSK	15/0	1851.5	17.68	3.13	8.90	23.45	221.31	Vertical	Pass
		1882.5	17.60	3.27	8.90	23.23	210.38	Vertical	Pass
		1913.5	17.60	3.30	8.90	23.20	208.93	Vertical	Pass
5.0MHz Band QPSK	25/0	1852.5	17.26	3.13	8.90	23.03	200.91	Vertical	Pass
		1882.5	17.69	3.27	8.90	23.32	214.78	Vertical	Pass
		1912.5	16.86	3.30	8.90	22.46	176.20	Vertical	Pass
10.0MHz Band QPSK	50/0	1855	16.72	3.15	8.90	22.47	176.60	Vertical	Pass
		1882.5	17.78	3.31	8.90	23.37	217.27	Vertical	Pass
		1910	17.29	3.33	8.90	22.86	193.20	Vertical	Pass
15.0MHz Band QPSK	75/0	1857.5	17.34	3.15	8.90	23.09	203.70	Vertical	Pass
		1882.5	17.29	3.31	8.90	22.88	194.09	Vertical	Pass
		1907.5	16.91	3.33	8.90	22.48	177.01	Vertical	Pass
20.0MHz	100/0	1860	16.81	3.17	8.90	22.54	179.47	Vertical	Pass

Band		1882.5	17.96	3.32	8.90	23.54	225.94	Vertical	Pass
QPSK		1905	17.64	3.36	8.90	23.18	207.97	Vertical	Pass

Radiated Power (EIRP) for Band 25									
Mode	RB/R B SIZE	Frequency	Result						Conclusion
			SG Level (dBm)	Cable Loss (dBm)	Antenna Gain (dB)	Max. EIRP Average (dBm)	Max. EIRP Average (mW)	Polarization Of Max. ERP	
1.4MHz Band 16 QAM	6/0	1850.7	16.71	3.12	8.90	22.49	177.42	Horizontal	Pass
		1882.5	17.42	3.27	8.90	23.05	201.84	Horizontal	Pass
		1914.3	17.55	3.29	8.90	23.16	207.01	Horizontal	Pass
3.0MHz Band 16 QAM	15/0	1851.5	17.10	3.13	8.90	22.87	193.64	Horizontal	Pass
		1882.5	17.41	3.27	8.90	23.04	201.37	Horizontal	Pass
		1913.5	16.89	3.30	8.90	22.49	177.42	Horizontal	Pass
5.0MHz Band 16 QAM	25/0	1852.5	17.80	3.13	8.90	23.57	227.51	Horizontal	Pass
		1882.5	16.94	3.27	8.90	22.57	180.72	Horizontal	Pass
		1912.5	17.76	3.30	8.90	23.36	216.77	Horizontal	Pass
10.0MHz Band 16 QAM	50/0	1855	17.16	3.15	8.90	22.91	195.43	Horizontal	Pass
		1882.5	17.07	3.31	8.90	22.66	184.50	Horizontal	Pass
		1910	17.00	3.33	8.90	22.57	180.72	Horizontal	Pass
15.0MHz Band 16 QAM	75/0	1857.5	17.23	3.15	8.90	22.98	198.61	Horizontal	Pass
		1882.5	17.49	3.31	8.90	23.08	203.24	Horizontal	Pass
		1907.5	17.19	3.33	8.90	22.76	188.80	Horizontal	Pass
20.0MHz Band 16 QAM	100/0	1860	17.18	3.17	8.90	22.91	195.43	Horizontal	Pass
		1882.5	16.89	3.32	8.90	22.47	176.60	Horizontal	Pass
		1905	16.79	3.36	8.90	22.33	171.00	Horizontal	Pass
1.4MHz Band 16 QAM	6/0	1850.7	17.90	3.12	8.90	23.68	233.35	Vertical	Pass
		1882.5	16.55	3.27	8.90	22.18	165.20	Vertical	Pass
		1914.3	17.14	3.29	8.90	22.75	188.36	Vertical	Pass
3.0MHz Band 16 QAM	15/0	1851.5	17.18	3.13	8.90	22.95	197.24	Vertical	Pass
		1882.5	16.50	3.27	8.90	22.13	163.31	Vertical	Pass
		1913.5	18.04	3.30	8.90	23.64	231.21	Vertical	Pass
5.0MHz Band 16 QAM	25/0	1852.5	17.18	3.13	8.90	22.95	197.24	Vertical	Pass
		1882.5	17.35	3.27	8.90	22.98	198.61	Vertical	Pass
		1912.5	17.27	3.30	8.90	22.87	193.64	Vertical	Pass
10.0MHz Band 16 QAM	50/0	1855	17.12	3.15	8.90	22.87	193.64	Vertical	Pass
		1882.5	17.16	3.31	8.90	22.75	188.36	Vertical	Pass
		1910	17.04	3.33	8.90	22.61	182.39	Vertical	Pass
15.0MHz Band 16 QAM	75/0	1857.5	16.71	3.15	8.90	22.46	176.20	Vertical	Pass
		1882.5	17.90	3.31	8.90	23.49	223.36	Vertical	Pass
		1907.5	17.74	3.33	8.90	23.31	214.29	Vertical	Pass
20.0MHz Band 16	100/0	1860	17.98	3.17	8.90	23.71	234.96	Vertical	Pass
		1882.5	18.21	3.32	8.90	23.79	239.33	Vertical	Pass

QAM		1905	17.04	3.36	8.90	22.58	181.13	Vertical	Pass
-----	--	------	-------	------	------	-------	--------	----------	------

Note:

SG Level= Signal generator output

Max. EIRP Average (dBm)= Antenna Gain(dB)+ SG Level (dBm)- Cable Loss(dBm)

Factor Gain(dB)=Antenna Gain(dB) + Amplifier Factor (dB)

8.9 LTE BAND 26

Radiated Power (ERP) for Band 26(814MHz~824MHz)										
Mode	RB/R B SIZE	Frequency	Result							Conclusi on
			SG Level (dBm)	Cable Loss (dBm)	Antenna Gain (dB)	Correction (dB)	Max. EIRP Average (dBm)	Max. EIRP Average (mW)	Polarization Of Max. ERP	
1.4MHz BW QPSK	6/0	814.7	23.54	3.76	5.60	2.15	23.23	210.38	Horizontal	Pass
		819	24.19	3.91	5.70	2.15	23.83	241.55	Horizontal	Pass
		823.3	23.34	3.93	5.80	2.15	23.06	202.30	Horizontal	Pass
3.0MHz BW QPSK	15/0	815.5	24.09	3.77	5.60	2.15	23.77	238.23	Horizontal	Pass
		819	24.22	3.91	5.70	2.15	23.86	243.22	Horizontal	Pass
		822.5	23.55	3.94	5.80	2.15	23.26	211.84	Horizontal	Pass
5.0MHz BW QPSK	25/0	816.5	23.63	3.77	5.60	2.15	23.31	214.29	Horizontal	Pass
		819	23.27	3.91	5.70	2.15	22.91	195.43	Horizontal	Pass
		821.5	24.04	3.94	5.80	2.15	23.75	237.14	Horizontal	Pass
10.0MHz BW QPSK	50/0	819	23.90	3.91	5.70	2.15	23.54	225.94	Horizontal	Pass
1.4MHz BW QPSK	6/0	814.7	23.55	3.79	5.60	2.15	23.21	209.41	Vertical	Pass
		819	23.70	3.95	5.70	2.15	23.30	213.80	Vertical	Pass
		823.3	23.47	3.97	5.80	2.15	23.15	206.54	Vertical	Pass
3.0MHz BW QPSK	15/0	815.5	23.78	3.77	5.60	2.15	23.46	221.82	Vertical	Pass
		819	23.94	3.91	5.70	2.15	23.58	228.03	Vertical	Pass
		822.5	23.79	3.94	5.80	2.15	23.50	223.87	Vertical	Pass
5.0MHz BW QPSK	25/0	816.5	23.45	3.77	5.60	2.15	23.13	205.59	Vertical	Pass
		819	23.79	3.91	5.70	2.15	23.43	220.29	Vertical	Pass
		821.5	23.96	3.94	5.80	2.15	23.67	232.81	Vertical	Pass
10.0MHz BW QPSK	50/0	819	24.24	3.91	5.70	2.15	23.88	244.34	Vertical	Pass



Radiated Power (ERP) for Band 26(814MHz~824MHz)										
Mode	RB/RB SIZE	Frequency	Result							Conclusion
			SG Level (dBm)	Cable Loss (dBm)	Antenna Gain (dB)	Correction (dB)	Max. EIRP Average (dBm)	Max. EIRP Average (mW)	Polarization Of Max. ERP	
1.4MHz BW 16 QAM	6/0	814.7	23.84	3.76	5.60	2.15	23.53	225.42	Horizontal	Pass
		819	23.61	3.91	5.70	2.15	23.25	211.35	Horizontal	Pass
		823.3	23.64	3.93	5.80	2.15	23.36	216.77	Horizontal	Pass
3.0MHz BW 16 QAM	15/0	815.5	23.42	3.77	5.60	2.15	23.10	204.17	Horizontal	Pass
		819	23.57	3.91	5.70	2.15	23.21	209.41	Horizontal	Pass
		822.5	23.11	3.94	5.80	2.15	22.82	191.43	Horizontal	Pass
5.0MHz BW 16 QAM	25/0	816.5	23.58	3.77	5.60	2.15	23.26	211.84	Horizontal	Pass
		819	23.07	3.91	5.70	2.15	22.71	186.64	Horizontal	Pass
		821.5	23.81	3.94	5.80	2.15	23.52	224.91	Horizontal	Pass
10.0MHz BW 16 QAM	50/0	819	23.41	3.91	5.70	2.15	23.05	201.84	Horizontal	Pass
1.4MHz BW 16 QAM	6/0	814.7	23.49	3.79	5.60	2.15	23.15	206.54	Vertical	Pass
		819	23.93	3.95	5.70	2.15	23.53	225.42	Vertical	Pass
		823.3	23.32	3.97	5.80	2.15	23.00	199.53	Vertical	Pass
3.0MHz BW 16 QAM	15/0	815.5	23.68	3.77	5.60	2.15	23.36	216.77	Vertical	Pass
		819	23.72	3.91	5.70	2.15	23.36	216.77	Vertical	Pass
		822.5	22.96	3.94	5.80	2.15	22.67	184.93	Vertical	Pass
5.0MHz BW 16 QAM	25/0	816.5	23.11	3.77	5.60	2.15	22.79	190.11	Vertical	Pass
		819	22.77	3.91	5.70	2.15	22.41	174.18	Vertical	Pass
		821.5	23.45	3.94	5.80	2.15	23.16	207.01	Vertical	Pass
10.0MHz BW 16 QAM	50/0	819	23.92	3.91	5.70	2.15	23.56	226.99	Vertical	Pass

8.10 LTE BAND 26

Radiated Power (ERP) for Band 26(824MHz~849MHz)										
Mode	RB/RB SIZE	Frequency	Result							Conclusion
			SG Level (dBm)	Cable Loss (dBm)	Antenna Gain (dB)	Correction (dB)	Max. EIRP Average (dBm)	Max. EIRP Average (mW)	Polarization Of Max. ERP	
1.4MHz Band QPSK	6/0	824.7	21.54	2.01	5.30	2.15	22.68	185.35	Horizontal	Pass
		836.5	20.24	2.01	5.30	2.15	21.38	137.40	Horizontal	Pass
		848.3	21.32	2.02	5.70	2.15	22.85	192.75	Horizontal	Pass
3.0MHz Band QPSK	15/0	825.5	20.43	2.01	5.30	2.15	21.57	143.55	Horizontal	Pass
		836.5	20.92	2.01	5.30	2.15	22.06	160.69	Horizontal	Pass
		847.5	20.55	2.02	5.70	2.15	22.08	161.44	Horizontal	Pass
5.0MHz Band QPSK	25/0	826.5	20.67	2.01	5.30	2.15	21.81	151.71	Horizontal	Pass
		836.5	20.25	2.01	5.30	2.15	21.39	137.72	Horizontal	Pass
		846.5	20.76	2.02	5.70	2.15	22.29	169.43	Horizontal	Pass
10.0MHz z Band QPSK	50/0	829	20.43	2.01	5.30	2.15	21.57	143.55	Horizontal	Pass
		836.5	20.41	2.01	5.30	2.15	21.55	142.89	Horizontal	Pass
		844	19.90	2.02	5.70	2.15	21.43	139.00	Horizontal	Pass
15.0MHz z Band QPSK	75/0	831.5	21.17	2.01	5.30	2.15	22.31	170.22	Horizontal	Pass
		836.5	20.46	2.01	5.30	2.15	21.60	144.54	Horizontal	Pass
		841.5	20.63	2.02	5.70	2.15	22.16	164.44	Horizontal	Pass
1.4MHz Band QPSK	6/0	824.7	22.05	2.01	5.30	2.15	23.19	208.45	Vertical	Pass
		836.5	21.44	2.01	5.30	2.15	22.58	181.13	Vertical	Pass
		848.3	20.90	2.02	5.70	2.15	22.43	174.98	Vertical	Pass
3.0MHz Band QPSK	15/0	825.5	20.94	2.01	5.30	2.15	22.08	161.44	Vertical	Pass
		836.5	21.43	2.01	5.30	2.15	22.57	180.72	Vertical	Pass
		847.5	21.09	2.02	5.70	2.15	22.62	182.81	Vertical	Pass
5.0MHz Band QPSK	25/0	826.5	21.08	2.01	5.30	2.15	22.22	166.72	Vertical	Pass
		836.5	21.28	2.01	5.30	2.15	22.42	174.58	Vertical	Pass
		846.5	20.64	2.02	5.70	2.15	22.17	164.82	Vertical	Pass
10.0MHz z Band QPSK	50/0	829	21.23	2.01	5.30	2.15	22.37	172.58	Vertical	Pass
		836.5	22.02	2.01	5.30	2.15	23.16	207.01	Vertical	Pass
		844	21.68	2.02	5.70	2.15	23.21	209.41	Vertical	Pass
15.0MHz z Band QPSK	75/0	831.5	20.71	2.01	5.30	2.15	21.85	153.11	Vertical	Pass
		836.5	22.09	2.01	5.30	2.15	23.23	210.38	Vertical	Pass
		841.5	21.16	2.02	5.70	2.15	22.69	185.78	Vertical	Pass

Radiated Power (ERP) for Band 26(824MHz~849MHz)										
Mode	RB/RB SIZE	Frequency	Result							Conclusion
			SG Level (dBm)	Cable Loss (dBm)	Antenna Gain (dB)	Correction (dB)	Max. EIRP Average (dBm)	Max. EIRP Average (mW)	Polarization Of Max. ERP	
1.4MHz Band 16 QAM	6/0	824.7	22.17	2.01	5.30	2.15	23.31	214.29	Horizontal	Pass
		836.5	21.28	2.01	5.30	2.15	22.42	174.58	Horizontal	Pass
		848.3	19.93	2.02	5.70	2.15	21.46	139.96	Horizontal	Pass
3.0MHz Band 16 QAM	15/0	825.5	19.96	2.01	5.30	2.15	21.10	128.82	Horizontal	Pass
		836.5	20.77	2.01	5.30	2.15	21.91	155.24	Horizontal	Pass
		847.5	20.39	2.02	5.70	2.15	21.92	155.60	Horizontal	Pass
5.0MHz Band 16 QAM	25/0	826.5	20.06	2.01	5.30	2.15	21.20	131.83	Horizontal	Pass
		836.5	20.77	2.01	5.30	2.15	21.91	155.24	Horizontal	Pass
		846.5	19.85	2.02	5.70	2.15	21.38	137.40	Horizontal	Pass
10.0MHz Band 16 QAM	50/0	829	20.37	2.01	5.30	2.15	21.51	141.58	Horizontal	Pass
		836.5	21.47	2.01	5.30	2.15	22.61	182.39	Horizontal	Pass
		844	20.79	2.02	5.70	2.15	22.32	170.61	Horizontal	Pass
15.0MHz Band QPSK	75/0	831.5	21.19	2.01	5.30	2.15	22.33	171.00	Horizontal	Pass
		836.5	20.48	2.01	5.30	2.15	21.62	145.21	Horizontal	Pass
		841.5	20.82	2.02	5.70	2.15	22.35	171.79	Horizontal	Pass
1.4MHz Band 16 QAM	6/0	824.7	20.68	2.01	5.30	2.15	21.82	152.05	Vertical	Pass
		836.5	22.00	2.01	5.30	2.15	23.14	206.06	Vertical	Pass
		848.3	21.47	2.02	5.70	2.15	23.00	199.53	Vertical	Pass
3.0MHz Band 16 QAM	15/0	825.5	20.21	2.01	5.30	2.15	21.35	136.46	Vertical	Pass
		836.5	20.48	2.01	5.30	2.15	21.62	145.21	Vertical	Pass
		847.5	20.46	2.02	5.70	2.15	21.99	158.12	Vertical	Pass
5.0MHz Band 16 QAM	25/0	826.5	20.62	2.01	5.30	2.15	21.76	149.97	Vertical	Pass
		836.5	20.53	2.01	5.30	2.15	21.67	146.89	Vertical	Pass
		846.5	21.32	2.02	5.70	2.15	22.85	192.75	Vertical	Pass
10.0MHz Band 16 QAM	50/0	829	22.38	2.01	5.30	2.15	23.52	224.91	Vertical	Pass
		836.5	21.13	2.01	5.30	2.15	22.27	168.66	Vertical	Pass
		844	20.40	2.02	5.70	2.15	21.93	155.96	Vertical	Pass
15.0MHz Band QPSK	75/0	831.5	21.78	2.01	5.30	2.15	22.92	195.88	Vertical	Pass
		836.5	21.70	2.01	5.30	2.15	22.84	192.31	Vertical	Pass
		841.5	22.39	2.02	5.70	2.15	23.92	246.60	Vertical	Pass

Note:

SG Level= Signal generator output

Max. EIRP Average (dBm)= Antenna Gain(dB)+ SG Level (dBm)- Cable Loss(dBm)

Factor Gain(dB)=Antenna Gain(dB) + Amplifier Factor (dB)

8.11 LTE BAND 41

Radiated Power (EIRP) for Band 41									
Mode	RB/RB SIZE	Frequency	Result					Polarization Of Max. ERP	Conclusion
			SG Level (dBm)	Cable Loss (dBm)	Antenna Gain (dB)	Max. EIRP Average (dBm)	Max. EIRP Average (mW)		
5.0MHz Band QPSK	25/0	2537.5	18.89	4.54	9.00	23.35	216.27	Horizontal	Pass
		2595	18.65	4.69	9.00	22.96	197.70	Horizontal	Pass
		2652.5	17.19	4.71	9.00	21.48	140.60	Horizontal	Pass
10.0MHz Band QPSK	50/0	2540	18.75	4.55	9.00	23.20	208.93	Horizontal	Pass
		2595	19.19	4.69	9.00	23.50	223.87	Horizontal	Pass
		2650	19.18	4.72	9.00	23.46	221.82	Horizontal	Pass
15.0MHz Band QPSK	75/0	2542.5	18.44	4.55	9.00	22.89	194.54	Horizontal	Pass
		2595	20.07	4.69	9.00	24.38	274.16	Horizontal	Pass
		2647.5	19.91	4.72	9.00	24.19	262.42	Horizontal	Pass
20.0MHz Band QPSK	100/0	2545	19.39	4.57	9.00	23.82	240.99	Horizontal	Pass
		2595	20.38	4.73	9.00	24.65	291.74	Horizontal	Pass
		2645	17.91	4.75	9.00	22.16	164.44	Horizontal	Pass
5.0MHz Band QPSK	25/0	2537.5	19.99	4.54	9.00	24.45	278.61	Vertical	Pass
		2595	18.76	4.69	9.00	23.07	202.77	Vertical	Pass
		2652.5	19.46	4.71	9.00	23.75	237.14	Vertical	Pass
10.0MHz Band QPSK	50/0	2540	18.60	4.55	9.00	23.05	201.84	Vertical	Pass
		2595	19.68	4.69	9.00	23.99	250.61	Vertical	Pass
		2650	18.83	4.72	9.00	23.11	204.64	Vertical	Pass
15.0MHz Band QPSK	75/0	2542.5	18.39	4.55	9.00	22.84	192.31	Vertical	Pass
		2595	18.93	4.69	9.00	23.24	210.86	Vertical	Pass
		2647.5	19.63	4.72	9.00	23.91	246.04	Vertical	Pass
20.0MHz Band QPSK	100/0	2545	19.80	4.57	9.00	24.23	264.85	Vertical	Pass
		2595	20.16	4.73	9.00	24.43	277.33	Vertical	Pass
		2645	20.72	4.75	9.00	24.97	314.05	Vertical	Pass

Radiated Power (EIRP) for Band 41									
Mode	RB/RB SIZE	Frequency	Result					Polarization Of Max. ERP	Conclusion
			SG Level (dBm)	Cable Loss (dBm)	Antenna Gain (dB)	Max. EIRP Average (dBm)	Max. EIRP Average (mW)		
5.0MHz Band 16 QAM	25/0	2537.5	18.70	4.54	9.00	23.16	207.01	Horizontal	Pass
		2595	17.41	4.69	9.00	21.72	148.59	Horizontal	Pass
		2652.5	18.13	4.71	9.00	22.42	174.58	Horizontal	Pass
10.0MHz Band 16 QAM	50/0	2540	19.61	4.55	9.00	24.06	254.68	Horizontal	Pass
		2595	20.07	4.69	9.00	24.38	274.16	Horizontal	Pass
		2650	19.39	4.72	9.00	23.67	232.81	Horizontal	Pass
15.0MHz Band 16 QAM	75/0	2542.5	19.62	4.55	9.00	24.07	255.27	Horizontal	Pass
		2595	18.30	4.69	9.00	22.61	182.39	Horizontal	Pass
		2647.5	19.69	4.72	9.00	23.97	249.46	Horizontal	Pass
20.0MHz Band 16 QAM	100/0	2545	19.31	4.57	9.00	23.74	236.59	Horizontal	Pass
		2595	17.27	4.73	9.00	21.54	142.56	Horizontal	Pass
		2645	20.13	4.75	9.00	24.38	274.16	Horizontal	Pass
5.0MHz Band 16 QAM	25/0	2537.5	19.09	4.54	9.00	23.55	226.46	Vertical	Pass
		2595	18.65	4.69	9.00	22.96	197.70	Vertical	Pass
		2652.5	18.47	4.71	9.00	22.76	188.80	Vertical	Pass
10.0MHz Band 16 QAM	50/0	2540	19.82	4.55	9.00	24.27	267.30	Vertical	Pass
		2595	20.34	4.69	9.00	24.65	291.74	Vertical	Pass
		2650	18.36	4.72	9.00	22.64	183.65	Vertical	Pass
15.0MHz Band 16 QAM	75/0	2542.5	20.30	4.55	9.00	24.75	298.54	Vertical	Pass
		2595	18.51	4.69	9.00	22.82	191.43	Vertical	Pass
		2647.5	19.01	4.72	9.00	23.29	213.30	Vertical	Pass
20.0MHz Band 16 QAM	100/0	2545	20.48	4.57	9.00	24.91	309.74	Vertical	Pass
		2595	19.62	4.73	9.00	23.89	244.91	Vertical	Pass
		2645	19.63	4.75	9.00	23.88	244.34	Vertical	Pass

Note:

SG Level= Signal generator output

Max. EIRP Average (dBm)= Antenna Gain(dB)+ SG Level (dBm)- Cable Loss(dBm)

Factor Gain(dB)=Antenna Gain(dB) + Amplifier Factor (dB)

8.12 LTE BAND 66

Radiated Power (EIRP) for Band 66									
Mode	RB/RB SIZE	Frequency	Result					Polarization Of Max. ERP	Conclusion
			SG Level (dBm)	Cable Loss (dBm)	Antenna Gain (dB)	Max. EIRP Average (dBm)	Max. EIRP Average (mW)		
1.4MHz Band QPSK	6/0	1710.7	17.27	3.76	8.90	22.41	174.18	Horizontal	Pass
		1745	17.51	3.91	8.90	22.50	177.83	Horizontal	Pass
		1779.3	16.53	3.93	8.90	21.50	141.25	Horizontal	Pass
3.0MHz Band QPSK	15/0	1711.5	15.26	3.77	8.90	20.39	109.40	Horizontal	Pass
		1745	17.33	3.91	8.90	22.32	170.61	Horizontal	Pass
		1778.5	17.46	3.94	8.90	22.42	174.58	Horizontal	Pass
5.0MHz Band QPSK	25/0	1712.5	16.20	3.77	8.90	21.33	135.83	Horizontal	Pass
		1745	16.58	3.91	8.90	21.57	143.55	Horizontal	Pass
		1777.5	17.21	3.94	8.90	22.17	164.82	Horizontal	Pass
10.0MHz Band QPSK	50/0	1715	16.58	3.79	8.90	21.69	147.57	Horizontal	Pass
		1745	17.44	3.95	8.90	22.39	173.38	Horizontal	Pass
		1775	16.64	3.97	8.90	21.57	143.55	Horizontal	Pass
15.0MHz Band QPSK	75/0	1717.5	17.44	3.79	8.90	22.55	179.89	Horizontal	Pass
		1745	16.68	3.95	8.90	21.63	145.55	Horizontal	Pass
		1772.5	17.72	3.97	8.90	22.65	184.08	Horizontal	Pass
20.0MHz Band QPSK	100/0	1720	16.34	3.81	8.90	21.43	139.00	Horizontal	Pass
		1745	17.39	3.96	8.90	22.33	171.00	Horizontal	Pass
		1770	16.53	4	8.90	21.43	139.00	Horizontal	Pass
1.4MHz Band QPSK	6/0	1710.7	17.17	3.76	8.90	22.31	170.22	Vertical	Pass
		1745	17.38	3.91	8.90	22.37	172.58	Vertical	Pass
		1779.3	16.40	3.93	8.90	21.37	137.09	Vertical	Pass
3.0MHz Band QPSK	15/0	1711.5	17.30	3.77	8.90	22.43	174.98	Vertical	Pass
		1745	16.55	3.91	8.90	21.54	142.56	Vertical	Pass
		1778.5	16.57	3.94	8.90	21.53	142.23	Vertical	Pass
5.0MHz Band QPSK	25/0	1712.5	17.34	3.77	8.90	22.47	176.60	Vertical	Pass
		1745	17.45	3.91	8.90	22.44	175.39	Vertical	Pass
		1777.5	17.31	3.94	8.90	22.27	168.66	Vertical	Pass
10.0MHz Band QPSK	50/0	1715	16.26	3.79	8.90	21.37	137.09	Vertical	Pass
		1745	17.55	3.95	8.90	22.50	177.83	Vertical	Pass
		1775	17.31	3.97	8.90	22.24	167.49	Vertical	Pass
15.0MHz Band QPSK	75/0	1717.5	17.03	3.79	8.90	22.14	163.68	Vertical	Pass
		1745	16.40	3.95	8.90	21.35	136.46	Vertical	Pass
		1772.5	16.33	3.97	8.90	21.26	133.66	Vertical	Pass
20.0MHz	100/0	1720	18.48	3.81	8.90	23.57	227.51	Vertical	Pass

Band		1745	18.02	3.96	8.90	22.96	197.70	Vertical	Pass
QPSK		1770	17.42	4	8.90	22.32	170.61	Vertical	Pass

Radiated Power (EIRP) for Band 66									
Mode	RB/RB SIZE	Frequency	Result					Polarization Of Max. ERP	Conclusion
			SG Level (dBm)	Cable Loss (dBm)	Antenna Gain (dB)	Max. EIRP Average (dBm)	Max. EIRP Average (mW)		
1.4MHz Band 16 QAM	6/0	1710.7	18.41	3.76	8.90	23.55	226.46	Horizontal	Pass
		1745	17.60	3.91	8.90	22.59	181.55	Horizontal	Pass
		1779.3	17.58	3.93	8.90	22.55	179.89	Horizontal	Pass
3.0MHz Band 16 QAM	15/0	1711.5	17.56	3.77	8.90	22.69	185.78	Horizontal	Pass
		1745	16.36	3.91	8.90	21.35	136.46	Horizontal	Pass
		1778.5	16.36	3.94	8.90	21.32	135.52	Horizontal	Pass
5.0MHz Band 16 QAM	25/0	1712.5	18.38	3.77	8.90	23.51	224.39	Horizontal	Pass
		1745	16.37	3.91	8.90	21.36	136.77	Horizontal	Pass
		1777.5	16.69	3.94	8.90	21.65	146.22	Horizontal	Pass
10.0MHz Band 16 QAM	50/0	1715	18.40	3.79	8.90	23.51	224.39	Horizontal	Pass
		1745	18.52	3.95	8.90	23.47	222.33	Horizontal	Pass
		1775	16.43	3.97	8.90	21.36	136.77	Horizontal	Pass
15.0MHz Band 16 QAM	75/0	1717.5	16.54	3.79	8.90	21.65	146.22	Horizontal	Pass
		1745	18.50	3.95	8.90	23.45	221.31	Horizontal	Pass
		1772.5	16.43	3.97	8.90	21.36	136.77	Horizontal	Pass
20.0MHz Band 16 QAM	100/0	1720	16.44	3.81	8.90	21.53	142.23	Horizontal	Pass
		1745	18.60	3.96	8.90	23.54	225.94	Horizontal	Pass
		1770	17.61	4.00	8.90	22.51	178.24	Horizontal	Pass
1.4MHz Band 16 QAM	6/0	1710.7	18.36	3.76	8.90	23.50	223.87	Vertical	Pass
		1745	17.16	3.91	8.90	22.15	164.06	Vertical	Pass
		1779.3	17.39	3.93	8.90	22.36	172.19	Vertical	Pass
3.0MHz Band 16 QAM	15/0	1711.5	18.26	3.77	8.90	23.39	218.27	Vertical	Pass
		1745	16.58	3.91	8.90	21.57	143.55	Vertical	Pass
		1778.5	16.40	3.94	8.90	21.36	136.77	Vertical	Pass
5.0MHz Band 16 QAM	25/0	1712.5	18.39	3.77	8.90	23.52	224.91	Vertical	Pass
		1745	16.66	3.91	8.90	21.65	146.22	Vertical	Pass
		1777.5	16.57	3.94	8.90	21.53	142.23	Vertical	Pass
10.0MHz Band 16 QAM	50/0	1715	18.27	3.79	8.90	23.38	217.77	Vertical	Pass
		1745	16.61	3.95	8.90	21.56	143.22	Vertical	Pass
		1775	16.60	3.97	8.90	21.53	142.23	Vertical	Pass
15.0MHz Band 16 QAM	75/0	1717.5	18.20	3.79	8.90	23.31	214.29	Vertical	Pass
		1745	16.61	3.95	8.90	21.56	143.22	Vertical	Pass
		1772.5	16.44	3.97	8.90	21.37	137.09	Vertical	Pass
20.0MHz	100/0	1720	18.47	3.81	8.90	23.56	226.99	Vertical	Pass



Band 16		1745	17.41	3.96	8.90	22.35	171.79	Vertical	Pass
QAM		1770	17.78	4	8.90	22.68	185.35	Vertical	Pass

Note:

SG Level= Signal generator output

Max. EIRP Average (dBm)= Antenna Gain(dB)+ SG Level (dBm)- Cable Loss(dBm)

Factor Gain(dB)=Antenna Gain(dB) + Amplifier Factor (dB)

## 9. SPURIOUS RADIATION EMISSION

### RULE PART(S)

FCC: §2.1053, §22.917, §24.238, §27.53 and §90.691

### LIMIT

§22.917 (e) and §24.238 and §90.691 (a): Out of band emissions. The power of any emission outside of the authorized operating frequency ranges must be attenuated below the transmitting power (P) by a factor of at least  $43 + 10 \log (P)$  dB.

§27.53 (g) For operations in the 698–746 MHz band, the power of any emission outside a licensee's frequency band(s) of operation shall be attenuated below the transmitter power (P) within the licensed band(s) of operation, measured in watts, by at least  $43 + 10 \log (P)$  dB.

§27.53 (h) For operations in the 1710–1755 MHz and 2110–2155 MHz bands, the power of any emission outside a licensee's frequency block shall be attenuated below the transmitter power (P) by at least  $43 + 10 \log_{10}(P)$  dB.

### TEST PROCEDURE

For Cellular equipment - Compliance with these rules is based on the use of measurement instrumentation employing a resolution bandwidth of 100 kHz or greater. In the 1 MHz bands immediately outside and adjacent to the frequency block a resolution bandwidth of at least one percent of the emission bandwidth of the fundamental emission of the transmitter may be employed. A narrower resolution bandwidth is permitted in all cases to improve measurement accuracy provided the measured power is integrated over the full required measurement bandwidth (i.e. 100 kHz or 1 percent of emission bandwidth, as specified). The emission bandwidth is defined as the width of the signal between two points, one below the carrier center frequency and one above the carrier center frequency, outside of which all emissions are attenuated at least 26 dB below the transmitter power.

For PCS equipment - Compliance with these rules is based on the use of measurement instrumentation employing a resolution bandwidth of 1 MHz or greater. However, in the 1 MHz bands immediately outside and adjacent to the frequency block a resolution bandwidth of at least one percent of the emission bandwidth of the fundamental emission of the transmitter may be employed. A narrower resolution bandwidth is permitted in all cases to improve measurement accuracy provided the measured power is integrated over the full required measurement bandwidth ( i.e. 1 MHz or 1 percent of emission bandwidth, as specified). The emission bandwidth is defined as the width of the signal between two points, one below the carrier center frequency and one above the carrier center frequency, outside of which all emissions are attenuated at least 26 dB below the transmitter power.

The unwanted emission power shall be measured with a resolution bandwidth of at least 1% of the occupied bandwidth in the 1 MHz band immediately outside and adjacent to the channel edge of the equipment. Beyond the 1 MHz band immediately outside the channel edge of the equipment, a resolution bandwidth of 1 MHz shall be employed. A narrower resolution bandwidth is allowed to be used provided that the measured power is integrated over the full required measurement bandwidth of 1 MHz or 1% of the occupied bandwidth as applicable.

The power of any unwanted emissions measured from the channel edge of the equipment shall be attenuated below the transmitter power, P (dBW), as follows:

- a. for base station and subscriber equipment, other than mobile subscriber equipment, the attenuation shall not be less than  $43 + 10 \text{ Log}_{10} (p)$ , dB; and
- b. for mobile subscriber equipment, the attenuation shall not be less than  $43 + 10 \text{ Log}_{10} (p)$ , dB at the channel edges and  $55 + 10 \text{ Log}_{10} (p)$  at 5.5 MHz away and beyond the channel edges where p in (a) and (b) is the transmitter power measured in watts.

**MODES TESTED**

- LTE Band 2  
LTE Band 4
- LTE Band 5  
LTE Band 7  
LTE Band 12  
LTE Band 17  
LTE Band 25,  
LTE Band 26,  
LTE Band 41,  
LTE Band 66

**RESULTS**

PASS

9.1 LTE BAND 2

**QPSK EIRP POWER FOR LTE BAND 2 (1.4MHZ BANDWIDTH)**

Test Results for Low Channel 1850.7MHz							
Frequency(MHz)	SG Level(dBm)	Cable Loss(dB)	Antenna Gain(dB)	Absolute Level(dBm)	Limit (dBm)	Margin(dBm)	Polarity
3701.4	-48.79	4.04	33.51	-19.32	-13	-6.32	Horizontal
3701.4	-49.16	4.04	33.51	-19.69	-13	-6.69	Vertical
5552.1	-52.93	5.24	35.84	-22.33	-13	-9.33	Vertical
5552.1	-63.26	5.24	35.84	-32.66	-13	-19.66	Horizontal
Test Results for Mid Channel 1880MHz							
3760	-50.80	4.04	33.56	-21.28	-13	-8.28	Horizontal
3760	-50.90	4.04	33.56	-21.38	-13	-8.38	Vertical
5640	-50.08	5.24	35.91	-19.41	-13	-6.41	Vertical
5640	-51.41	5.24	35.91	-20.74	-13	-7.74	Horizontal
Test Results for High Channel 1909.3MHz							
3818.6	-49.63	4.04	34.00	-19.67	-13	-6.67	Horizontal
3818.6	-52.68	4.04	34.00	-22.72	-13	-9.72	Vertical
5727.9	-55.61	5.24	36.04	-24.81	-13	-11.81	Vertical
5727.9	-54.31	5.24	36.04	-23.51	-13	-10.51	Horizontal

**QPSK EIRP POWER FOR LTE BAND 2 (20.0MHZ BANDWIDTH)**

Test Results for Low Channel 1860MHz							
Frequency(MHz)	SG Level(dBm)	Cable Loss(dB)	Antenna Gain(dB)	Absolute Level(dBm)	Limit (dBm)	Margin(dBm)	Polarity
3720	-52.31	4.07	33.54	-22.84	-13	-9.84	Horizontal
3720	-46.97	4.07	33.54	-17.50	-13	-4.50	Vertical
5580	-53.35	5.28	35.86	-22.77	-13	-9.77	Vertical
5580	-57.07	5.28	35.86	-26.49	-13	-13.49	Horizontal
Test Results for Mid Channel 1880MHz							
3760	-51.10	4.04	33.56	-21.58	-13	-8.58	Horizontal
3760	-47.00	4.04	33.56	-17.48	-13	-4.48	Vertical
5640	-53.38	5.24	35.91	-22.71	-13	-9.71	Vertical
5640	-53.43	5.24	35.91	-22.76	-13	-9.76	Horizontal
Test Results for High Channel 1900MHz							
3800	-50.23	4.04	34.00	-20.27	-13	-7.27	Horizontal
3800	-50.98	4.04	34.00	-21.02	-13	-8.02	Vertical
5700	-53.03	5.24	36.04	-22.23	-13	-9.23	Vertical
5700	-52.77	5.24	36.04	-21.97	-13	-8.97	Horizontal

Note: P<sub>Mea</sub>(dBm)= Power(dBm)+ AR<sub>pl</sub> (dBm)

. Over Limit= : P<sub>Mea</sub>(dBm)-Limit(dBm)

. Both QPSK and 16QAM has been tested, the worst case is QPSK mode, the report just reported the worst case.

9.2 LTE BAND 4

**QPSK EIRP POWER FOR LTE BAND 4 (1.4MHZ BANDWIDTH)**

Test Results for Low Channel 1710.7MHz							
Frequency(MHz)	SG Level(dBm)	Cable Loss(dB)	Antenna Gain(dB)	Absolute Level(dBm)	Limit (dBm)	Margin(dBm)	Polarity
3421.4	-54.55	4.02	29.80	-28.77	-13	-15.77	Horizontal
3421.4	-52.52	4.02	29.80	-26.74	-13	-13.74	Vertical
5132.1	-55.77	5.24	35.84	-25.17	-13	-12.17	Vertical
5132.1	-59.47	5.24	35.84	-28.87	-13	-15.87	Horizontal
Test Results for Mid Channel 1732.5MHz							
3465	-46.12	4.03	30.00	-20.15	-13	-7.15	Horizontal
3465	-52.10	4.03	30.00	-26.13	-13	-13.13	Vertical
5197.5	-52.40	5.25	35.86	-21.79	-13	-8.79	Vertical
5197.5	-52.67	5.25	35.86	-22.06	-13	-9.06	Horizontal
Test Results for High Channel 1754.3MHz							
3508.6	-47.02	4.05	30.01	-21.06	-13	-8.06	Horizontal
3508.6	-54.98	4.05	30.01	-29.02	-13	-16.02	Vertical
5262.9	-53.26	5.26	35.86	-22.66	-13	-9.66	Vertical
5262.9	-51.44	5.26	35.86	-20.84	-13	-7.84	Horizontal

**QPSK EIRP POWER FOR LTE BAND 4 (20.0MHZ BANDWIDTH)**

Test Results for Low Channel 1720MHz							
Frequency(MHz)	SG Level(dBm)	Cable Loss(dB)	Antenna Gain(dB)	Absolute Level(dBm)	Limit (dBm)	Margin(dBm)	Polarity
3440	-51.66	4.02	29.80	-25.88	-13	-12.88	Horizontal
3440	-52.66	4.02	29.80	-26.88	-13	-13.88	Vertical
5160	-54.54	5.24	35.84	-23.94	-13	-10.94	Vertical
5160	-57.44	5.24	35.84	-26.84	-13	-13.84	Horizontal
Test Results for Mid Channel 1732.5MHz							
3465	-47.65	4.03	30.00	-21.68	-13	-8.68	Horizontal
3465	-49.28	4.03	30.00	-23.31	-13	-10.31	Vertical
5197.5	-56.11	5.25	35.86	-25.50	-13	-12.50	Vertical
5197.5	-54.30	5.25	35.86	-23.69	-13	-10.69	Horizontal
Test Results for High Channel 1745MHz							
2490	-49.25	2.91	27.68	-24.48	-13	-11.48	Horizontal
3490	-51.94	2.91	27.68	-27.17	-13	-14.17	Vertical
5235	-55.12	5.26	35.86	-24.52	-13	-11.52	Vertical
5235	-54.24	5.26	35.86	-23.64	-13	-10.64	Horizontal

Note: P<sub>Mea</sub>(dBm)= Power(dBm)+ AR<sub>pl</sub> (dBm)

. Over Limit= : P<sub>Mea</sub>(dBm)-Limit(dBm)

. Both QPSK and 16QAM has been tested, the worst case is QPSK mode, the report just reported the worst case.

9.3 LTE BAND 5

**QPSK EIRP POWER FOR LTE BAND 5 (1.4MHZ BANDWIDTH)**

Test Results for Low Channel 824.7MHz							
Frequency(MHz)	SG Level(dBm)	Cable Loss(dB)	Antenna Gain(dB)	Absolute Level(dBm)	Limit (dBm)	Margin(dBm)	Polarity
1649.4	-45.65	2.78	27.50	-20.93	-13	-7.93	Horizontal
1649.4	-52.52	2.78	27.50	-27.80	-13	-14.80	Vertical
2474.1	-49.17	2.90	27.80	-24.27	-13	-11.27	Vertical
2474.1	-49.11	2.90	27.80	-24.21	-13	-11.21	Horizontal
Test Results For Mid Channel 836.5MHz							
1673	-48.30	2.78	27.48	-23.60	-13	-10.60	Horizontal
1673	-46.22	2.78	27.48	-21.52	-13	-8.52	Vertical
2509.5	-48.37	2.91	27.70	-23.58	-13	-10.58	Vertical
2509.5	-46.41	2.91	27.70	-21.62	-13	-8.62	Horizontal
Test Results for High Channel 848.3MHz							
1696.6	-48.39	2.78	27.43	-23.74	-13	-10.74	Horizontal
1696.6	-49.67	2.78	27.43	-25.02	-13	-12.02	Vertical
2544.9	-47.70	2.92	27.74	-22.88	-13	-9.88	Vertical
2544.9	-47.21	2.92	27.74	-22.39	-13	-9.39	Horizontal



**QPSK EIRP POWER FOR LTE BAND 5 (10MHZ BANDWIDTH)**

Test Results for Low Channel 829MHz							
Frequency(MHz)	SG Level(dBm)	Cable Loss(dB)	Antenna Gain(dB)	Absolute Level(dBm)	Limit (dBm)	Margin(dBm)	Polarity
1658	-47.89	2.78	27.50	-23.17	-13	-10.17	Horizontal
1658	-47.46	2.78	27.50	-22.74	-13	-9.74	Vertical
2487	-50.27	2.90	27.80	-25.37	-13	-12.37	Vertical
2487	-51.05	2.90	27.80	-26.15	-13	-13.15	Horizontal
Test Results for Mid Channel 836.5MHz							
1673	-48.87	2.78	27.48	-24.17	-13	-11.17	Horizontal
1673	-48.02	2.78	27.48	-23.32	-13	-10.32	Vertical
2509.5	-52.84	2.91	27.70	-28.05	-13	-15.05	Vertical
2509.5	-47.71	2.91	27.70	-22.92	-13	-9.92	Horizontal
Test Results for High Channel 844MHz							
1688	-49.81	2.78	27.43	-25.16	-13	-12.16	Horizontal
1688	-45.06	2.78	27.43	-20.41	-13	-7.41	Vertical
2532	-47.92	2.92	27.74	-23.10	-13	-10.10	Vertical
2532	-46.25	2.92	27.74	-21.43	-13	-8.43	Horizontal

Note:  $P_{Mea}(dBm) = Power(dBm) + ARpl (dBm)$

. Over Limit = :  $P_{Mea}(dBm) - Limit(dBm)$

. Both QPSK and 16QAM has been tested, the worst case is QPSK mode, the report just reported the worst case.

9.4 LTE BAND 7

**QPSK EIRP POWER FOR LTE BAND 7 (5.0MHZ BANDWIDTH)**

Test Results for Low Channel 2502.5MHz							
Frequency(MHz)	SG Level(dBm)	Cable Loss(dB)	Antenna Gain(dB)	Absolute Level(dBm)	Limit (dBm)	Margin(dBm)	Polarity
5005	-65.18	5.23	35.81	-34.60	-25	-9.60	Horizontal
5005	-63.12	5.23	35.81	-32.54	-25	-7.54	Vertical
7507.5	-67.65	5.67	36.85	-36.47	-25	-11.47	Vertical
7507.5	-63.25	5.67	36.85	-32.07	-25	-7.07	Horizontal
Test Results for Mid Channel 2535MHz							
5070	-61.39	5.23	35.82	-30.80	-25	-5.80	Horizontal
5070	-64.42	5.23	35.82	-33.83	-25	-8.83	Vertical
7605	-65.30	5.67	36.85	-34.12	-25	-9.12	Vertical
7605	-66.29	5.67	36.85	-35.11	-25	-10.11	Horizontal
Test Results for High Channel 2567.5MHz							
5135	-66.50	5.24	35.83	-35.91	-25	-10.91	Horizontal
5135	-62.75	5.24	35.83	-32.16	-25	-7.16	Vertical
7702.5	-65.49	5.68	36.87	-34.30	-25	-9.30	Vertical
7702.5	-66.90	5.68	36.87	-35.71	-25	-10.71	Horizontal

**QPSK EIRP POWER FOR LTE BAND 7 (20.0MHZ BANDWIDTH)**

Test Results for Low Channel 2510MHz							
Frequency(MHz)	SG Level(dBm)	Cable Loss(dB)	Antenna Gain(dB)	Absolute Level(dBm)	Limit (dBm)	Margin(dBm)	Polarity
5020	-64.62	5.23	35.82	-34.03	-25	-9.03	Horizontal
5020	-61.17	5.23	35.82	-30.58	-25	-5.58	Vertical
7530	-65.28	5.67	36.86	-34.09	-25	-9.09	Vertical
7530	-60.75	5.67	36.86	-29.56	-25	-4.56	Horizontal
Test Results for Mid Channel 2535MHz							
5070	-62.46	5.23	35.82	-31.87	-25	-6.87	Horizontal
5070	-62.10	5.23	35.82	-31.51	-25	-6.51	Vertical
7605	-64.41	5.67	36.85	-33.23	-25	-8.23	Vertical
7605	-65.37	5.67	36.85	-34.19	-25	-9.19	Horizontal
Test Results for High Channel 2560MHz							
5120	-59.82	5.24	35.83	-29.23	-25	-4.23	Horizontal
5120	-64.83	5.24	35.83	-34.24	-25	-9.24	Vertical
7680	-64.56	5.70	36.88	-33.38	-25	-8.38	Vertical
7680	-64.81	5.70	36.88	-33.63	-25	-8.63	Horizontal

Note: P<sub>Mea</sub>(dBm)= Power(dBm)+ AR<sub>pl</sub> (dBm)

. Over Limit= : P<sub>Mea</sub>(dBm)-Limit(dBm)

. Both QPSK and 16QAM has been tested, the worst case is QPSK mode, the report just reported the worst case.

9.5 LTE BAND 12

**QPSK EIRP POWER FOR LTE BAND 12 (1.4MHZ BANDWIDTH)**

Test Results for Low Channel 699.7MHz							
Frequency(MHz)	SG Level(dBm)	Cable Loss(dB)	Antenna Gain(dB)	Absolute Level(dBm)	Limit (dBm)	Margin(dBm)	Polarity
1399.4	-45.58	2.60	27.2	-20.98	-13	-7.98	Horizontal
1399.4	-46.05	2.60	27.2	-21.45	-13	-8.45	Vertical
2099.1	-47.97	2.85	27.54	-23.28	-13	-10.28	Vertical
2099.1	-45.01	2.85	27.54	-20.32	-13	-7.32	Horizontal
Test Results For Mid Channel 707.5MHz							
1415	-48.23	2.61	27.28	-23.56	-13	-10.56	Horizontal
1415	-46.45	2.61	27.28	-21.78	-13	-8.78	Vertical
2122.5	-43.34	2.87	27.59	-18.62	-13	-5.62	Vertical
2122.5	-49.31	2.87	27.59	-24.59	-13	-11.59	Horizontal
Test Results for High Channel 715.3MHz							
1430.6	-47.76	2.63	27.28	-23.11	-13	-10.11	Horizontal
1430.6	-52.93	2.63	27.28	-28.28	-13	-15.28	Vertical
2145.9	-50.43	2.88	27.60	-25.71	-13	-12.71	Vertical
2145.9	-47.04	2.88	27.60	-22.32	-13	-9.32	Horizontal

**QPSK EIRP POWER FOR LTE BAND 12 (10MHZ BANDWIDTH)**

Test Results for Low Channel 704MHz							
Frequency(MHz)	SG Level(dBm)	Cable Loss(dB)	Antenna Gain(dB)	Absolute Level(dBm)	Limit (dBm)	Margin(dBm)	Polarity
1408	-44.28	2.61	27.26	-19.63	-13	-6.63	Horizontal
1408	-50.08	2.61	27.26	-25.43	-13	-12.43	Vertical
2112	-48.53	2.87	27.58	-23.82	-13	-10.82	Vertical
2112	-49.38	2.87	27.58	-24.67	-13	-11.67	Horizontal
Test Results for Mid Channel 707.5MHz							
1415	-47.14	2.61	27.28	-22.47	-13	-9.47	Horizontal
1415	-51.22	2.61	27.28	-26.55	-13	-13.55	Vertical
2122.5	-49.74	2.87	27.59	-25.02	-13	-12.02	Vertical
2122.5	-46.76	2.87	27.59	-22.04	-13	-9.04	Horizontal
Test Results for High Channel 711MHz							
1422	-51.46	2.62	27.28	-26.80	-13	-13.80	Horizontal
1422	-45.27	2.62	27.28	-20.61	-13	-7.61	Vertical
2133	-50.51	2.87	27.60	-25.78	-13	-12.78	Vertical
2133	-49.84	2.87	27.60	-25.11	-13	-12.11	Horizontal

Note: P<sub>Mea</sub>(dBm)= Power(dBm)+ AR<sub>pl</sub> (dBm)

. Over Limit= : P<sub>Mea</sub>(dBm)-Limit(dBm)

. Both QPSK and 16QAM has been tested, the worst case is QPSK mode, the report just reported the worst case.

9.6 LTE BAND 17

**QPSK EIRP POWER FOR LTE BAND 17 (5MHZ BANDWIDTH)**

Test Results for Low Channel 706.5MHz							
Frequency(MHz)	SG Level(dBm)	Cable Loss(dB)	Antenna Gain(dB)	Absolute Level(dBm)	Limit (dBm)	Margin(dBm)	Polarity
1413	-52.34	2.61	27.28	-27.67	-13	-14.67	Horizontal
1413	-47.93	2.61	27.28	-23.26	-13	-10.26	Vertical
2119.5	-48.84	2.87	27.59	-24.12	-13	-11.12	Vertical
2119.5	-50.34	2.87	27.59	-25.62	-13	-12.62	Horizontal
Test Results For Mid Channel 710MHz							
1420	-50.30	2.62	27.30	-25.62	-13	-12.62	Horizontal
1420	-48.53	2.62	27.30	-23.85	-13	-10.85	Vertical
2130	-51.19	2.87	27.62	-26.44	-13	-13.44	Vertical
2130	-46.38	2.87	27.62	-21.63	-13	-8.63	Horizontal
Test Results for High Channel 713.5MHz							
1427	-46.32	2.66	27.28	-21.70	-13	-8.70	Horizontal
1427	-46.81	2.66	27.28	-22.19	-13	-9.19	Vertical
2140.5	-48.95	2.88	27.60	-24.23	-13	-11.23	Vertical
2140.5	-51.60	2.88	27.60	-26.88	-13	-13.88	Horizontal

**QPSK EIRP POWER FOR LTE BAND 17 (10MHZ BANDWIDTH)**

Test Results for Low Channel 709MHz							
Frequency(MHz)	SG Level(dBm)	Cable Loss(dB)	Antenna Gain(dB)	Absolute Level(dBm)	Limit (dBm)	Margin(dBm)	Polarity
1418	-50.57	2.62	27.30	-25.89	-13	-12.89	Horizontal
1418	-48.30	2.62	27.30	-23.62	-13	-10.62	Vertical
2127	-49.45	2.87	27.62	-24.70	-13	-11.70	Vertical
2127	-50.94	2.87	27.62	-26.19	-13	-13.19	Horizontal
Test Results for Mid Channel 710MHz							
1420	-50.78	2.62	27.30	-26.10	-13	-13.10	Horizontal
1420	-48.94	2.62	27.30	-24.26	-13	-11.26	Vertical
2130	-50.87	2.87	27.62	-26.12	-13	-13.12	Vertical
2130	-49.14	2.87	27.62	-24.39	-13	-11.39	Horizontal
Test Results for High Channel 711MHz							
1422	-47.74	2.62	27.30	-23.06	-13	-10.06	Horizontal
1422	-47.05	2.62	27.30	-22.37	-13	-9.37	Vertical
2133	-50.17	2.87	27.62	-25.42	-13	-12.42	Vertical
2133	-51.84	2.87	27.62	-27.09	-13	-14.09	Horizontal

Note: P<sub>Mea</sub>(dBm)= Power(dBm)+ AR<sub>pl</sub> (dBm)

. Over Limit= : P<sub>Mea</sub>(dBm)-Limit(dBm)

. Both QPSK and 16QAM has been tested, the worst case is QPSK mode, the report just reported the worst case.

9.7 LTE BAND 25

**QPSK EIRP POWER FOR LTE BAND 25 (1.4MHZ BANDWIDTH)**

Test Results for Low Channel 1850.7MHz							
Frequency(MHz)	SG Level(dBm)	Cable Loss(dB)	Antenna Gain(dB)	Absolute Level(dBm)	Limit (dBm)	Margin(dBm)	Polarity
3701.4	-51.15	2.61	27.26	-26.50	-13	-13.50	Horizontal
3701.4	-51.70	2.61	27.26	-27.05	-13	-14.05	Vertical
5552.1	-53.72	2.87	27.58	-29.01	-13	-16.01	Vertical
5552.1	-52.33	2.87	27.58	-27.62	-13	-14.62	Horizontal
Test Results for Mid Channel 1882.5MHz							
3765	-49.51	2.63	27.28	-24.86	-13	-11.86	Horizontal
3765	-52.31	2.63	27.28	-27.66	-13	-14.66	Vertical
5647.5	-50.30	2.88	27.62	-25.56	-13	-12.56	Vertical
5647.5	-51.52	2.88	27.62	-26.78	-13	-13.78	Horizontal
Test Results for High Channel 1914.3MHz							
3828.6	-53.62	2.65	27.28	-28.99	-13	-15.99	Horizontal
3828.6	-53.76	2.65	27.28	-29.13	-13	-16.13	Vertical
5742.9	-51.78	2.88	27.70	-26.96	-13	-13.96	Vertical
5742.9	-52.59	2.88	27.70	-27.77	-13	-14.77	Horizontal



**QPSK EIRP POWER FOR LTE BAND 25 (20MHZ BANDWIDTH)**

Test Results for Low Channel 1720MHz							
Frequency(MHz)	SG Level(dBm)	Cable Loss(dB)	Antenna Gain(dB)	Absolute Level(dBm)	Limit (dBm)	Margin(dBm)	Polarity
3720	-53.41	2.62	27.30	-28.73	-13	-15.73	Horizontal
3720	-53.66	2.62	27.30	-28.98	-13	-15.98	Vertical
5580	-53.84	2.87	27.62	-29.09	-13	-16.09	Vertical
5580	-52.00	2.87	27.62	-27.25	-13	-14.25	Horizontal
Test Results for Mid Channel 1732.5MHz							
3765	-54.02	2.64	27.33	-29.33	-13	-16.33	Horizontal
3765	-53.01	2.64	27.33	-28.32	-13	-15.32	Vertical
5647.5	-54.94	2.88	27.67	-30.15	-13	-17.15	Vertical
5647.5	-53.74	2.88	27.67	-28.95	-13	-15.95	Horizontal
Test Results for High Channel 1745MHz							
3810	-49.55	2.64	27.33	-24.86	-13	-11.86	Horizontal
3810	-54.70	2.64	27.33	-30.01	-13	-17.01	Vertical
5715	-52.03	2.88	27.67	-27.24	-13	-14.24	Vertical
5715	-51.50	2.88	27.67	-26.71	-13	-13.71	Horizontal

9.8 LTE BAND 26

**QPSK EIRP POWER FOR LTE BAND 26(814MHz~824MHz) (1.4MHZ BANDWIDTH)**

Test Results for Low Channel 814.7MHz							
Frequency(MHz)	SG Level(dBm)	Cable Loss(dB)	Antenna Gain(dB)	Absolute Level(dBm)	Limit (dBm)	Margin(dBm)	Polarity
1629.4	-48.51	2.78	27.5	-23.79	-13	-10.79	Horizontal
1629.4	-50.55	2.78	27.5	-25.83	-13	-12.83	Vertical
2444.1	-51.74	2.9	27.8	-26.84	-13	-13.84	Vertical
2444.1	-62.55	2.9	27.8	-37.65	-13	-24.65	Horizontal
Test Results For Mid Channel 819MHz							
1638	-49.58	2.8	27.48	-24.90	-13	-11.90	Horizontal
1638	-50.89	2.8	27.48	-26.21	-13	-13.21	Vertical
2457.5	-50.91	2.91	27.7	-26.12	-13	-13.12	Vertical
2457.5	-52.92	2.91	27.7	-28.13	-13	-15.13	Horizontal
Test Results for High Channel 821.5MHz							
1646.6	-49.99	2.82	27.43	-25.38	-13	-12.38	Horizontal
1646.6	-53.75	2.82	27.43	-29.14	-13	-16.14	Vertical
2469.9	-52.99	2.92	27.74	-28.17	-13	-15.17	Vertical
2469.9	-53.67	2.92	27.74	-28.85	-13	-15.85	Horizontal

**QPSK EIRP POWER FOR LTE BAND 26(814MHz~824MHz) (10MHZ BANDWIDTH)**

Test Results for Channel 819MHz							
Frequency(MHz)	SG Level(dBm)	Cable Loss(dB)	Antenna Gain(dB)	Absolute Level(dBm)	Limit (dBm)	Margin(dBm)	Polarity
1638	-52.24	2.82	27.43	-27.63	-13	-14.63	Horizontal
1638	-53.11	2.82	27.43	-28.50	-13	-15.50	Vertical
2457.5	-54.47	2.91	27.74	-29.64	-13	-16.64	Vertical
2457.5	-53.52	2.91	27.74	-28.69	-13	-15.69	Horizontal

**QPSK EIRP POWER FOR LTE BAND 26(824MHz~849MHz) (1.4MHZ BANDWIDTH)**

Test Results for Low Channel 824.7MHz							
Frequency(MHz)	SG Level(dBm)	Cable Loss(dB)	Antenna Gain(dB)	Absolute Level(dBm)	Limit (dBm)	Margin(dBm)	Polarity
1649.4	-55.29	2.78	27.28	-30.79	-13	-17.79	Horizontal
1649.4	-68.44	2.78	27.28	-43.94	-13	-30.94	Vertical
2474.1	-63.19	2.9	27.59	-38.50	-13	-25.50	Vertical
2474.1	-52.49	2.9	27.59	-27.80	-13	-14.80	Horizontal
Test Results For Mid Channel 836.5MHz							
1673	-53.00	2.78	27.3	-28.48	-13	-15.48	Horizontal
1673	-62.26	2.78	27.3	-37.74	-13	-24.74	Vertical
2509.4	-61.02	2.91	27.62	-36.31	-13	-23.31	Vertical
2509.4	-58.43	2.91	27.62	-33.72	-13	-20.72	Horizontal
Test Results for High Channel 848.3MHz							
1696.6	-60.37	2.78	27.28	-35.87	-13	-22.87	Horizontal
1696.6	-56.22	2.78	27.28	-31.72	-13	-18.72	Vertical
2544.9	-56.45	2.92	27.6	-31.77	-13	-18.77	Vertical
2544.9	-60.42	2.92	27.6	-35.74	-13	-22.74	Horizontal

**QPSK EIRP POWER FOR LTE BAND 26(824MHz~849MHz) (15MHZ BANDWIDTH)**

Test Results for Low Channel 831.5MHz							
Frequency(MHz)	SG Level(dBm)	Cable Loss(dB)	Antenna Gain(dB)	Absolute Level(dBm)	Limit (dBm)	Margin(dBm)	Polarity
1663	-50.35	2.78	27.3	-25.83	-13	-12.83	Horizontal
1663	-57.38	2.78	27.3	-32.86	-13	-19.86	Vertical
2494.5	-60.81	2.9	27.62	-36.09	-13	-23.09	Vertical
2494.5	-56.77	2.9	27.62	-32.05	-13	-19.05	Horizontal
Test Results for Mid Channel 836.5MHz							
1673	-56.35	2.78	27.3	-31.83	-13	-18.83	Horizontal
1673	-54.31	2.78	27.3	-29.79	-13	-16.79	Vertical
2509.5	-61.25	2.91	27.62	-36.54	-13	-23.54	Vertical
2509.5	-58.13	2.91	27.62	-33.42	-13	-20.42	Horizontal
Test Results for High Channel 841.5MHz							
1683	-56.44	2.78	27.3	-31.92	-13	-18.92	Horizontal
1683	-54.13	2.78	27.3	-29.61	-13	-16.61	Vertical
2524.5	-55.59	2.92	27.62	-30.89	-13	-17.89	Vertical
2524.5	-52.28	2.92	27.62	-27.58	-13	-14.58	Horizontal

9.9 LTE BAND 41

**QPSK EIRP POWER FOR LTE BAND 41 (5MHZ BANDWIDTH)**

Test Results for Low Channel 2572.5MHz							
Frequency(MHz)	SG Level(dBm)	Cable Loss(dB)	Antenna Gain(dB)	Absolute Level(dBm)	Limit (dBm)	Margin(dBm)	Polarity
5205	-59.61	2.63	27.26	-34.98	-25	-9.98	Horizontal
5205	-58.16	2.63	27.26	-33.53	-25	-8.53	Vertical
7807.5	-60.72	2.67	27.58	-35.81	-25	-10.81	Vertical
7807.5	-62.74	2.67	27.58	-37.83	-25	-12.83	Horizontal
Test Results for Mid Channel 2595MHz							
5210	-50.50	2.62	27.28	-25.84	-25	-0.84	Horizontal
5210	-55.32	2.62	27.28	-30.66	-25	-5.66	Vertical
7815	-58.79	2.85	27.62	-34.02	-25	-9.02	Vertical
7815	-56.61	2.85	27.62	-31.84	-25	-6.84	Horizontal
Test Results for High Channel 2617.5MHz							
5215	-50.44	2.64	27.28	-25.80	-25	-0.80	Horizontal
5215	-57.70	2.64	27.28	-33.06	-25	-8.06	Vertical
7822.5	-57.60	2.85	27.70	-32.75	-25	-7.75	Vertical
7822.5	-55.84	2.85	27.70	-30.99	-25	-5.99	Horizontal

**QPSK EIRP POWER FOR LTE BAND 41 (5MHZ BANDWIDTH)**

Test Results for Low Channel 2580MHz							
Frequency(MHz)	SG Level(dBm)	Cable Loss(dB)	Antenna Gain(dB)	Absolute Level(dBm)	Limit (dBm)	Margin(dBm)	Polarity
5190	-58.71	2.63	27.30	-34.04	-25	-9.04	Horizontal
5190	-53.28	2.63	27.30	-28.61	-25	-3.61	Vertical
7785	-59.75	2.67	27.62	-34.80	-25	-9.80	Vertical
7785	-62.69	2.67	27.62	-37.74	-25	-12.74	Horizontal
Test Results for Mid Channel 2595MHz							
5210	-58.38	2.62	27.33	-33.67	-25	-8.67	Horizontal
5210	-55.62	2.62	27.33	-30.91	-25	-5.91	Vertical
7815	-60.08	2.85	27.67	-35.26	-25	-10.26	Vertical
7815	-59.98	2.85	27.67	-35.16	-25	-10.16	Horizontal
Test Results for High Channel 2610MHz							
5230	-56.53	2.64	27.33	-31.84	-25	-6.84	Horizontal
5230	-58.85	2.64	27.33	-34.16	-25	-9.16	Vertical
7845	-60.23	2.85	27.67	-35.41	-25	-10.41	Vertical
7845	-56.90	2.85	27.67	-32.08	-25	-7.08	Horizontal

9.10 LTE BAND 66

**QPSK EIRP POWER FOR LTE BAND 66 (1.4MHZ BANDWIDTH)**

Test Results for Low Channel 1710.7MHz							
Frequency(MHz)	SG Level(dBm)	Cable Loss(dB)	Antenna Gain(dB)	Absolute Level(dBm)	Limit (dBm)	Margin(dBm)	Polarity
3421.4	-55.17	2.61	27.28	-30.50	-13	-17.50	Horizontal
3421.4	-58.77	2.61	27.28	-34.10	-13	-21.10	Vertical
5132.1	-62.68	2.87	27.59	-37.96	-13	-24.96	Vertical
5132.1	-50.48	2.87	27.59	-25.76	-13	-12.76	Horizontal
Test Results for Mid Channel 1745MHz							
3490	-53.00	2.62	27.3	-28.32	-13	-15.32	Horizontal
3490	-61.03	2.62	27.3	-36.35	-13	-23.35	Vertical
5337.9	-60.55	2.87	27.62	-35.80	-13	-22.80	Vertical
5337.9	-56.91	2.87	27.62	-32.16	-13	-19.16	Horizontal
Test Results for High Channel 1779.3MHz							
3558.6	-57.20	2.66	27.28	-32.58	-13	-19.58	Horizontal
3558.6	-53.20	2.66	27.28	-28.58	-13	-15.58	Vertical
5337.9	-54.62	2.88	27.6	-29.90	-13	-16.90	Vertical
5337.9	-59.51	2.88	27.6	-34.79	-13	-21.79	Horizontal

**QPSK EIRP POWER FOR LTE BAND 66 (20MHZ BANDWIDTH)**

Test Results for Low Channel 1720MHz							
Frequency(MHz)	SG Level(dBm)	Cable Loss(dB)	Antenna Gain(dB)	Absolute Level(dBm)	Limit (dBm)	Margin(dBm)	Polarity
3440	-50.16	2.62	27.3	-25.48	-13	-12.48	Horizontal
3440	-55.95	2.62	27.3	-31.27	-13	-18.27	Vertical
5160	-57.63	2.87	27.62	-32.88	-13	-19.88	Vertical
5160	-54.83	2.87	27.62	-30.08	-13	-17.08	Horizontal
Test Results for Mid Channel 1745MHz							
3490	-55.01	2.62	27.3	-30.33	-13	-17.33	Horizontal
3490	-54.00	2.62	27.3	-29.32	-13	-16.32	Vertical
5337.9	-60.12	2.87	27.62	-35.37	-13	-22.37	Vertical
5337.9	-57.66	2.87	27.62	-32.91	-13	-19.91	Horizontal
Test Results for High Channel 1770MHz							
3540	-56.12	2.62	27.3	-31.44	-13	-18.44	Horizontal
3540	-53.78	2.62	27.3	-29.10	-13	-16.10	Vertical
5310	-53.74	2.87	27.62	-28.99	-13	-15.99	Vertical
5310	-50.93	2.87	27.62	-26.18	-13	-13.18	Horizontal

Note: P<sub>Mea</sub>(dBm)= Power(dBm)+ AR<sub>pl</sub> (dBm)

. Over Limit= : P<sub>Mea</sub>(dBm)-Limit(dBm)

. We test both H direction and V direction, recorded worst case direction.

Both QPSK and 16QAM has been tested, the worst case is QPSK mode, the report just reported the worst case.



## 10. FREQUENCY STABILITY

### RULE PART(S)

FCC: §2.1055, §22.355, §24.235, §27.54, §90.213

### LIMITS

§22.355 - The carrier frequency shall not depart from the reference frequency in excess of  $\pm 2.5$  ppm for mobile stations.

§24.235 - The frequency stability shall be sufficient to ensure that the fundamental emission stays within the authorized frequency block.

### TEST PROCEDURE

Use CMW 500 with Frequency Error measurement capability.

- Temp. =  $-30^{\circ}$  to  $+50^{\circ}\text{C}$
- Voltage = low voltage, DC 3.4V, Normal, DC 3.85V and High voltage, DC 4.2V.

### Frequency Stability vs Temperature:

The EUT is placed inside a temperature chamber. The temperature is set to  $-30^{\circ}\text{C}$  and allowed to stabilize. After sufficient soak time, the transmitting frequency error is measured. The temperature is increased by 10 degrees, allowed to stabilize and soak, and then the measurement is repeated. This is repeated until  $+50^{\circ}\text{C}$  is reached.

### Frequency Stability vs Voltage:

The peak frequency error is recorded (worst-case).

### MODES TESTED

- LTE Band 2  
LTE Band 4
- LTE Band 5  
LTE Band 7  
LTE Band 12  
LTE Band 17  
LTE Band 25,  
LTE Band 26,  
LTE Band 41,  
LTE Band 66

## RESULTS

See the following pages.

10.1 LTE BAND 2

QPSK, (20MHz BANDWIDTH)

**Frequency error vs. Voltage**

Voltage [Vdc]	Frequency [MHz]	Frequency* Error[Hz]	Frequency Error[ppm]	Limit [ppm]
<b>BAND 2 QPSK, (CH 18900 RB size 100 RB Offset 0 20MHz BANDWIDTH)</b>				
3.4	1880	7	0.00372	2.5
3.85	1880	19	0.01011	2.5
4.2	1880	8	0.00426	2.5

**Frequency error vs. Temperature**

Temperature [°C]	Frequency [MHz]	Frequency* Error[Hz]	Frequency Error[ppm]	Limit [ppm]
<b>BAND 2 QPSK, (CH 18900 RB size 100 RB Offset 0 20MHz BANDWIDTH)</b>				
Normal (25C)	1880	2	0.00106	2.5
Extreme (50C)	1880	0	0.00000	2.5
Extreme (40C)	1880	2	0.00106	2.5
Extreme (30C)	1880	11	0.00585	2.5
Extreme (10C)	1880	1	0.00053	2.5
Extreme (0C)	1880	12	0.00638	2.5
Extreme (-10C)	1880	8	0.00426	2.5
Extreme (-20C)	1880	13	0.00691	2.5
Extreme (-30C)	1880	9	0.00479	2.5

**16QAM, (20MHz BANDWIDTH)**

**Frequency error vs. Voltage**

Voltage [Vdc]	Frequency [MHz]	Frequency* Error[Hz]	Frequency Error[ppm]	Limit [ppm]
<b>BAND 2 16QAM, (CH 18900 RB size 100 RB Offset 0 20MHz BANDWIDTH)</b>				
3.4	1880	9	0.00479	2.5
3.85	1880	5	0.00266	2.5
4.2	1880	1	0.00053	2.5

**Frequency error vs. Temperature**

Temperature [°C]	Frequency [MHz]	Frequency* Error[Hz]	Frequency Error[ppm]	Limit [ppm]
<b>BAND 2 16QAM, (CH 18900 RB size 100 RB Offset 0 20MHz BANDWIDTH)</b>				
Normal (25C)	1880	14	0.00745	2.5
Extreme (50C)	1880	15	0.00798	2.5
Extreme (40C)	1880	22	0.01170	2.5
Extreme (30C)	1880	12	0.00638	2.5
Extreme (10C)	1880	5	0.00266	2.5
Extreme (0C)	1880	26	0.01383	2.5
Extreme (-10C)	1880	4	0.00213	2.5
Extreme (-20C)	1880	18	0.00957	2.5
Extreme (-30C)	1880	11	0.00585	2.5

**\*Note:** Frequency error measurements were made by using the build-in capability of the Wireless Communication Test Set.

10.2 LTE BAND 4

QPSK, (10MHz BANDWIDTH)

**Frequency error vs. Voltage**

Voltage [Vdc]	Frequency [MHz]	Frequency* Error[Hz]	Frequency Error[ppm]	Limit [ppm]
<b>BAND 4 QPSK, (CH 20175 RB size 100 RB Offset 0 20MHz BANDWIDTH)</b>				
3.4	1732.5	20	0.01154	2.5
3.85	1732.5	9	0.00519	2.5
4.2	1732.5	16	0.00924	2.5

**Frequency error vs. Temperature**

Temperature [°C]	Frequency [MHz]	Frequency* Error[Hz]	Frequency Error[ppm]	Limit [ppm]
<b>BAND 4 QPSK, (CH 20175 RB size 100 RB Offset 0 20MHz BANDWIDTH)</b>				
Normal (25C)	1732.5	3	0.00173	2.5
Extreme (50C)	1732.5	0	0.00000	2.5
Extreme (40C)	1732.5	12	0.00693	2.5
Extreme (30C)	1732.5	17	0.00981	2.5
Extreme (10C)	1732.5	22	0.01270	2.5
Extreme (0C)	1732.5	16	0.00924	2.5
Extreme (-10C)	1732.5	1	0.00058	2.5
Extreme (-20C)	1732.5	9	0.00519	2.5
Extreme (-30C)	1732.5	7	0.00404	2.5

**16QAM, (20MHz BANDWIDTH)**

**Frequency error vs. Voltage**

Voltage [Vdc]	Frequency [MHz]	Frequency* Error[Hz]	Frequency Error[ppm]	Limit [ppm]
<b>BAND 4 16QAM, (CH 20175 RB size 100 RB Offset 0 20MHz BANDWIDTH)</b>				
3.4	1732.5	2	0.00115	2.5
3.85	1732.5	21	0.01212	2.5
4.2	1732.5	10	0.00577	2.5

**Frequency error vs. Temperature**

Temperature [°C]	Frequency [MHz]	Frequency* Error[Hz]	Frequency Error[ppm]	Limit [ppm]
<b>BAND 4 16QAM, (CH 20175 RB size 100 RB Offset 0 20MHz BANDWIDTH)</b>				
Normal (25C)	1732.5	23	0.01328	2.5
Extreme (50C)	1732.5	26	0.01501	2.5
Extreme (40C)	1732.5	16	0.00924	2.5
Extreme (30C)	1732.5	23	0.01328	2.5
Extreme (10C)	1732.5	20	0.01154	2.5
Extreme (0C)	1732.5	20	0.01154	2.5
Extreme (-10C)	1732.5	25	0.01443	2.5
Extreme (-20C)	1732.5	10	0.00577	2.5
Extreme (-30C)	1732.5	22	0.01270	2.5

**\*Note:** Frequency error measurements were made by using the build-in capability of the Wireless Communication Test Set.

10.3 LTE BAND 5

QPSK, (10MHz BANDWIDTH)

**Frequency error vs. Voltage**

Voltage [Vdc]	Frequency [MHz]	Frequency* Error[Hz]	Frequency Error[ppm]	Limit [ppm]
<b>BAND 5 QPSK, (CH 20525 RB size 50 RB Offset 0 10MHz BANDWIDTH)</b>				
3.4	836.5	6	0.00717	2.5
3.85	836.5	13	0.01554	2.5
4.2	836.5	8	0.00956	2.5

**Frequency error vs. Temperature**

Temperature [°C]	Frequency [MHz]	Frequency* Error[Hz]	Frequency Error[ppm]	Limit [ppm]
<b>BAND 5 QPSK, (CH 20525 RB size 50 RB Offset 0 10MHz BANDWIDTH)</b>				
Normal (25C)	836.5	4	0.00478	2.5
Extreme (50C)	836.5	14	0.01674	2.5
Extreme (40C)	836.5	5	0.00598	2.5
Extreme (30C)	836.5	17	0.02032	2.5
Extreme (10C)	836.5	19	0.02271	2.5
Extreme (0C)	836.5	1	0.00120	2.5
Extreme (-10C)	836.5	6	0.00717	2.5
Extreme (-20C)	836.5	8	0.00956	2.5
Extreme (-30C)	836.5	12	0.01435	2.5

**16QAM, (10MHz BANDWIDTH)**

**Frequency error vs. Voltage**

Voltage [Vdc]	Frequency [MHz]	Frequency* Error[Hz]	Frequency Error[ppm]	Limit [ppm]
<b>BAND 5 16QAM, (CH 20525 RB size 50 RB Offset 0 10MHz BANDWIDTH)</b>				
3.4	836.5	17	0.02032	2.5
3.85	836.5	15	0.01793	2.5
4.2	836.5	1	0.00120	2.5

**Frequency error vs. Temperature**

Temperature [°C]	Frequency [MHz]	Frequency* Error[Hz]	Frequency Error[ppm]	Limit [ppm]
<b>BAND 5 16QAM, (CH 20525 RB size 50 RB Offset 0 10MHz BANDWIDTH)</b>				
Normal (25C)	836.5	13	0.01554	2.5
Extreme (50C)	836.5	11	0.01315	2.5
Extreme (40C)	836.5	5	0.00598	2.5
Extreme (30C)	836.5	19	0.02271	2.5
Extreme (10C)	836.5	14	0.01674	2.5
Extreme (0C)	836.5	2	0.00239	2.5
Extreme (-10C)	836.5	15	0.01793	2.5
Extreme (-20C)	836.5	14	0.01674	2.5
Extreme (-30C)	836.5	21	0.02510	2.5

**\*Note:** Frequency error measurements were made by using the build-in capability of the Wireless Communication Test Set.

10.4 LTE BAND 7

QPSK, (20MHz BANDWIDTH)

**Frequency error vs. Voltage**

Voltage [Vdc]	Frequency [MHz]	Frequency* Error[Hz]	Frequency Error[ppm]	Limit [ppm]
<b>BAND 7 QPSK, (CH 21100 RB size 100 RB Offset 0 20MHz BANDWIDTH)</b>				
3.4	2535	8	0.00316	2.5
3.85	2535	14	0.00552	2.5
4.2	2535	3	0.00118	2.5

**Frequency error vs. Temperature**

Temperature [°C]	Frequency [MHz]	Frequency* Error[Hz]	Frequency Error[ppm]	Limit [ppm]
<b>BAND 7 QPSK, (CH 21100 RB size 100 RB Offset 0 20MHz BANDWIDTH)</b>				
Normal (25C)	2535	3	0.00118	2.5
Extreme (50C)	2535	13	0.00513	2.5
Extreme (40C)	2535	26	0.01026	2.5
Extreme (30C)	2535	1	0.00039	2.5
Extreme (10C)	2535	22	0.00868	2.5
Extreme (0C)	2535	6	0.00237	2.5
Extreme (-10C)	2535	5	0.00197	2.5
Extreme (-20C)	2535	20	0.00789	2.5
Extreme (-30C)	2535	12	0.00473	2.5



**16QAM, (20MHz BANDWIDTH)**

**Frequency error vs. Voltage**

Voltage [Vdc]	Frequency [MHz]	Frequency* Error[Hz]	Frequency Error[ppm]	Limit [ppm]
<b>BAND 7 16QAM, (CH 21100 RB size 100 RB Offset 0 20MHz BANDWIDTH)</b>				
3.4	2535	22	0.00868	2.5
3.85	2535	18	0.00710	2.5
4.2	2535	11	0.00434	2.5

**Frequency error vs. Temperature**

Temperature [°C]	Frequency [MHz]	Frequency* Error[Hz]	Frequency Error[ppm]	Limit [ppm]
<b>BAND 7 16QAM, (CH 21100 RB size 100 RB Offset 0 20MHz BANDWIDTH)</b>				
Normal (25C)	2535	22	0.00868	2.5
Extreme (50C)	2535	23	0.00907	2.5
Extreme (40C)	2535	19	0.00750	2.5
Extreme (30C)	2535	4	0.00158	2.5
Extreme (10C)	2535	5	0.00197	2.5
Extreme (0C)	2535	25	0.00986	2.5
Extreme (-10C)	2535	11	0.00434	2.5
Extreme (-20C)	2535	23	0.00907	2.5
Extreme (-30C)	2535	4	0.00158	2.5

**\*Note:** Frequency error measurements were made by using the build-in capability of the Wireless Communication Test Set.

10.5 LTE BAND 12

QPSK, (10MHz BANDWIDTH)

**Frequency error vs. Voltage**

Voltage [Vdc]	Frequency [MHz]	Frequency* Error[Hz]	Frequency Error[ppm]	Limit [ppm]
<b>BAND 12 QPSK, (CH 23095 RB size 50 RB Offset 0 10MHz BANDWIDTH)</b>				
3.4	707.5	22	0.03110	2.5
3.85	707.5	23	0.03251	2.5
4.2	707.5	11	0.01555	2.5

**Frequency error vs. Temperature**

Temperature [°C]	Frequency [MHz]	Frequency* Error[Hz]	Frequency Error[ppm]	Limit [ppm]
<b>BAND 12 QPSK, (CH 23095 RB size 50 RB Offset 0 10MHz BANDWIDTH)</b>				
Normal (25C)	707.5	3	0.00424	2.5
Extreme (50C)	707.5	14	0.01979	2.5
Extreme (40C)	707.5	25	0.03534	2.5
Extreme (30C)	707.5	23	0.03251	2.5
Extreme (10C)	707.5	4	0.00565	2.5
Extreme (0C)	707.5	22	0.03110	2.5
Extreme (-10C)	707.5	11	0.01555	2.5
Extreme (-20C)	707.5	20	0.02827	2.5
Extreme (-30C)	707.5	1	0.00141	2.5

**16QAM, (10MHz BANDWIDTH)**

**Frequency error vs. Voltage**

Voltage [Vdc]	Frequency [MHz]	Frequency* Error[Hz]	Frequency Error[ppm]	Limit [ppm]
<b>BAND 12 16QAM, (CH 23095 RB size 50 RB Offset 0 10MHz BANDWIDTH)</b>				
3.4	707.5	11	0.01555	2.5
3.85	707.5	18	0.02544	2.5
4.2	707.5	11	0.01555	2.5

**Frequency error vs. Temperature**

Temperature [°C]	Frequency [MHz]	Frequency* Error[Hz]	Frequency Error[ppm]	Limit [ppm]
<b>BAND 12 QPSK, (CH 23095 RB size 50 RB Offset 0 10MHz BANDWIDTH)</b>				
Normal (25C)	707.5	5	0.00707	2.5
Extreme (50C)	707.5	4	0.00565	2.5
Extreme (40C)	707.5	19	0.02686	2.5
Extreme (30C)	707.5	23	0.03251	2.5
Extreme (10C)	707.5	12	0.01696	2.5
Extreme (0C)	707.5	18	0.02544	2.5
Extreme (-10C)	707.5	3	0.00424	2.5
Extreme (-20C)	707.5	22	0.03110	2.5
Extreme (-30C)	707.5	19	0.02686	2.5

**\*Note:** Frequency error measurements were made by using the build-in capability of the Wireless Communication Test Set.

10.6 LTE BAND 17

QPSK, (10MHz BANDWIDTH)

**Frequency error vs. Voltage**

Voltage [Vdc]	Frequency [MHz]	Frequency* Error[Hz]	Frequency Error[ppm]	Limit [ppm]
<b>BAND 17 QPSK, (CH 23790 RB size 50 RB Offset 0 10MHz BANDWIDTH)</b>				
3.4	710	4	0.00563	2.5
3.85	710	9	0.01268	2.5
4.2	710	18	0.02535	2.5

**Frequency error vs. Temperature**

Temperature [°C]	Frequency [MHz]	Frequency* Error[Hz]	Frequency Error[ppm]	Limit [ppm]
<b>BAND 17 QPSK, (CH 23790 RB size 50 RB Offset 0 10MHz BANDWIDTH)</b>				
Normal (25C)	710	4	0.00563	2.5
Extreme (50C)	710	20	0.02817	2.5
Extreme (40C)	710	22	0.03099	2.5
Extreme (30C)	710	14	0.01972	2.5
Extreme (10C)	710	25	0.03521	2.5
Extreme (0C)	710	19	0.02676	2.5
Extreme (-10C)	710	3	0.00423	2.5
Extreme (-20C)	710	18	0.02535	2.5
Extreme (-30C)	710	15	0.02113	2.5

**16QAM, (10MHz BANDWIDTH)**

**Frequency error vs. Voltage**

Voltage [Vdc]	Frequency [MHz]	Frequency* Error[Hz]	Frequency Error[ppm]	Limit [ppm]
<b>BAND 17 16QAM, (CH 23790 RB size 50 RB Offset 0 10MHz BANDWIDTH)</b>				
3.4	710	6	0.00845	2.5
3.85	710	17	0.02394	2.5
4.2	710	8	0.01127	2.5

**Frequency error vs. Temperature**

Temperature [°C]	Frequency [MHz]	Frequency* Error[Hz]	Frequency Error[ppm]	Limit [ppm]
<b>BAND 17 QPSK, (CH 23790 RB size 50 RB Offset 0 10MHz BANDWIDTH)</b>				
Normal (25C)	710	5	0.00704	2.5
Extreme (50C)	710	26	0.03662	2.5
Extreme (40C)	710	10	0.01408	2.5
Extreme (30C)	710	22	0.03099	2.5
Extreme (10C)	710	18	0.02535	2.5
Extreme (0C)	710	25	0.03521	2.5
Extreme (-10C)	710	15	0.02113	2.5
Extreme (-20C)	710	20	0.02817	2.5
Extreme (-30C)	710	25	0.03521	2.5

**\*Note:** Frequency error measurements were made by using the build-in capability of the Wireless Communication Test Set.

10.7 LTE BAND 25

**QPSK, (20MHz BANDWIDTH)**

**Frequency error vs. Voltage**

Voltage [Vdc]	Frequency [MHz]	Frequency* Error[Hz]	Frequency Error[ppm]	Limit [ppm]
<b>BAND 25 QPSK, (CH 26365 RB size 100 RB Offset 0 20MHz BANDWIDTH)</b>				
3.4	1882.5	18	0.00372	2.5
3.85	1882.5	9	0.01381	2.5
4.2	1882.5	10	0.00106	2.5

**Frequency error vs. Temperature**

Temperature [°C]	Frequency [MHz]	Frequency* Error[Hz]	Frequency Error[ppm]	Limit [ppm]
<b>BAND 25 QPSK, (CH 26365 RB size 100 RB Offset 0 20MHz BANDWIDTH)</b>				
Normal (25C)	1882.5	10	0.01169	2.5
Extreme (50C)	1882.5	4	0.00372	2.5
Extreme (40C)	1882.5	6	0.01487	2.5
Extreme (30C)	1882.5	4	0.01541	2.5
Extreme (10C)	1882.5	14	0.01487	2.5
Extreme (0C)	1882.5	5	0.00903	2.5
Extreme (-10C)	1882.5	24	0.01328	2.5
Extreme (-20C)	1882.5	18	0.01169	2.5
Extreme (-30C)	1882.5	10	0.00850	2.5

**16QAM, (20MHz BANDWIDTH)**

**Frequency error vs. Voltage**

Voltage [Vdc]	Frequency [MHz]	Frequency* Error[Hz]	Frequency Error[ppm]	Limit [ppm]
<b>BAND 25 16QAM, (CH 26365 RB size 100 RB Offset 0 20MHz BANDWIDTH)</b>				
3.4	1882.5	21	0.00744	2.5
3.85	1882.5	15	0.01009	2.5
4.2	1882.5	24	0.00850	2.5

**Frequency error vs. Temperature**

Temperature [°C]	Frequency [MHz]	Frequency* Error[Hz]	Frequency Error[ppm]	Limit [ppm]
<b>BAND 25 16QAM, (CH 26365 RB size 100 RB Offset 0 20MHz BANDWIDTH)</b>				
Normal (25C)	1882.5	9	0.01381	2.5
Extreme (50C)	1882.5	5	0.00159	2.5
Extreme (40C)	1882.5	11	0.00425	2.5
Extreme (30C)	1882.5	3	0.01541	2.5
Extreme (10C)	1882.5	27	0.00266	2.5
Extreme (0C)	1882.5	10	0.00637	2.5
Extreme (-10C)	1882.5	24	0.01169	2.5
Extreme (-20C)	1882.5	22	0.00584	2.5
Extreme (-30C)	1882.5	6	0.00372	2.5

**\*Note:** Frequency error measurements were made by using the build-in capability of the Wireless Communication Test Set.

10.8 LTE BAND 26

**Band 26 A (814MHz~824MHz) QPSK,10MHz BANDWIDTH)**

**Frequency error vs. Voltage**

Voltage [Vdc]	Frequency [MHz]	Frequency* Error[Hz]	Frequency Error[ppm]	Limit [ppm]
<b>BAND 26A QPSK, (CH 26740 RB size 50 RB Offset 0 10MHz BANDWIDTH)</b>				
3.4	819	6	0.00733	2.5
3.85	819	31	0.03785	2.5
4.2	819	14	0.01709	2.5

**Frequency error vs. Temperature**

Temperature [°C]	Frequency [MHz]	Frequency* Error[Hz]	Frequency Error[ppm]	Limit [ppm]
<b>BAND 26A QPSK, (CH 26740RB size 50 RB Offset 0 10MHz BANDWIDTH)</b>				
Normal (25C)	819	8	0.00977	2.5
Extreme (50C)	819	25	0.03053	2.5
Extreme (40C)	819	26	0.03175	2.5
Extreme (30C)	819	22	0.02686	2.5
Extreme (10C)	819	6	0.00733	2.5
Extreme (0C)	819	20	0.02442	2.5
Extreme (-10C)	819	29	0.03541	2.5
Extreme (-20C)	819	13	0.01587	2.5
Extreme (-30C)	819	6	0.00733	2.5



**Band 26 (814MHz~824MHz) 16QAM, (10MHz BANDWIDTH)**

**Frequency error vs. Voltage**

Voltage [Vdc]	Frequency [MHz]	Frequency* Error[Hz]	Frequency Error[ppm]	Limit [ppm]
<b>BAND 26A 16QAM, (CH 26740 RB size 50 RB Offset 0 10MHz BANDWIDTH)</b>				
3.4	819	10	0.01221	2.5
3.85	819	9	0.01099	2.5
4.2	819	14	0.01709	2.5

**Frequency error vs. Temperature**

Temperature [°C]	Frequency [MHz]	Frequency* Error[Hz]	Frequency Error[ppm]	Limit [ppm]
<b>BAND 26A 16QAM, (CH 26740 RB size 50 RB Offset 0 10MHz BANDWIDTH)</b>				
Normal (25C)	819	28	0.03053	2.5
Extreme (50C)	819	27	0.00611	2.5
Extreme (40C)	819	15	0.02808	2.5
Extreme (30C)	819	29	0.02930	2.5
Extreme (10C)	819	16	0.03663	2.5
Extreme (0C)	819	13	0.01709	2.5
Extreme (-10C)	819	16	0.03297	2.5
Extreme (-20C)	819	10	0.01221	2.5
Extreme (-30C)	819	9	0.01099	2.5

**\*Note:** Frequency error measurements were made by using the build-in capability of the Wireless Communication Test Set.

**Band 26B ((824MHz~849MHz) QPSK,15MHz BANDWIDTH)**

**Frequency error vs. Voltage**

Voltage [Vdc]	Frequency [MHz]	Frequency* Error[Hz]	Frequency Error[ppm]	Limit [ppm]
<b>BAND 26B QPSK, (CH 26915 RB size 75 RB Offset 0 15MHz BANDWIDTH)</b>				
3.4	836.5	18	0.02152	2.5
3.85	836.5	22	0.02630	2.5
4.2	836.5	11	0.01315	2.5

**Frequency error vs. Temperature**

Temperature [°C]	Frequency [MHz]	Frequency* Error[Hz]	Frequency Error[ppm]	Limit [ppm]
<b>BAND 26B QPSK, (CH 26915 RB size 75 RB Offset 0 15MHz BANDWIDTH)</b>				
Normal (25C)	836.5	7	0.00837	2.5
Extreme (50C)	836.5	20	0.02391	2.5
Extreme (40C)	836.5	6	0.00717	2.5
Extreme (30C)	836.5	3	0.00359	2.5
Extreme (10C)	836.5	15	0.01793	2.5
Extreme (0C)	836.5	7	0.00837	2.5
Extreme (-10C)	836.5	16	0.01913	2.5
Extreme (-20C)	836.5	29	0.03467	2.5
Extreme (-30C)	836.5	9	0.01076	2.5

**Band 26B (824MHz~849MHz) 16QAM, (15MHz BANDWIDTH)**

**Frequency error vs. Voltage**

Voltage [Vdc]	Frequency [MHz]	Frequency* Error[Hz]	Frequency Error[ppm]	Limit [ppm]
<b>BAND 26B 16QAM, (CH 26915 RB size 75 RB Offset 0 15MHz BANDWIDTH)</b>				
3.4	836.5	11	0.01315	2.5
3.85	836.5	20	0.02391	2.5
4.2	836.5	22	0.02630	2.5

**Frequency error vs. Temperature**

Temperature [°C]	Frequency [MHz]	Frequency* Error[Hz]	Frequency Error[ppm]	Limit [ppm]
<b>BAND 26B 16QAM, (CH 26915 RB size 75 RB Offset 0 15MHz BANDWIDTH)</b>				
Normal (25C)	836.5	16	0.01913	2.5
Extreme (50C)	836.5	24	0.02869	2.5
Extreme (40C)	836.5	28	0.03347	2.5
Extreme (30C)	836.5	30	0.03586	2.5
Extreme (10C)	836.5	19	0.02271	2.5
Extreme (0C)	836.5	26	0.03108	2.5
Extreme (-10C)	836.5	7	0.00837	2.5
Extreme (-20C)	836.5	4	0.01124	2.5
Extreme (-30C)	836.5	10	0.00729	2.5

**\*Note:** Frequency error measurements were made by using the build-in capability of the Wireless Communication

10.9 LTE BAND 41

QPSK, (20MHz BANDWIDTH)

**Frequency error vs. Voltage**

Voltage [Vdc]	Frequency [MHz]	Frequency* Error[Hz]	Frequency Error[ppm]	Limit [ppm]
<b>BAND 41 QPSK, (CH 40640 RB size 100 RB Offset 0 20MHz BANDWIDTH)</b>				
3.4	2595	8	0.00308	2.5
3.85	2595	33	0.01272	2.5
4.2	2595	7	0.00270	2.5

**Frequency error vs. Temperature**

Temperature [°C]	Frequency [MHz]	Frequency* Error[Hz]	Frequency Error[ppm]	Limit [ppm]
<b>BAND 41 QPSK, (CH 40640 RB size 100 RB Offset 0 20MHz BANDWIDTH)</b>				
Normal (25C)	2595	24	0.00925	2.5
Extreme (50C)	2595	4	0.00154	2.5
Extreme (40C)	2595	23	0.00886	2.5
Extreme (30C)	2595	9	0.00347	2.5
Extreme (10C)	2595	14	0.00539	2.5
Extreme (0C)	2595	7	0.00270	2.5
Extreme (-10C)	2595	19	0.00732	2.5
Extreme (-20C)	2595	27	0.01040	2.5
Extreme (-30C)	2595	18	0.00694	2.5

**16QAM, (20MHz BANDWIDTH)**

**Frequency error vs. Voltage**

Voltage [Vdc]	Frequency [MHz]	Frequency* Error[Hz]	Frequency Error[ppm]	Limit [ppm]
<b>BAND 41 16QAM, (CH 40640 RB size 100 RB Offset 0 20MHz BANDWIDTH)</b>				
3.4	2595	6	0.00231	2.5
3.85	2595	24	0.00925	2.5
4.2	2595	12	0.00462	2.5

**Frequency error vs. Temperature**

Temperature [°C]	Frequency [MHz]	Frequency* Error[Hz]	Frequency Error[ppm]	Limit [ppm]
<b>BAND 41 16QAM, (CH 40640 RB size 100 RB Offset 0 20MHz BANDWIDTH)</b>				
Normal (25C)	2595	12	0.00462	2.5
Extreme (50C)	2595	2	0.00077	2.5
Extreme (40C)	2595	10	0.00385	2.5
Extreme (30C)	2595	26	0.01002	2.5
Extreme (10C)	2595	13	0.00501	2.5
Extreme (0C)	2595	12	0.00462	2.5
Extreme (-10C)	2595	5	0.00193	2.5
Extreme (-20C)	2595	5	0.00193	2.5
Extreme (-30C)	2595	8	0.00308	2.5

**\*Note:** Frequency error measurements were made by using the build-in capability of the Wireless Communication Test Set.

10.10 LTE BAND 66

QPSK, (20MHz BANDWIDTH)

**Frequency error vs. Voltage**

Voltage [Vdc]	Frequency [MHz]	Frequency* Error[Hz]	Frequency Error[ppm]	Limit [ppm]
<b>BAND 66 QPSK, (CH 132322 RB size 100 RB Offset 0 20MHz BANDWIDTH)</b>				
3.4	1745	17	0.00974	2.5
3.85	1745	24	0.01375	2.5
4.2	1745	19	0.01089	2.5

**Frequency error vs. Temperature**

Temperature [°C]	Frequency [MHz]	Frequency* Error[Hz]	Frequency Error[ppm]	Limit [ppm]
<b>BAND 66 QPSK, (CH 132322 RB size 100 RB Offset 0 20MHz BANDWIDTH)</b>				
Normal (25C)	1745	11	0.00630	2.5
Extreme (50C)	1745	2	0.00115	2.5
Extreme (40C)	1745	8	0.00458	2.5
Extreme (30C)	1745	15	0.00860	2.5
Extreme (10C)	1745	14	0.00802	2.5
Extreme (0C)	1745	17	0.00974	2.5
Extreme (-10C)	1745	25	0.01433	2.5
Extreme (-20C)	1745	32	0.01834	2.5
Extreme (-30C)	1745	34	0.01948	2.5

**16QAM, (20MHz BANDWIDTH)**

**Frequency error vs. Voltage**

Voltage [Vdc]	Frequency [MHz]	Frequency* Error[Hz]	Frequency Error[ppm]	Limit [ppm]
<b>BAND 66 16QAM, (CH 132322 RB size 100 RB Offset 0 20MHz BANDWIDTH)</b>				
3.4	1745	23	0.01318	2.5
3.85	1745	7	0.00401	2.5
4.2	1745	20	0.01146	2.5

**Frequency error vs. Temperature**

Temperature [°C]	Frequency [MHz]	Frequency* Error[Hz]	Frequency Error[ppm]	Limit [ppm]
<b>BAND 66 16QAM, (CH 132322 RB size 100 RB Offset 0 20MHz BANDWIDTH)</b>				
Normal (25C)	1745	6	0.00344	2.5
Extreme (50C)	1745	7	0.00401	2.5
Extreme (40C)	1745	15	0.00860	2.5
Extreme (30C)	1745	27	0.01547	2.5
Extreme (10C)	1745	16	0.00917	2.5
Extreme (0C)	1745	21	0.01203	2.5
Extreme (-10C)	1745	14	0.00802	2.5
Extreme (-20C)	1745	7	0.00401	2.5
Extreme (-30C)	1745	24	0.01375	2.5

**\*Note:** Frequency error measurements were made by using the build-in capability of the Wireless Communication Test Set.

## 11. Peak-to-Average Ratio

### 11.1 Description of the PAR Measurement

The peak-to-average ratio (PAR) of the transmission may not exceed 13 dB.

### 11.2 Measuring Instruments

See list of measuring instruments of this test report.

### 11.3 Test Procedures

1. The EUT was connected to Spectrum Analyzer and Base Station via power divider.
2. The RF output of EUT was connected to the spectrum analyzer by RF cable and attenuator. The path loss was compensated to the results for each measurement.
3. For LTE operating modes:
  - a. Set the CCDF (Complementary Cumulative Distribution Function) option in spectrum analyzer.
  - b. The highest RF powers were measured and recorded the maximum PAPR level associated with a probability of 0.1 %.



### 11.4 Test Setup

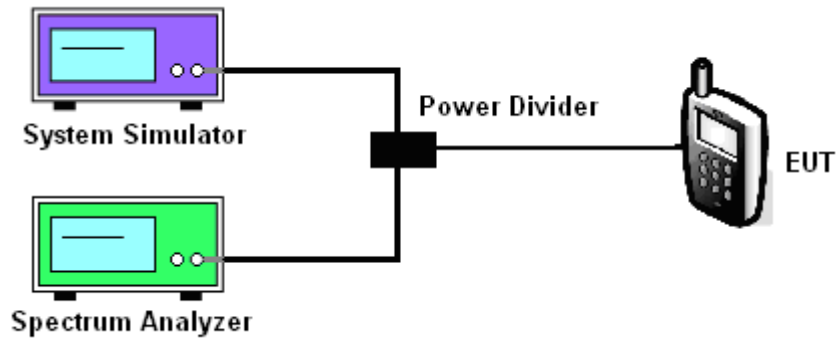

#### MODES TESTED

- LTE Band 2
- LTE Band 4
- LTE Band5
- LTE Band 7
- LTE Band 12
- LTE Band 17
- LTE Band 25,
- LTE Band 26,
- LTE Band 41,
- LTE Band 66

Test data reference attachment.

----END OF REPORT----