

Project : MT6789, LPDDR4X (SBS)  
REF\_SCH TOP LEVEL

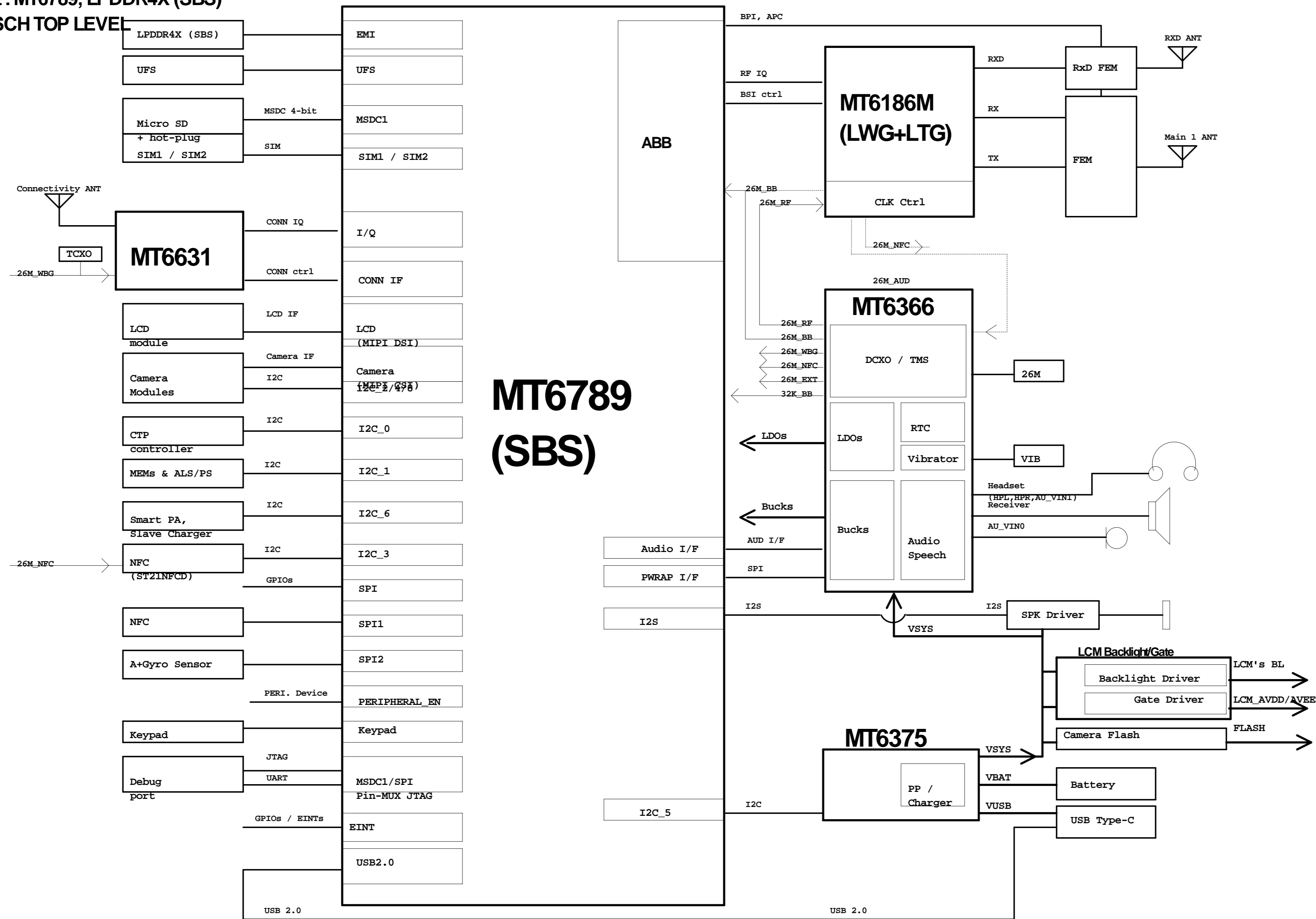

|                                      |       |       |            |                         |  |                           |                |
|--------------------------------------|-------|-------|------------|-------------------------|--|---------------------------|----------------|
| COMPANY: Wheatek Information Systems |       |       |            | MODEL: TE177            |  | Modified Date: 2022/10/21 |                |
| DRAWN                                | WK/SP | DATED | 2022/09/22 | TITLE: 01_BLOCK_DIAGRAM |  | VERSION: V1.1             | SHEET: 1 OF 36 |
| CHECKED                              |       | DATED |            |                         |  |                           |                |
| 4                                    |       |       | 3          |                         |  | 2                         | 1              |

| Date       | Version | Page                         | Change notice  |
|------------|---------|------------------------------|--|
| 2021/12/xx | V0.1    | 10_20_44                     | Modify PDN_cap NC part   |
| 2022/01/xx | V0.2    | 20_POWER_MT6366-Buck         | Remove un-used R2002, R2003 R / 0 / ohm / NC   |
| 2022/01/xx | V0.2    | 44_Memory_UFS_LPDDR4X        | Remove R4401 & R4402 R / 0 / ohm test RES  |
| 2022/01/xx | V0.2    | 13_BB_2_CONN_CSI             | Fixed GPIO100 (HW_ID0), GPIO101 (HW_ID1) txt   |
| 2022/01/xx | V0.2    | 20_21_22                     | Fixed Title name and Note:21-1 IC naming   |
| 2022/01/xx | V0.2    | 81_SYSClk_Clock-26MHz-TSX    | Remove R8107 R / 0 / ohm test RES and Finetune Page81 Schematic design notice  |
| 2022/01/xx | V0.2    | 21_POWER_MT6366-LDO          | Remove C2137 C / 4.7 / uF / 6.3V   |
| 2022/01/xx | V0.2    | 13_BB_2_CONN_CSI             | Add finger print configure   |
| 2022/01/xx | V0.2    | 78_PERI_SENSORS_FingerPrint  | Add finger print configure   |
| 2022/01/xx | V0.2    | 32_RF_MT6186M_RF_TX          | Modify C3299 from C / 10 / uF / 6.3V to C / 4.7 / uF / 6.3V  |
| 2022/01/xx | V0.2    | 68_PERI_CTP                  | Modify VTP_PMU net to VIO28_PMU  |
| 2022/01/xx | V0.2    | 77_PERI_SENSORS_MEMs_ALS/PS  | Modify VLDO28_EXT net to VIO28_PMU   |
| 2022/01/xx | V0.2    | 27_POWER_MT6375-Charger + PP | Change R2705 to R / 0.005/ ohm, HFCL0603MW33R005F  |
| 2022/01/xx | V0.2    | 79_POWER_FLASH_DRIVER        | Change U7901 to U / LM3643YFFR   |
| 2022/01/xx | V0.2    | 13_BB_2_CONN_CSI             | Fixed typo GPIO111 (GPIO_DRDI)   |
| 2022/02/xx | V0.2    | 10_BB_PDN1                   | Change C1033 to C / 2.2 / uF / 6.3V / NC   |
| 2022/02/xx | V0.2    | 11_BB_IOVDD                  | Change C1131 to C / 1 / uF / 6.3V / NC   |
| 2022/02/xx | V0.2    | 82_SYSClk_RTC32K             | Change R8203 to R / 0 / ohm / NC   |
| 2022/02/xx | V0.2    | 27_POWER_MT6375-Charger + PP | Modify MT6375 gauge notic  |
| 2022/02/xx | V0.2    | 21_POWER_MT6366-LDO          | Modify Note 21-1 content   |
| 2022/02/xx | V0.2    | 23_POWER_MainPMIC-Charger    | Change R2304 to R / 4.7 / K  |
| 2022/02/xx | V0.2    | 29_POWER_EXT                 |  |
|            |         |                              | Modify AFVDD/AVDD note   |
| 2022/02/xx | V0.2    | 69_PERI_CAMERA_Rear          | Remove R6906, R6907 and modify C6900 capacitor to C6900, it is recommended to adopt the power architecture (PNC) in Baseband Design Notice, please refer to Camera Power |
| 2022/02/xx | V0.2    | 70_PERI_CAMERA_Front         | Remove R7008, C7012 and modify CON7001 pin 23 to PNC   |
| 2022/02/xx | V0.2    | 77_PERI_SENSORS_MEMs_ALS/PS  | Modify Note, 77-7 Interrupt pin of MEMS sensor must be assign to SCP_EINT  |
| 2022/02/xx | V0.2    | 79_POWER_FLASH_DRIVER        | Remove flash address note  |
| 2022/02/xx | V0.2    | 21_POWER_MT6366-LDO          | Remove R2101 chapter in Baseband Design Notice   |
| 2022/02/xx | V0.2    | 10_BB_PDN1                   | Change C1006, C1007 to NC  |
| 2022/02/xx | V0.2    | 20_POWER_MT6366-Buck         | Change C2033, C2042 to NC  |

|                                  |       |       |            |                                |                                  |                       |
|----------------------------------|-------|-------|------------|--------------------------------|----------------------------------|-----------------------|
| COMPANY: <b>Wheatek Inc./華泰盛</b> |       |       |            | MODEL: <b>TE177</b>            | Modified Date: <b>2022/10/21</b> |                       |
| DRAWN                            | WK/SP | DATED | 2022/09/22 | TITLE: <b>02_CHANGE_NOTICE</b> | VERSION: <b>V1.1</b>             | SHEET: <b>2 OF 36</b> |
| CHECKED                          |       | DATED |            |                                |                                  |                       |
| 4                                |       | 3     |            | 2                              |                                  | 1                     |





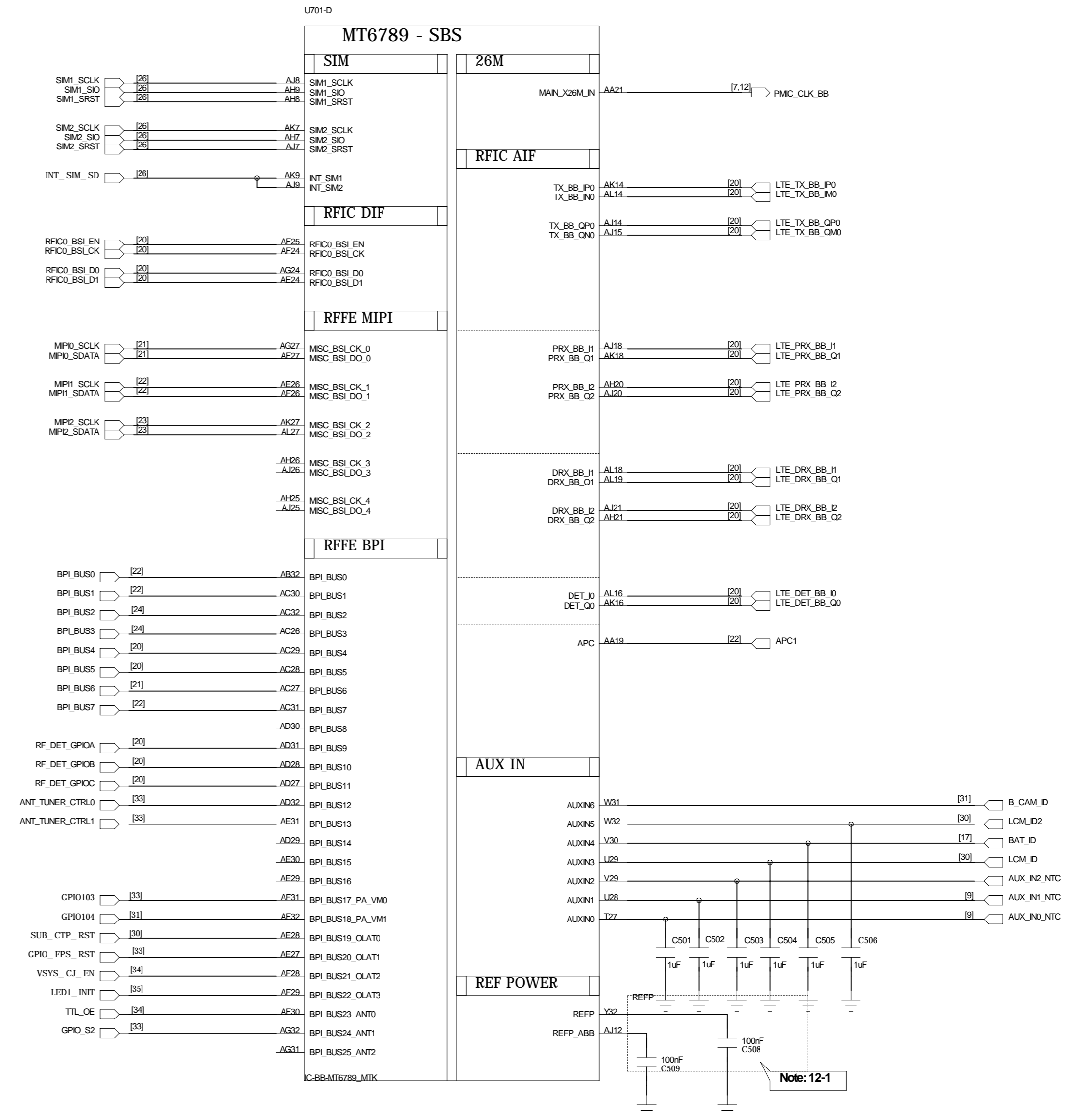
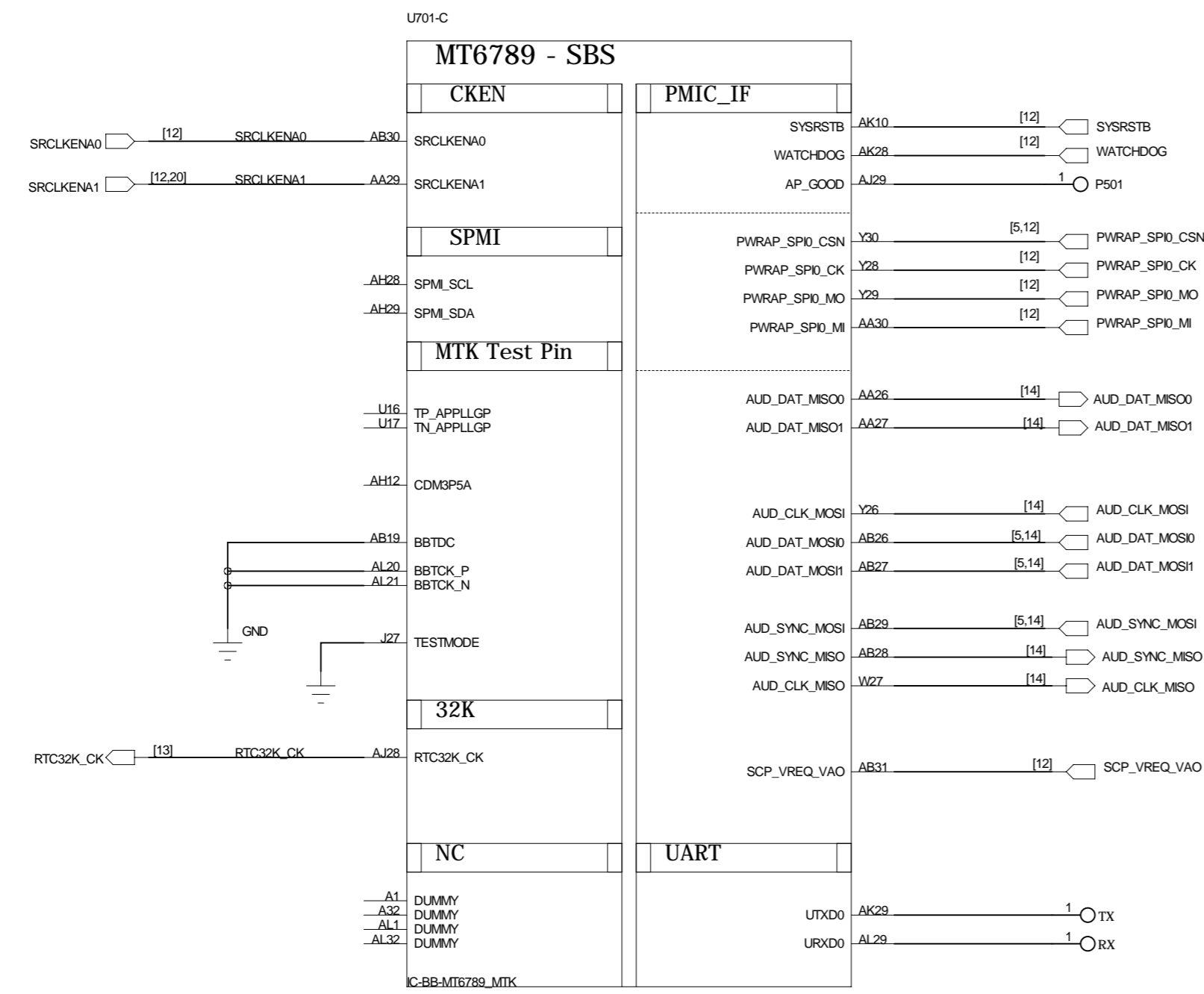

**Schematic design notice of "12\_BB\_1" page:**

Note 12-1: The de-coupling cap. for REFP have to be placed as close to BB as possible.

Note 12-2: "PWRAP\_SPI0\_CSN" and "AUD\_DAT\_MOSI0" pin features in trapping pin to enable JTAG.

| PWRAP_SPI0_CSN        | AUD_DAT_MOSI0         | AP JTAG Mode                                       | IO JTAG Mode                                       |
|-----------------------|-----------------------|--|--|
| H (Default)           | L (Default)           | N/A  | N/A  |
| H                     | H<br>(by external PU) | SPI6_CSB, SPI6_CLK,<br>SPI6_MO, SPI6_MI,<br>EINT13 | N/A  |
| L<br>(by external PD) | L                     | SPI6_CSB, SPI6_CLK,<br>SPI6_MO, SPI6_MI,<br>EINT13 | SPI1_CSB, SPI1_CLK,<br>SPI1_MO, SPI1_MI,<br>EINT14 |
| L<br>(by external PD) | H<br>(by external PU) | SPI6_CSB, SPI6_CLK,<br>SPI6_MO, SPI6_MI,<br>EINT13 | SPI1_CSB, SPI1_CLK,<br>SPI1_MO, SPI1_MI,<br>EINT14 |

Note 12-3: "AUD\_SYNC\_MOSI" pin features in trapping pin to booting (UFS/eMMC).

| AUD_SYNC_MOSI         | Storage Booting Mode |
|-----------------------|----------------------|
| L (Default)           | Only UFS boot        |
| H<br>(by external PU) | Only eMMC boot       |

Note 12-4 "AUD\_DAT\_MOSI1" pin features in trapping pin for SW co-load.

| AUD_DAT_MOSI1         | Mode          |
|-----------------------|---------------|
| L (Default)           | LP4x-MCP      |
| H<br>(by external PU) | LP4x-Discrete |

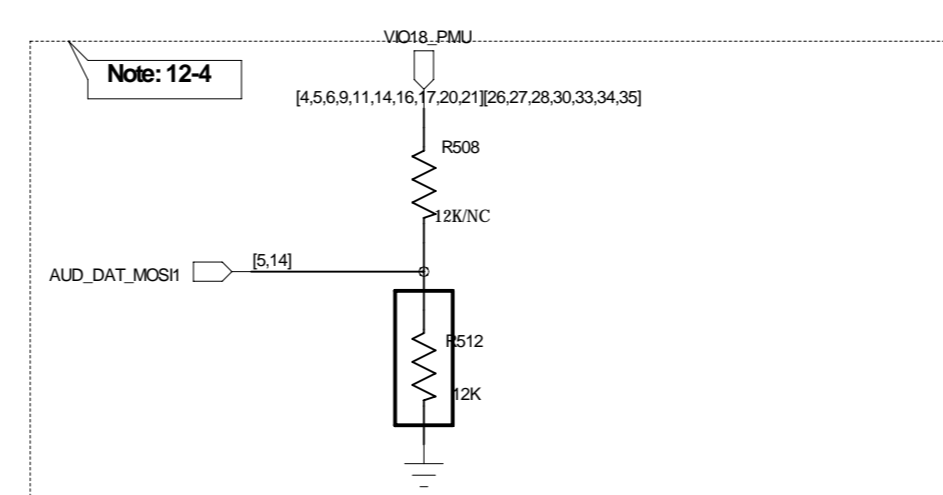
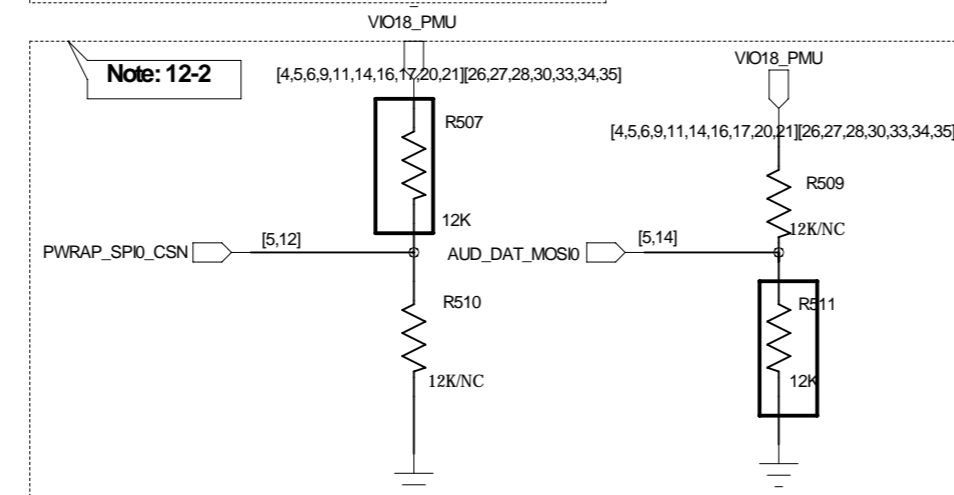
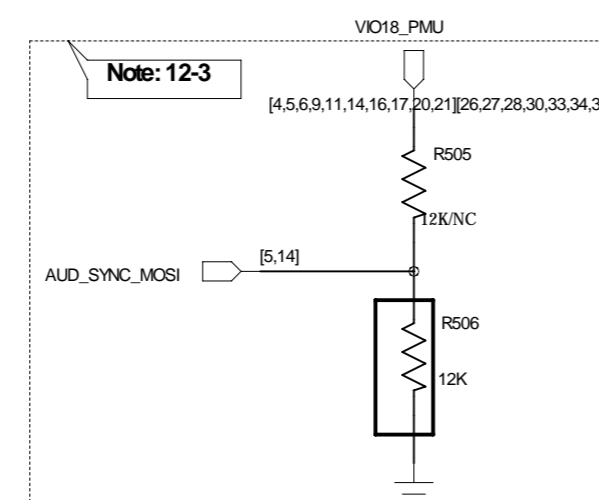

|                       |       |       |            |                       |  |                                  |                       |
|-----------------------|-------|-------|------------|-----------------------|--|----------------------------------|-----------------------|
| COMPANY: <b>Watek</b> |       |       |            | MODEL: <b>TE177</b>   |  | Modified Date: <b>2022/10/21</b> |                       |
| DRAWN                 | WK/SP | DATED | 2022/09/22 | TITLE: <b>05_BB_1</b> |  | VERSION: <b>V1.1</b>             | SHEET: <b>5 OF 36</b> |
| CHECKED               |       | DATED |            |                       |  |                                  |                       |



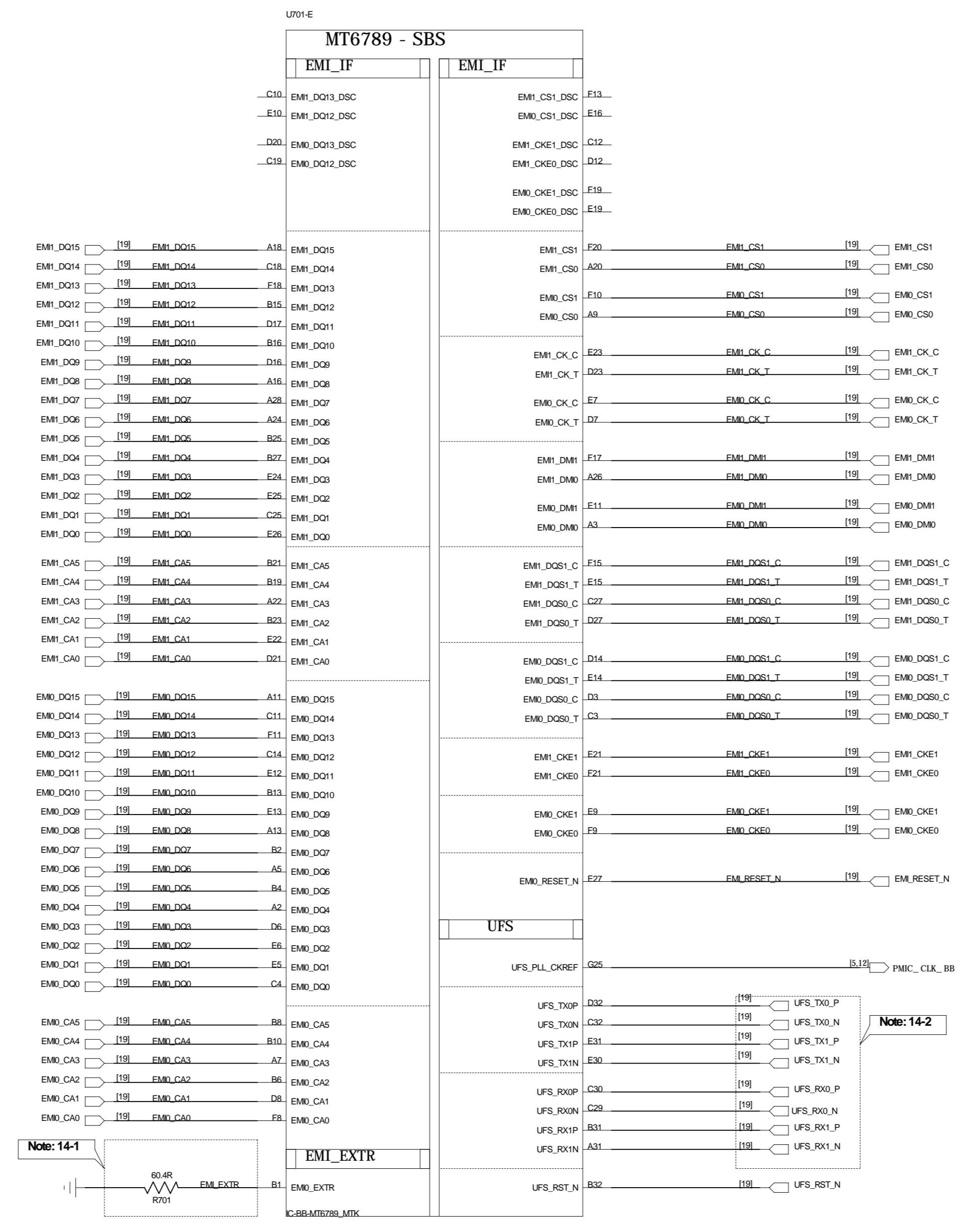

**Schematic design notice of "14\_BB\_3\_Interface" page:**

Note 14-1: R4001 please select 60.4 ohm (1%) resistor

Note 14-2: Make sure TX/RX connection (T to in, R to out and P to t, N to c)

|                         |       |       |            |                     |                           |                |
|-------------------------|-------|-------|------------|---------------------|---------------------------|----------------|
| COMPANY: <b>Wheatek</b> |       |       |            | MODEL: <b>TE177</b> | Modified Date: 2022/10/21 |                |
| DRAWN                   | WK/SP | DATED | 2022/09/22 | TITLE: 07_BB_3      |                           | VERSION: V1.1  |
| CHECKED                 |       | DATED |            |                     |                           | SHEET: 7 OF 36 |
| 4                       |       | 3     |            | 2                   |                           | 1              |

Schematic design notice of "16\_BB\_AUXADC" page.

|                 | AUX_IN2 (RF SKU/PCB ID)                                     |                               |
|-----------------|---|-------------------------------|
| SKU1 EU+CHN+JPN | (ADC range is 0.05~1.45V)<br>0.05V 0V(R1604=NC, R1606=100K) |                               |
| SKU2 NA         | 0.21V   | 0.21V(R1604=750K, R1606=100K) |
| Reserved        | 0.42V   | 0.41V(R1604=330K, R1606=100K) |
| Reserved        | 0.62V   | 0.62V(R1604=191K, R1606=100K) |
| Reserved        | 0.82V   | 0.82V(R1604=120K, R1606=100K) |
| Reserved        | 1.04V   | 0.99V(R1604=100K, R1606=137K) |
| Reserved        | 1.24V   | 1.24V(R1604=100K, R1606=220K) |
| Reserved        | 1.45V   | 1.45V(R1604=100K, R1606=422K) |

|                                    |       |       |            |                     |                           |                |
|------------------------------------|-------|-------|------------|---------------------|---------------------------|----------------|
| COMPANY: <b>Wheatek</b> 禾泰科技股份有限公司 |       |       |            | MODEL: <b>TE177</b> | Modified Date: 2022/10/21 |                |
| DRAWN                              | WK/SP | DATED | 2022/09/22 | TITLE: 08_BB_AUXADC | VERSION: V1.1             | SHEET: 8 OF 36 |
| CHECKED                            |       | DATED |            |                     |                           |                |
| 4                                  |       | 3     |            | 2                   |                           | 1              |



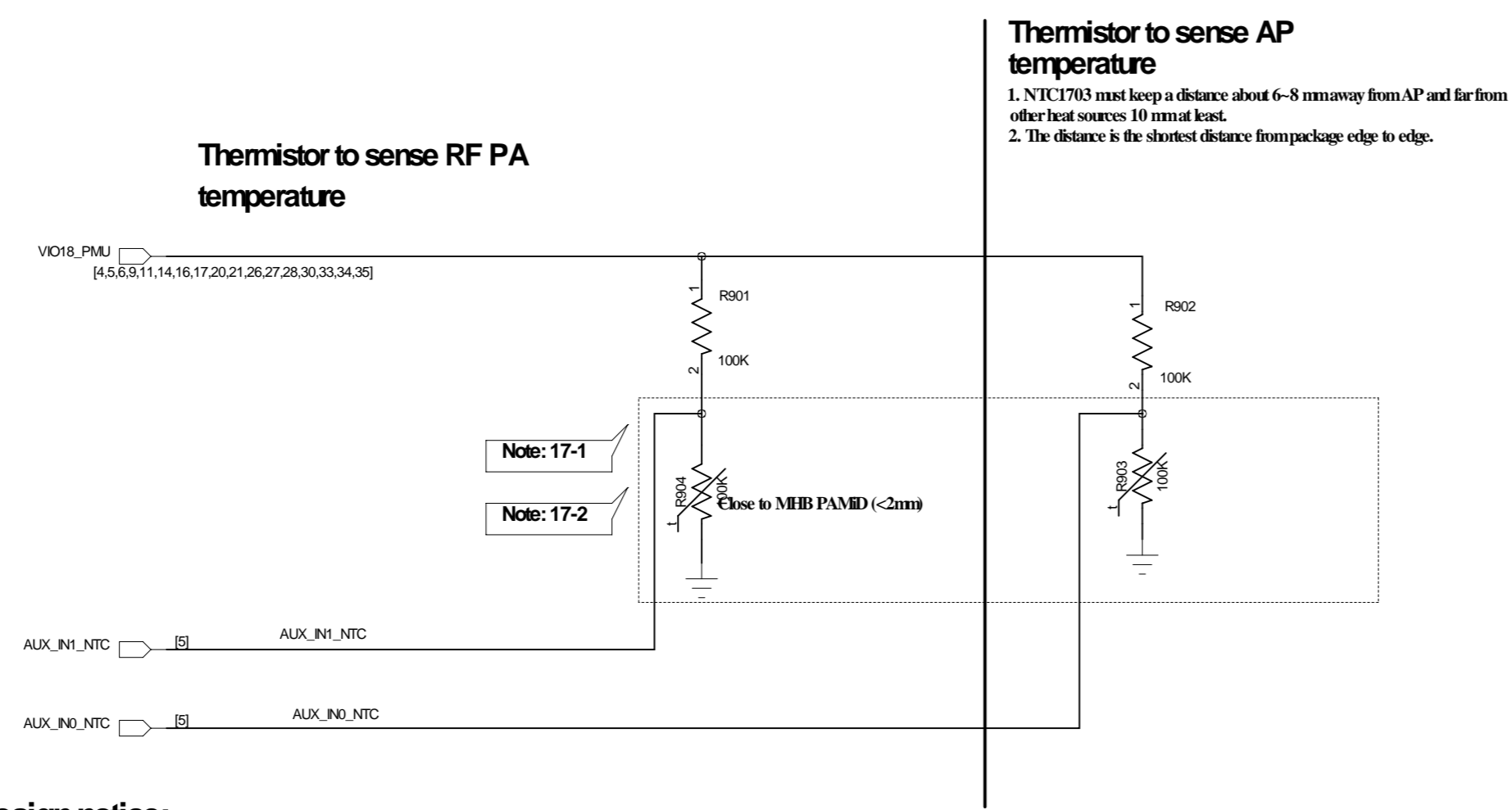

**Thermistor to sense AP temperature**  
 1. NTC1703 must keep a distance about 6-8 mm away from AP and far from other heat sources 10 mm at least.  
 2. The distance is the shortest distance from package edge to edge.

**RAMDUMP debug key**

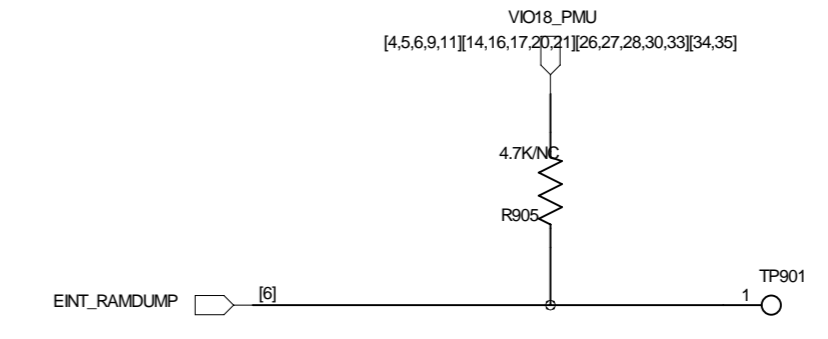

**Schematic design notice:**

Note 17-1: SW Default Configuration is as follows  
 AUX\_IN0\_NTC is for AP Temp.  
 AUX\_IN1\_NTC is for MHB PAMD Temp.  
 Note 17-2: If your design or placement is different with SW Default Config.  
 Please refer to "MTXXXX Thermal User Manual.docx" and modify SW setting.

|                                     |       |       |            |                                    |  |                                  |                       |
|-------------------------------------|-------|-------|------------|------------------------------------|--|----------------------------------|-----------------------|
| COMPANY: <b>Wheatek Electronics</b> |       |       |            | MODEL: <b>TE177</b>                |  | Modified Date: <b>2022/10/21</b> |                       |
| DRAWN                               | WK/SP | DATED | 2022/09/22 | TITLE: <b>09_BB_AUXADC_THERMAL</b> |  | VERSION: <b>V1.1</b>             | SHEET: <b>9 OF 36</b> |
| CHECKED                             |       | DATED |            |                                    |  |                                  |                       |
| 4                                   |       | 3     |            | 2                                  |  | 1                                |                       |

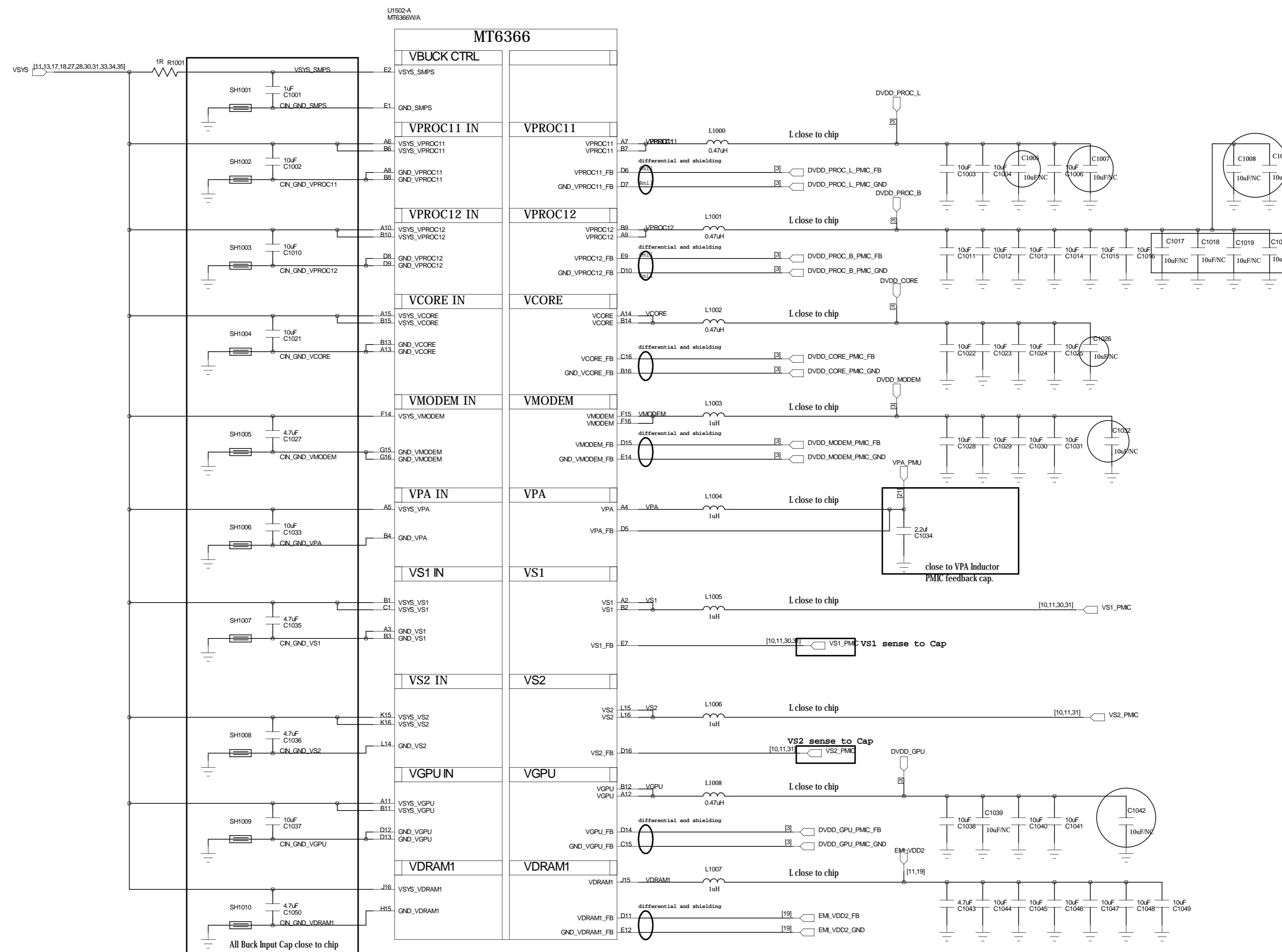

|                                     |       |       |            |                                    |  |                                  |                        |
|-------------------------------------|-------|-------|------------|------------------------------------|--|----------------------------------|------------------------|
| COMPANY: <b>Wheatek Inc. (AMEV)</b> |       |       |            | MODEL: <b>TE177</b>                |  | Modified Date: <b>2022/10/21</b> |                        |
| DRAWN                               | WK/SP | DATED | 2022/09/22 | TITLE: <b>10_POWER_MT6366-BUCK</b> |  | VERSION: <b>V1.1</b>             | SHEET: <b>10 OF 36</b> |
| CHECKED                             |       | DATED |            |                                    |  |                                  |                        |

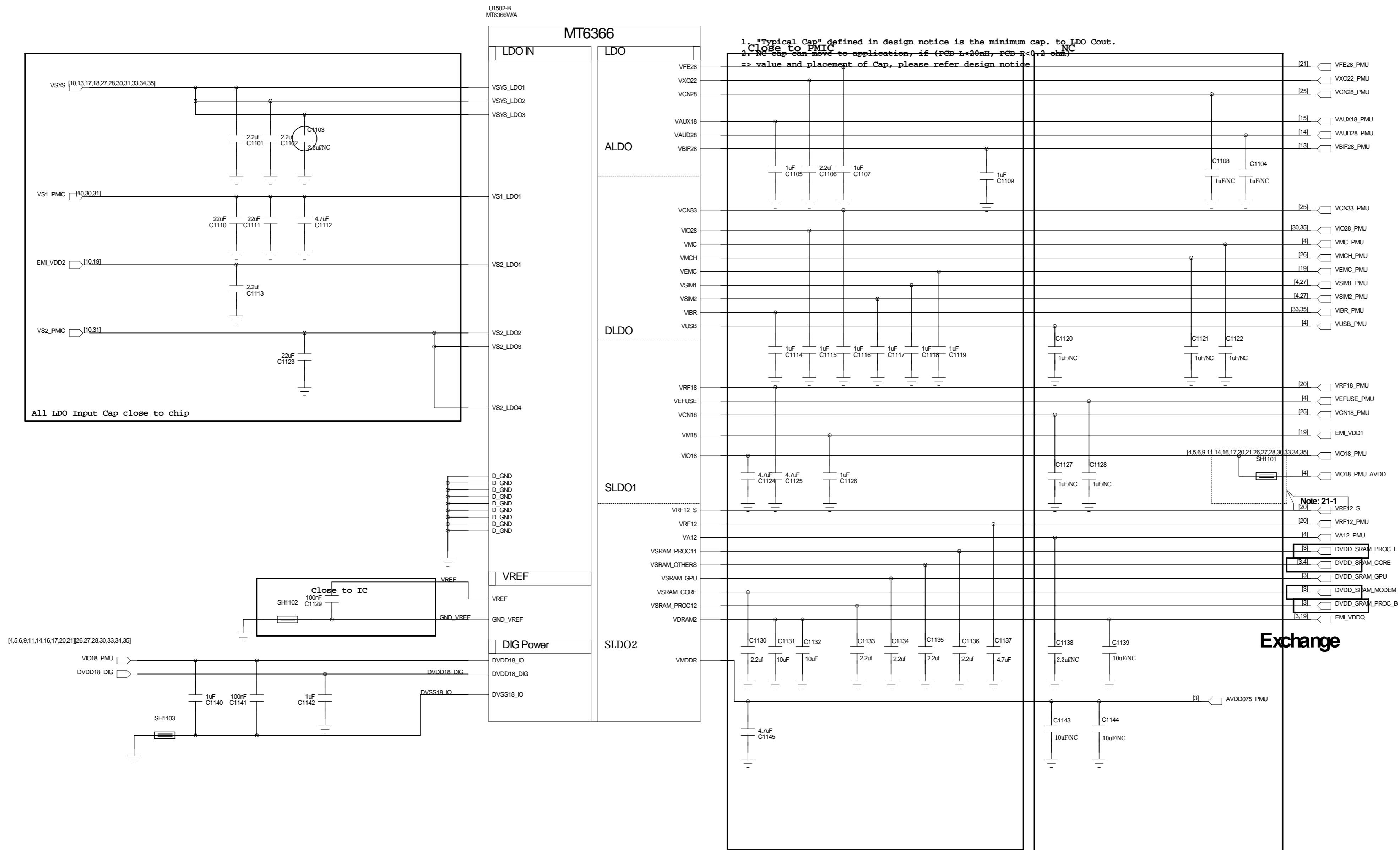

Schematic design notice of "21\_POWER\_MT6366-LDO" page.

Note 21-1: Please set SH2101 close to C2132, making star connection between VIO18\_PMU and VIO18\_PMU\_AVDD near to LDO cap. C2132  
Please also refer to MT6366 design notice for further detail design information

|                             |       |       |            |                                   |  |                                  |                        |
|-----------------------------|-------|-------|------------|-----------------------------------|--|----------------------------------|------------------------|
| COMPANY: <b>Wheatek 威泰克</b> |       |       |            | MODEL: <b>TE177</b>               |  | Modified Date: <b>2022/10/21</b> |                        |
| DRAWN                       | WK/SP | DATED | 2022/09/22 | TITLE: <b>11_POWER_MT6366-LDO</b> |  | VERSION: <b>V1.1</b>             | SHEET: <b>11 OF 36</b> |
| CHECKED                     |       | DATED |            |                                   |  |                                  |                        |
| 4                           |       | 3     |            | 2                                 |  |                                  | 1                      |

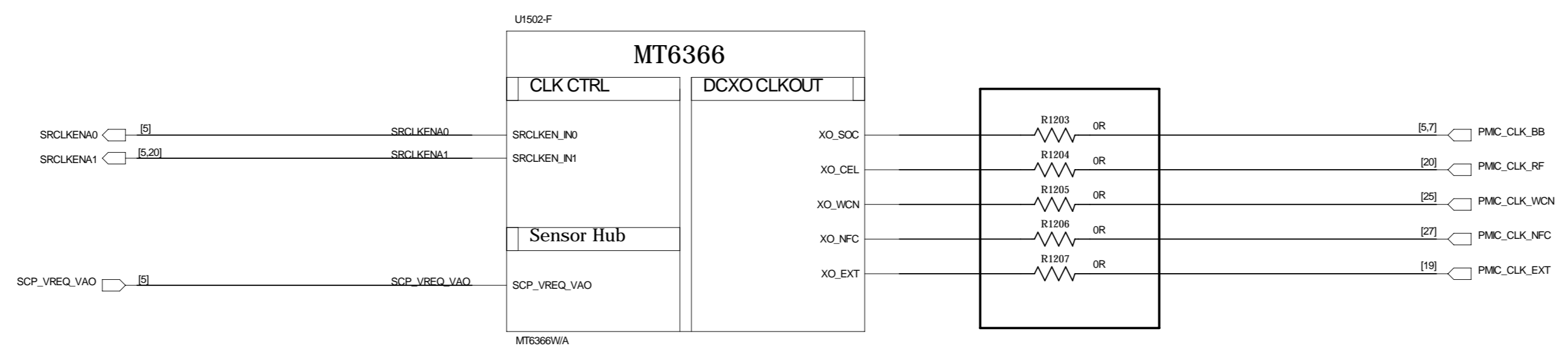
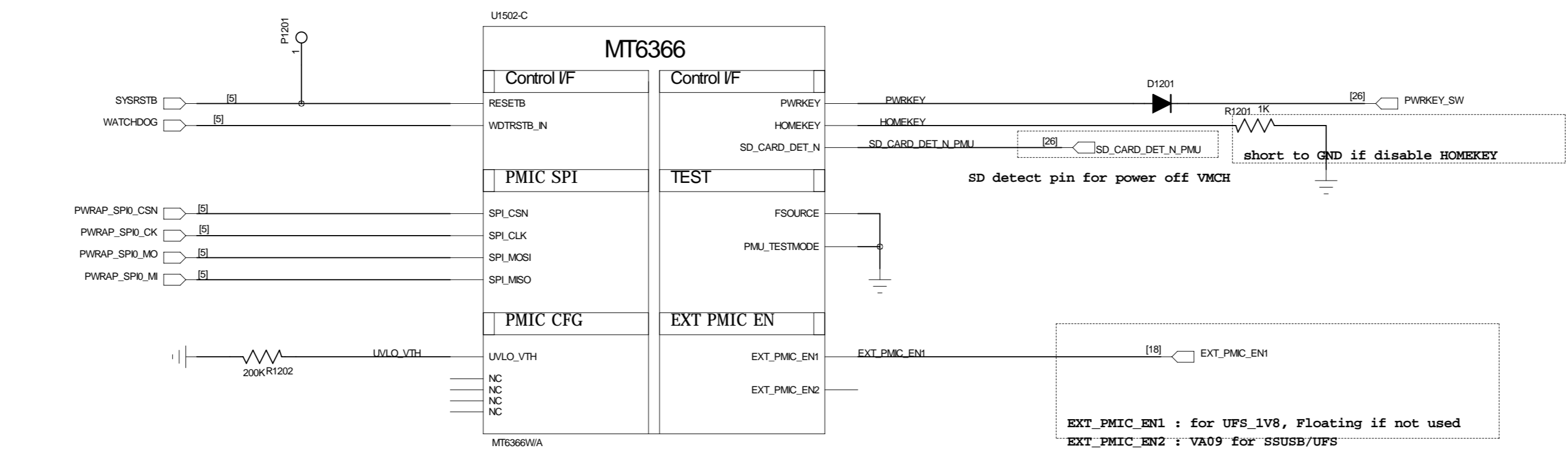

|                                    |       |       |            |                                |                           |                 |
|------------------------------------|-------|-------|------------|--------------------------------|---------------------------|-----------------|
| COMPANY: <b>Wheatek Inc. / 艾特克</b> |       |       |            | MODEL: <b>TE177</b>            | Modified Date: 2022/10/21 |                 |
| DRAWN                              | WK/SP | DATED | 2022/09/22 | TITLE: 12_POWER_MT6366-GENERAL |                           | VERSION: V1.1   |
| CHECKED                            |       | DATED |            |                                |                           | SHEET: 12 OF 36 |
| 4                                  |       | 3     |            | 2                              |                           | 1               |

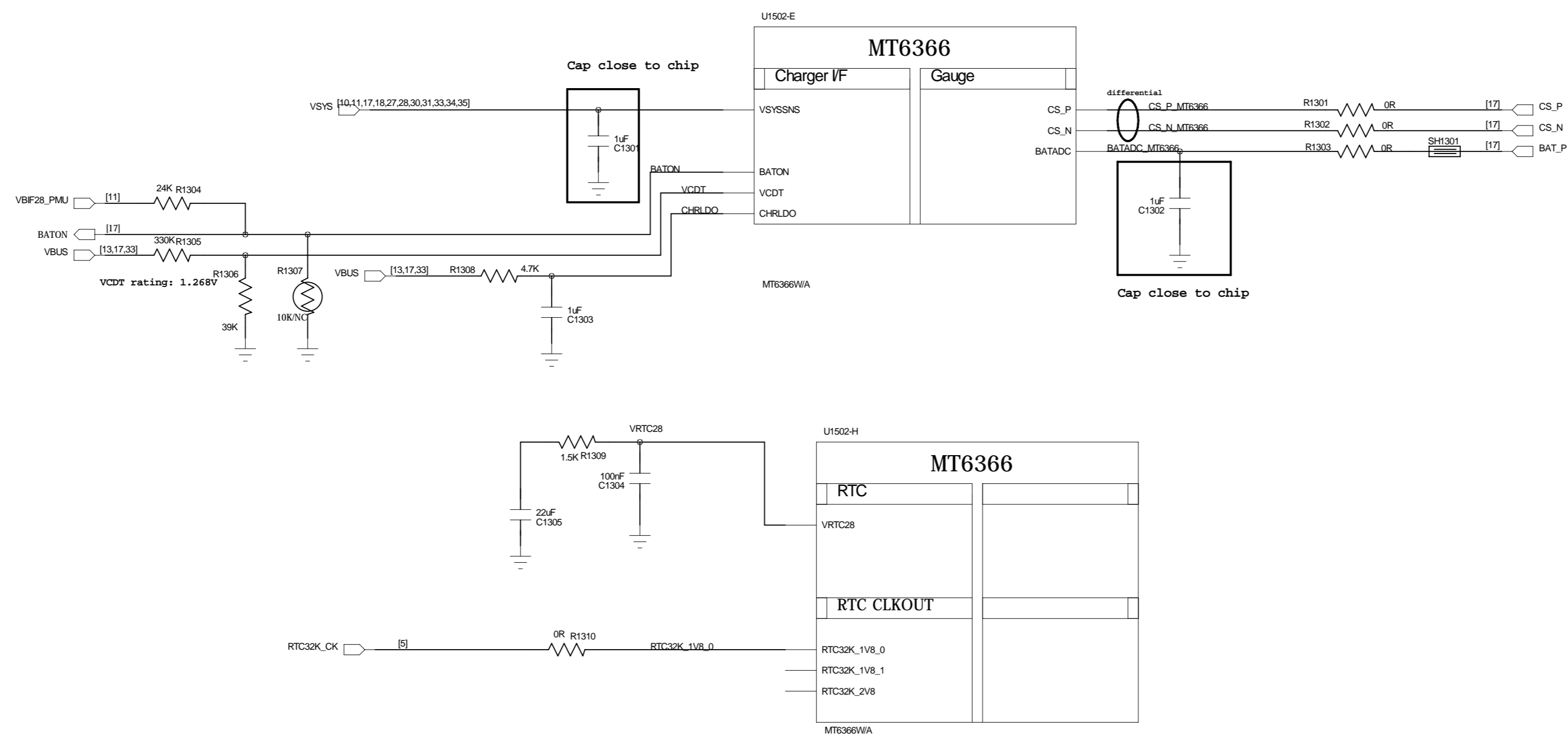

Schematic design notice of "23\_POWER\_MainPMIC-Charger" page:

|                                    |       |       |            |                                |                           |                 |
|------------------------------------|-------|-------|------------|--------------------------------|---------------------------|-----------------|
| COMPANY: <b>Wheatek Inc. / 艾特威</b> |       |       |            | MODEL: <b>TE177</b>            | Modified Date: 2022/10/21 |                 |
| DRAWN                              | WK/SP | DATED | 2022/09/22 | TITLE: 13_POWER_MT6366-CHARGER |                           | VERSION: V1.1   |
| CHECKED                            |       | DATED |            |                                |                           | SHEET: 13 OF 36 |

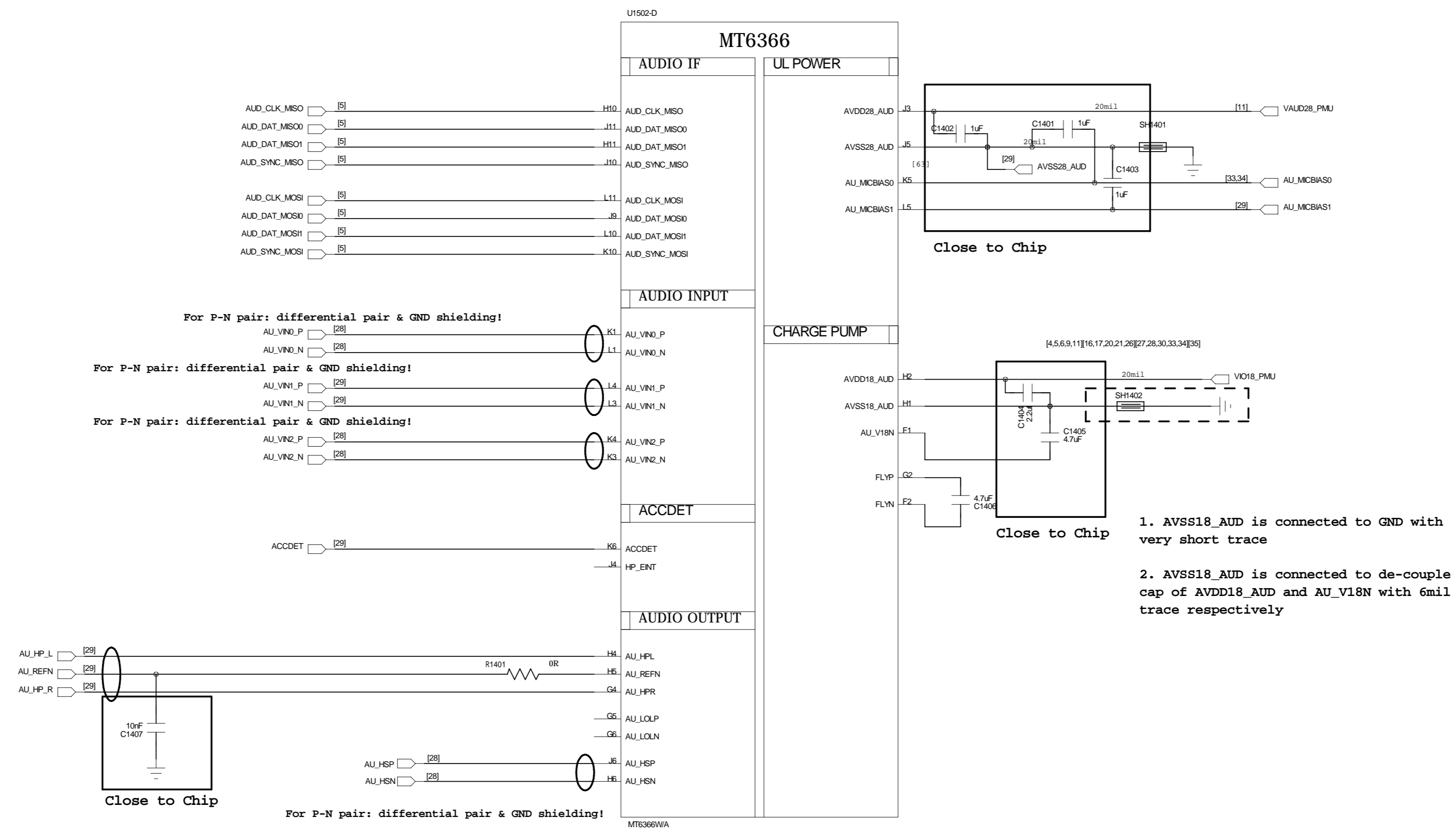

|                                      |       |       |            |                                     |  |                                  |                        |
|--------------------------------------|-------|-------|------------|-------------------------------------|--|----------------------------------|------------------------|
| COMPANY: <b>Wheatek Inc. / TE177</b> |       |       |            | MODEL: <b>TE177</b>                 |  | Modified Date: <b>2022/10/21</b> |                        |
| DRAWN                                | WK/SP | DATED | 2022/09/22 | TITLE: <b>14_POWER_MT6366-AUDIO</b> |  | VERSION: <b>V1.1</b>             | SHEET: <b>14 OF 36</b> |
| CHECKED                              |       | DATED |            |                                     |  |                                  |                        |
| 4                                    |       | 3     |            | 2                                   |  | 1                                |                        |

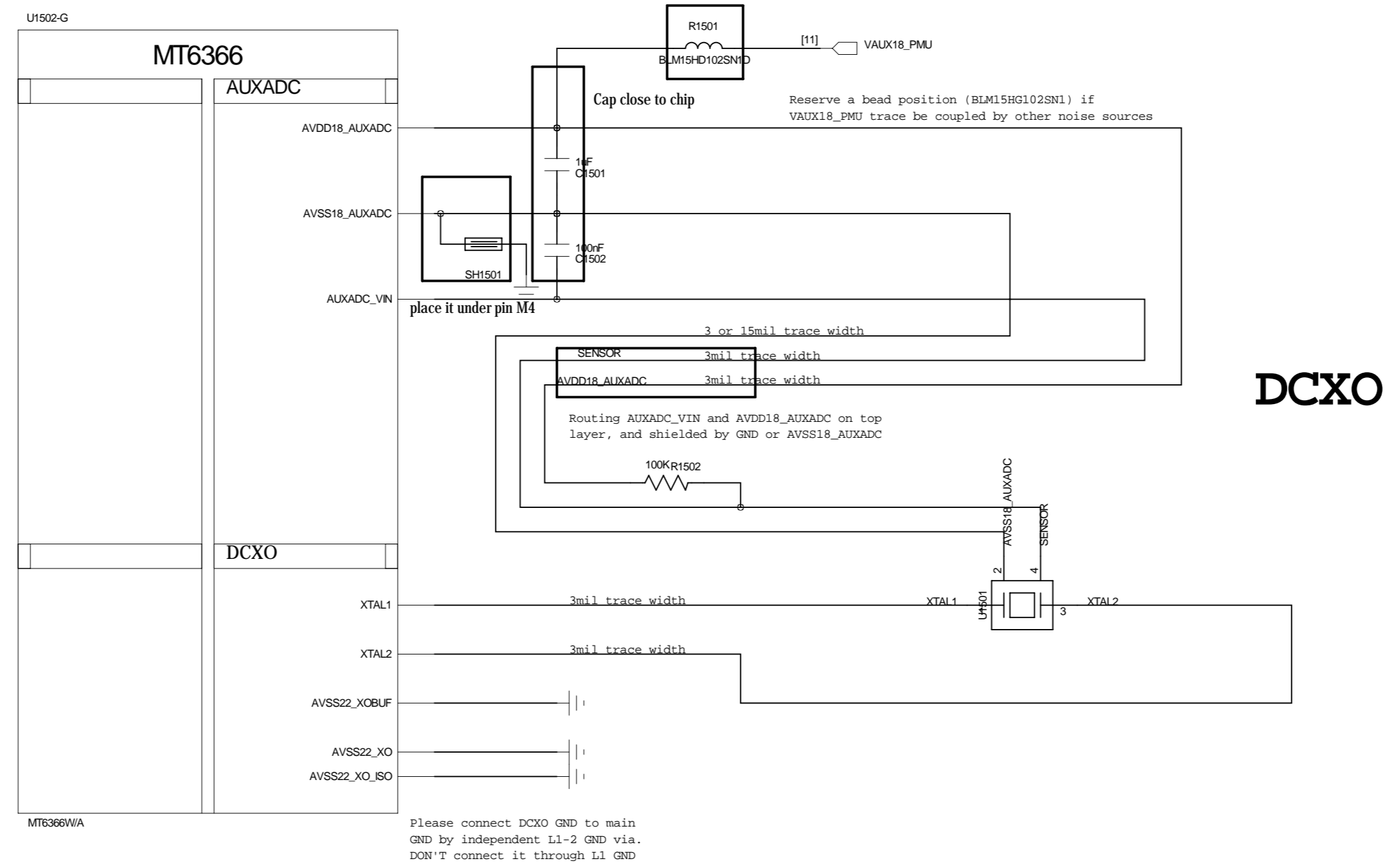

Schematic design notice of "81\_SYCLK\_Clock-26MHz-TSX" page:

Route AVDD18\_AUXADC/AUXADC\_VIN as differential trace (3 mil each) with well GND shielding and route AVSS18\_AUXADC with 15mil trace width under AVDD18\_AUXADC/AUXADC\_VIN trace to provide return current path.

|                                     |       |       |            |                              |                           |
|-------------------------------------|-------|-------|------------|------------------------------|---------------------------|
| COMPANY: Wheatek Corp. / 瑞泰科技股份有限公司 |       |       |            | MODEL: TE177                 | Modified Date: 2022/10/21 |
| DRAWN                               | WK/SP | DATED | 2022/09/22 | TITLE: 15_POWER_MT6366_CLOCK | VERSION: V1.1             |
| CHECKED                             |       | DATED |            |                              | SHEET: 15 OF 36           |

# CC Logic

HUSB311 I2C:0x4Eor 0x3E

HUSB311 R1610 0R; RT1715 4.7K

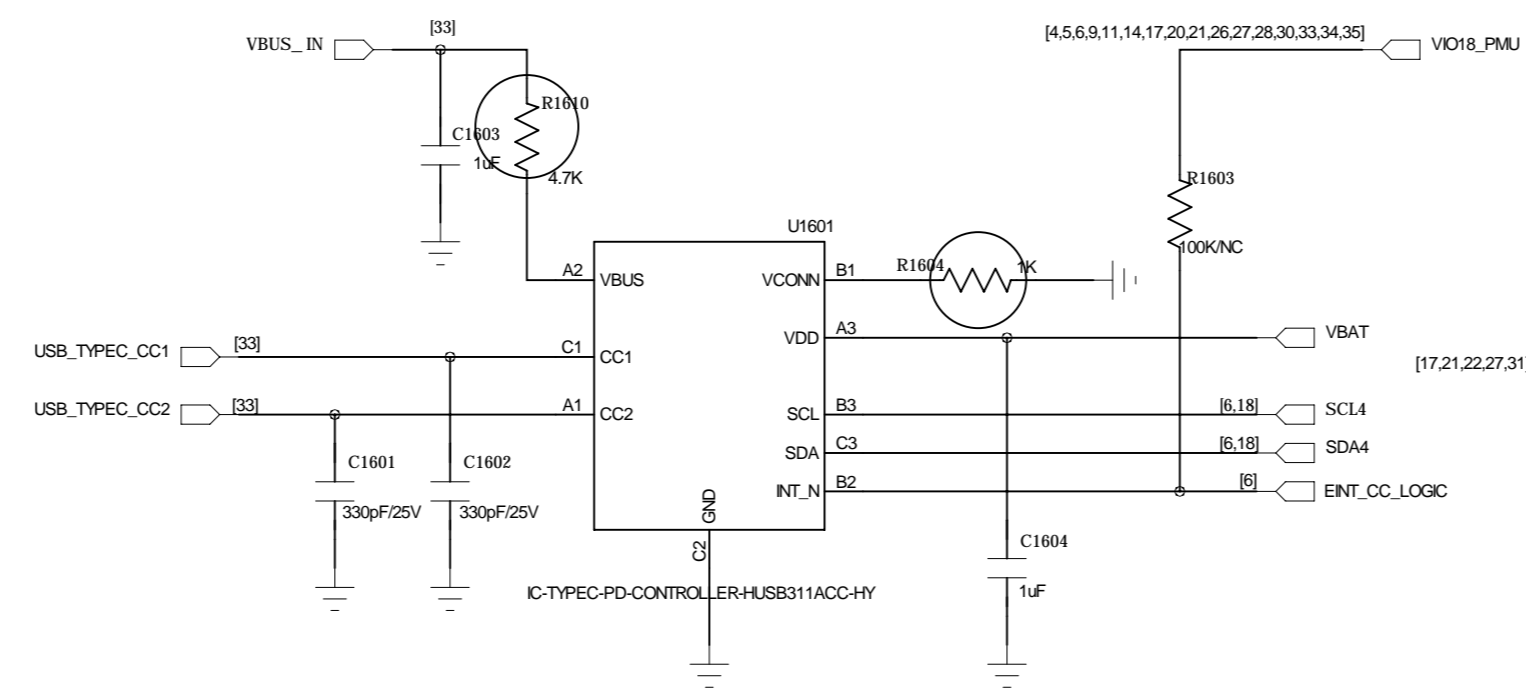

|   |       |       |            |                                  |                                  |
|---|-------|-------|------------|----------------------------------|----------------------------------|
| COMPANY: <b>Wheatek Information Systems</b> |       |       |            | MODEL: <b>TE177</b>              | Modified Date: <b>2022/10/21</b> |
| DRAWN                                       | WK/SP | DATED | 2022/09/22 | TITLE: <b>16_POWER_MT6375-IF</b> | VERSION: <b>V1.1</b>             |
| CHECKED                                     |       | DATED |            |                                  | SHEET: <b>16 OF 36</b>           |





# LCM Backlight LED Driver

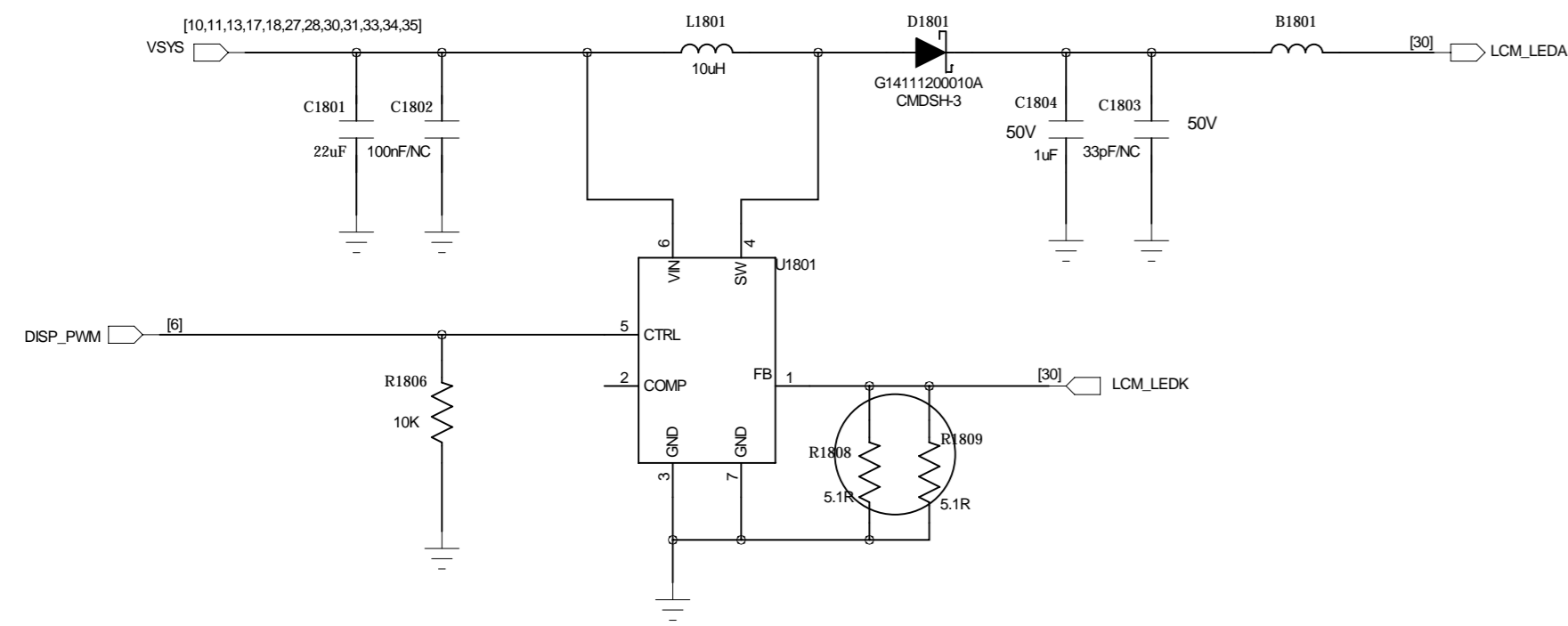

# EXT VUFS18 for UFS

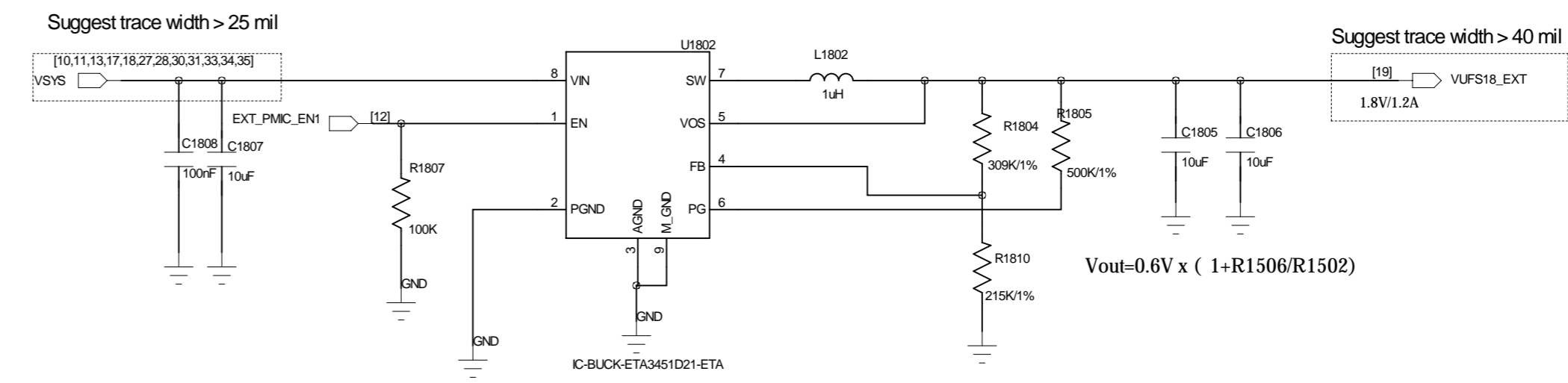

# LCM Gate Drive

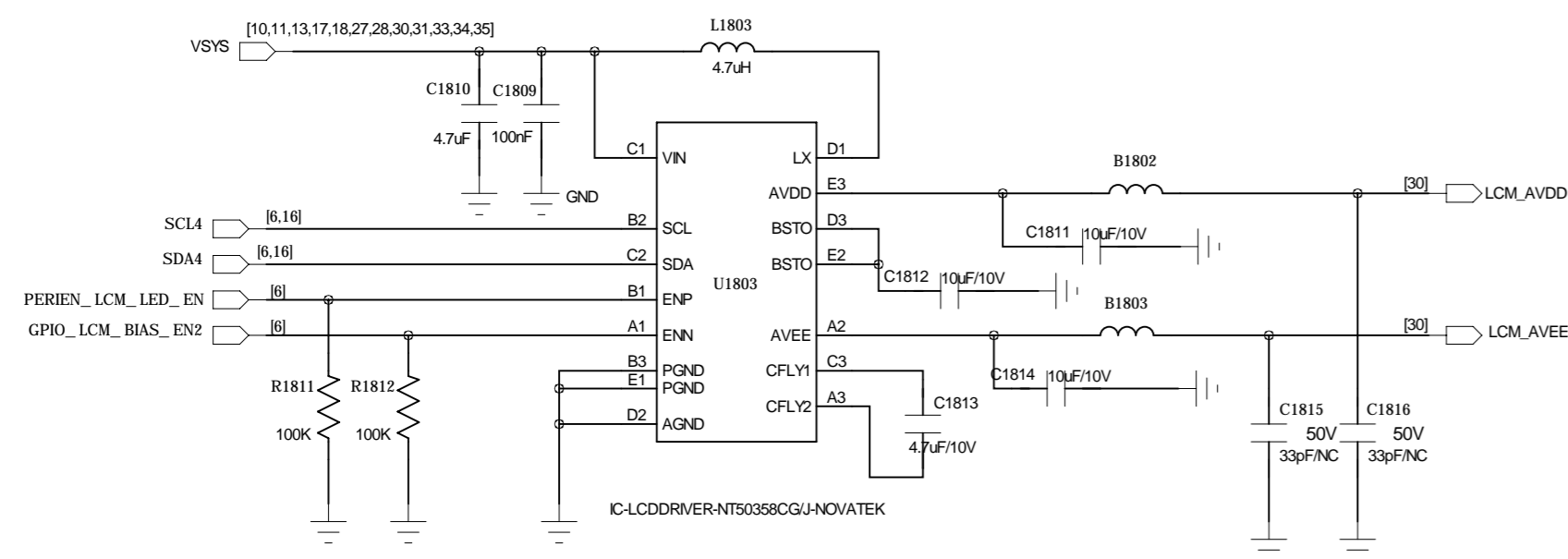

NT50358CG/J2C ADDRESS:0x3EH(Write:0x7C,Read:0x7D)

|                                     |       |       |            |                            |  |                                  |                        |
|-------------------------------------|-------|-------|------------|----------------------------|--|----------------------------------|------------------------|
| COMPANY: <b>Wheatek Electronics</b> |       |       |            | MODEL: <b>TE177</b>        |  | Modified Date: <b>2022/10/21</b> |                        |
| DRAWN                               | WK/SP | DATED | 2022/09/22 | TITLE: <b>18_POWER_EXT</b> |  | VERSION: <b>V1.1</b>             | SHEET: <b>18 OF 36</b> |
| CHECKED                             |       | DATED |            |                            |  |                                  |                        |



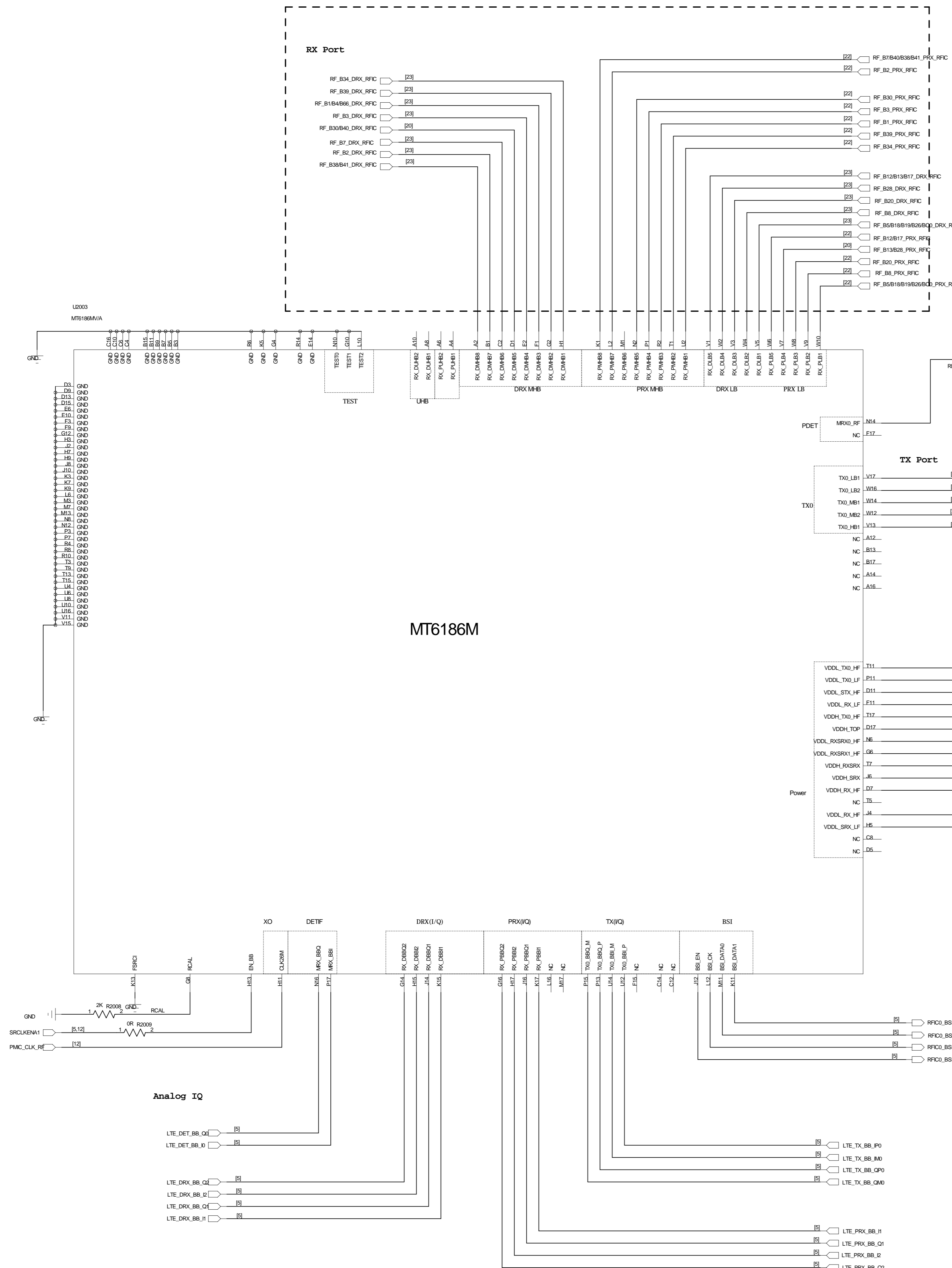

MT6186M

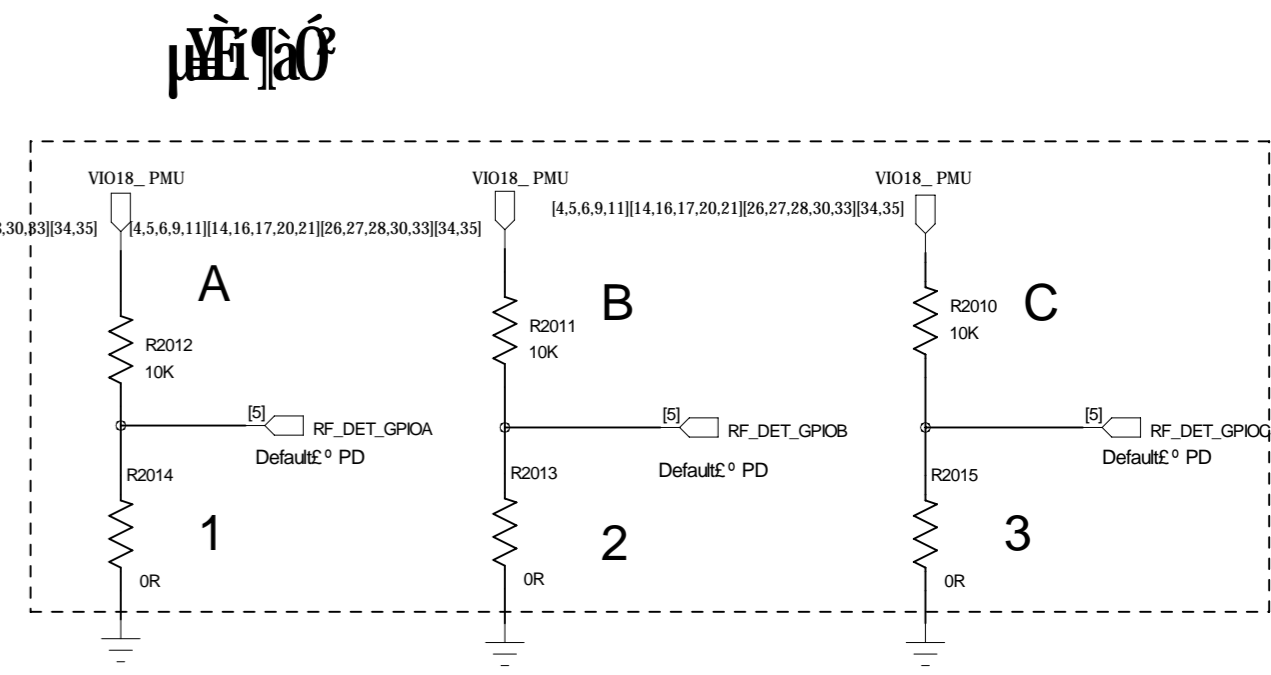
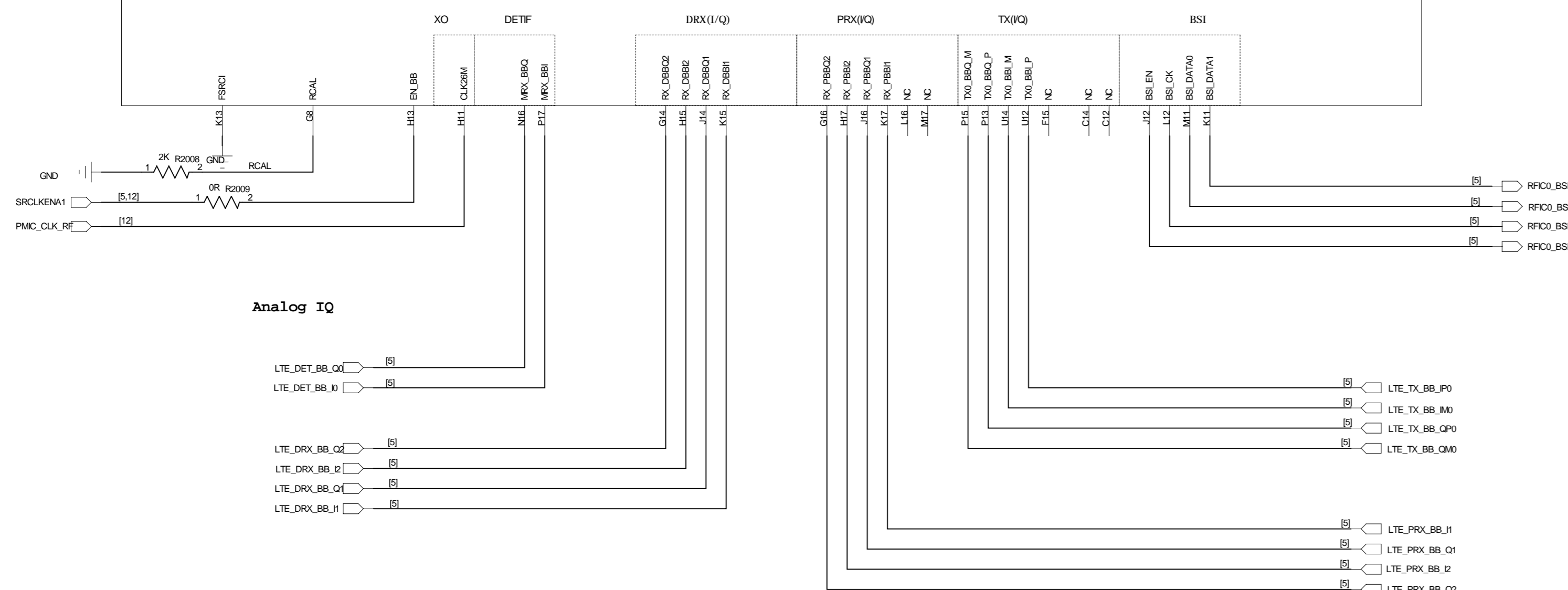
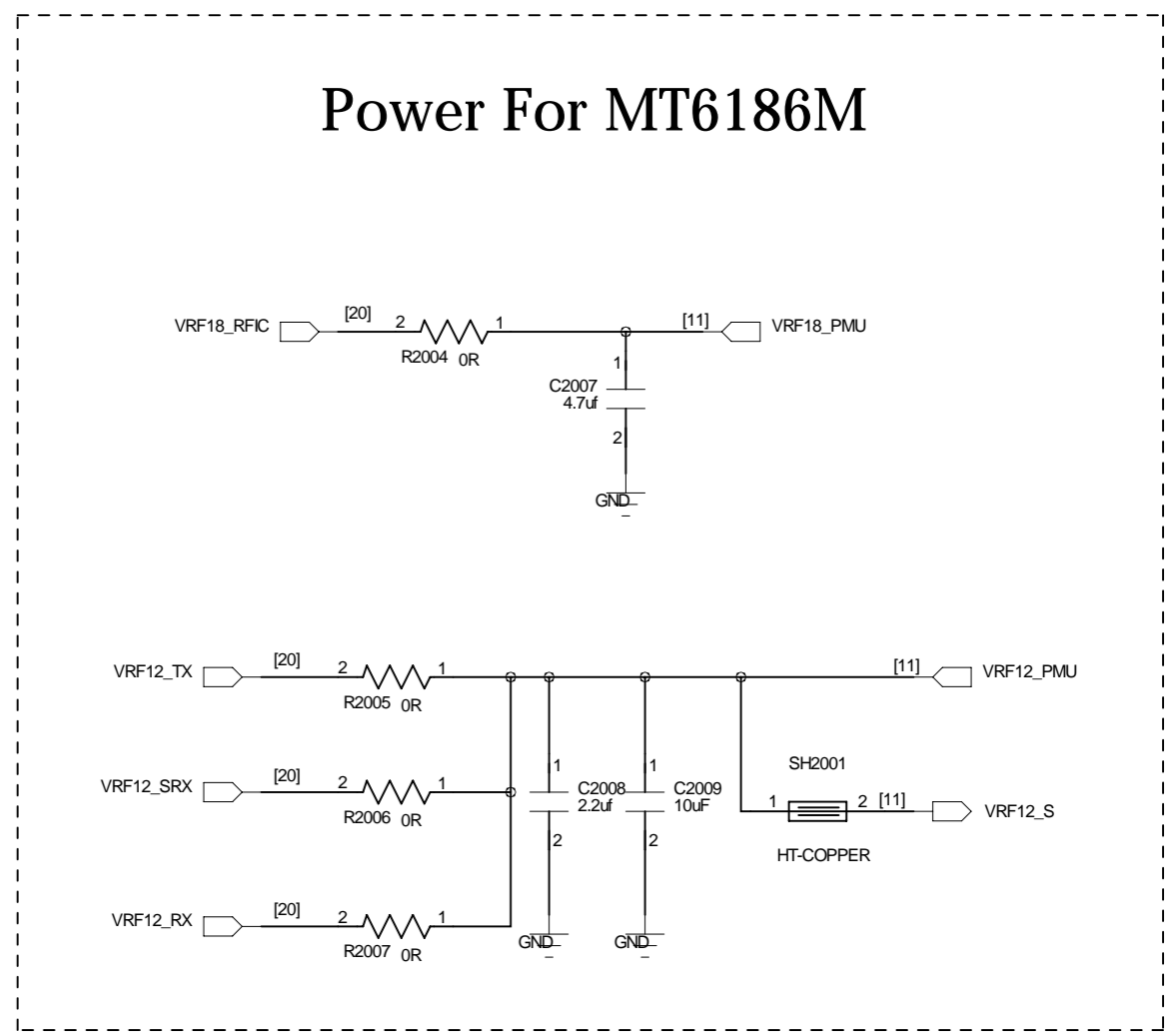
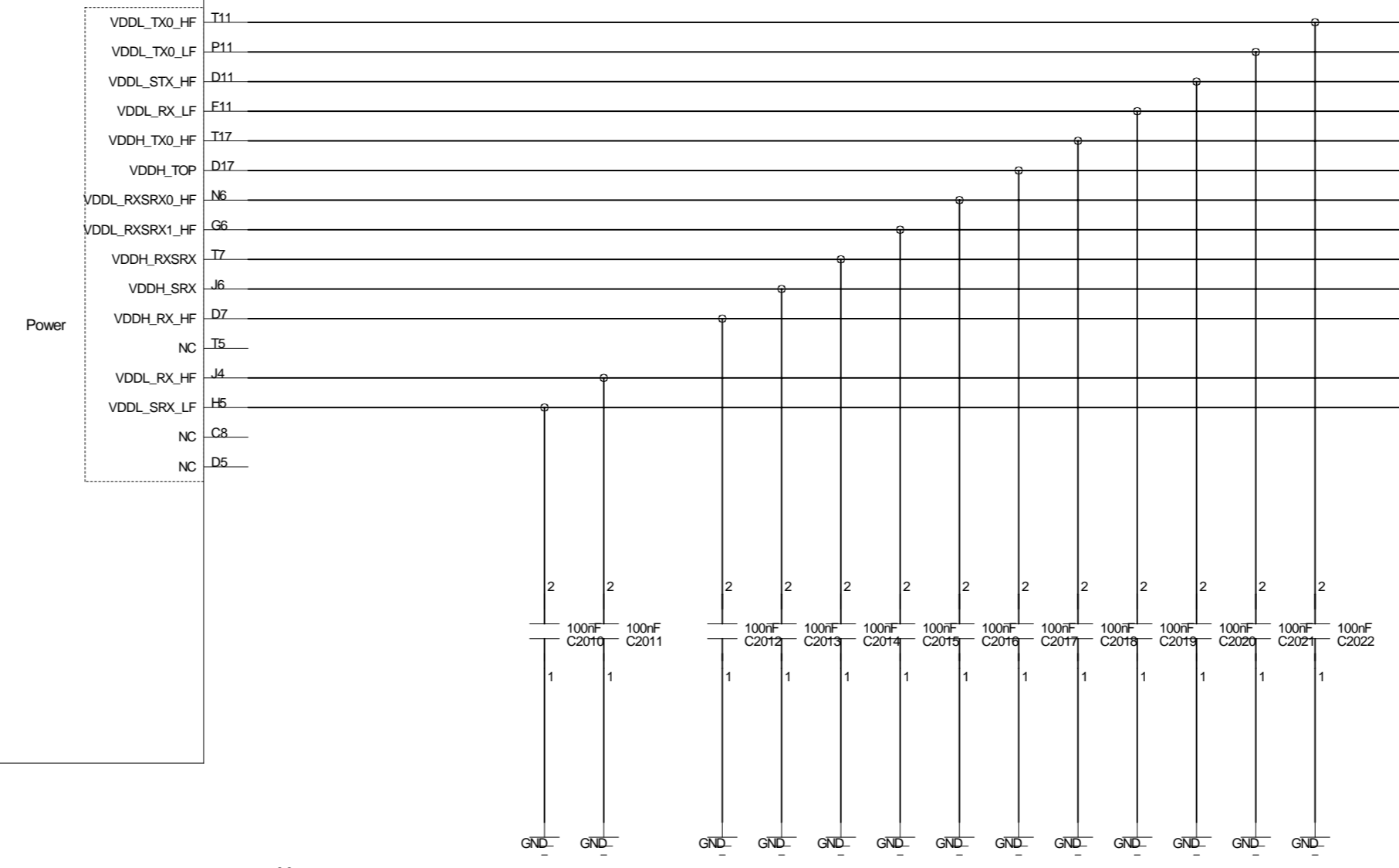
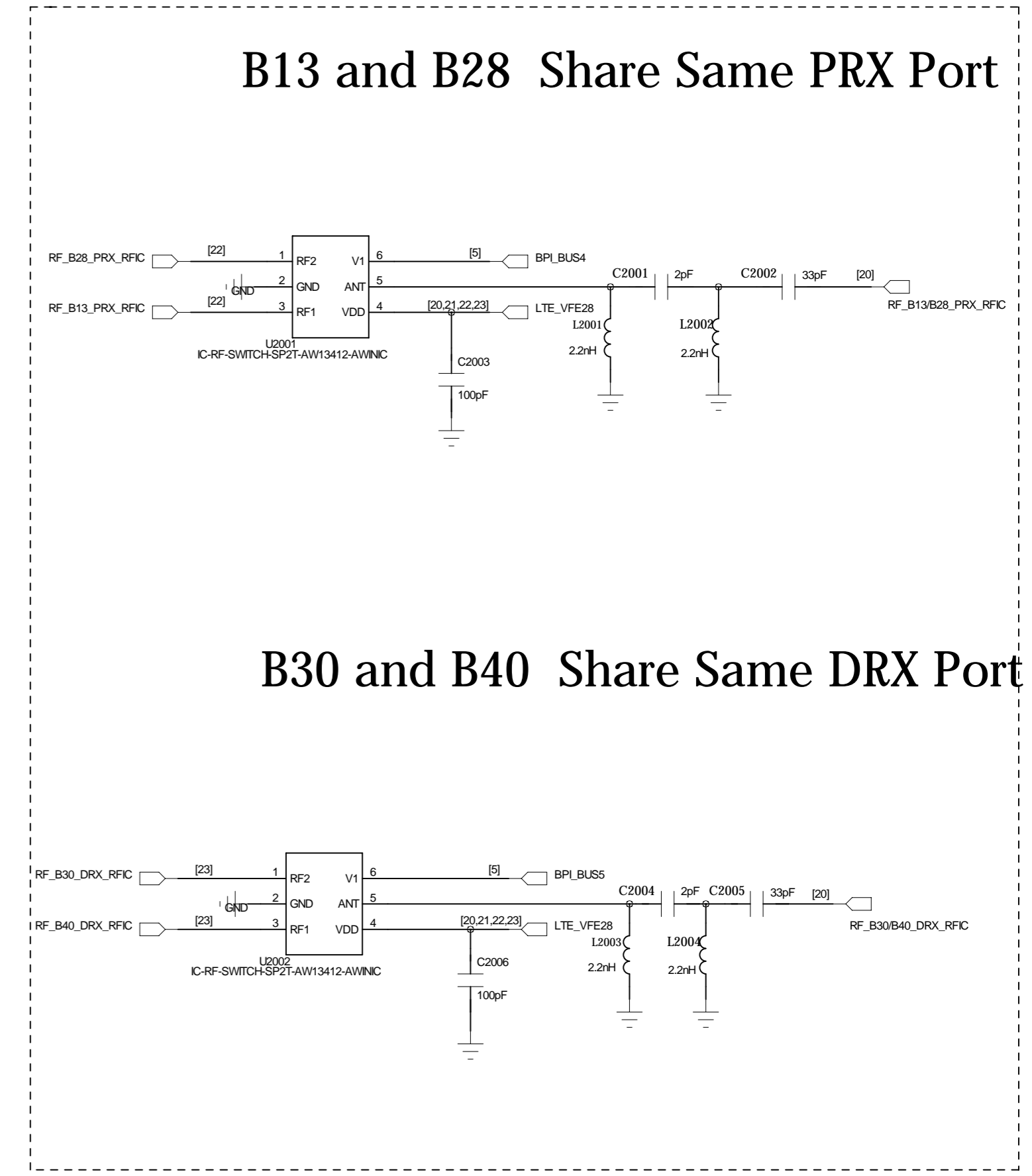

|                         |       |       |            |                                     |  |                                  |                        |
|-------------------------|-------|-------|------------|-------------------------------------|--|----------------------------------|------------------------|
| COMPANY: <b>Wheatek</b> |       |       |            | MODEL: <b>TE177</b>                 |  | Modified Date: <b>2022/10/21</b> |                        |
| DRAWN                   | WK/SP | DATED | 2022/09/22 | TITLE: <b>20_RF_MT6186M_PIN_OUT</b> |  | VERSION: <b>V1.1</b>             | SHEET: <b>20 OF 36</b> |
| CHECKED                 |       | DATED |            |                                     |  |                                  |                        |

# Power Net Connection

PA Power Trace Width  
 VPA\_VCC1: 10mil  
 VPA\_PMU: 40mil  
 VBAT: 60mil

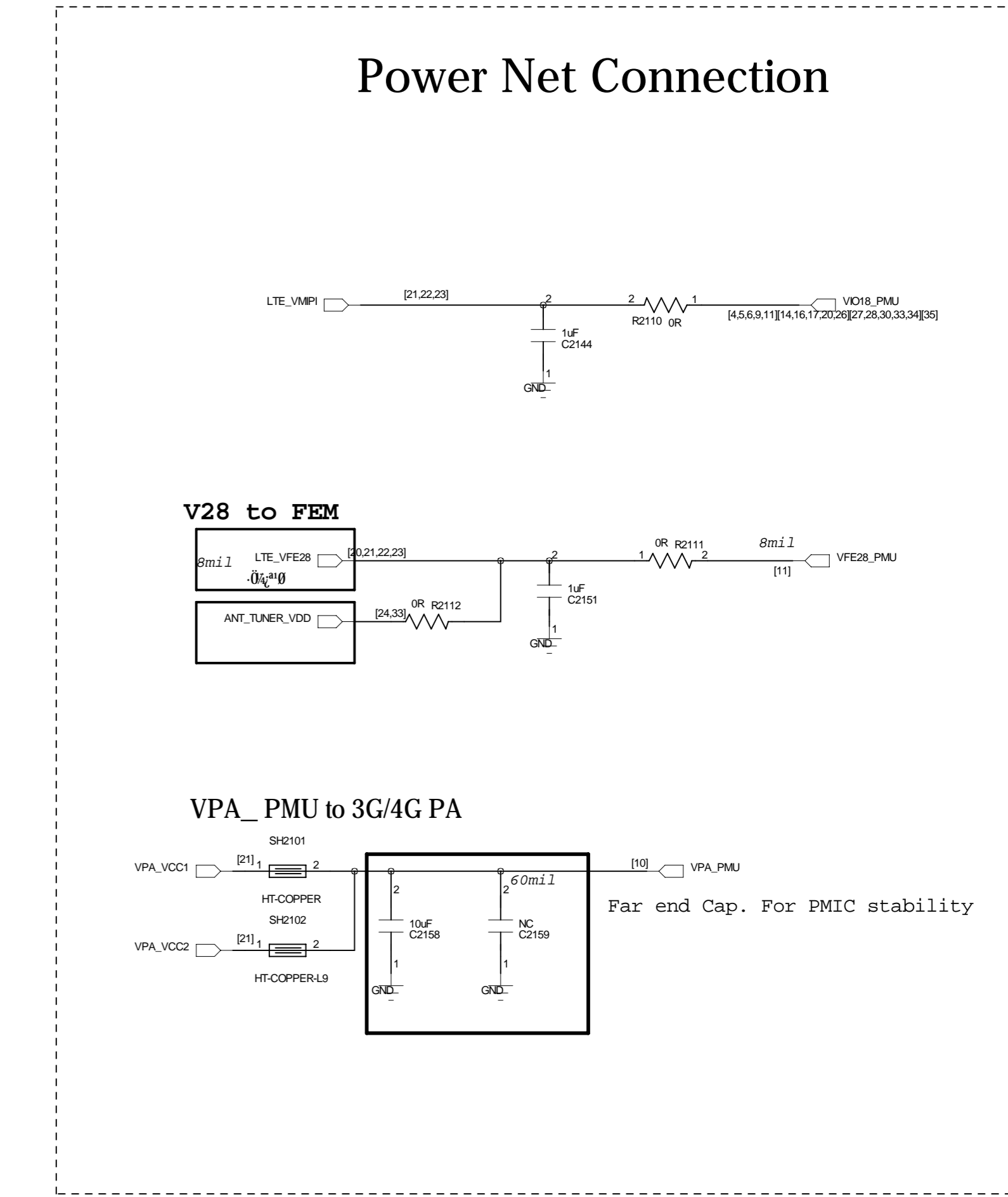
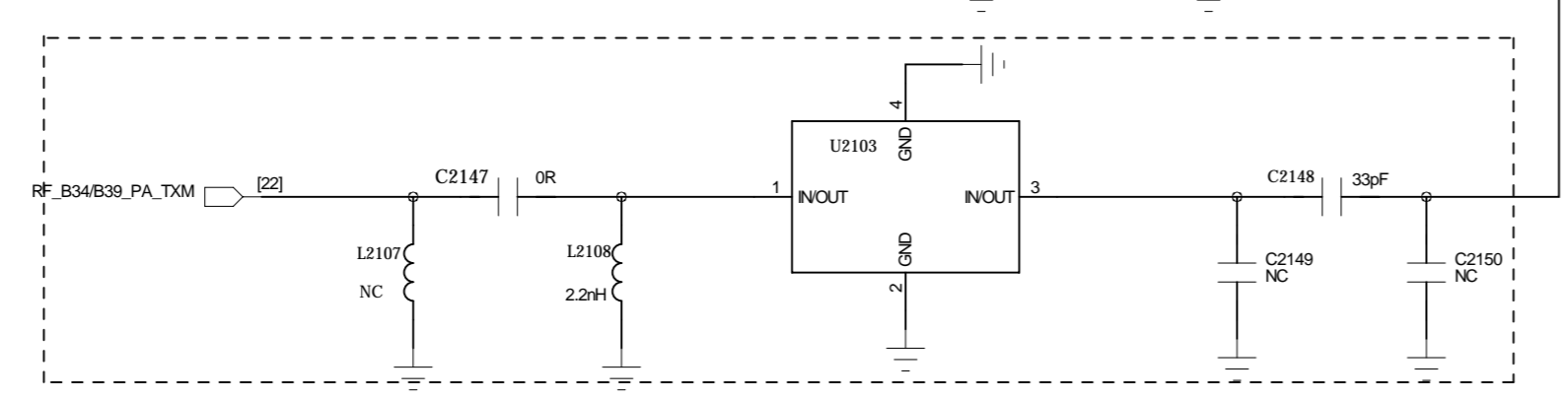
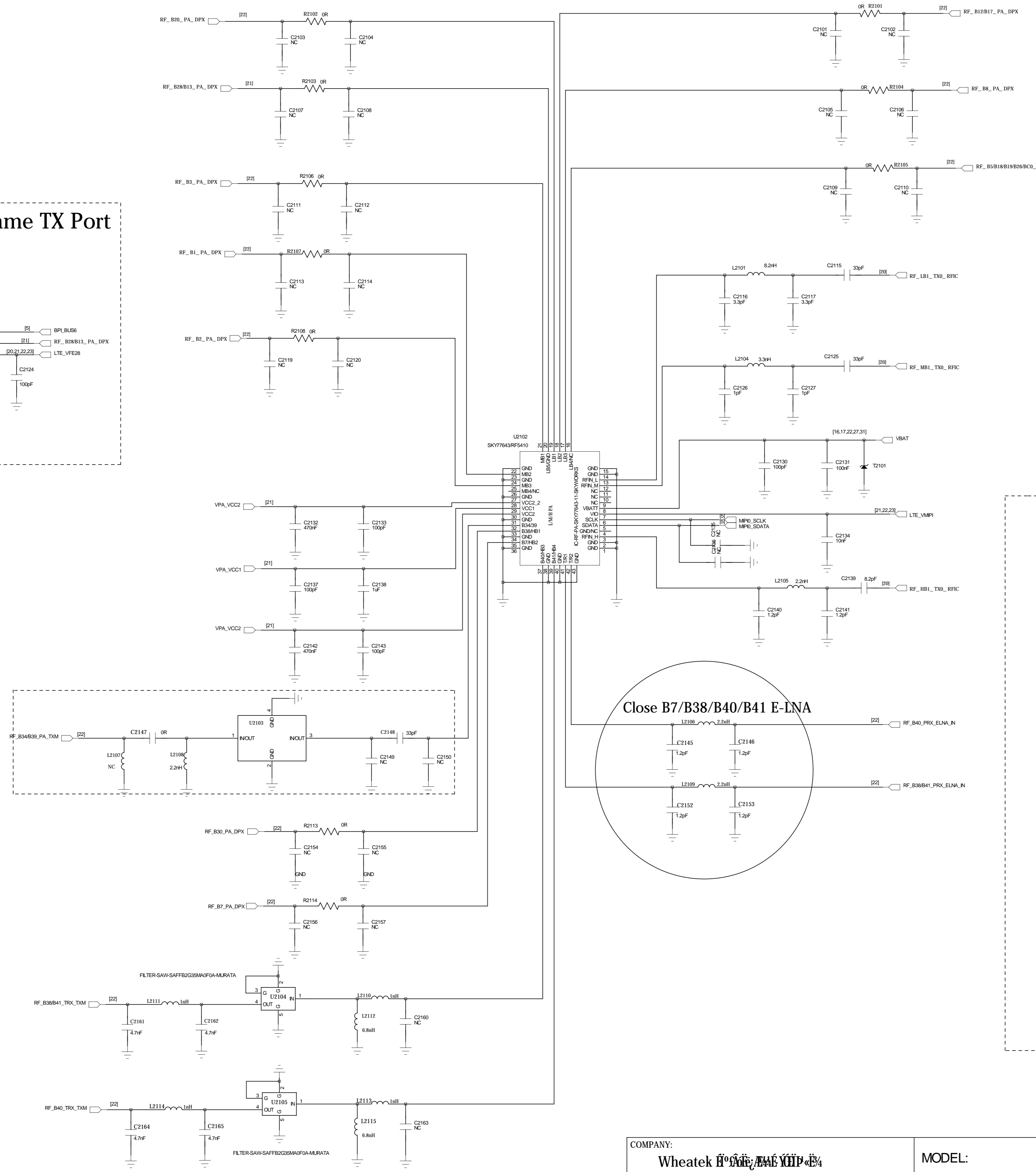
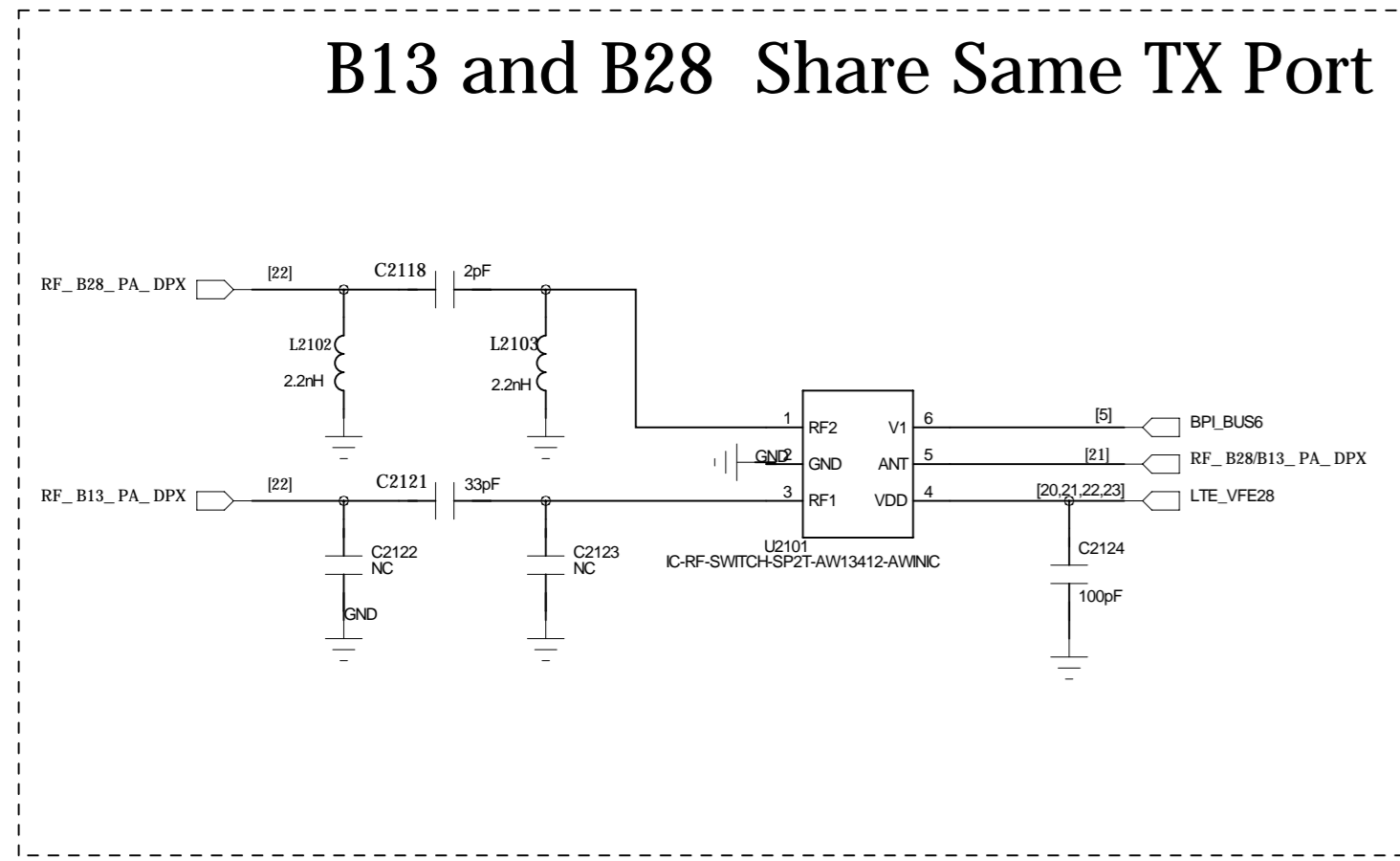

|                                      |       |       |            |                                   |  |                                  |                        |
|--------------------------------------|-------|-------|------------|-----------------------------------|--|----------------------------------|------------------------|
| COMPANY: <b>Wheatek Inc. / TE177</b> |       |       |            | MODEL: <b>TE177</b>               |  | Modified Date: <b>2022/10/21</b> |                        |
| DRAWN                                | WK/SP | DATED | 2022/09/22 | TITLE: <b>21_RF_MT6186M_RF_TX</b> |  | VERSION: <b>V1.1</b>             | SHEET: <b>21 OF 36</b> |
| CHECKED                              |       | DATED |            |                                   |  |                                  |                        |

### B1+B3 B4/B66 CA QPX

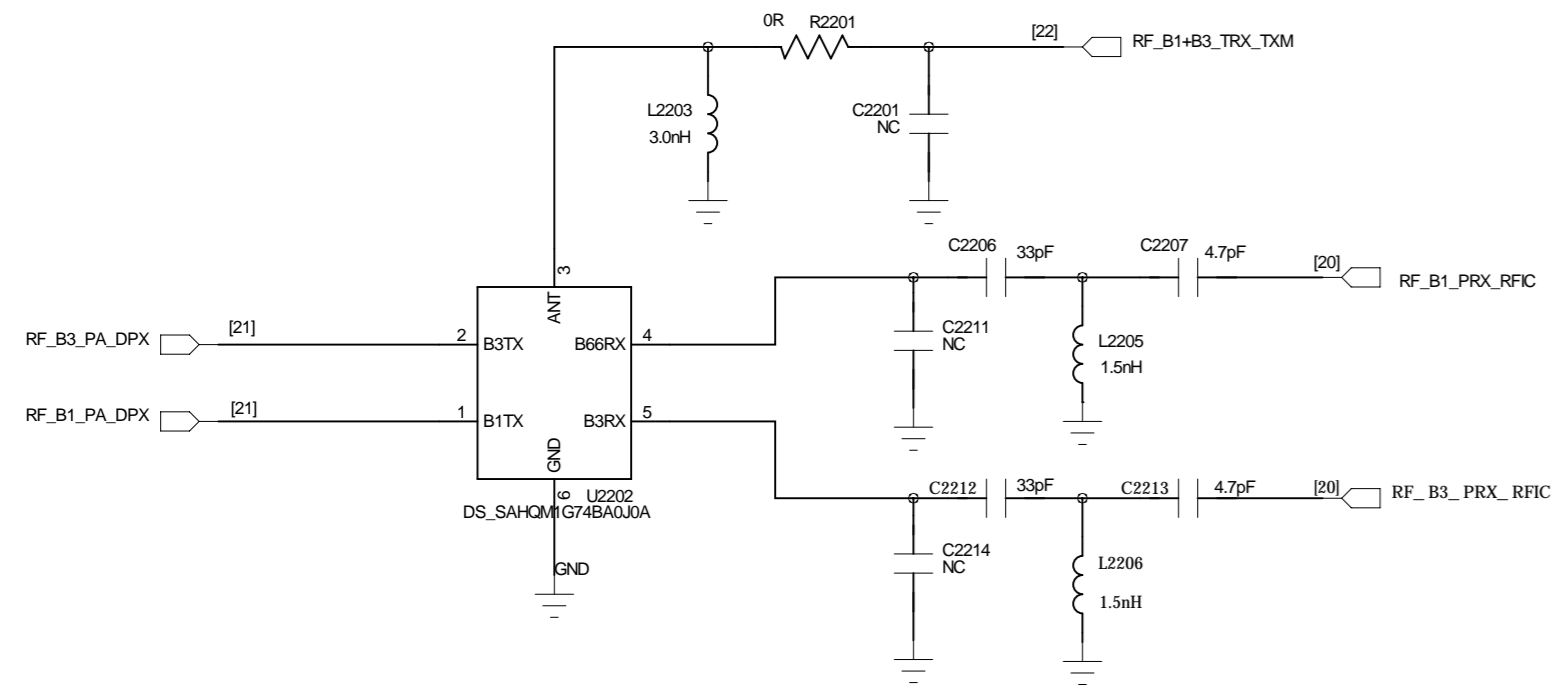

### B2/B25 TRX

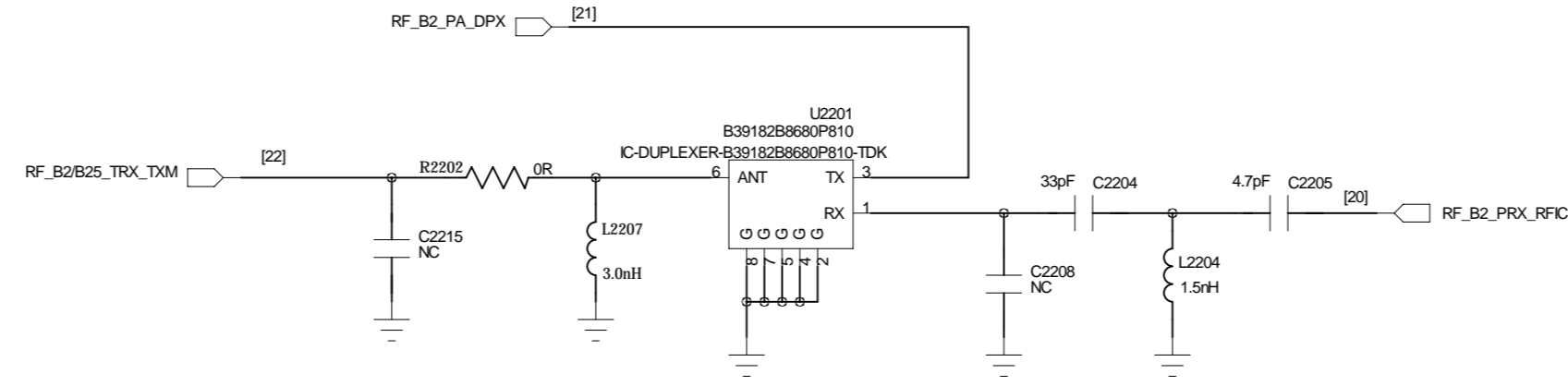

### B5/B18/B19/B26/BC0 TRX

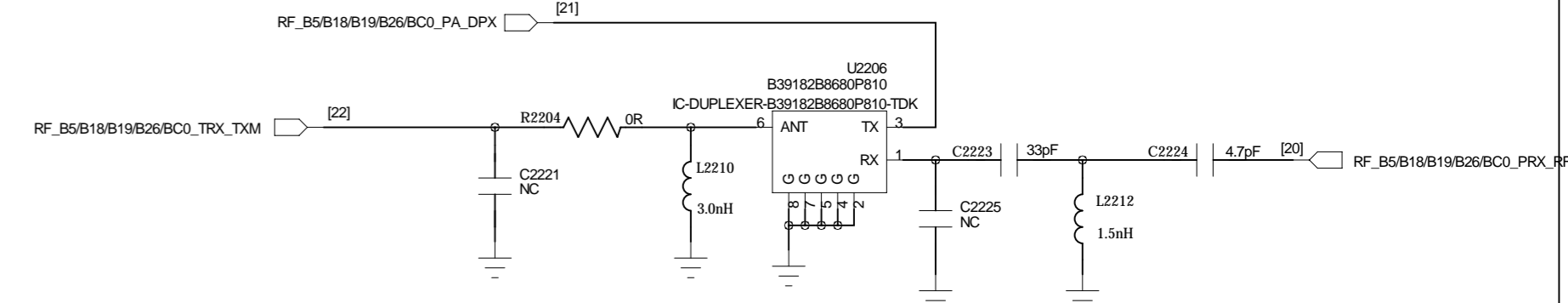

### B7 TRX

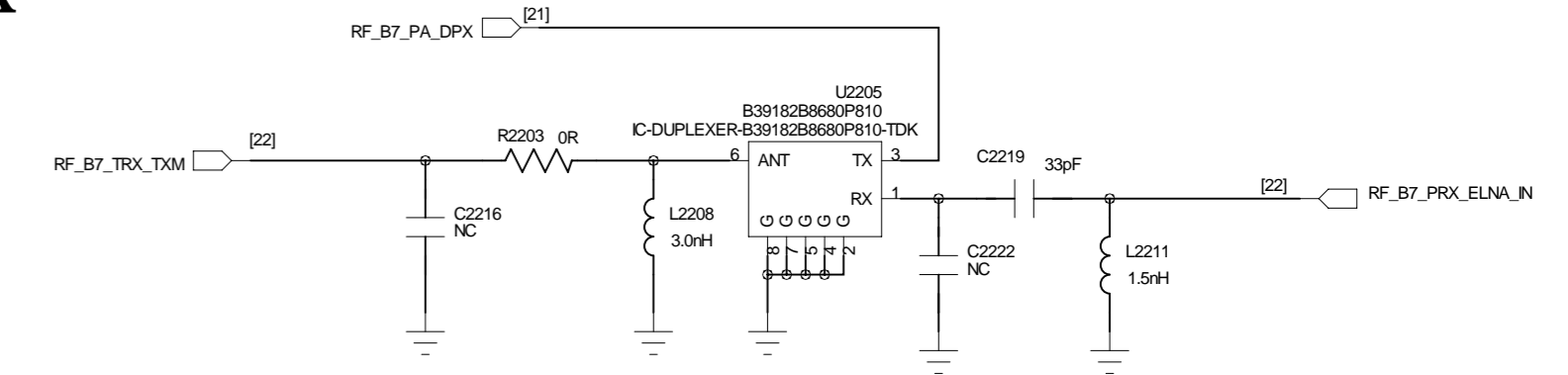

### B8 TRX

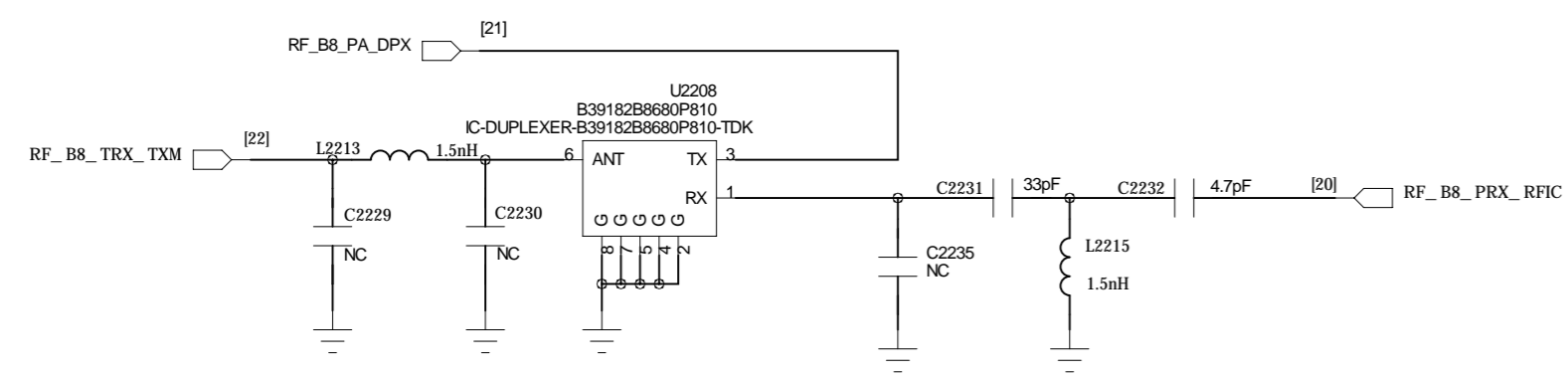

### B12/B17 TRX

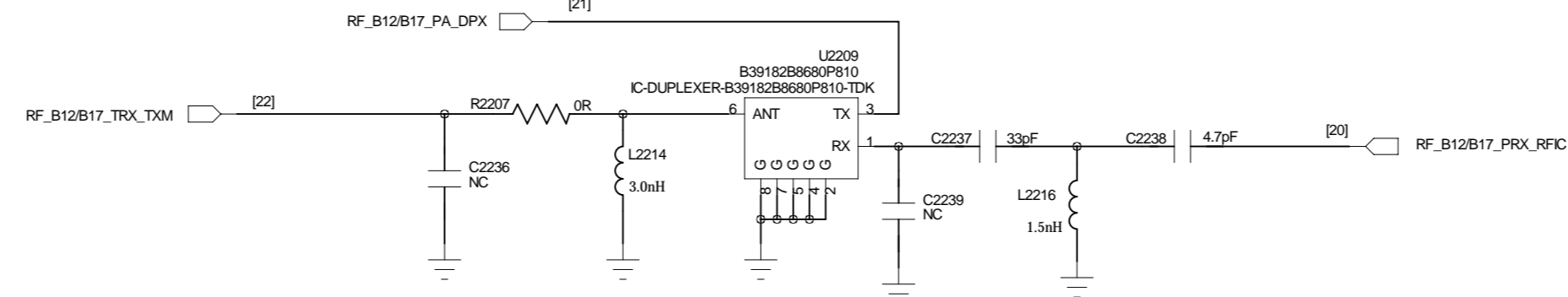

### B20 TRX

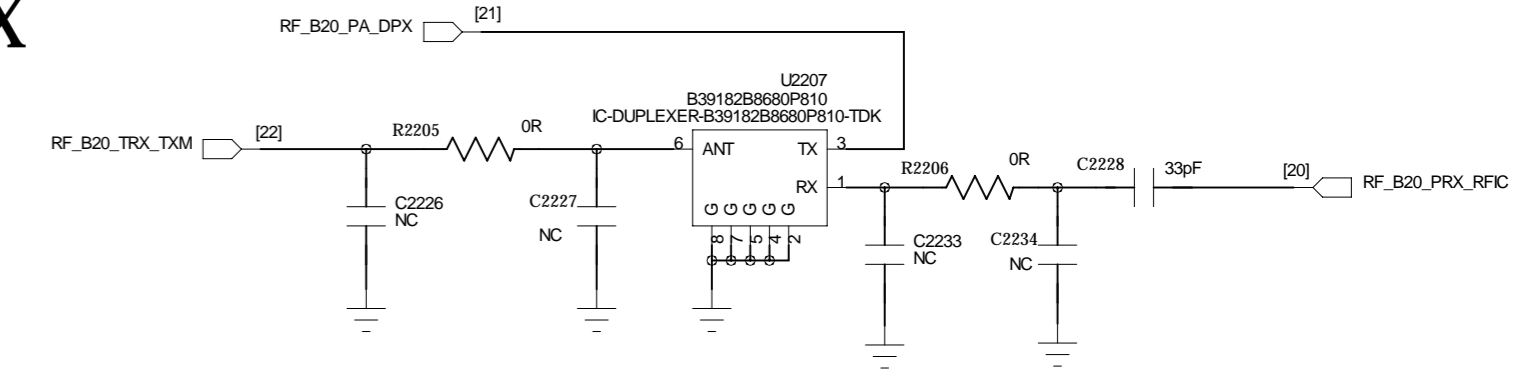

### B28(A+B) TRX

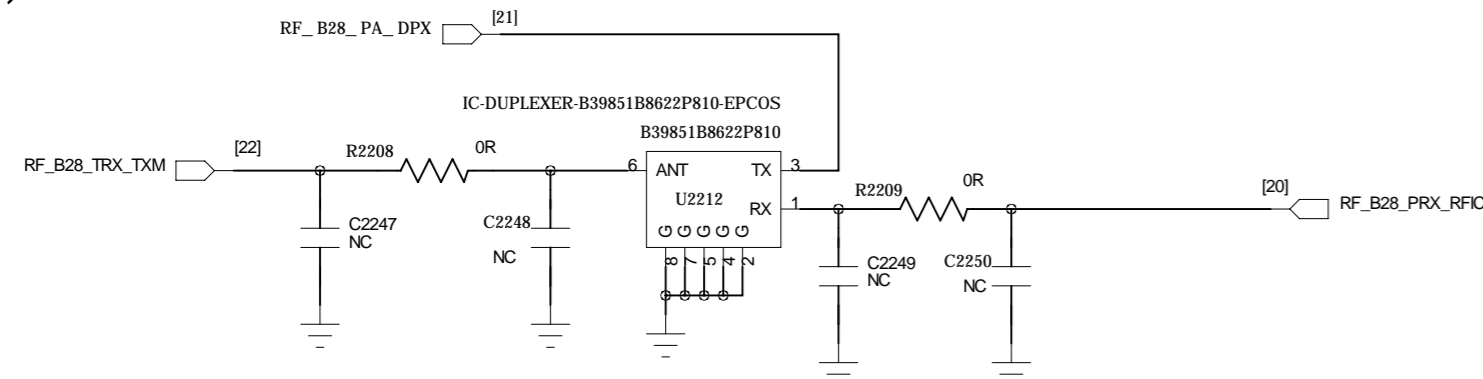

### B34/B39 PRX

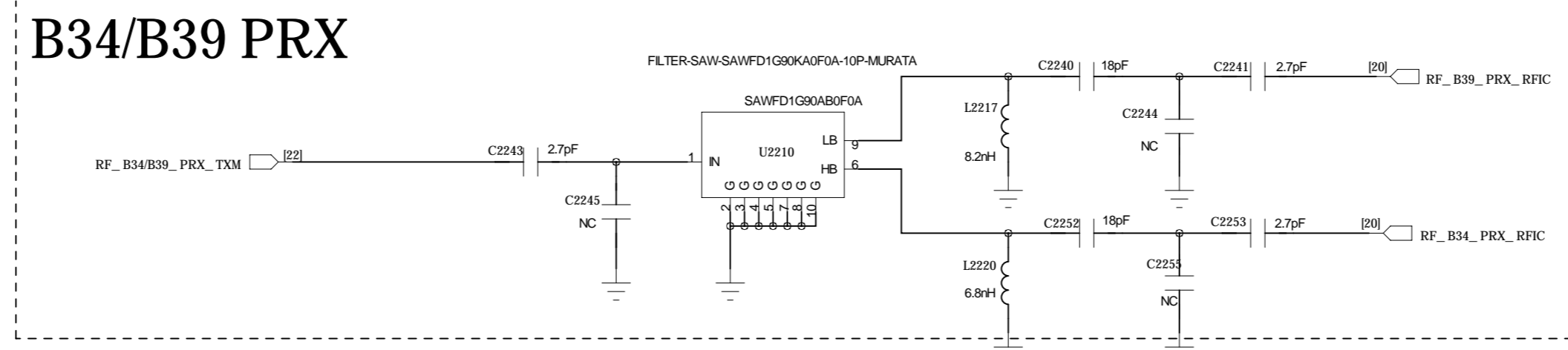

### B13 TRX

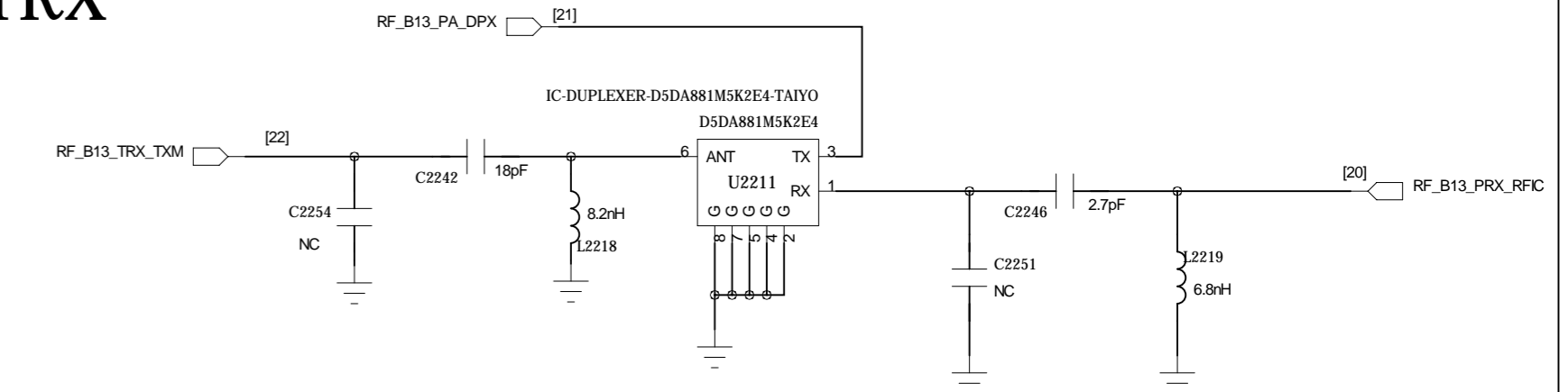

### B30 TRX

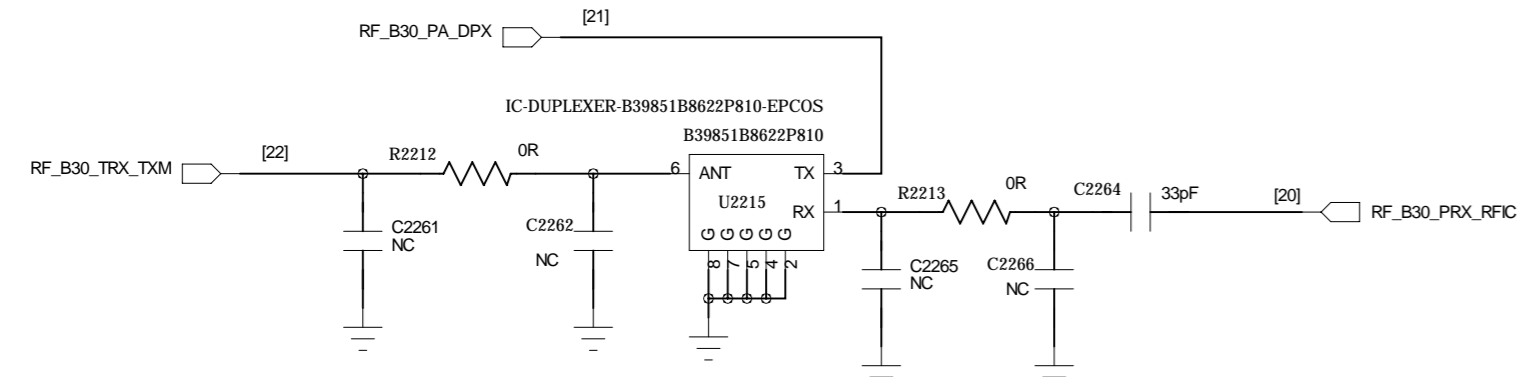

### B7/B40/B38/B41 PRX eLNA

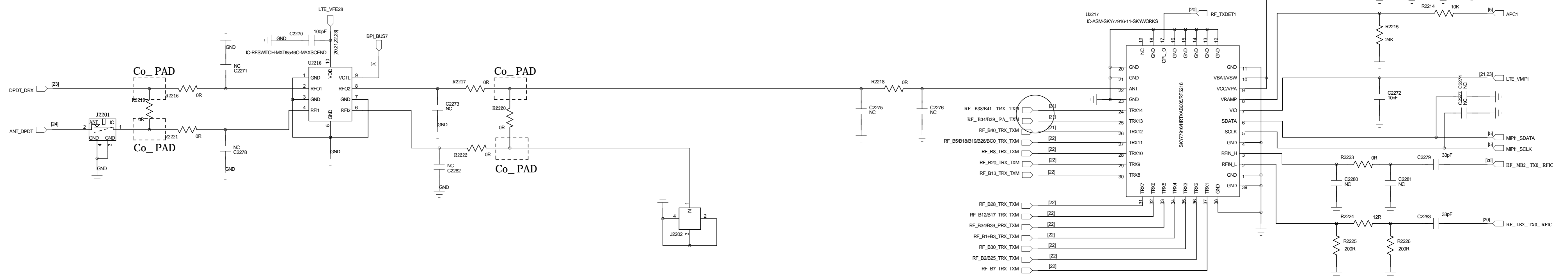
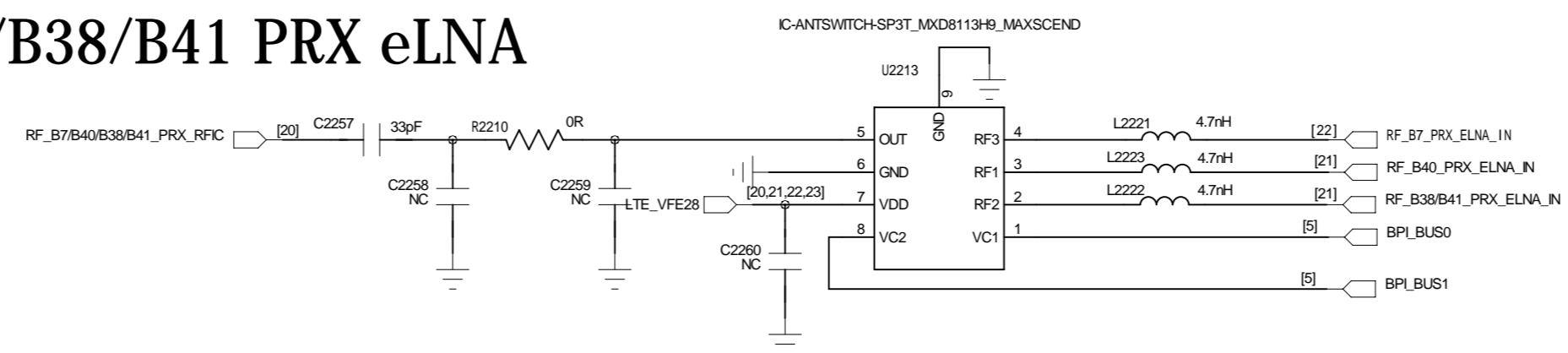

|                         |       |       |            |                                    |  |                                  |                        |
|-------------------------|-------|-------|------------|------------------------------------|--|----------------------------------|------------------------|
| COMPANY: <b>Wheatek</b> |       |       |            | MODEL: <b>TE177</b>                |  | Modified Date: <b>2022/10/21</b> |                        |
| DRAWN                   | WK/SP | DATED | 2022/09/22 | TITLE: <b>22_RF_MT6186M_RF_PRX</b> |  | VERSION: <b>V1.1</b>             | SHEET: <b>22 OF 36</b> |
| CHECKED                 |       | DATED |            |                                    |  |                                  |                        |
| 4                       |       |       |            | 3                                  |  | 2                                |                        |
| 4                       |       |       |            | 3                                  |  | 1                                |                        |

# B1/B4/B66/B3 DRX (B1+B3 CA)

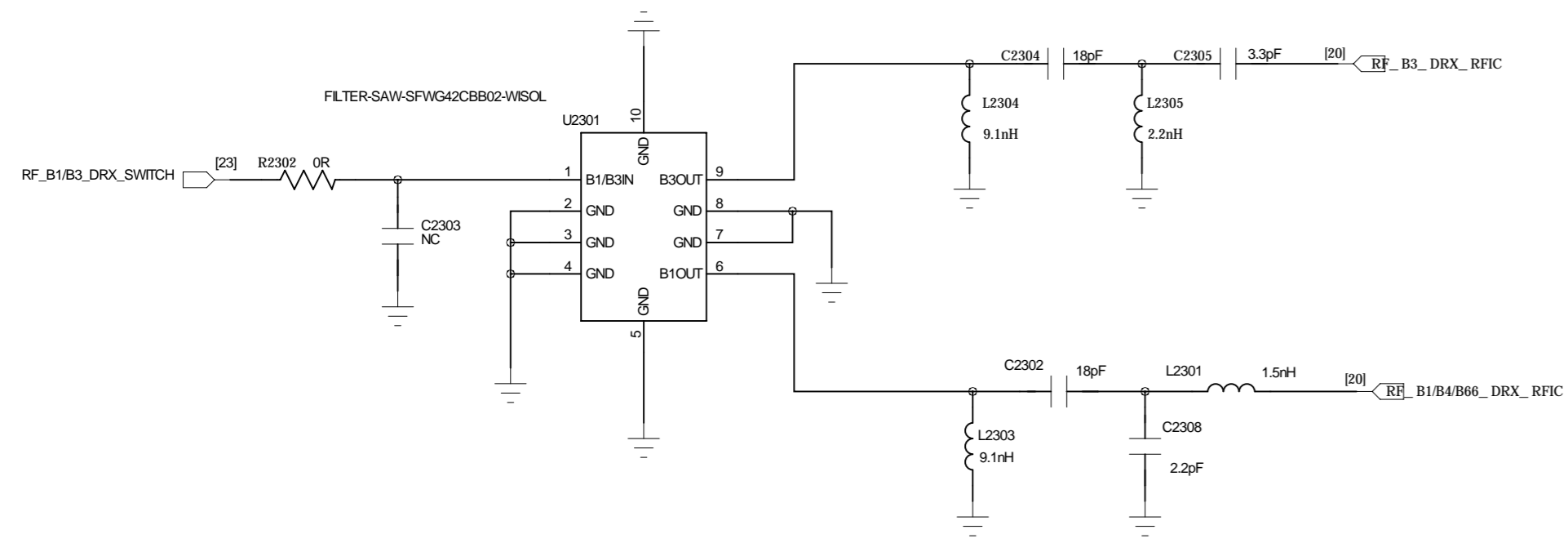

# B2/B25 DRX

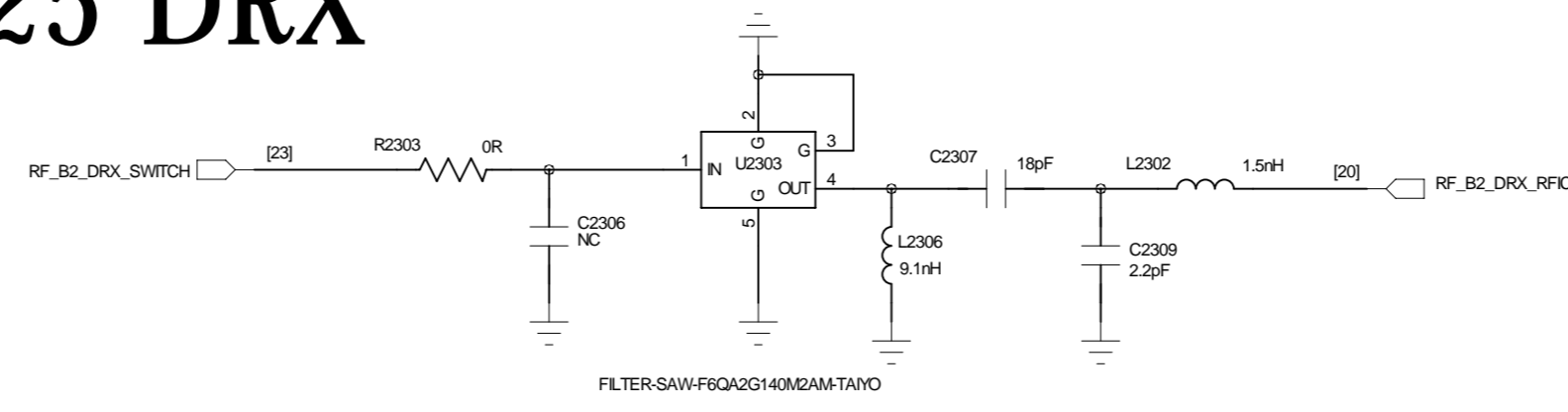

# B5/B18/B19/B26/BC0 DRX

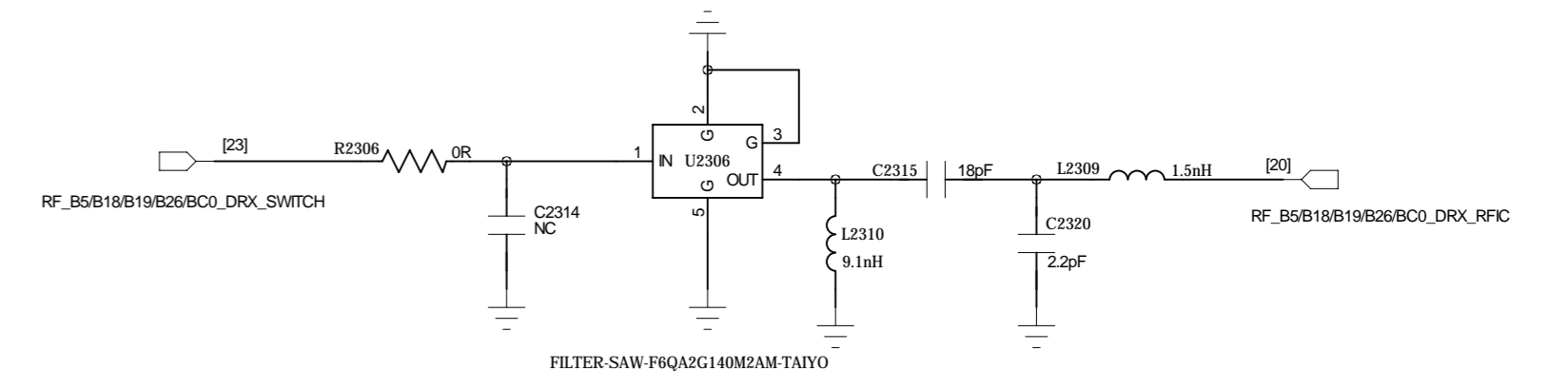

# B7 DRX

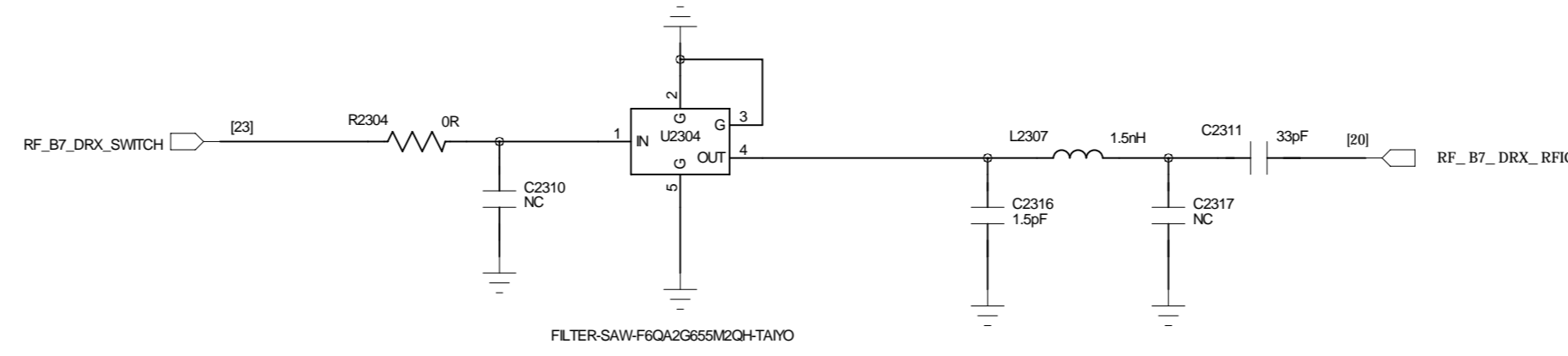

# B8 DRX

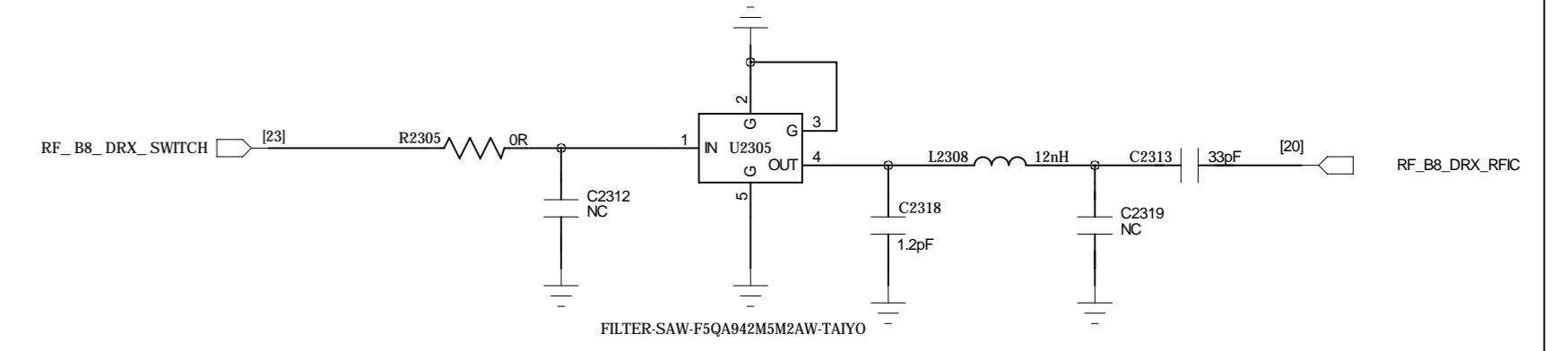

# B28 DRX

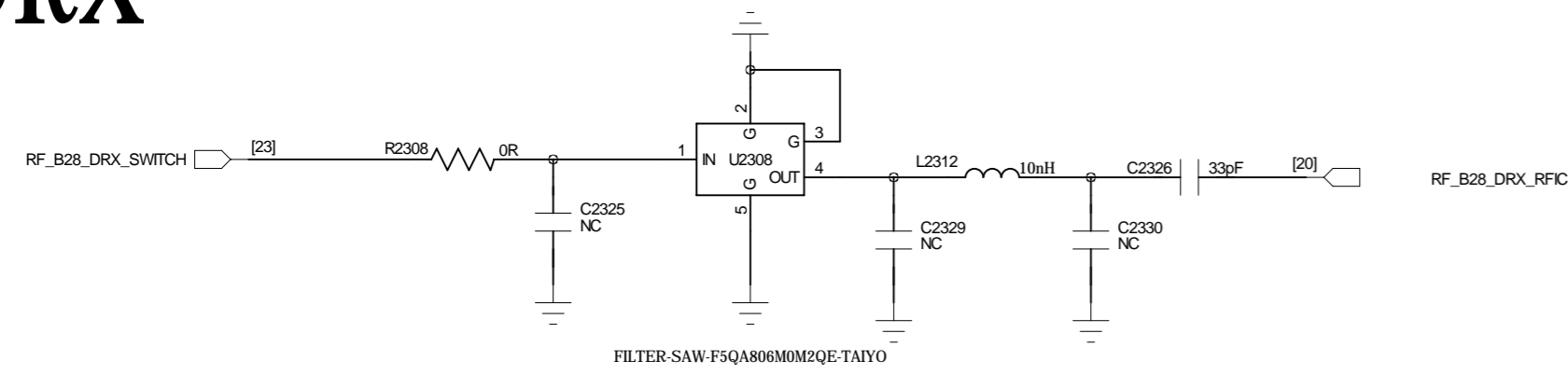

# B20 DRX

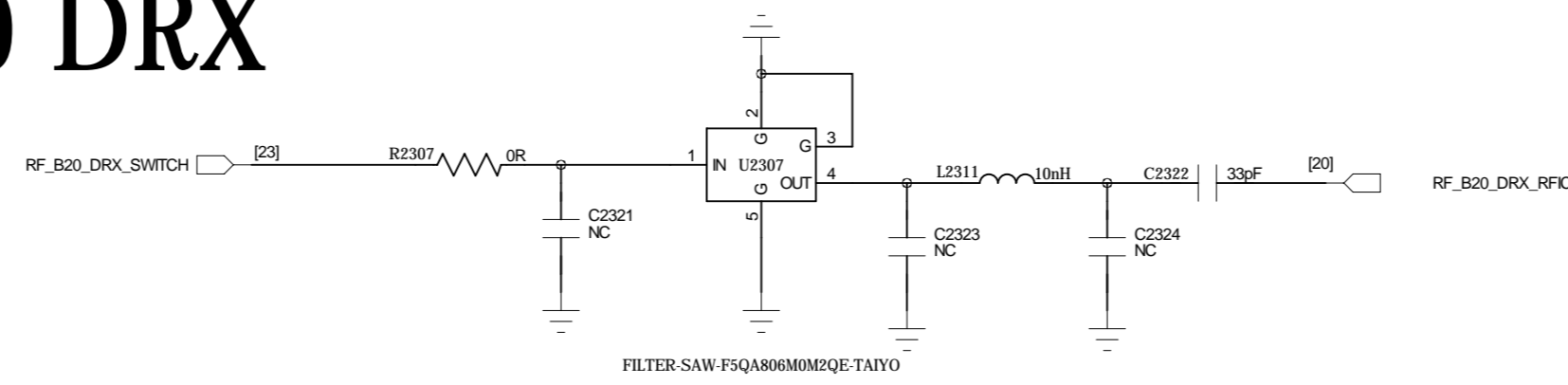

# B12/B13/B17 DRX

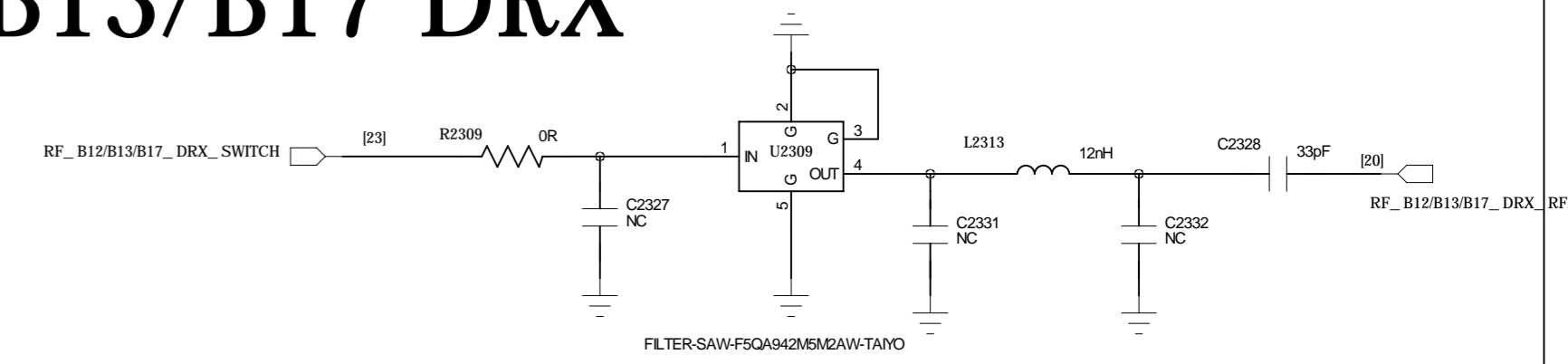

# B40 DRX

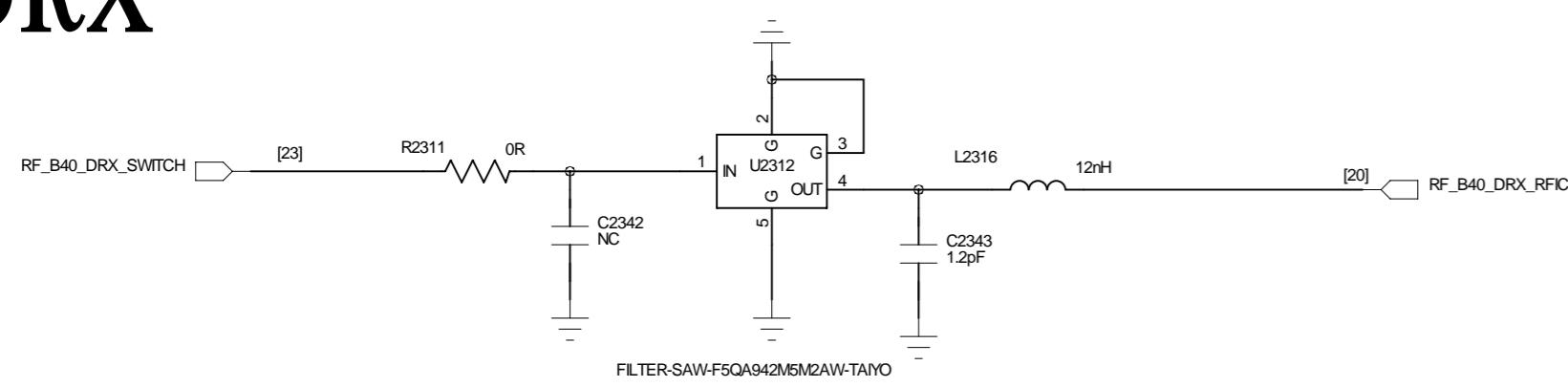

# B38/B41 DRX

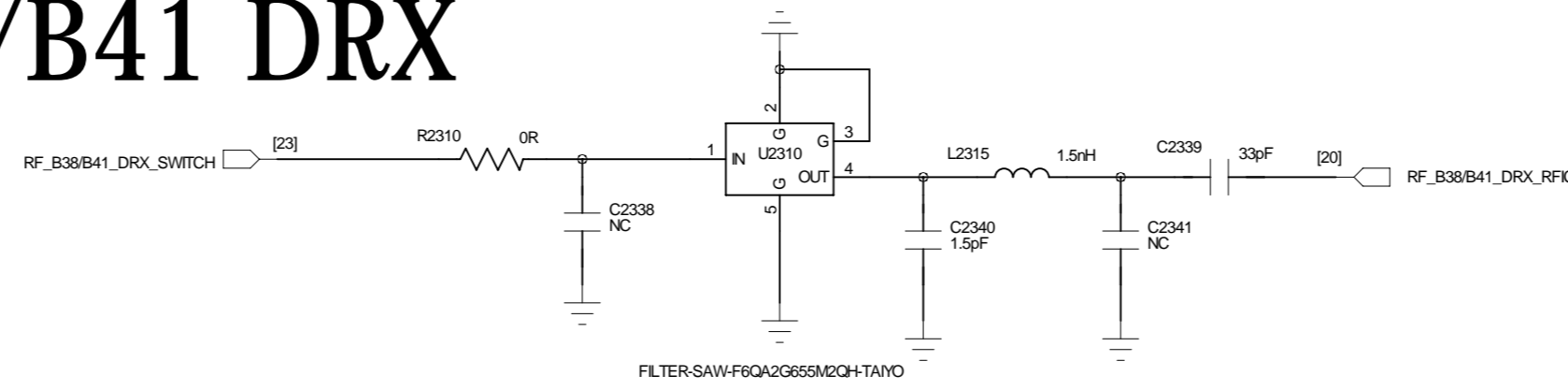

# B34/B39 DRX

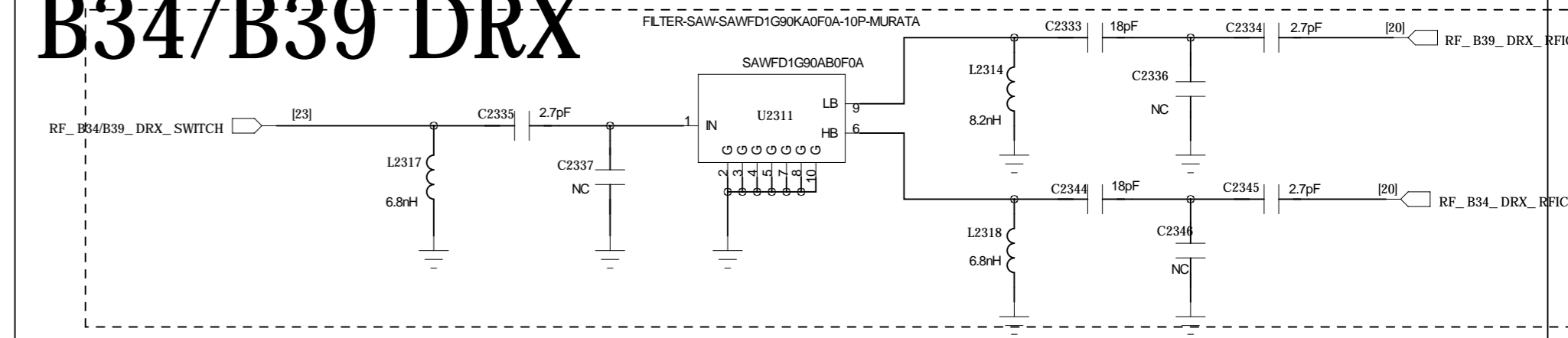

# B30 DRX

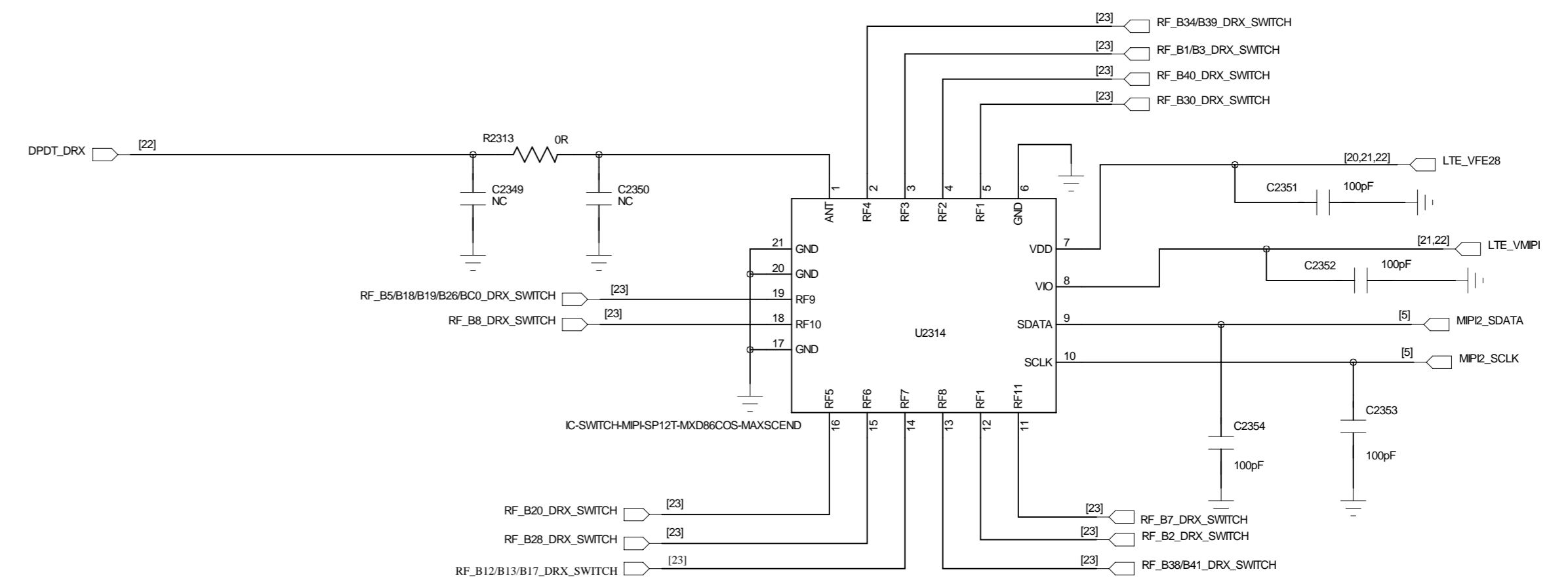
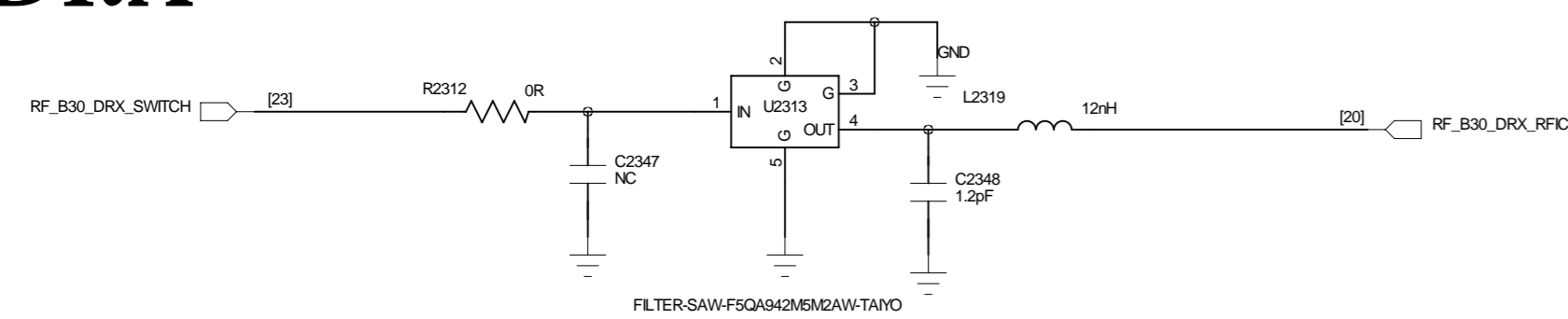

|                                 |       |       |            |                             |                           |
|---------------------------------|-------|-------|------------|-----------------------------|---------------------------|
| COMPANY: Wheatek 10016, MA10016 |       |       |            | MODEL: TE177                | Modified Date: 2022/10/21 |
| DRAWN                           | WK/SP | DATED | 2022/09/22 | TITLE: 23_RF_MT6186M_RF_DRX | VERSION: V1.1             |
| CHECKED                         |       | DATED |            |                             | SHEET: 23 OF 36           |

# ANT1 (DRX\_LB+MHB)

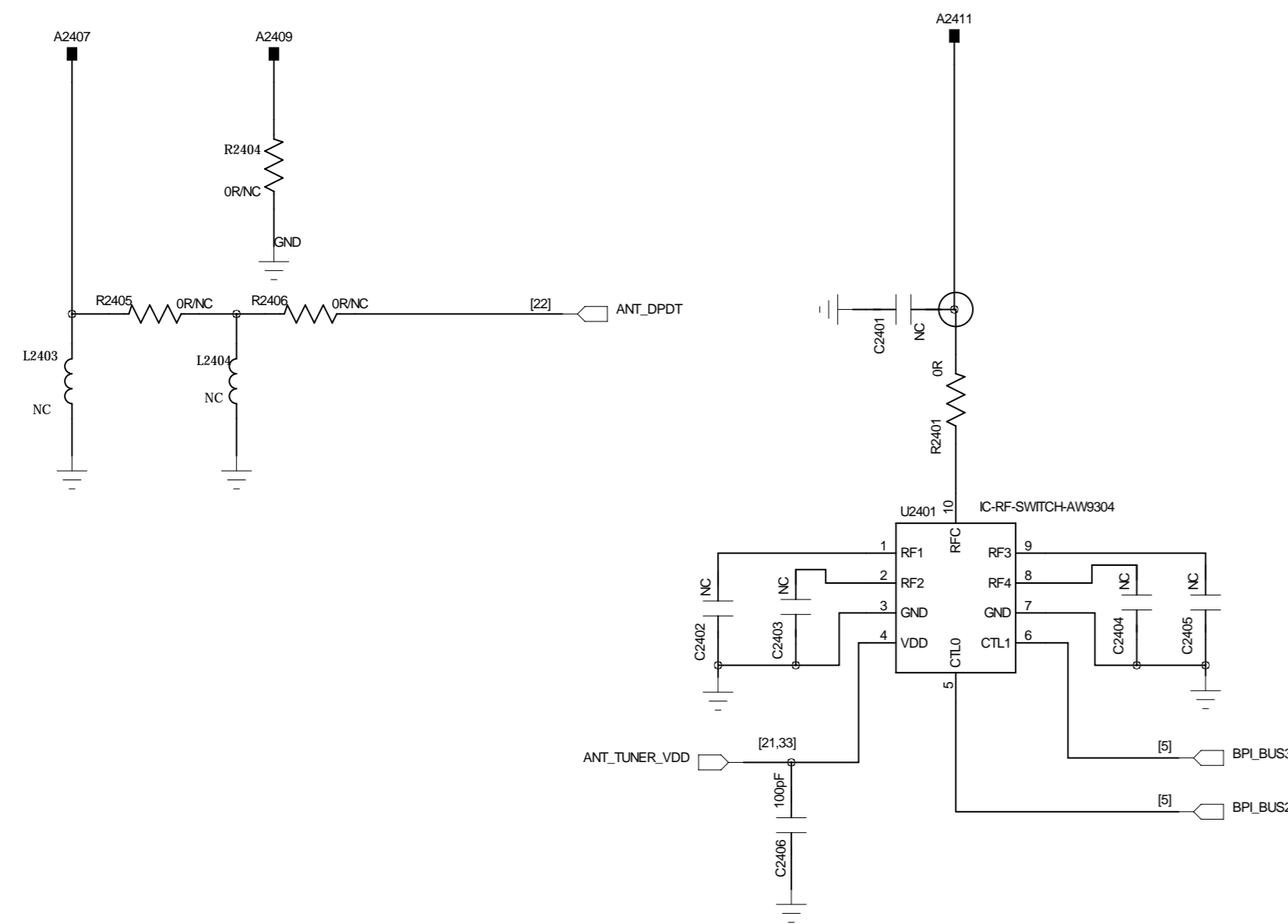

# ANT2 (WBG\_L1/2.4G/5G)

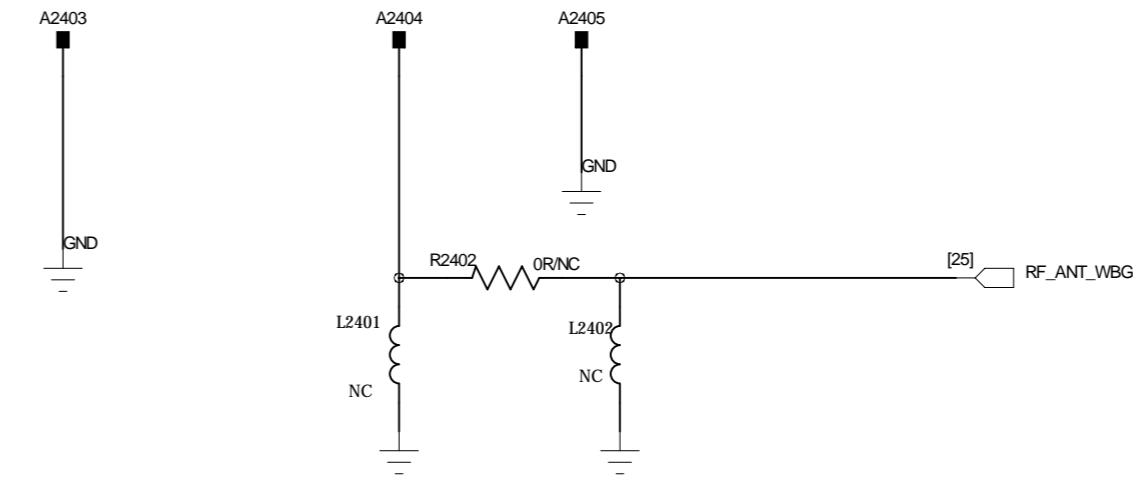

## 接地弹片

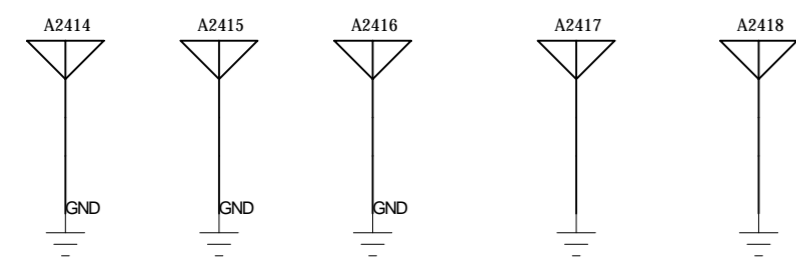

## Cable Cleat

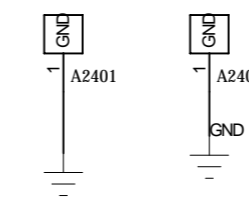

|                                    |       |       |            |                         |                                  |
|------------------------------------|-------|-------|------------|-------------------------|----------------------------------|
| COMPANY: <b>Wheatek 禾泰科技股份有限公司</b> |       |       |            | MODEL: <b>TE177</b>     | Modified Date: <b>2022/10/21</b> |
| DRAWN                              | WK/SP | DATED | 2022/09/22 | TITLE: <b>24_RF_ANT</b> | VERSION: <b>V1.1</b>             |
| CHECKED                            |       | DATED |            |                         | SHEET: <b>24 OF 36</b>           |



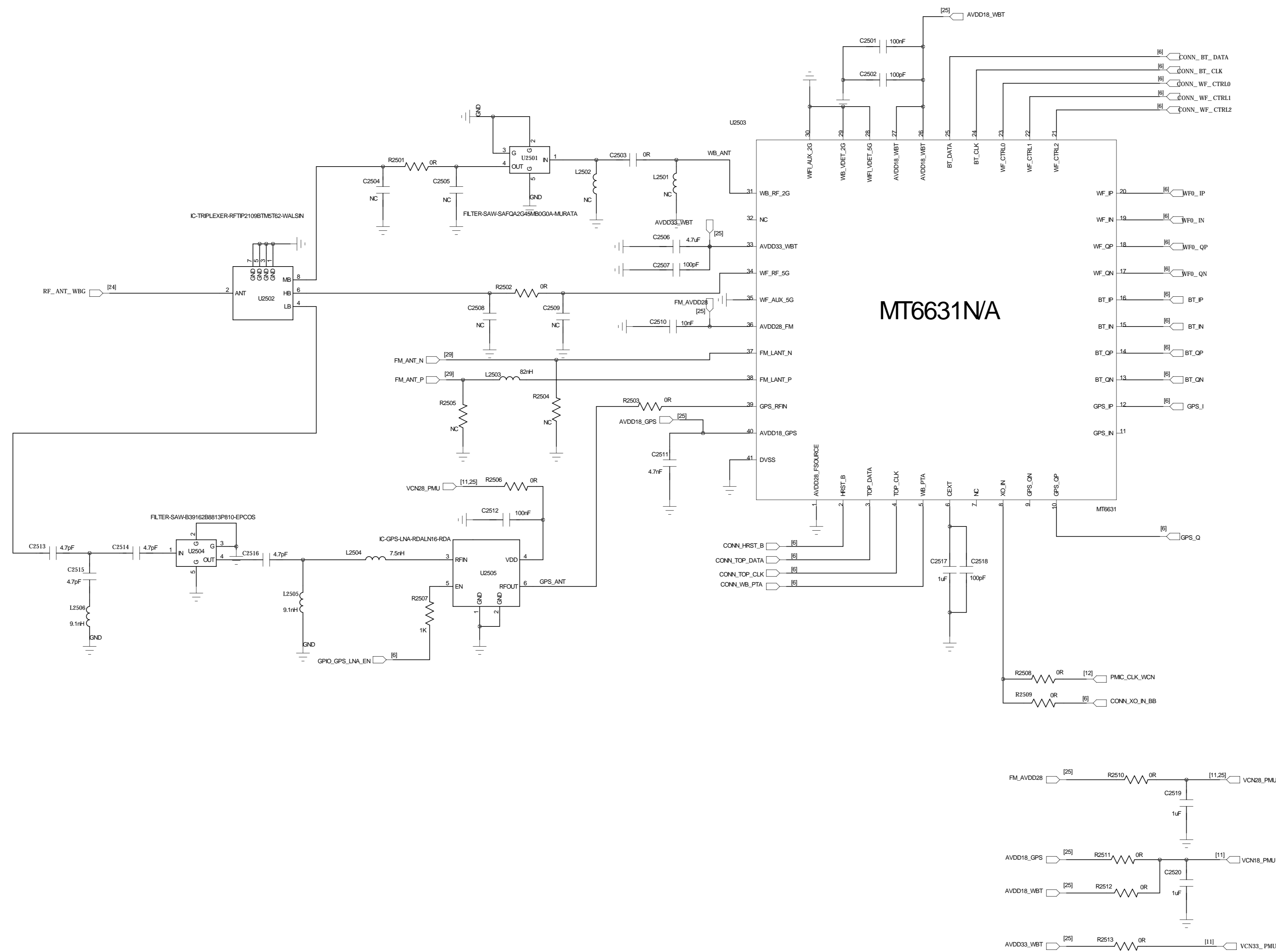

|                         |       |       |            |                               |  |                           |                 |
|-------------------------|-------|-------|------------|-------------------------------|--|---------------------------|-----------------|
| COMPANY: <b>Wheatek</b> |       |       |            | MODEL: <b>TE177</b>           |  | Modified Date: 2022/10/21 |                 |
| DRAWN                   | WK/SP | DATED | 2022/09/22 | TITLE: 25_CONNECTIVITY_MT6631 |  | VERSION: V1.1             | SHEET: 25 OF 36 |
| CHECKED                 |       | DATED |            |                               |  |                           |                 |

# SIM+SD\_Card

# SIM\_SD\_Card

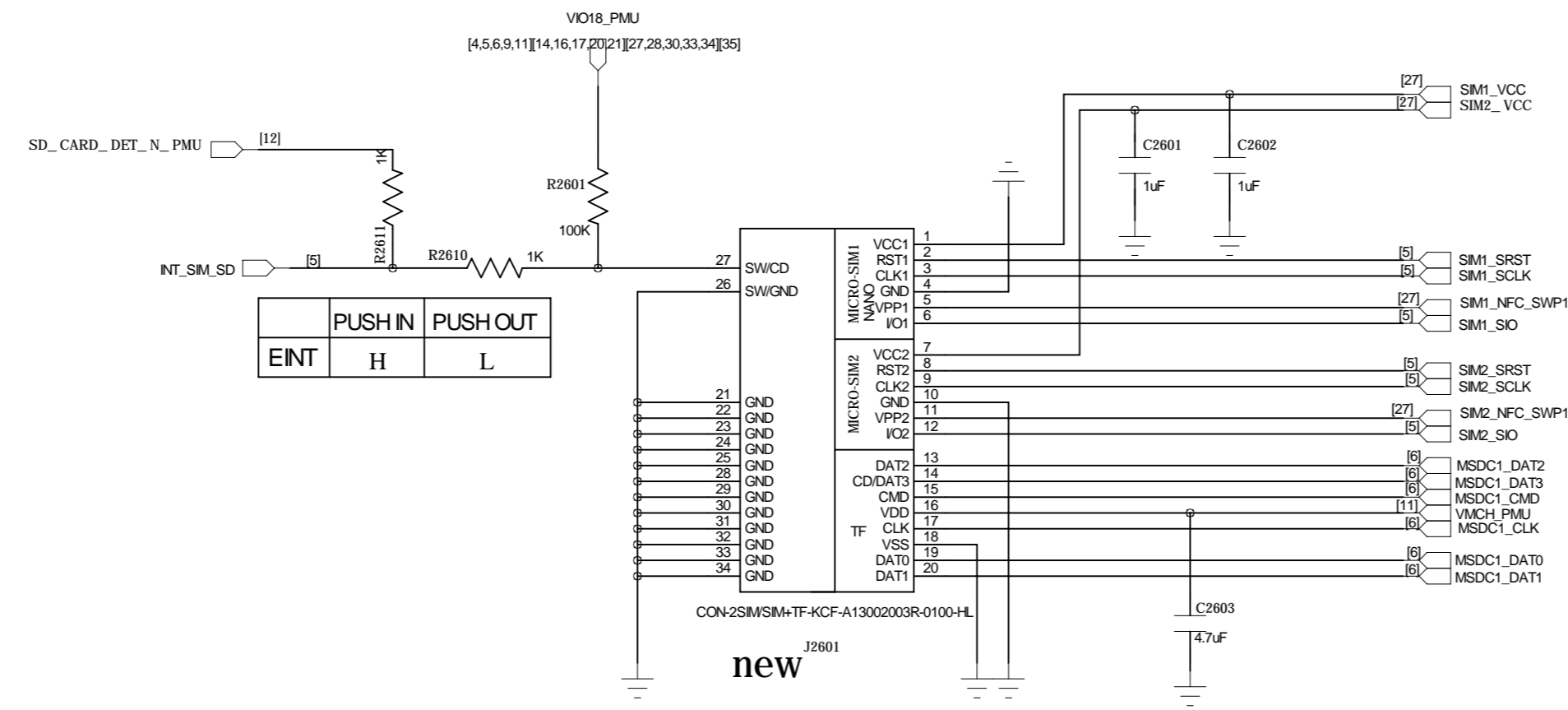

## Power Key / Key Pad

DO NOT put pull-up resistor on PWRKEY

## Power Key / Key1+2

Note: 75-2

KW0KLO: Volume Up  
KW0KLI: Volume Down

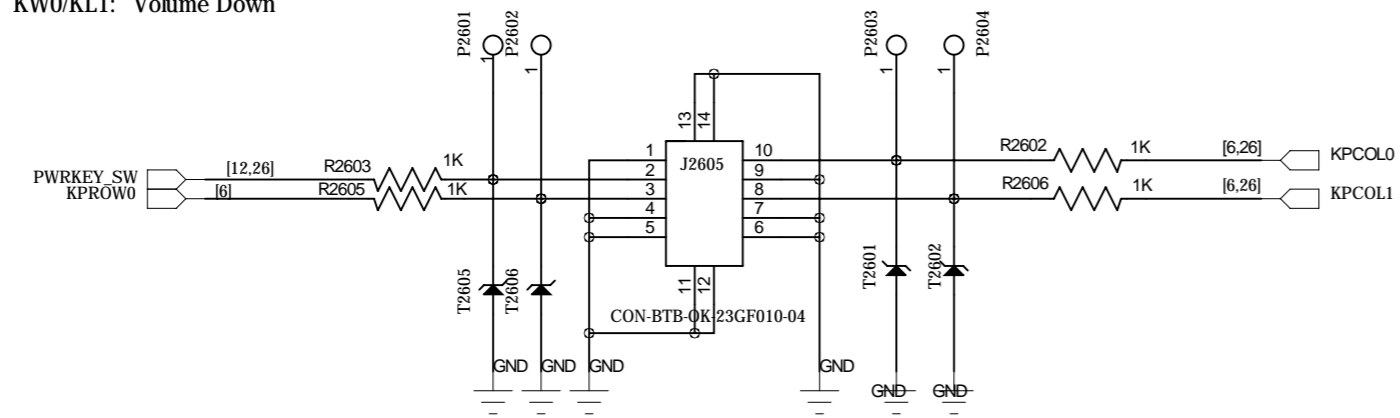

## Power Key / Key Pad

DO NOT put pull-up resistor on PWRKEY

## Power Key / Key3+4

Note: 75-2

KW1KLO: Volume Up  
KW1KLI: Volume Down

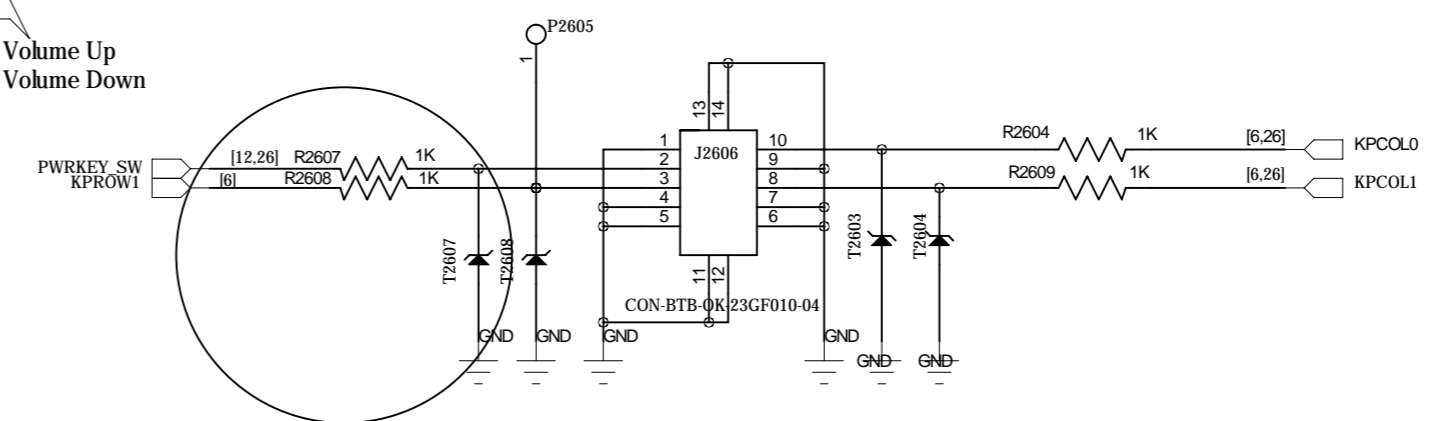

|                              |       |       |            |                           |  |                           |                 |
|------------------------------|-------|-------|------------|---------------------------|--|---------------------------|-----------------|
| COMPANY: Wheatek Electronics |       |       |            | MODEL: TE177              |  | Modified Date: 2022/10/21 |                 |
| DRAWN                        | WK/SP | DATED | 2022/09/22 | TITLE: 26_PERI_SIM_SD_KEY |  | VERSION: V1.1             | SHEET: 26 OF 36 |
| CHECKED                      |       | DATED |            |                           |  |                           |                 |

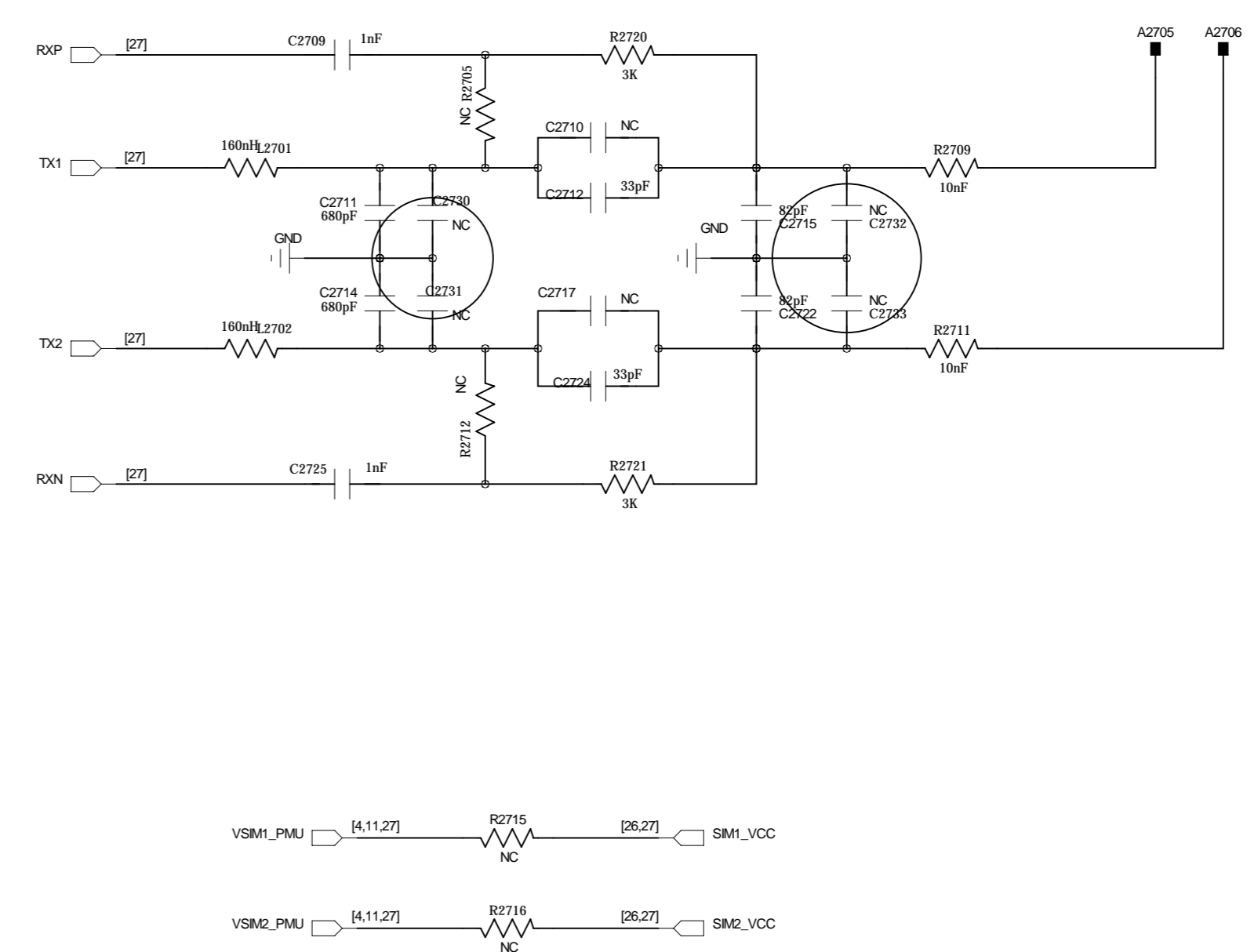
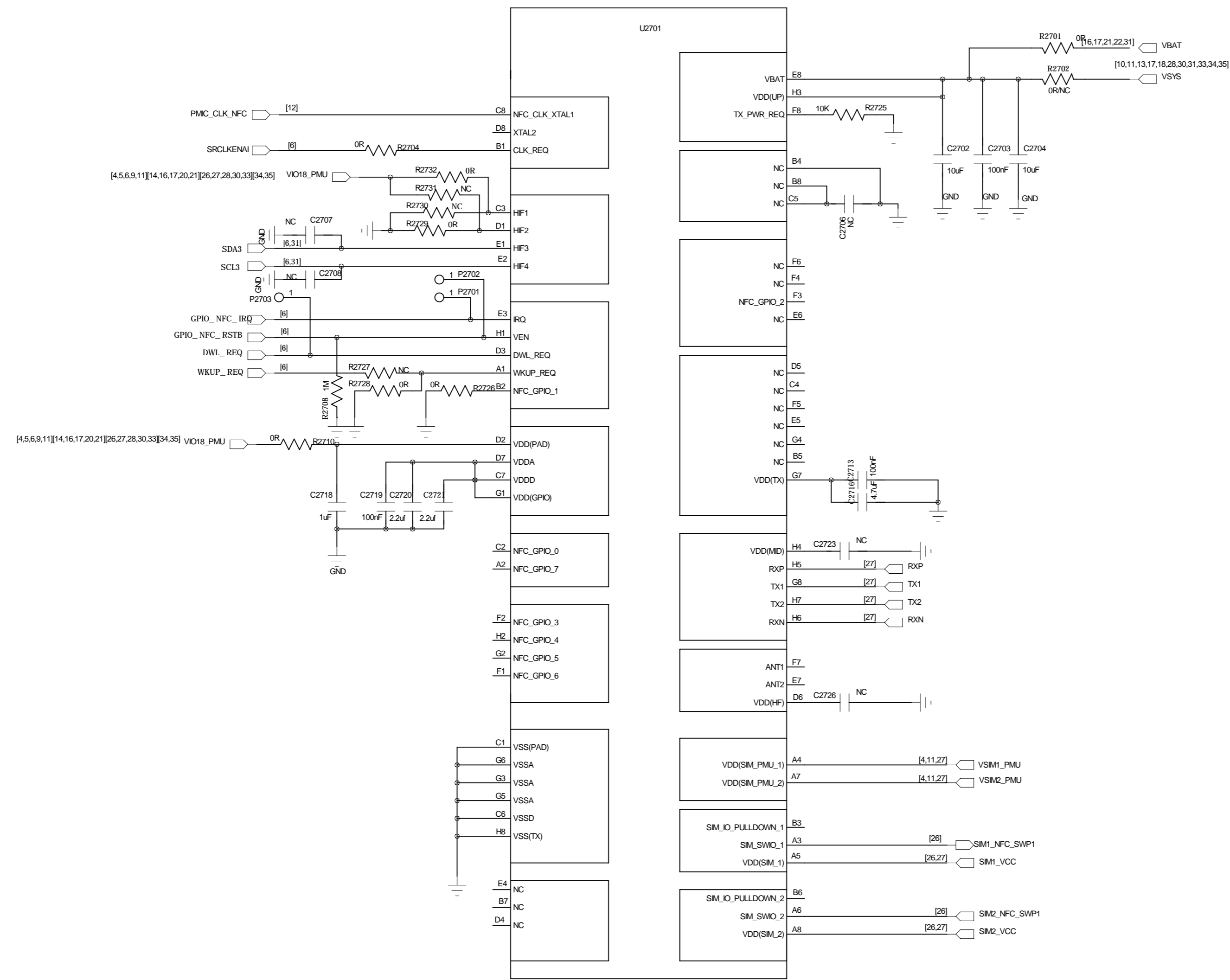

I2C

Table 11. I2C-bus interface addressing

| HF2 | HF1 | I2C-bus address (R/W = 0, write) | I2C-bus address (R/W = 1, read) |
|-----|-----|----------------------------------|---------------------------------|
| 0   | 0   | 0x50                             | 0x51                            |
| 0   | 1   | 0x52                             | 0x53                            |
| 1   | 0   | 0x54                             | 0x55                            |
| 1   | 1   | 0x56                             | 0x57                            |

|  |       |       |            |                                   |  |                                  |                        |
|--|-------|-------|------------|-----------------------------------|--|----------------------------------|------------------------|
| COMPANY: <b>Wheatek Technology Co., Ltd.</b> |       |       |            | MODEL: <b>TE177</b>               |  | Modified Date: <b>2022/10/21</b> |                        |
| DRAWN  | WK/SP | DATED | 2022/09/22 | TITLE: <b>27_CONNECTIVITY_NFC</b> |  | VERSION: <b>V1.1</b>             | SHEET: <b>27 OF 36</b> |
| CHECKED                                      |       | DATED |            |                                   |  |                                  |                        |
| 4  |       | 3     |            | 2                                 |  | 1                                |                        |

# SMART PA

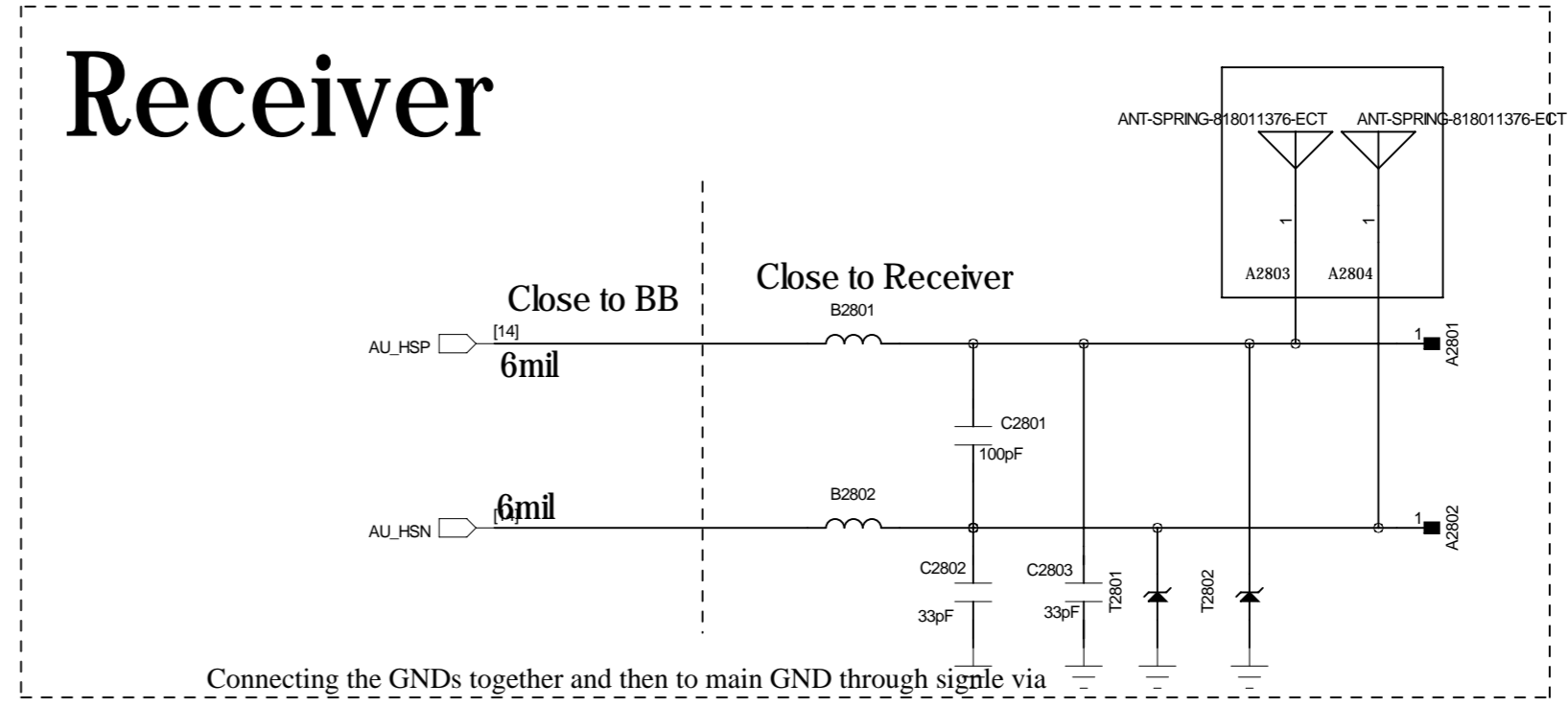
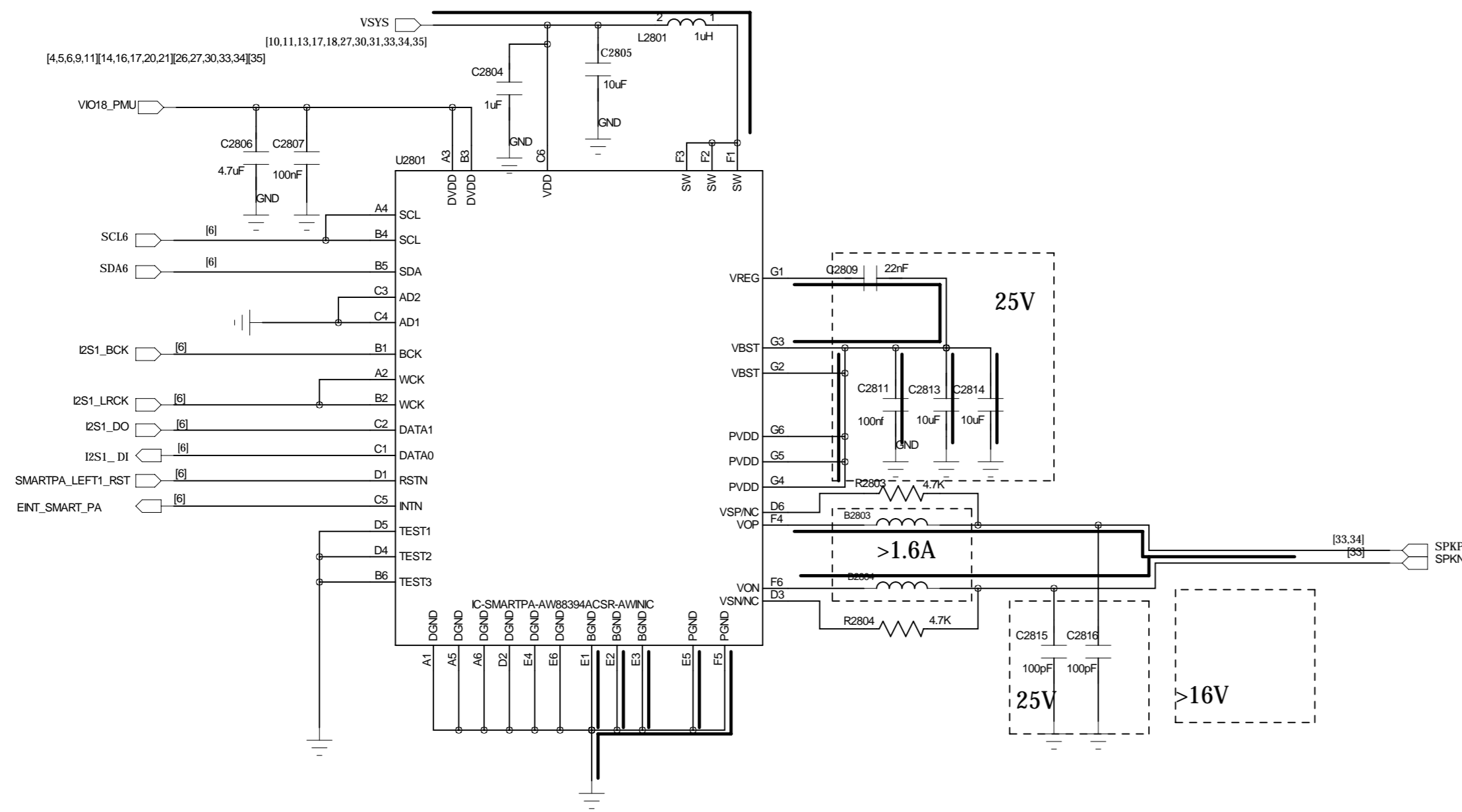

Connecting the GNDs together and then to main GND through signal via

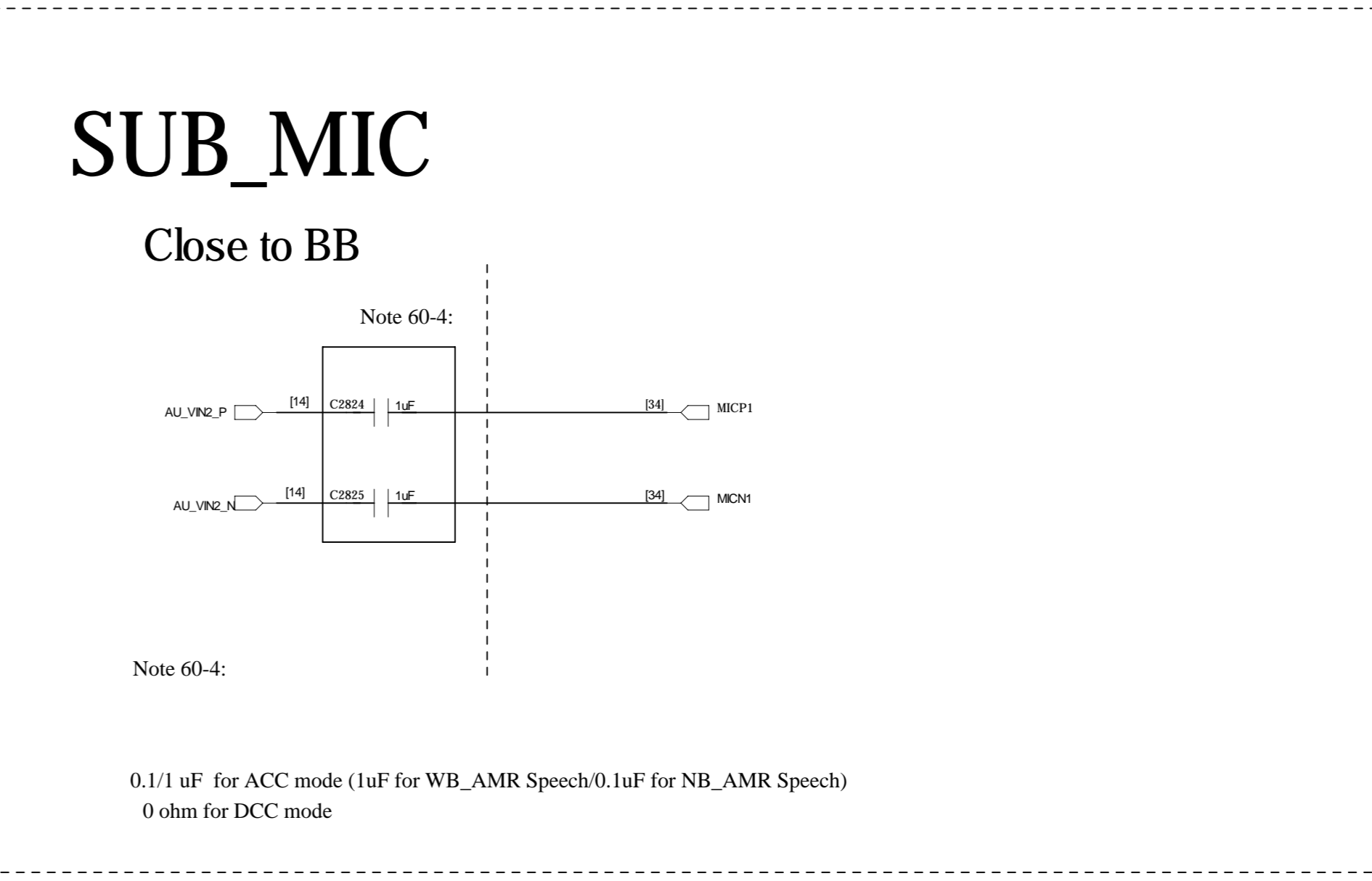
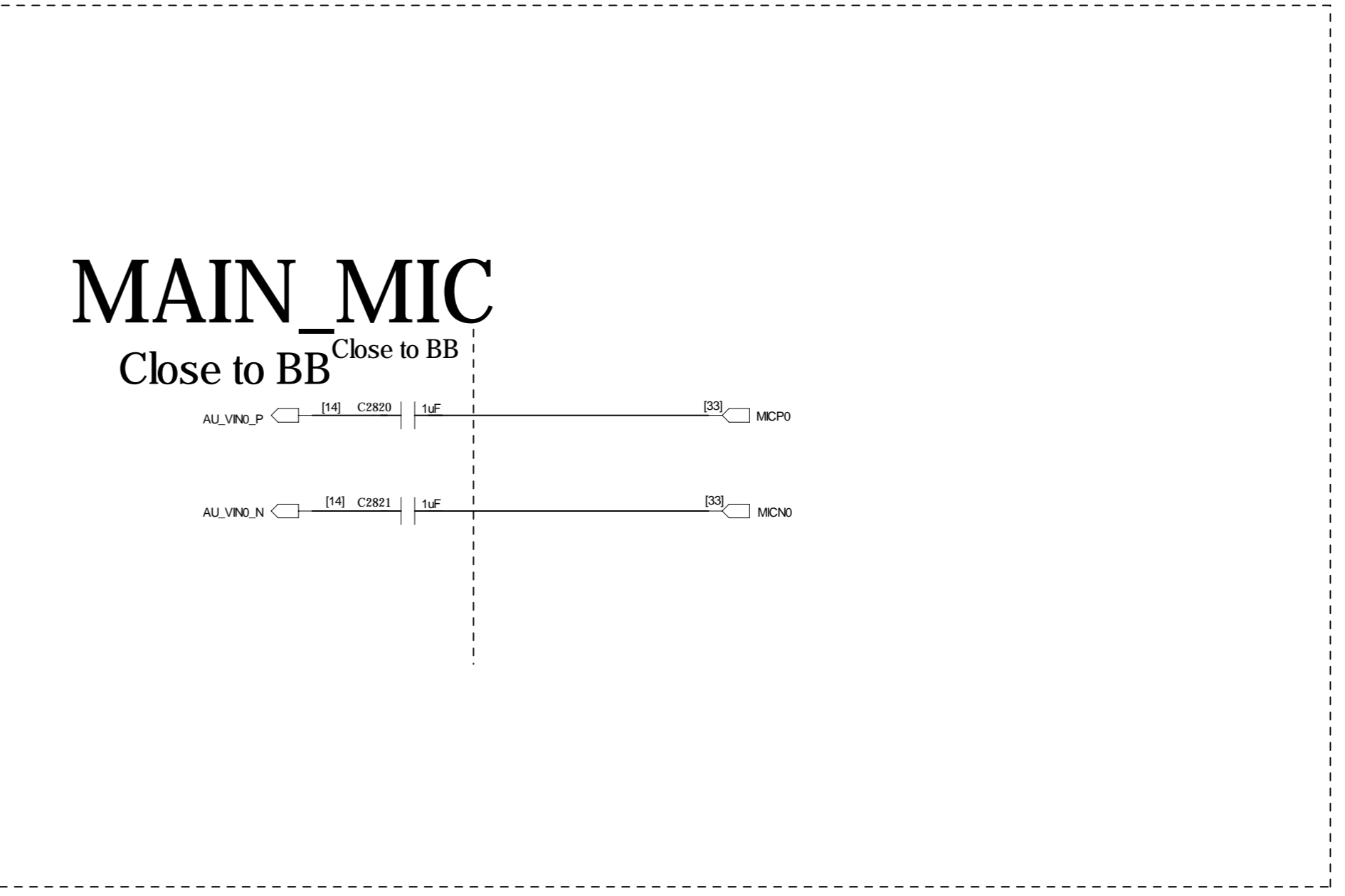

|  |       |       |            |                                   |  |                                  |                        |
|--|-------|-------|------------|-----------------------------------|--|----------------------------------|------------------------|
| COMPANY: <b>Wheatek Technology Co., Ltd.</b> |       |       |            | MODEL: <b>TE177</b>               |  | Modified Date: <b>2022/10/21</b> |                        |
| DRAWN  | WK/SP | DATED | 2022/09/22 | TITLE: <b>28_PERI_AUDIOPA_MIC</b> |  | VERSION: <b>V1.1</b>             | SHEET: <b>28 OF 36</b> |
| CHECKED                                      |       | DATED |            |                                   |  |                                  |                        |

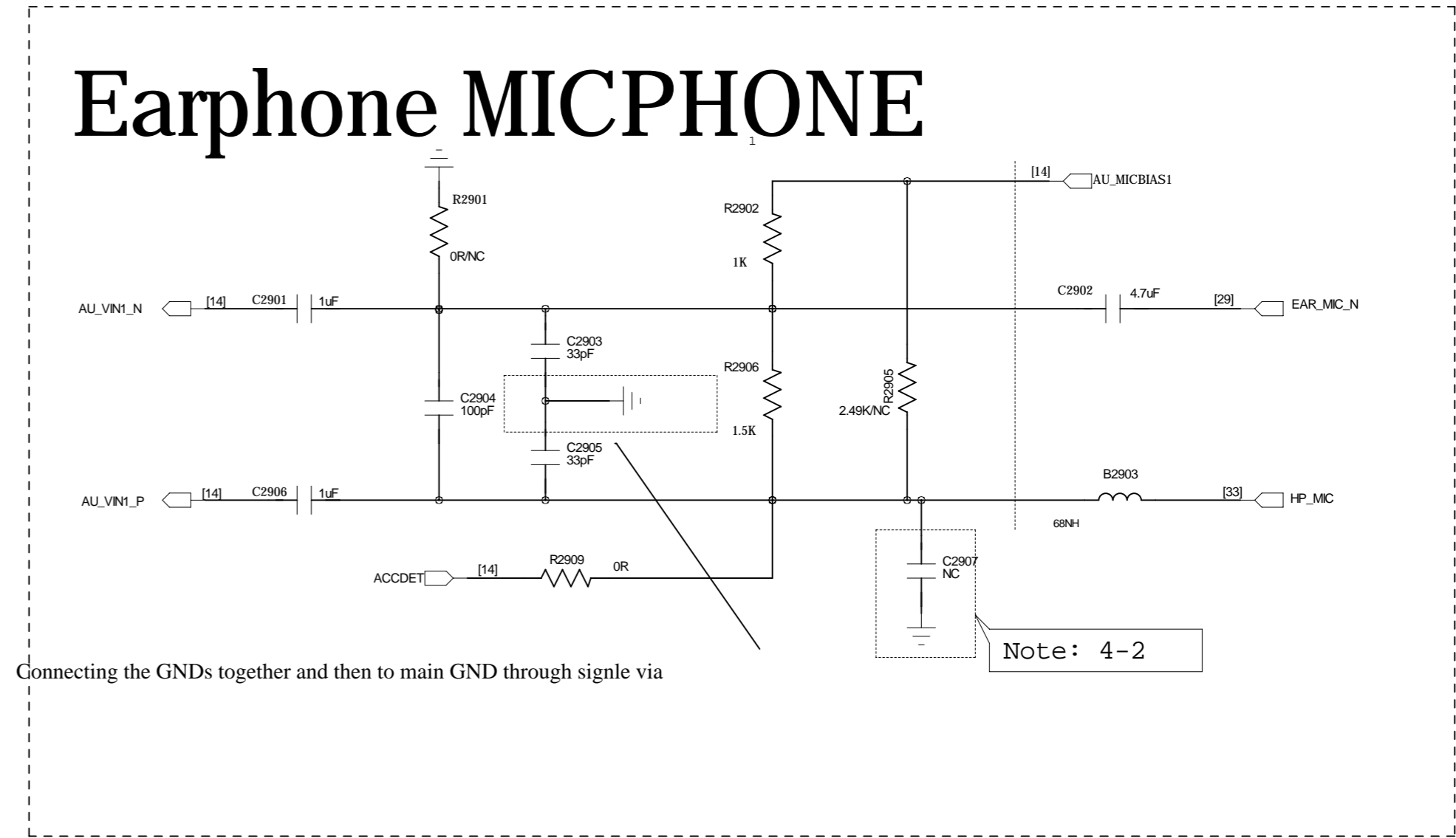
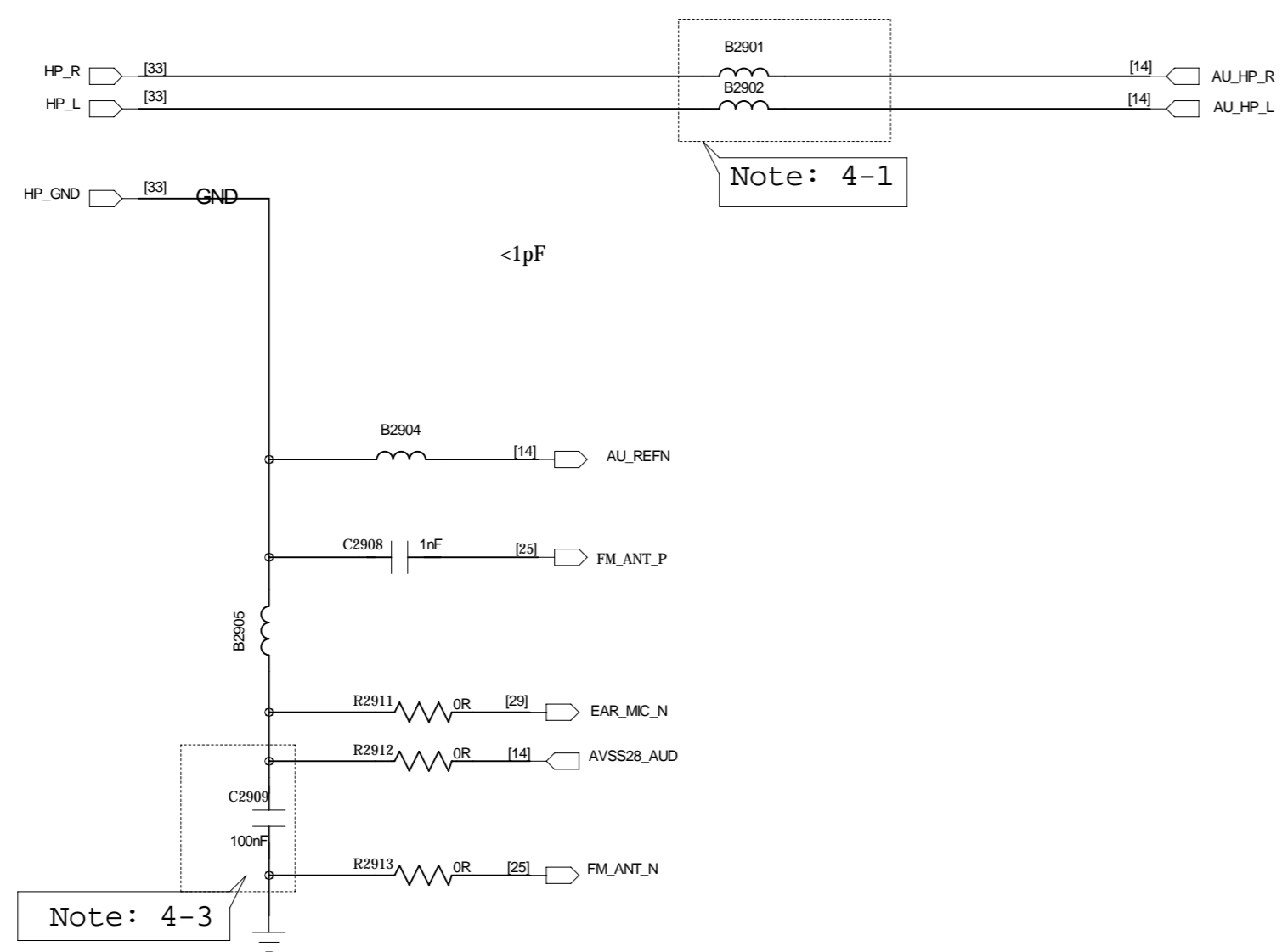

|                                     |       |       |            |                                  |  |                                  |                        |
|-------------------------------------|-------|-------|------------|----------------------------------|--|----------------------------------|------------------------|
| COMPANY: <b>Wheatek Electronics</b> |       |       |            | MODEL: <b>TE177</b>              |  | Modified Date: <b>2022/10/21</b> |                        |
| DRAWN                               | WK/SP | DATED | 2022/09/22 | TITLE: <b>29_PERL_AUDIO_JACK</b> |  | VERSION: <b>V1.1</b>             | SHEET: <b>29 OF 36</b> |
| CHECKED                             |       | DATED |            |                                  |  |                                  |                        |

# Main LCM

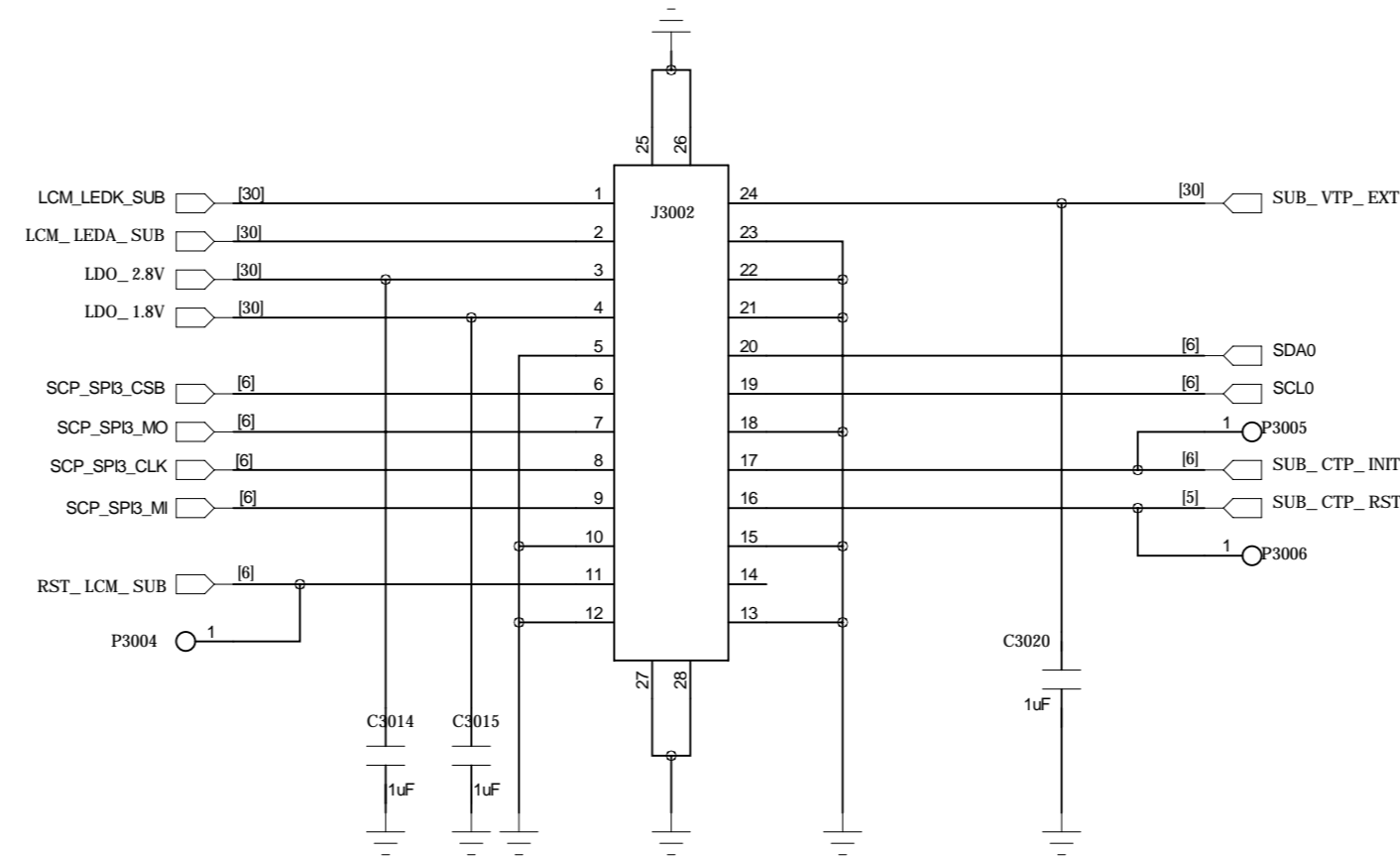
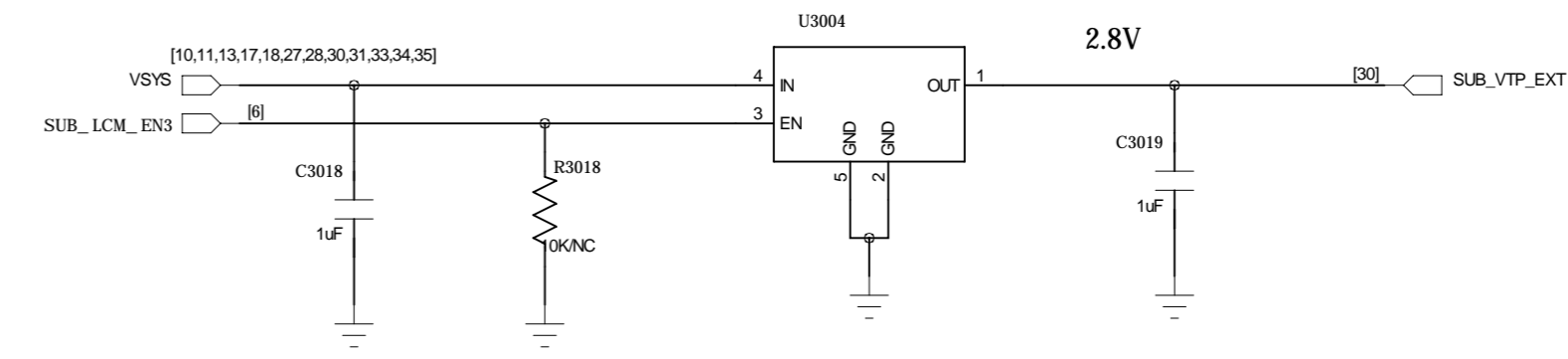
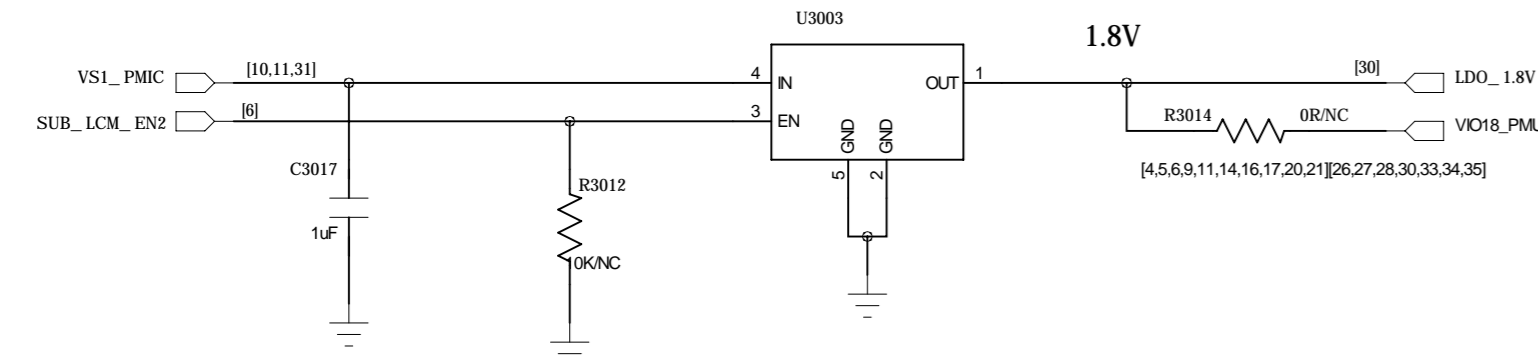
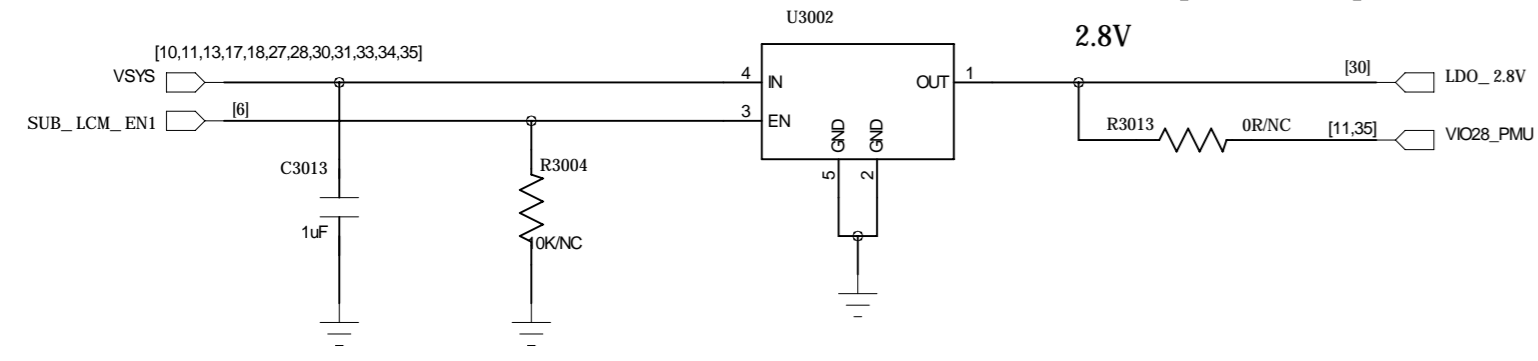
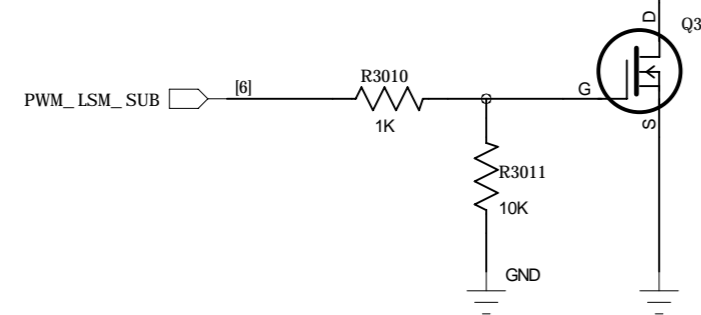
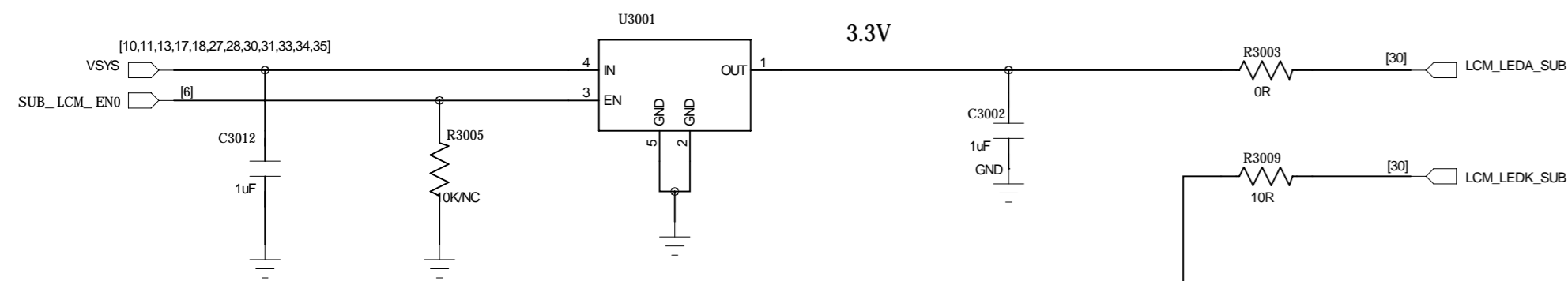
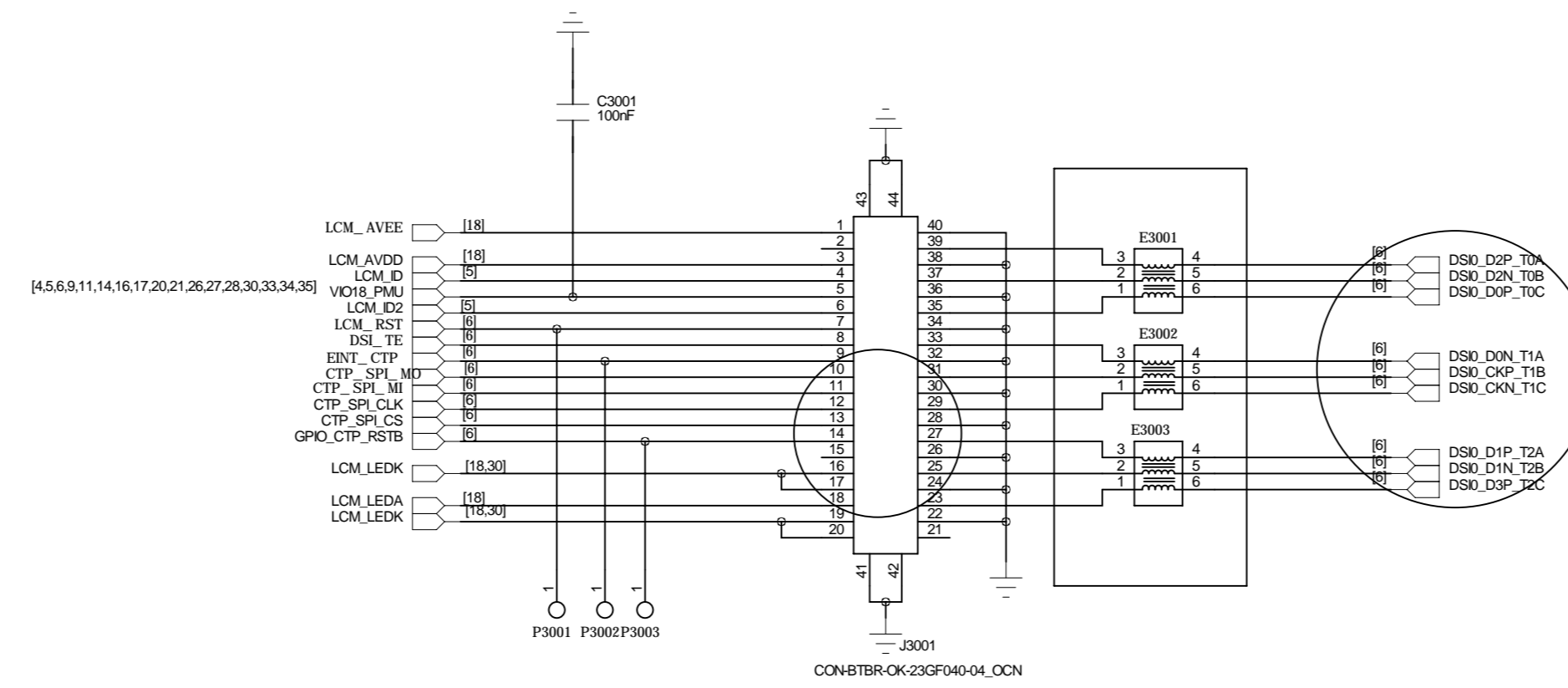

|                                      |       |       |            |                           |  |                                  |                        |
|--------------------------------------|-------|-------|------------|---------------------------|--|----------------------------------|------------------------|
| COMPANY: <b>Wheatek Inc. / TE177</b> |       |       |            | MODEL: <b>TE177</b>       |  | Modified Date: <b>2022/10/21</b> |                        |
| DRAWN                                | WK/SP | DATED | 2022/09/22 | TITLE: <b>30_PERI_LCD</b> |  | VERSION: <b>V1.1</b>             | SHEET: <b>30 OF 36</b> |
| CHECKED                              |       | DATED |            |                           |  |                                  |                        |

Rear Camera - 50M

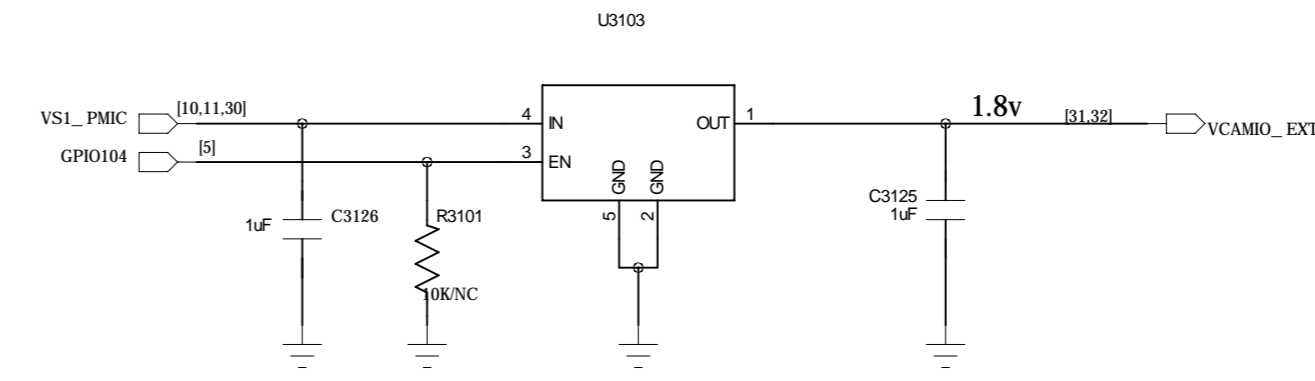
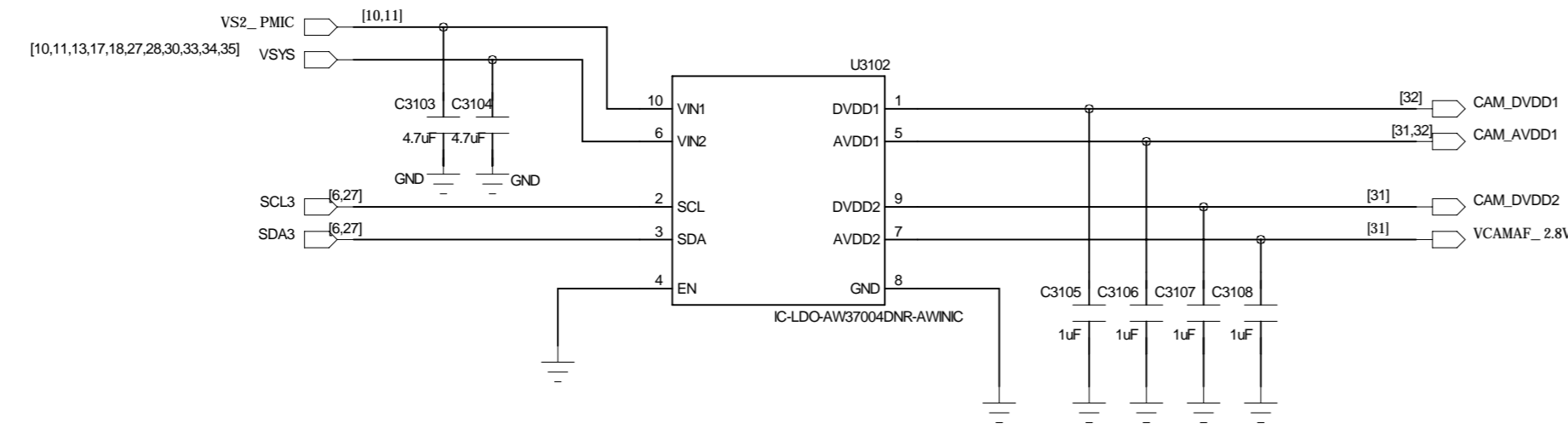

Rear Camera - 8M

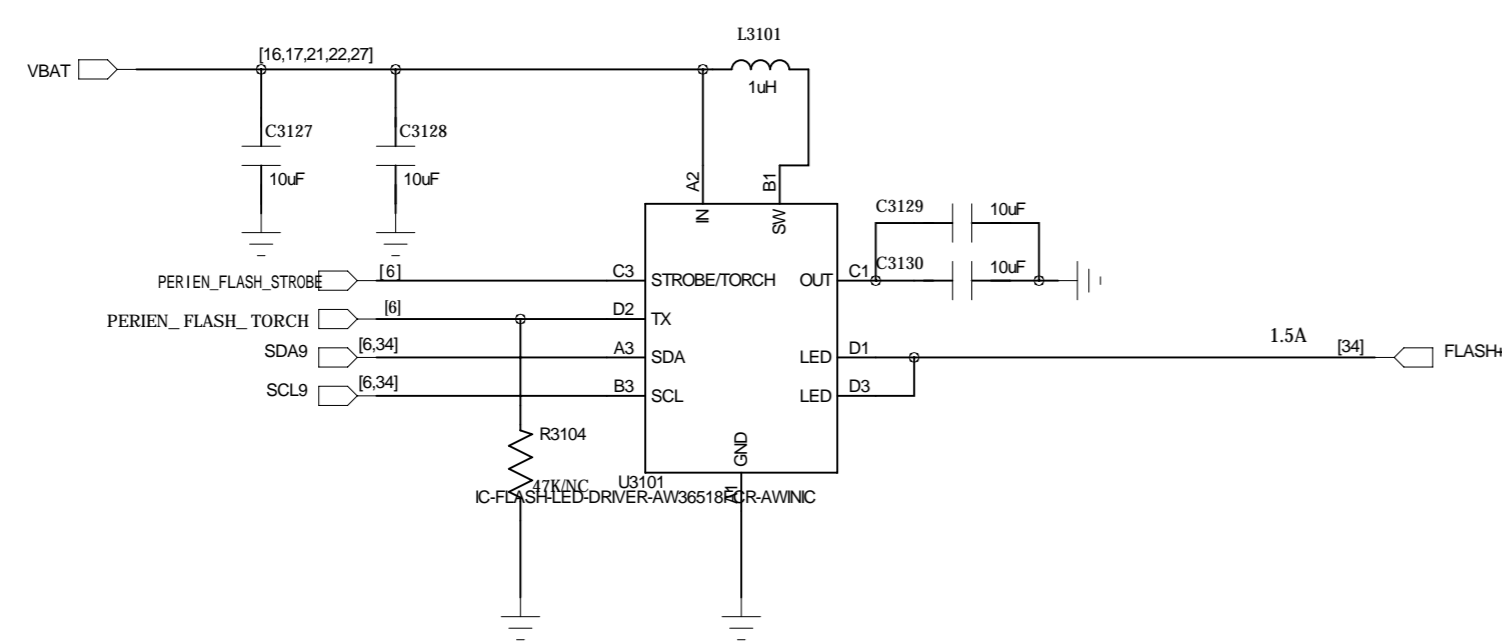
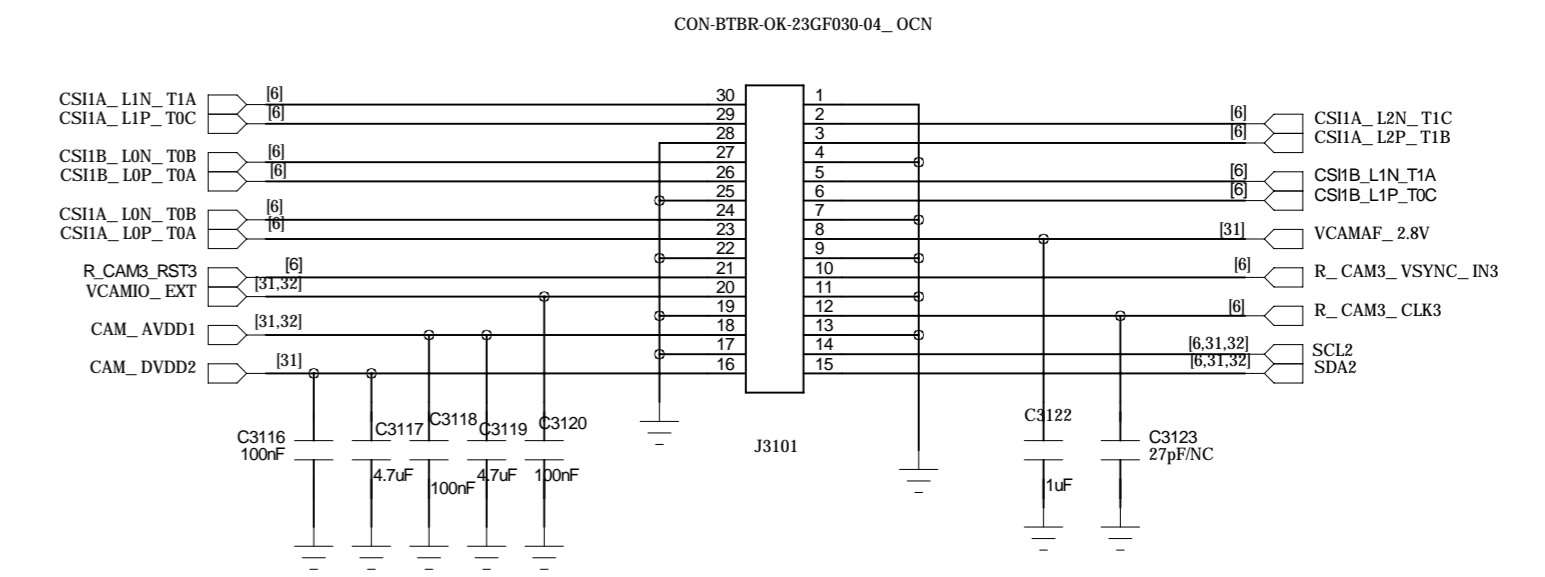
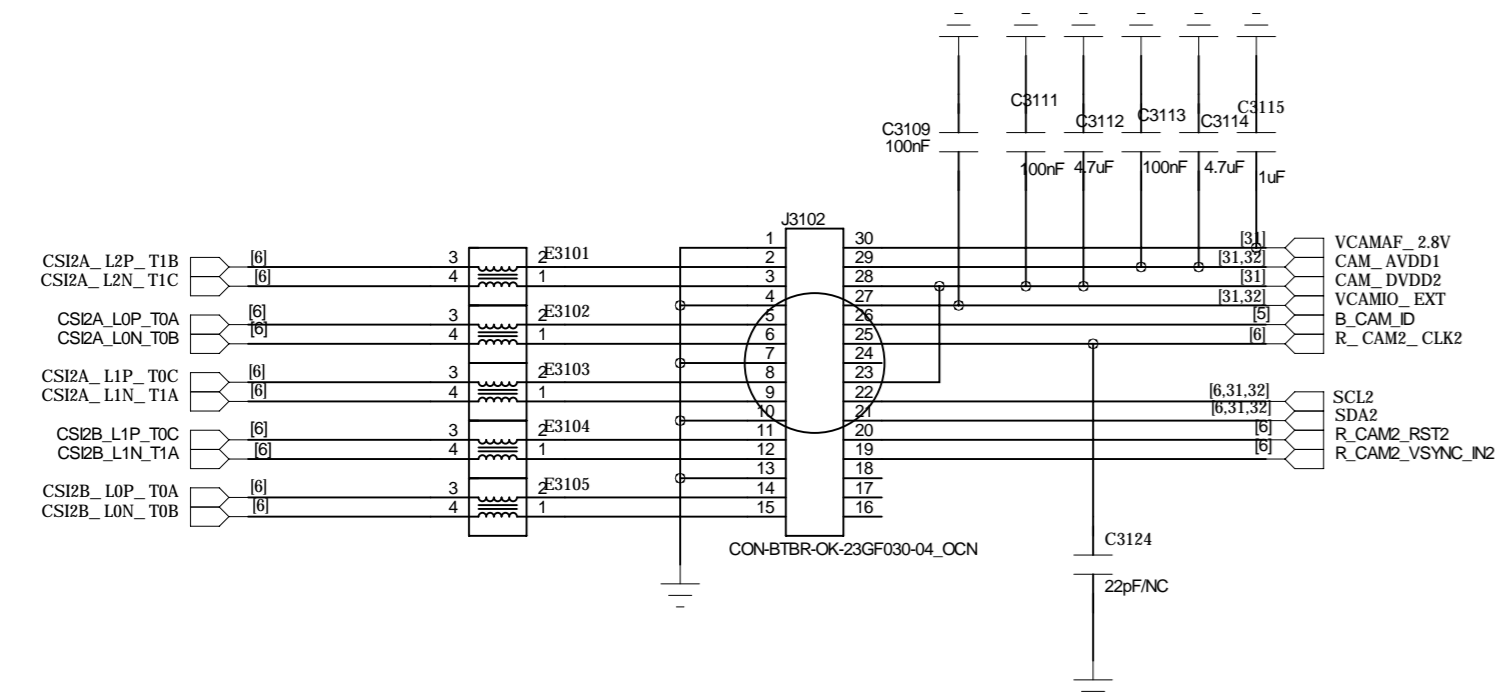

I2C:0X63

|  |       |       |            |                                   |  |                                  |                        |
|--|-------|-------|------------|-----------------------------------|--|----------------------------------|------------------------|
| COMPANY: <b>Wheatek Technology Co., Ltd.</b> |       |       |            | MODEL: <b>TE177</b>               |  | Modified Date: <b>2022/10/21</b> |                        |
| DRAWN  | WK/SP | DATED | 2022/09/22 | TITLE: <b>31_PERI_CAMERA_REAR</b> |  | VERSION: <b>V1.1</b>             | SHEET: <b>31 OF 36</b> |
| CHECKED                                      |       | DATED |            |                                   |  |                                  |                        |

Front Camera - 32M

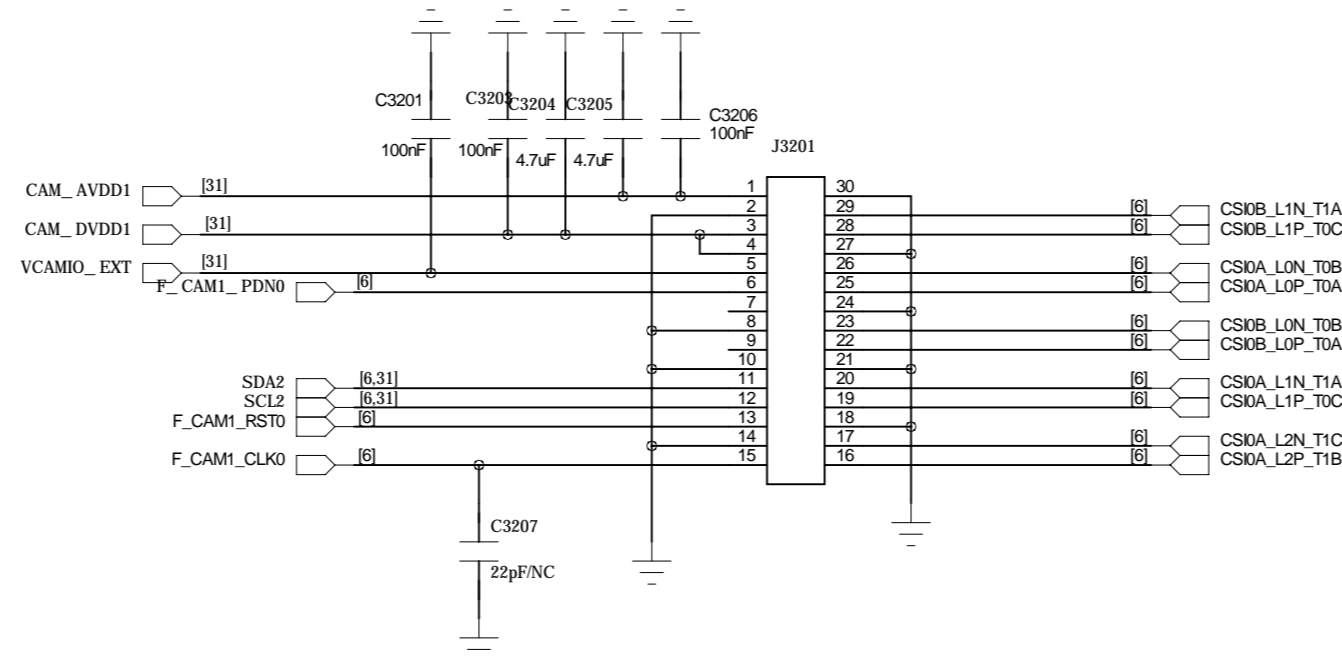

|                                     |       |       |            |                                    |   |                                  |                        |
|-------------------------------------|-------|-------|------------|------------------------------------|---|----------------------------------|------------------------|
| COMPANY: <b>Wheatek Electronics</b> |       |       |            | MODEL: <b>TE177</b>                |   | Modified Date: <b>2022/10/21</b> |                        |
| DRAWN                               | WK/SP | DATED | 2022/09/22 | TITLE: <b>32_PERI_CAMERA_FRONT</b> |   | VERSION: <b>V1.1</b>             | SHEET: <b>32 OF 36</b> |
| 4                                   |       |       | 3          |                                    | 2 |                                  | 1                      |



# Fingerprint Connector

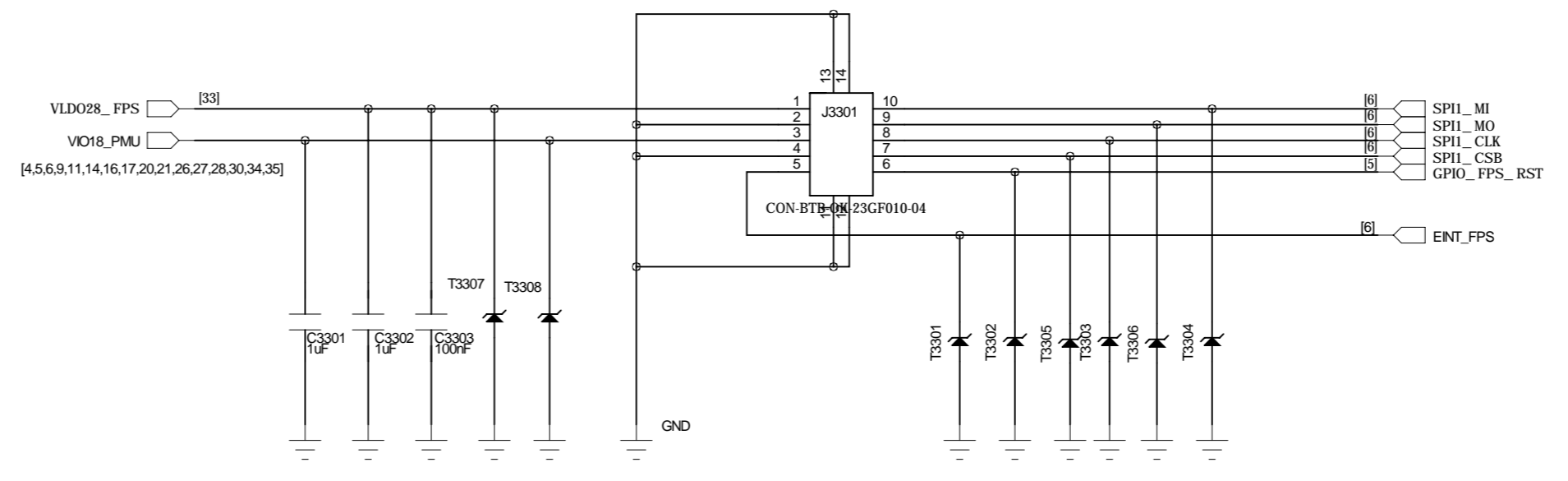

# SUB

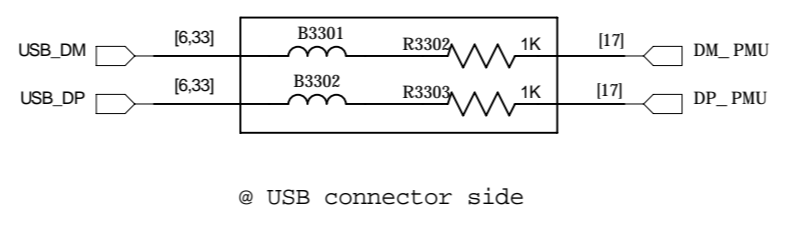
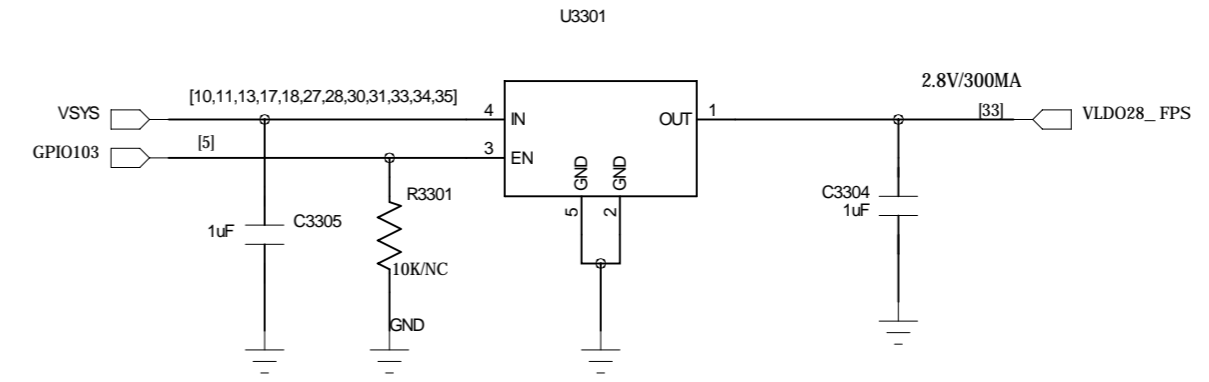
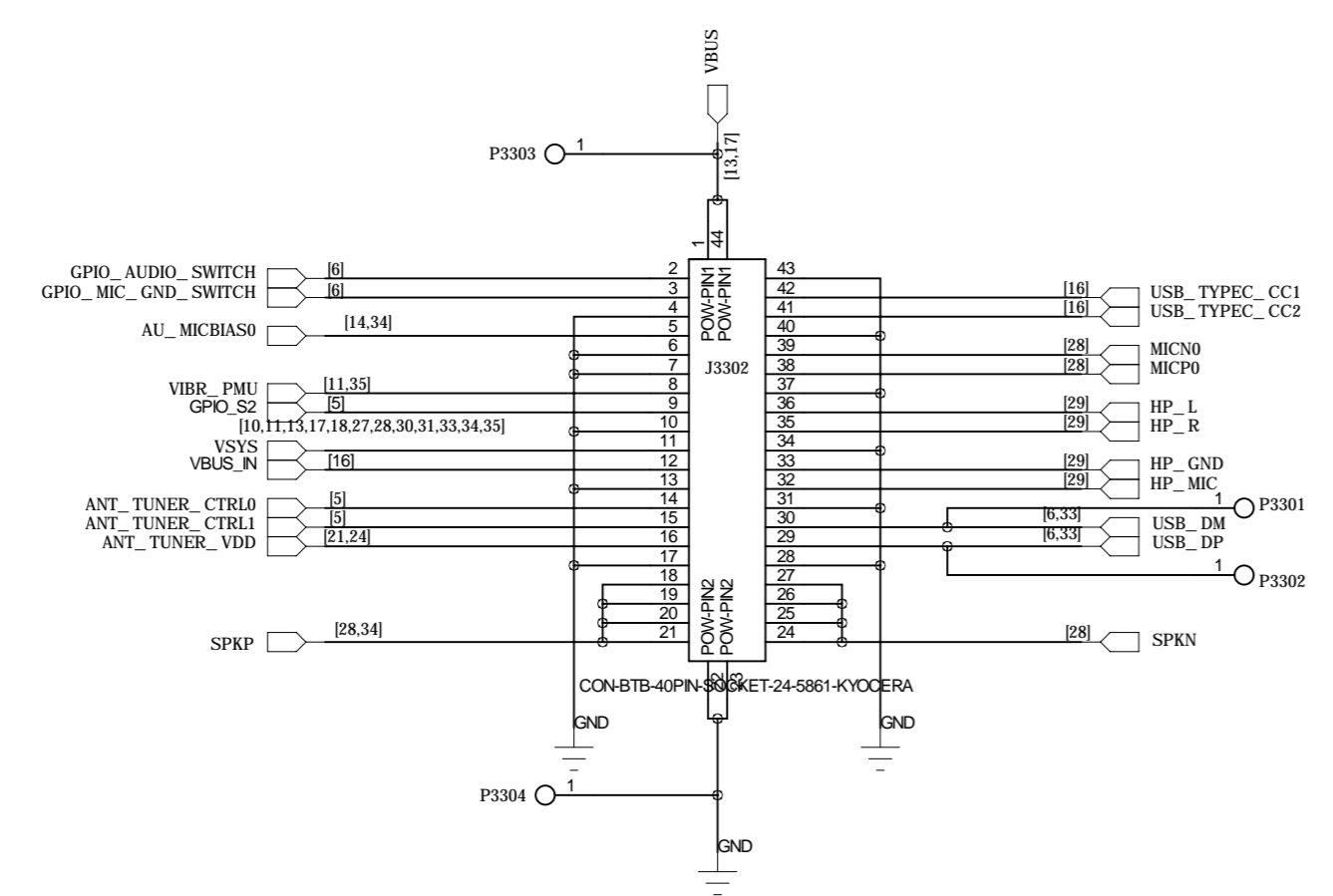

|                                     |       |       |                   |                           |                                  |                        |
|-------------------------------------|-------|-------|-------------------|---------------------------|----------------------------------|------------------------|
| COMPANY: <b>Wheatek Electronics</b> |       |       |                   | MODEL: <b>TE177</b>       | Modified Date: <b>2022/10/21</b> |                        |
| DRAWN                               | WK/SP | DATED | <b>2022/09/22</b> | TITLE: <b>33_PERI_SUB</b> |                                  | VERSION: <b>V1.1</b>   |
| CHECKED                             |       | DATED |                   |                           |                                  | SHEET: <b>33 OF 36</b> |
|                                     |       |       | <b>4</b>          | <b>3</b>                  | <b>2</b>                         | <b>1</b>               |

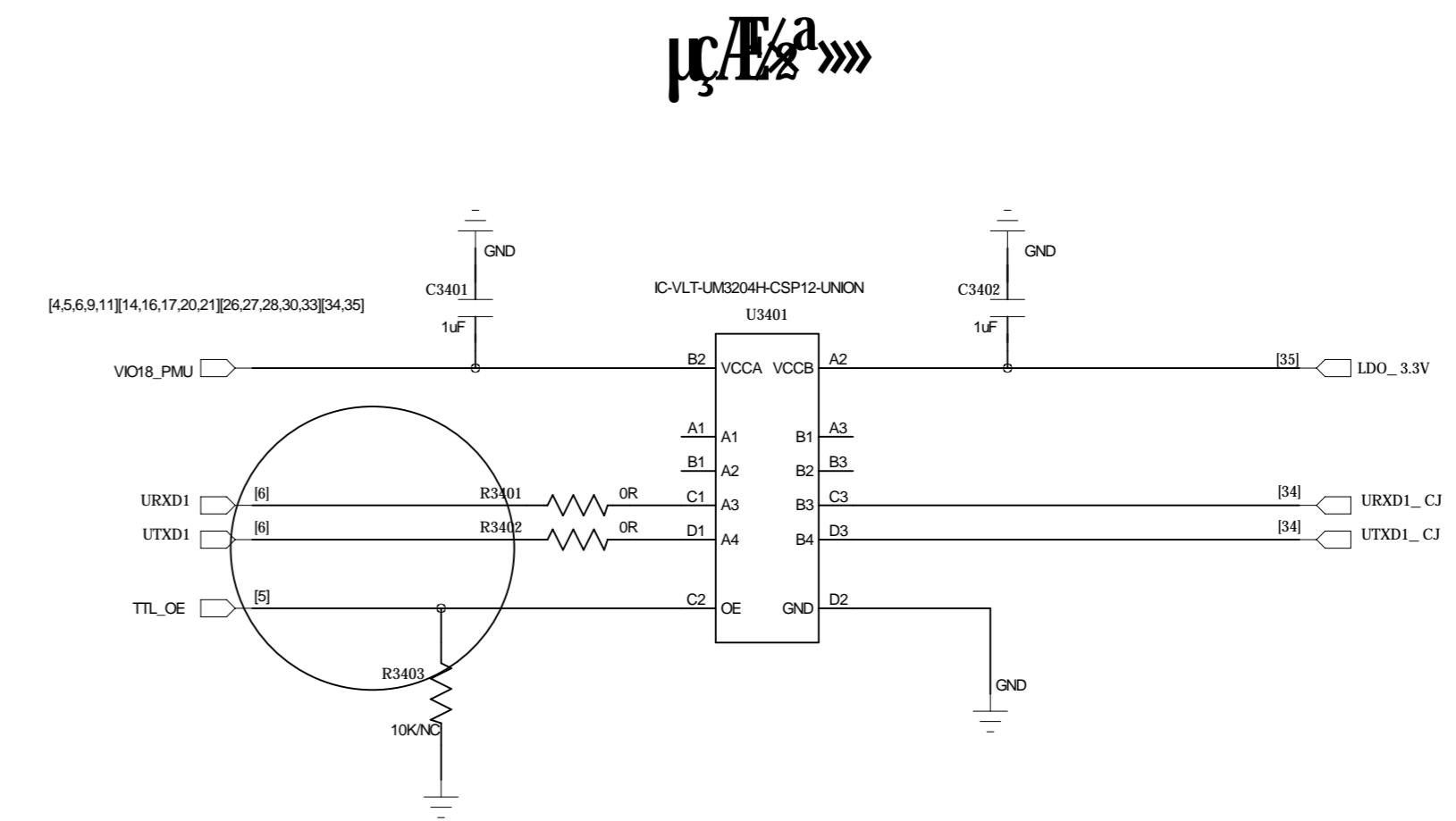
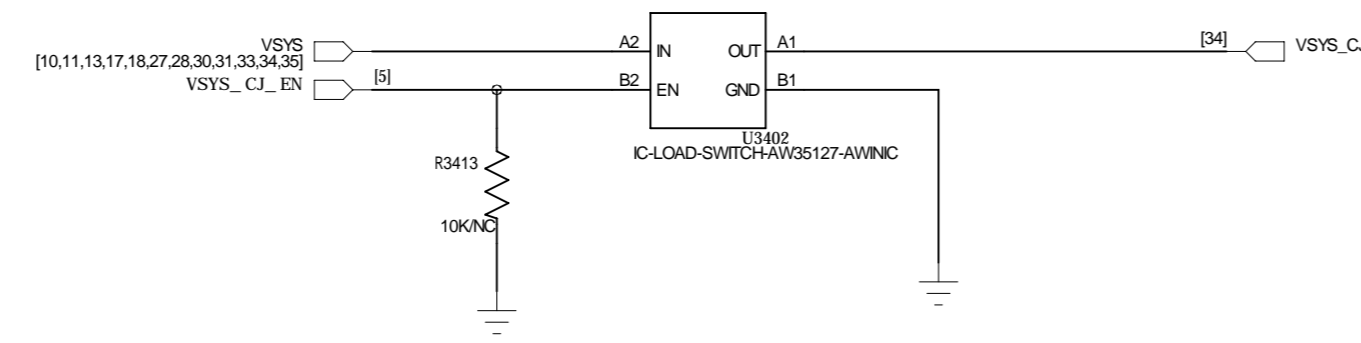

ΕΝΙΕ, ΑΟ+·ΩΣμΕ ΕΑΐμΕ ²α³α

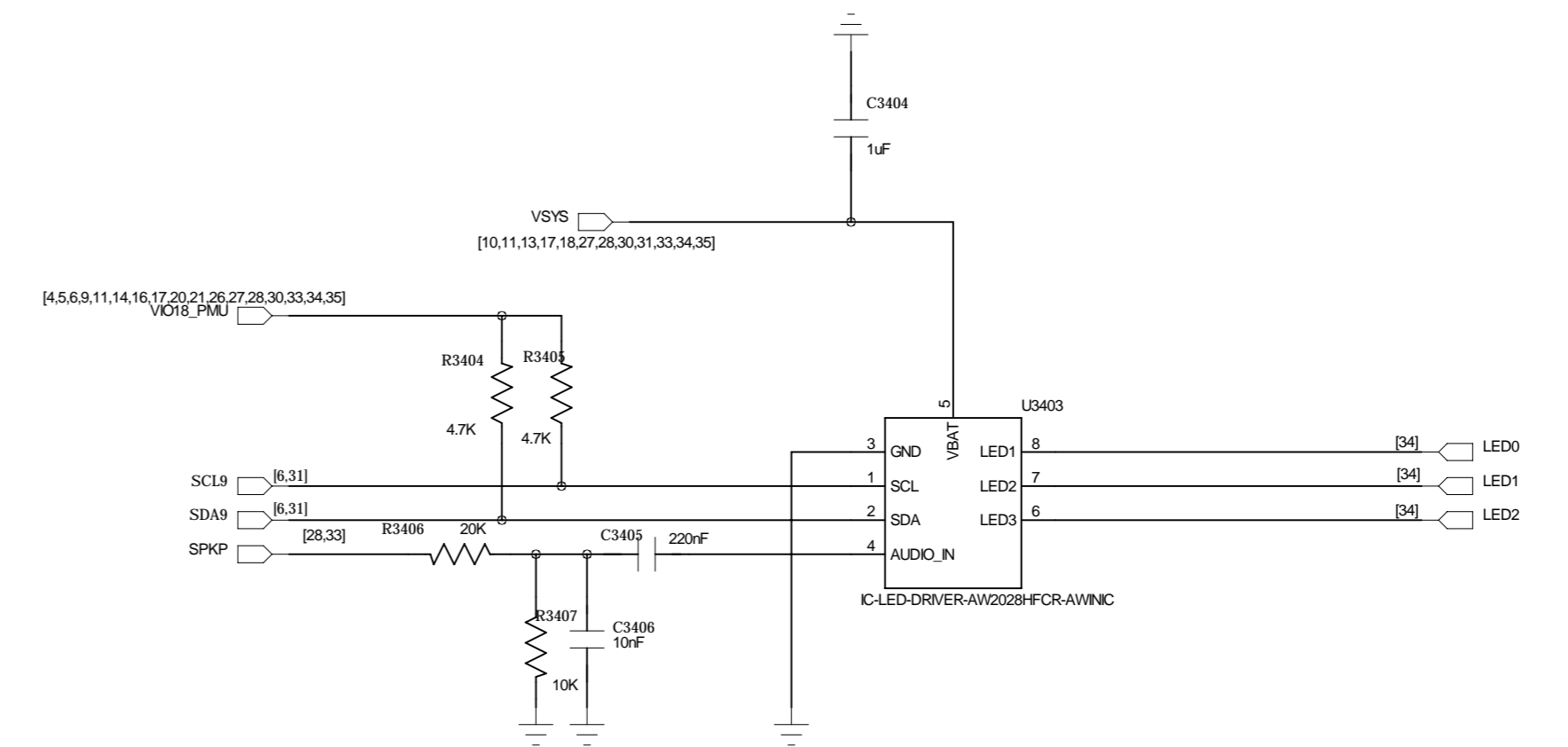
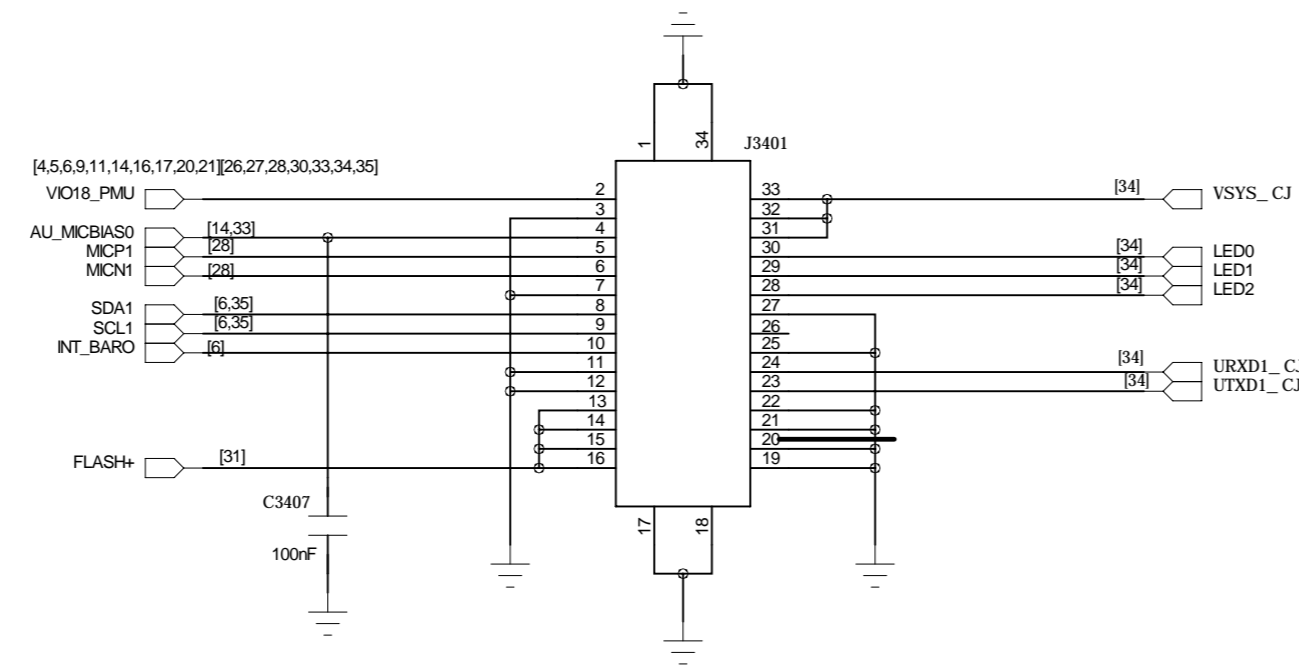

|                                 |       |       |            |                     |  |                           |                 |
|---------------------------------|-------|-------|------------|---------------------|--|---------------------------|-----------------|
| COMPANY: <b>Wheatek Π Ο Α Ε</b> |       |       |            | MODEL: <b>TE177</b> |  | Modified Date: 2022/10/21 |                 |
| DRAWN                           | WK/SP | DATED | 2022/09/22 | TITLE: 34_PERI_CJ   |  | VERSION: V1.1             | SHEET: 34 OF 36 |
| CHECKED                         |       | DATED |            |                     |  |                           |                 |

# Ambient light Proximity sensor and Front Flash

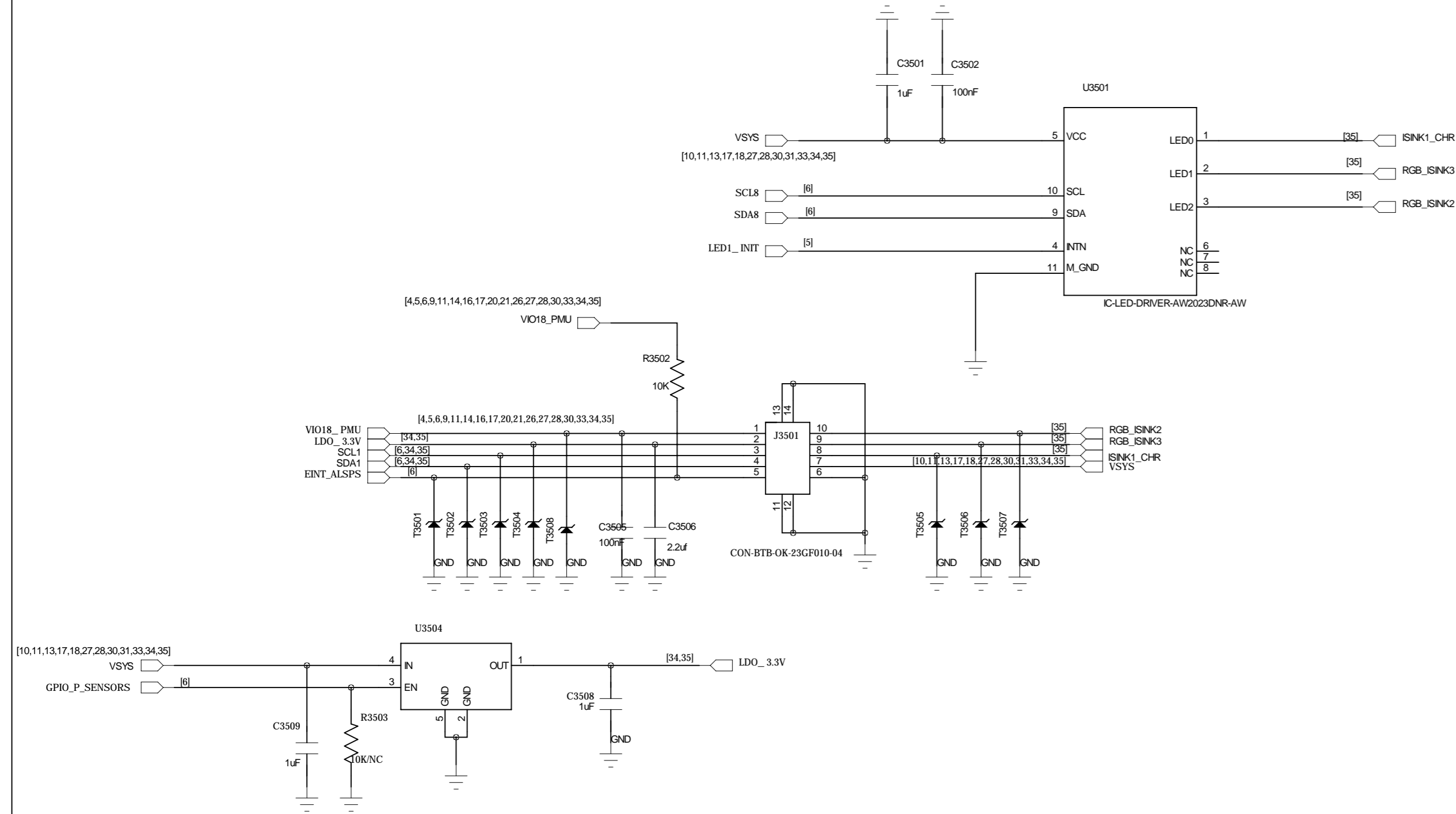

# Compass

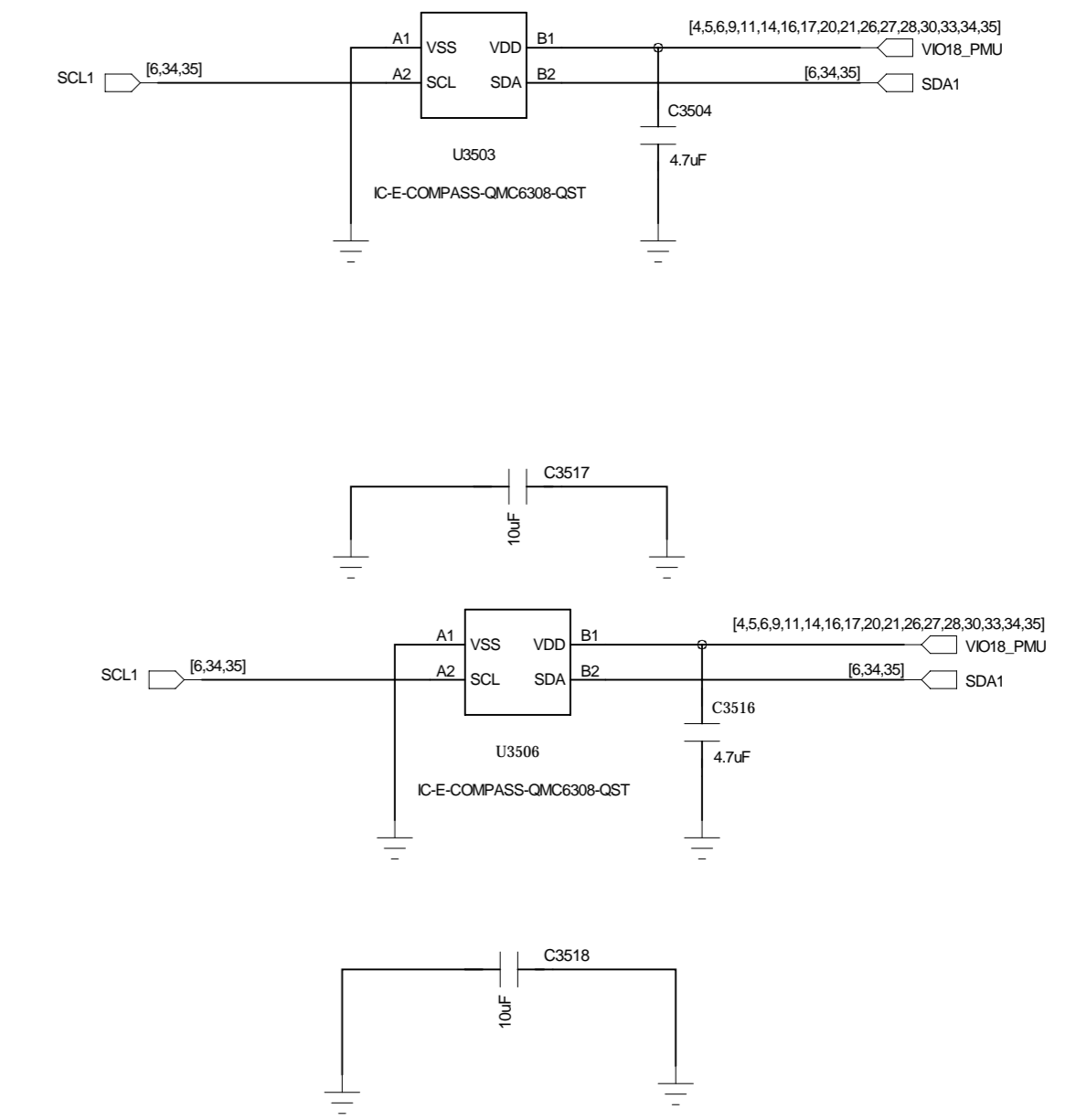

# G-sensor

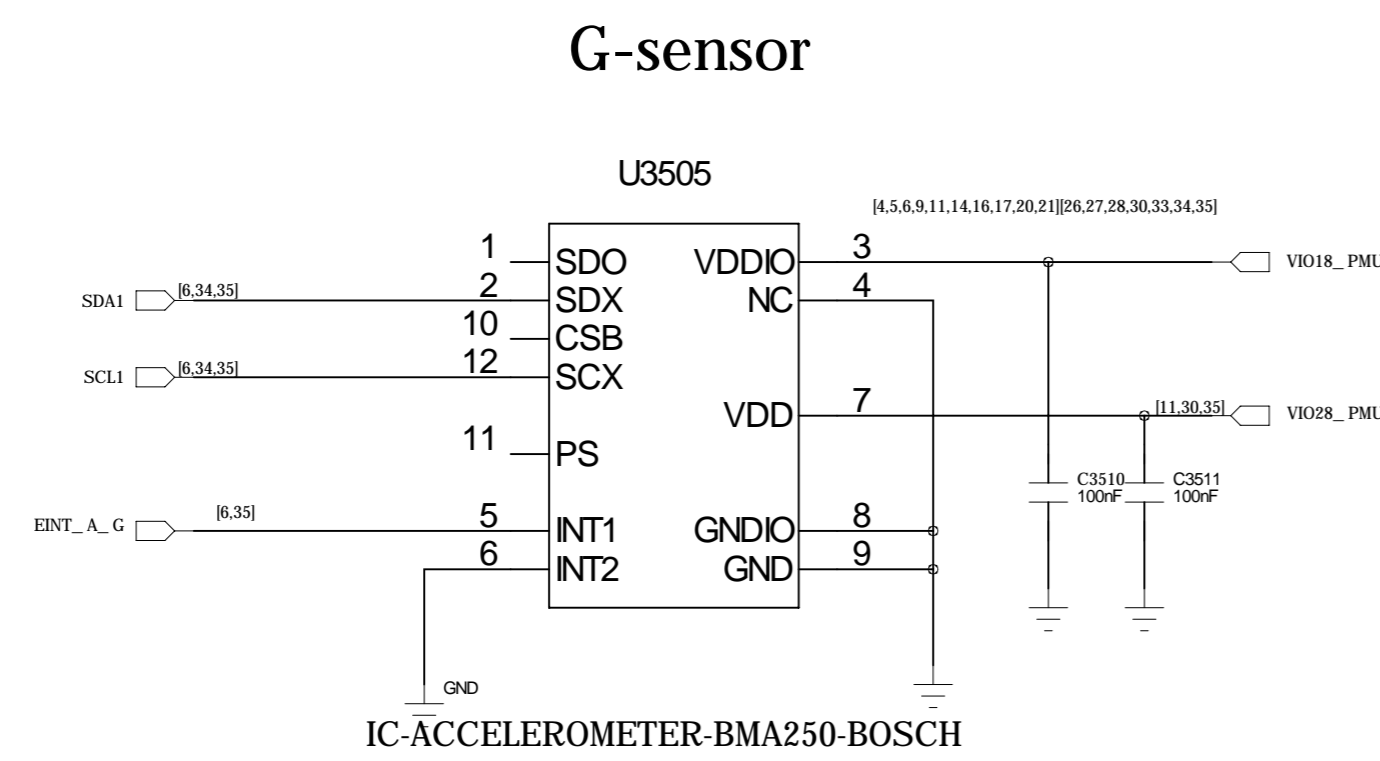

# VIB

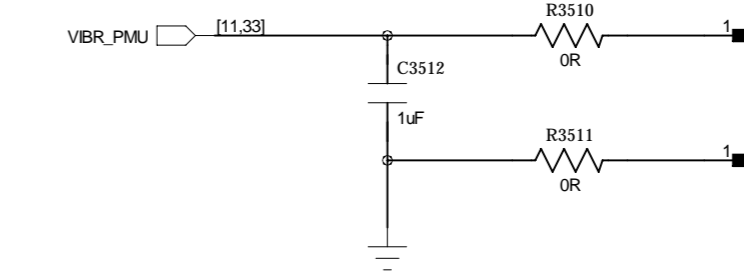

# Gyroscope

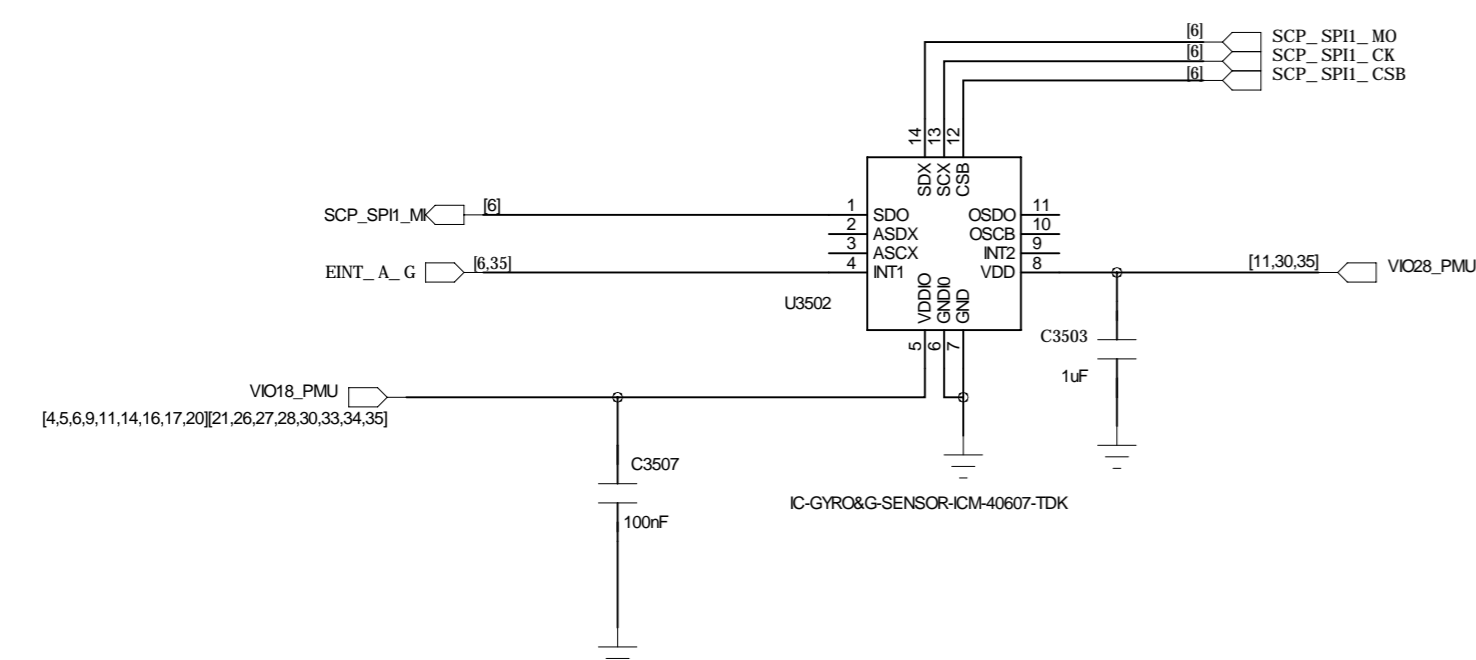

|                                      |       |       |            |   |                                  |
|--------------------------------------|-------|-------|------------|---|----------------------------------|
| COMPANY: <b>Wheatek IP Co., Ltd.</b> |       |       |            | MODEL: <b>TE177</b>                       | Modified Date: <b>2022/10/21</b> |
| DRAWN                                | WK/SP | DATED | 2022/09/22 | TITLE: <b>35_PERI_SENSORS_MEMS_ALS/PS</b> | VERSION: <b>V1.1</b>             |
| CHECKED                              |       | DATED |            |   | SHEET: <b>35 OF 36</b>           |

|                                    |       |       |            |                           |  |                                  |                        |
|------------------------------------|-------|-------|------------|---------------------------|--|----------------------------------|------------------------|
| COMPANY: <b>Wheatek Inc. / 艾特威</b> |       |       |            | MODEL: <b>TE177</b>       |  | Modified Date: <b>2022/10/21</b> |                        |
| DRAWN                              | WK/SP | DATED | 2022/09/22 | TITLE: <b>36_PERL_WPC</b> |  | VERSION: <b>V1.1</b>             | SHEET: <b>36 OF 36</b> |
| CHECKED                            |       | DATED |            |                           |  |                                  |                        |
| 4                                  |       | 3     |            | 2                         |  | 1                                |                        |