

WF-M63B-USX2 WF-M63B-USX3

IEEE 802.11a/b/g/n/ac2T2R USB WiFi Module
Integrated Bluetooth 2.1+EDR/4.2/5.1

Features:

➤ **Supported WLAN Standard**

IEEE Std. 802.11a
IEEE Std. 802.11b
IEEE Std. 802.11g
IEEE Std. 802.11n
IEEE Std. 802.11ac
Bluetooth 2.1+EDR/4.2/5.1

➤ **Chip Solution**

MediatekMT7663BUN

➤ **Size**

13.0mm x15.0mm x 2.3mm



Module	Standard	Rate	Band
WF-M63B-USX2	IEEE 802.11a/b/g/n/ac	866.7Mbps	2.4G/5G
WF-M63B-USX3	Bluetooth2.1+EDR/4.2/5.1	3Mbps	2.4G

Sichuan AI-Link Technology Co.,Ltd.

Add: Anzhou,Industrial park,Mianyang,Sichuan

tell: +86-13881190925

web : <http://www.ailinkiot.com>



Feedback of customer's Confirmation**We accept the specification after Confirmed**

Customer name	Customer signature	Confirmation Date

Please feed back this paper and first paper after your signature by the address,thanks!

ADD: Anzhou,Industrial park,Mianyang,Sichuan

Factory: Sichuan AI-Link Technology Co.,Ltd.

Approved	Checked	Designed	Product	WiFi Module
Fengyi	Fanxijun	Huanghua	Model	WF-M63B-USX2
			Date	20210813

1. Introduction

WF-M63B-USX3 module design is based on Mediatek MT7663BUN solution, The MT7663BUN is a highly integrated single chip which has built in a 2x2 dual-band wireless LAN radio and Bluetooth radio. It includes Bluetooth EDR and LE radio which complies with Bluetooth v2.1+EDR, v4.2, and v5.1. The Module is a highly integrated MAC/BBP and 2.4/5GHz PA/LNA single chip which supports a 866.7Mbps PHY rate. The Module is designed to support standard-based features in the areas of security, quality of service, and international regulations, giving end users the greatest performance anytime and in any circumstance. This documentation describes the engineering requirements specification.

1.1 RF module Overview

This WLAN Moduledesign is based on Mediatek MT7663BUN. It is a highly integrated single-chip MIMO(Multiple In Multiple Out) Wireless LAN (WLAN) network interface controllercomplying with the 802.11 specification and Bluetooth over USB interface. It combines a MAC, a2T2R capable baseband,and RF in a single chip. An intelligent Wi-Fi/Bluetooth coexistence algorithm is implemented to provide the best harmonized Wi-Fi and Bluetooth radio performance.

1.2 Specification reference

This specification is based on additional references listed below.

- _ IEEE Std. 802.11a
- _ IEEE Std. 802.11b
- _ IEEE Std. 802.11g
- _ IEEE Std. 802.11n
- _ IEEE Std. 802.11ac
- _ Bluetooth 2.1+EDR/4.2/5.1

1.3 System Functions

Table1: General Specification as below:

Main Chipset	Mediatek MT7663BUN
Operating Frequency	2.4G/5G
WiFi Standard	802.11a/b/g/n/ac(2x2)
Bluetooth	2.1+EDR/4.2/5.1
Modulation	WiFi:11b: DBPSK, DQPSK and CCK and DSSS 11a/g: BPSK, QPSK, 16QAM, 64QAM and OFDM 11n: BPSK, QPSK, 16QAM, 64QAM and OFDM 11ac: BPSK, QPSK, 16QAM, 64QAM,256QAM and OFDM Bluetooth:GFSK, $\pi/4$ -DQPSK and 8-DPSK
Data rates	11b:1, 2, 5.5 and 11Mbps 11a/g:6, 9, 12, 18, 24, 36, 48 and 54 Mbps 11n: MCS0~15, up to 300Mbps 11ac: MCS0~9, Nss=2, up to 866.7Mbps
Form factor	50pins ,
Host Interface	USB 2.0/3.0/PCM
PCB Stack	4-layers design
Dimension	Typical:13.0mmx 15.0mmx 2.3mm
Antenna	external Antennas Design
Operation Temperature	-10°Cto +70°C
Storage Temperature	-40°Cto +125°C
Operation Voltage	3.3V +/-5%
Power Consumption (WIFI TX)	813mA@3.3V 5G TX NSS=2 HT20 MCS0
Power Consumption (WIFI RX)	165mA@3.3V 5G RX NSS=2 VHT80 MCS9
Power Consumption (BT TX)	82mA@3.3V
Power Consumption (BT RX)	29mA@3.3V

2. Mechanical Specification

2.1 Mechanical Outline Drawing

Typical Dimension (W x L): 13.0mmx15.00mm x 2.3mm

General tolerance: $\pm 0.2\text{mm}$

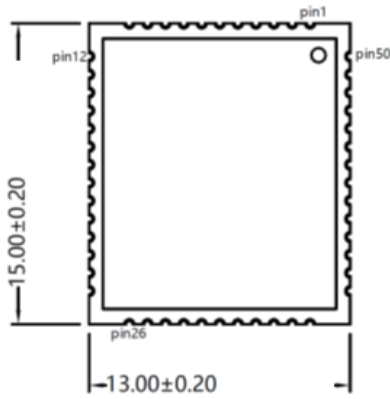

TOP VIEW

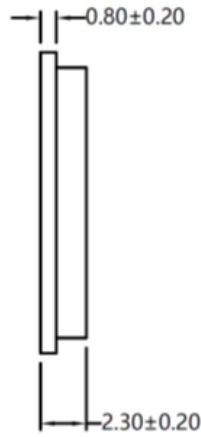

SIDE VIEW

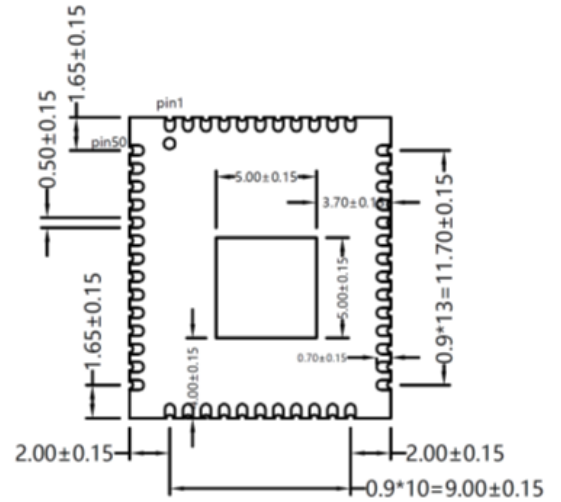

BOT VIEW

2.2 Product Picture



Topview



Botview

2.3 Pin define

Pin	Define	Pin	Define
1	GND	29	USB_RXN
2	ANT1	30	USB_RXP
3、4、5、6、 7、8	GND	31	GND
9	ANT2	32	USB_DP
10、11	GND	33	USB_DM
12	NC	34	GND
13	GND	35	NC
14	NC	36	3.3V
15	NC	37	GND
16	WIFI_WAKE	38	NC
17	NC	39	GND
18	PCM_SYNC	40	NC
19	PCM_CLK	41	NC
20	PCM_IN	42	NC
21	PCM_OUT	43	NC
22	NC	44	NC
23	GND	45	GPIO3
24	RESET	46	GND
25	GND	47	NC
26	USB_TXN	48	GND
27	USB_TXP	49	NC
28	GND	50	BT_WAKE

3. Electrical Specification

This Specification is based-on conductive DVT testing result. The extreme condition include overall temperature (0°C,+25°C,+40°C) and overall voltage (2.97V,3.3V,3.63V).

3.1 IEEE 802.11b Section:

Items	Contents				
Specification	IEEE802.11b				
Mode	DBPSK, DQPSK and CCK and DSSS				
Channel	CH1 to CH13				
Data rate	1, 2, 5.5, 11Mbps				
TX Characteristics	Min.	Typ.	Max.	Unit	Remark
1. Power Levels(Calibrated)					
1) 17dBm Target (For Each antenna port) @1Mbps~11Mbps	15	17	19	dBm	
2. Spectrum Mask @ Target Power					
1) fc +/-11MHz to +/-22MHz	-	-	-30	dBr	
2) fc > +/-22MHz	-	-	-50	dBr	
3. Constellation Error(EVM)@ Target Power					
1) 1Mbps	-	-23	-13	dB	
2) 2Mbps	-	-	-13	dB	
3) 5.5Mbps	-	-	-13	dB	
4) 11Mbps	-	-23	-13	dB	
4. Frequency Error	-10	-	10	ppm	
RX Characteristics	Min.	Typ.	Max.	Unit	
5. Minimum Input Level Sensitivity(each chain)					
1) 1Mbps (FER ≤ 8%)	-	-95	-85	dBm	
2) 2Mbps (FER ≤ 8%)	-	-	-83	dBm	
3) 5.5Mbps (FER ≤ 8%)	-	-	-81	dBm	
4) 11Mbps (FER ≤ 8%)	-	-89	-79	dBm	
6. Maximum Input Level (FER ≤ 8%)	-10	10	-	dBm	

3. 2 IEEE 802.11g/a Section:

Items	Contents				
Specification	IEEE802.11g &IEEE802.11a				
Mode	BPSK, QPSK, 16QAM, 64QAM and OFDM				
Channel	CH1 to CH13 @ 11g CH36 to CH165 @ 11a				
Data rate	6, 9, 12, 18, 24, 36, 48, 54Mbps				
TX Characteristics	Min.	Typ.	Max.	Unit	Remark
1. Power Levels					
1) 17dBm Target (For Each antenna port) @ 11g 6Mbps~48Mbps	15	17	19	dBm	
2) 15dBm Target (For Each antenna port) @ 11g 54Mbps	14	16	18	dBm	
3) 17dBm Target (For Each antenna port) @ 11a 6Mbps~48Mbps	15	17	19	dBm	
4) 15dBm Target (For Each antenna port) @ 11a 54Mbps	13	15	17	dBm	
2. Spectrum Mask @ Target Power					
1) at fc +/-11MHz	-	-	-20	dBr	
2) at fc +/-20MHz	-	-	-28	dBr	
3) at fc > +/-30MHz	-	-	-40	dBr	
3. Constellation Error(EVM)@ Target Power					
1) 6Mbps	-	-30	-8	dB	
2) 9Mbps	-	-	-11	dB	
3) 12Mbps	-	-	-13	dB	
4) 18Mbps	-	-	-16	dB	
5) 24Mbps	-	-	-19	dB	
6) 36Mbps	-	-	-23	dB	
7) 48Mbps	-	-	-25	dB	
8) 54Mbps	-	-37	-28	dB	
4. Frequency Error					
1) IEEE802.11g	-10	-	10	ppm	
2) IEEE802.11a	-10	-	10	ppm	
RX Characteristics	Min.	Typ.	Max.	Unit	
5. Minimum Input Level Sensitivity(each chain)					
1) 6Mbps (PER \leq 10%)	-	-94	-85	dBm	
2) 9Mbps (PER \leq 10%)	-	-	-84	dBm	
3) 12Mbps (PER \leq 10%)	-	-	-82	dBm	
4) 18Mbps (PER \leq 10%)	-	-	-80	dBm	
5) 24Mbps (PER \leq 10%)	-	-	-77	dBm	
6) 36Mbps (PER \leq 10%)	-	-	-73	dBm	
7) 48Mbps (PER \leq 10%)	-	-	-69	dBm	
8) 54Mbps (PER \leq 10%)	-	-76	-68	dBm	
6. Maximum Input Level (PER \leq 10%)					
1) IEEE802.11g	-20	-2	-	dBm	
2) IEEE802.11a	-30	-2	-	dBm	

3.3 IEEE 802.11nHT20 Section:

Items	Contents					
Specification	IEEE802.11n HT20 @ 2.4G IEEE802.11n HT20@ 5G					
Mode	BPSK, QPSK, 16QAM, 64QAM and OFDM					
Channel	CH1 to CH13 @ 2.4G CH36 to CH165 @ 5G					
Data rate (MCS index)	MCS0/1/2/3/4/5/6/7/8/9/10/11/12/13/14/15					
TX Characteristics		Min.	Typ.	Max.	Unit	Remark
1. Power Levels						
1) 17dBm Target (For Each antenna port) @ 2.4G/MCS0~MCS6	15	17	19	dBm		
2) 15dBm Target (For Each antenna port) @ 2.4G/MCS7	14	16	18	dBm		
3) 17dBm Target (For Each antenna port) @ 5G/MCS0~MCS6	15	17	19	dBm		
4) 15dBm Target (For Each antenna port) @ 5G/MCS7	13	15	17	dBm		
2. Spectrum Mask@ Target Power						
1) at fc +/-11MHz	-	-	-20	dBr		
2) at fc +/-20MHz	-	-	-28	dBr		
3) at fc > +/-30MHz	-	-	-45	dBr		
3. Constellation Error(EVM)@ Target Power						
1) MCS0	-	-30	-8	dB		
2) MCS1	-	-	-13	dB		
3) MCS2	-	-	-16	dB		
4) MCS3	-	-	-19	dB		
5) MCS4	-	-	-22	dB		
6) MCS5	-	-	-25	dB		
7) MCS6	-	-	-28	dB		
8) MCS7	-	-38	-30	dB		
4. Frequency Error						
1) IEEE802.11n HT20 @ 2.4G	-10	-	10	ppm		
2)IEEE802.11n HT20@ 5G	-10	-	10	ppm		
RX Characteristics		Min.	Typ.	Max.	Unit	
5. Minimum Input Level Sensitivity(each chain)						
1) MCS0 (PER \leq 10%)	-	-94	-85	dBm		
2) MCS1 (PER \leq 10%)	-	-	-82	dBm		
3) MCS2 (PER \leq 10%)	-	-	-80	dBm		
4) MCS3 (PER \leq 10%)	-	-	-77	dBm		
5) MCS4 (PER \leq 10%)	-	-	-73	dBm		
6) MCS5 (PER \leq 10%)	-	-	-69	dBm		
7) MCS6 (PER \leq 10%)	-	-	-68	dBm		
8) MCS7 (PER \leq 10%)	-	-74	-67	dBm		
6. Maximum Input Level (PER \leq 10%)						
1) IEEE802.11n HT20 @ 2.4G	-20	-2	-	dBm		
2)IEEE802.11n HT20@ 5G	-30	-2	-	dBm		

3.4 IEEE 802.11nHT40 Section:

Items	Contents					
Specification	IEEE802.11n HT40 @ 2.4G IEEE802.11n HT40@ 5G					
Mode	BPSK, QPSK, 16QAM, 64QAM and OFDM					
Channel	CH3 to CH11 @ 2.4G CH38 to CH163 @ 5G					
Data rate (MCS index)	MCS0/1/2/3/4/5/6/7/8/9/10/11/12/13/14/15					
TX Characteristics		Min.	Typ.	Max.	Unit	Remark
1. Power Levels (Calibrated)						
1) 17dBm Target (For Each antenna port) @ 2.4G/MCS0~MCS6	15	17	19	dBm		
2) 15dBm Target (For Each antenna port) @ 2.4G/MCS7	14	16	18	dBm		
3) 17dBm Target (For Each antenna port) @ 5G/MCS0~MCS6	15	17	19	dBm		
4) 15dBm Target (For Each antenna port) @ 5G/MCS7	13	15	17	dBm		
2. Spectrum Mask@Target Power						
1) at fc +/-21MHz	-	-	-20	dB		
2) at fc +/-40MHz	-	-	-28	dB		
3) at fc > +/-60MHz	-	-	-45	dB		
3. Constellation Error(EVM)@Target Power						
1) MCS0	-	-30	-8	dB		
2) MCS1	-	-	-13	dB		
3) MCS2	-	-	-16	dB		
4) MCS3	-	-	-19	dB		
5) MCS4	-	-	-22	dB		
6) MCS5	-	-	-25	dB		
7) MCS6	-	-	-28	dB		
8) MCS7	-	-38	-30	dB		
4. Frequency Error						
1) IEEE802.11n HT20 @ 2.4G	-10	-	10	ppm		
2)IEEE802.11n HT20@ 5G	-10	-	10	ppm		
RX Characteristics		Min.	Typ.	Max.	Unit	
5. Minimum Input Level Sensitivity(each chain)						
1) MCS0 (PER \leq 10%)	-	-90	-82	dBm		
2) MCS1 (PER \leq 10%)	-	-	-79	dBm		
3) MCS2 (PER \leq 10%)	-	-	-77	dBm		
4) MCS3 (PER \leq 10%)	-	-	-74	dBm		
5) MCS4 (PER \leq 10%)	-	-	-70	dBm		
6) MCS5 (PER \leq 10%)	-	-	-66	dBm		
7) MCS6 (PER \leq 10%)	-	-	-65	dBm		
8) MCS7 (PER \leq 10%)	-	-71	-64	dBm		
6. Maximum Input Level(PER \leq 10%)						
1) IEEE802.11n HT20 @ 2.4G	-20	-2	-	dBm		
2)IEEE802.11n HT20@ 5G	-30	-2	-	dBm		

3.5 IEEE 802.11ac Section:

Items	Contents							
Specification	IEEE802.11ac							
Mode	BPSK, QPSK, 16QAM, 64QAM ,256QAM and OFDM							
Channel	CH36 to CH165 VHT20 CH38 to CH163 VHT40 CH42 to CH157 VHT80							
Data rate (MCS index)	MCS0/1/2/3/4/5/6/7/8/9							
TX Characteristics	Min.	Typ.			Max.		Unit	Remark
1. Power Levels (Calibrated)								
1) 17dBm Target (For Each antenna port) @VHT20/VHT40/VHT80 MCS0~MCS6	15	17			19		dBm	
2) 15dBm Target (For Each antenna port) @VHT20/VHT40/VHT80 MCS7	13	15			17		dBm	
3) 14dBm Target (For Each antenna port) @VHT20/VHT40/VHT80 MCS8~MCS9	12	14			16		dBm	
2. Spectrum Mask @Target Power								
1) at fc +/-11MHz /20MHz/30MHz	-	-			-20		dBr	
2) at fc +/-21MHz /40MHz/60MHz	-	-			-28		dBr	
3) at fc +/-41MHz /80MHz/120MHz	-	-			-40		dBr	
3. Constellation Error(EVM)@Target Power								
1) MCS0	-	-			-8		dB	
2) MCS1	-	-			-13		dB	
3) MCS2	-	-			-16		dB	
4) MCS3	-	-			-19		dB	
5) MCS4	-	-			-22		dB	
6) MCS5	-	-			-25		dB	
7) MCS6	-	-			-28		dB	
8) MCS7	-	-			-30		dB	
9) MCS8	-	-			-32		dB	
10) MCS9	-	-36			-33		dB	
4. Frequency Error	-10	-			10		ppm	
RX Characteristics	Min.	Typ.			Max.		Unit	
5. Minimum Input Level Sensitivity(each chain)		VHT 20	VHT 40	VHT 80	VHT 20	VHT 40	VHT 80	
1) MCS0 (PER ≤ 10%)	-	-94	-90	-87	-85	-82	-79	dBm
2) MCS1 (PER ≤ 10%)	-	-	-	-	-82	-79	-76	dBm
3) MCS2 (PER ≤ 10%)	-	-	-	-	-80	-77	-74	dBm
4) MCS3 (PER ≤ 10%)	-	-	-	-	-77	-74	-71	dBm
5) MCS4 (PER ≤ 10%)	-	-	-	-	-73	-70	-67	dBm
6) MCS5 (PER ≤ 10%)	-	-	-	-	-69	-67	-63	dBm
7) MCS6 (PER ≤ 10%)	-	-	-	-	-68	-65	-62	dBm
8) MCS7 (PER ≤ 10%)	-	-	-	-	-67	-64	-61	dBm
9) MCS8 (PER ≤ 10%)	-	-	-	-	-62	-59	-56	dBm
10) MCS9 (PER ≤ 10%)	-	-70	-65	-63	-60	-57	-54	dBm
6. Maximum Input Level(PER ≤ 10%)	-30	-2	-2	-2	-			dBm

3.6 BluetoothSection:

3.6.1 BR Specification

Items	Contents				
Host Interface	USB				
Channel	CH0 to CH78				
Modulation	GFSK				
	Min.	Typ.	Max.	Unit	
TX Characteristics					
1.Output Average Power	9	13	17	dBm	
2.Modulation Characteristics					
1)Delta f1(Avg)		157		kHz	
2)Delta f2max(For at least 99.9% of all Delta f2max)		121		kHz	
3)Delta f2/ Delta f1		0.85		kHz	
3.Initial Carrier Frequency Tolerance		+/-20	-	kHz	
4. Carrier Frequency Drift					
1) One Slot packet drift (DH1)		+/-15		kHz	
2) Three Slot packet drift (DH3)		+/-15		kHz	
3) Five Slot packet drift (DH5)		+/-15		kHz	
4)Max Drift Rate		+/-15		kHz/50us	
RX Characteristics					
1. ReceiverSensitivity (BER<0.1%)		-94		dBm	
2. Maximum usable signal (BER<0.1%)		-5		dBm	

3.6.2 EDR Specification

Items	Contents				
Host Interface	USB				
Channel	CH0 to CH78				
Modulation	$\pi/4$ -DQPSK、8PSK				
	Min.	Typ.	Max.	Unit	
TX Characteristics	6	10	14		
1.Relative Transmit Power					
1) $\pi/4$ -DQPSK		-1.5		dBm	
2) 8PSK		-1.5		dBm	
2. Frequency Stability				kHz	
1) Omega-i		+/-4		kHz	
2) Omega-0		+/-4	-	kHz	
3) Omega-0 + Omega-i		+/-4			
3. Modulation Accuracy					
1) RMS DEVM					
$\pi/4$ -DQPSK		+/-9		%	
8PSK		+/-9		%	
2) Peak DEVM					
$\pi/4$ -DQPSK		+/-28		%	
8PSK		+/-21		%	
3) 99% DEVM					
$\pi/4$ -DQPSK		+/-15		%	
8PSK		+/-12		%	
RX Characteristics					
1. ReceiverSensitivity (BER<0.01%)					
1) $\pi/4$ -DQPSK		-91		dBm	
2) 8PSK		-89		dBm	
2. Maximum usable signal (BER<0.1%)					
1) $\pi/4$ -DQPSK		-5		dBm	
2) 8PSK		-5		dBm	

3.6.3 LE Specification

Items	Contents				
Host Interface	UART				
Channel	CH0 to CH39				
	Min.	Typ.	Max.	Unit	
TX Characteristics					
1. Output power at NOC	9	13	17	dBm	
2. Modulation Characteristics					
1)Delta f1(Avg)	225		275	kHz	
2)Delta f2max(For at least 99.9% of all Delta f2max)	185			kHz	
3)Delta f2/ Delta f1	0.8	0.94		Hz/Hz	
3. Carrier frequency offset and drift					
1) Frequency Offset	-150		150	kHz	
2) Frequency Drift	-50		50	kHz	
3) Max Drift Rate	-20		20	Hz/us	
4. In-band Spurious Emissions					
1) +/-2M offset			-20	dBm	
2) > +/-3MHz offset			-30	dBm	
RX Characteristics					
1. Receiver Sensitivity (BER<30.8%)		-95		dBm	
2. Maximum usable signal (BER<30.8%)		-5		dBm	

4. Reference Design

4.1 SCH

4.2 Recommend PCB Layout Decal

5. Host Interface Timing Diagram

5.1 Chip power on sequence

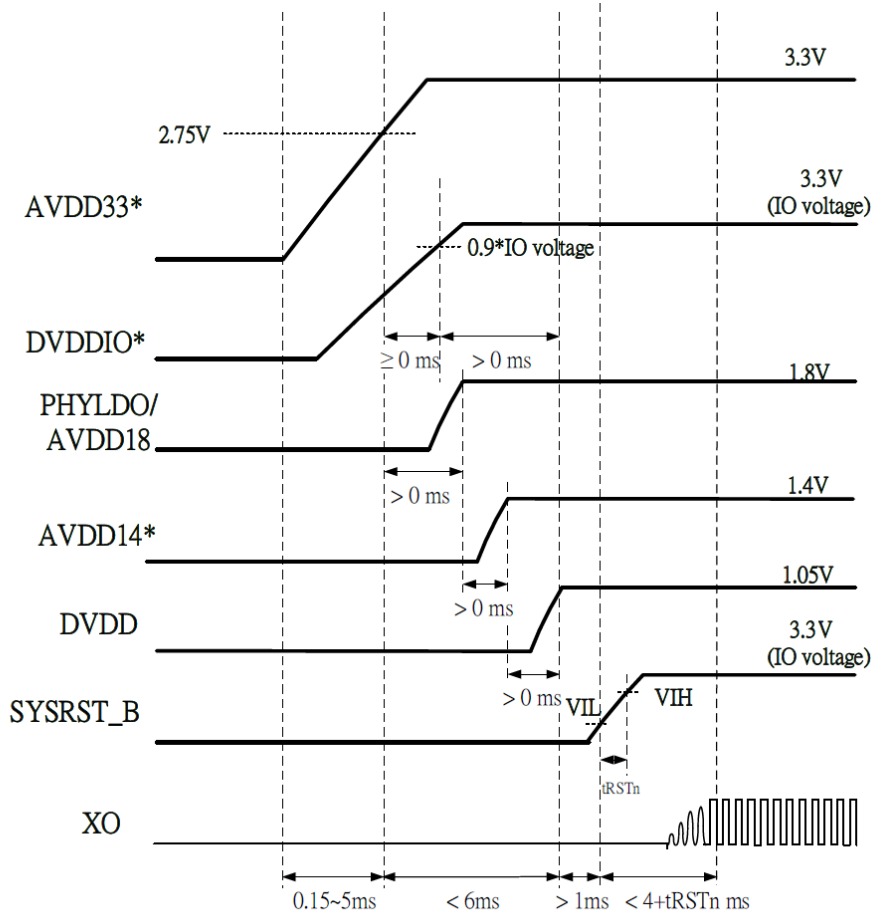

5.1 reset sequence

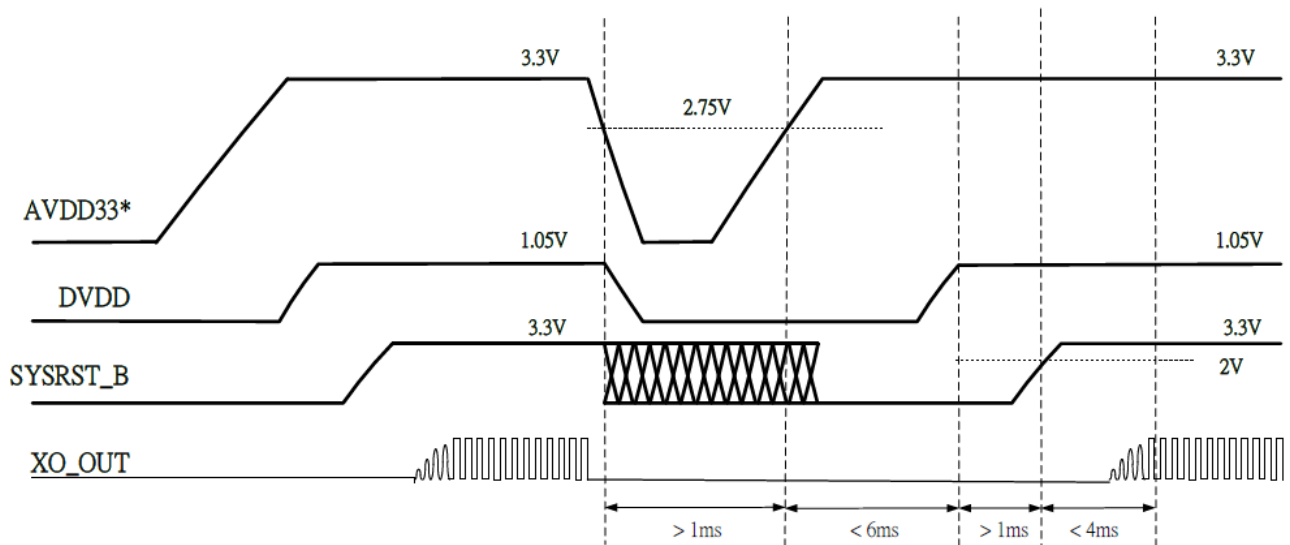

6. Software Requirements

The driver supports the following operating systems: Linux, Microsoft Windows XP, Vista and Win7.
Mfg. software tool is MT7663BUN_QA_Tool.

7. DC Characteristics

Symbol	Parameter	Min	Type	Max	Unit
DVDDIO	3.3V IO Voltage	2.97	3.3V	3.63	V
V_{IL}	Input Low Voltage	-0.3	-	$V_{DD33} * 0.25$	V
V_{IH}	Input High Voltage	$V_{DD33} * 0.625$	-	$V_{DD33} + 0.3$	V
V_{OL}	Output Low Voltage	-0.3	-	0.4	V
V_{OH}	Output High Voltage	$V_{DD33} - 0.4$	-	$V_{DD33} + 0.3$	V

8. Antenna matching

The 2th, 9th and 12th Pin connect to antenna, please refer to design demand

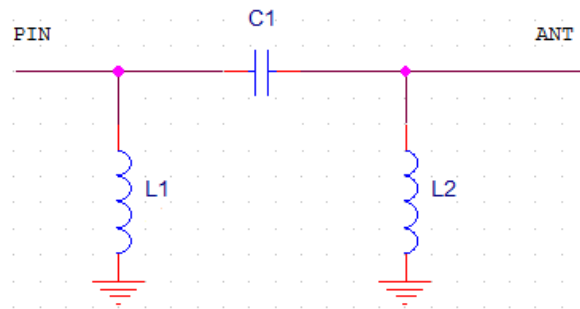

8.Packaging Information:

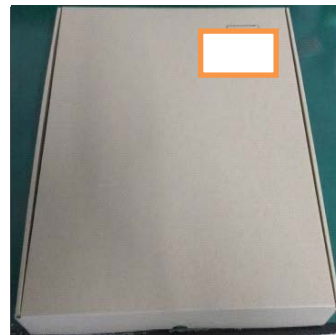
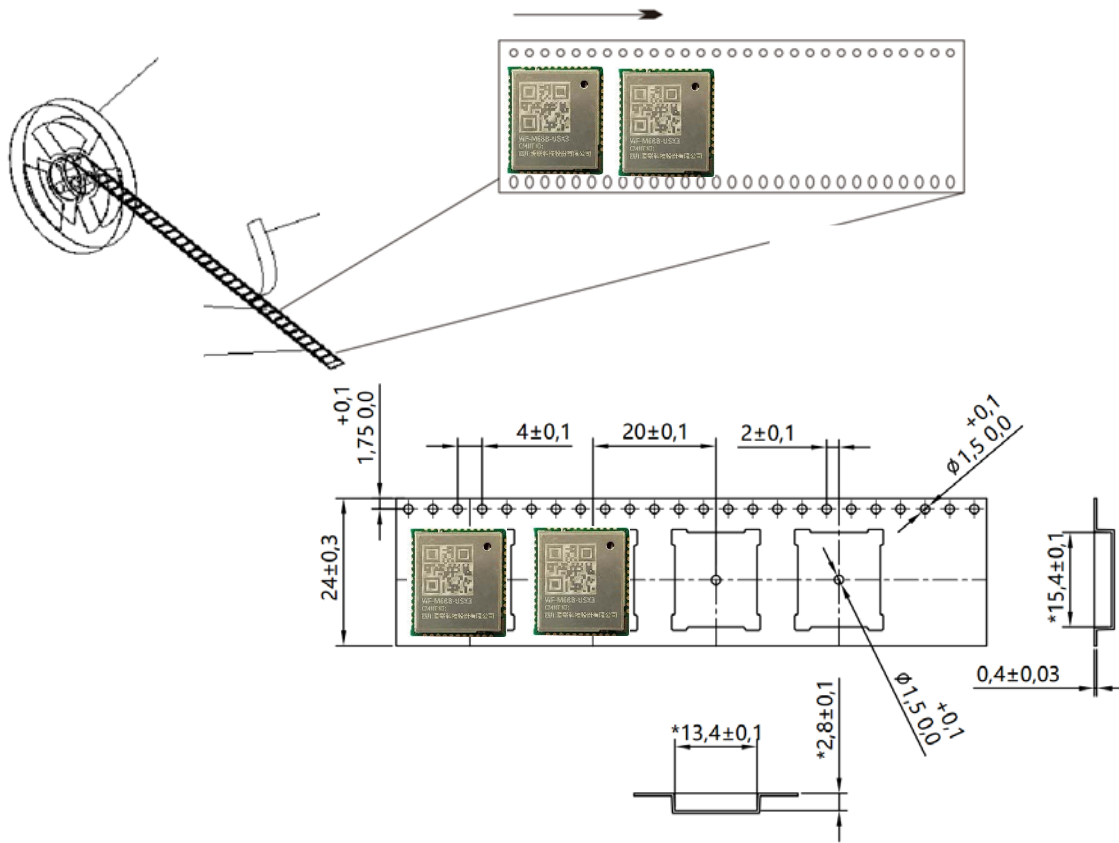

1. Product placement direction, label sticking position and packaging shall be carried out according to the schematic diagram;
2. Put 1000 pieces of products in each roll, 1 roll in each small box, 8 small boxes in total in the big box, 8000 pieces in total in quantity/box;
- 3, outer box size: 370mm*300mm*370mm, small box size: 360mm*360mm*37mm;
4. Two bags of 2G desiccant and one 6-color humidity card are placed in the vacuum bag;
5. Other unmentioned matters shall be carried out according to customer's packaging requirements.

9. Product Label&Label Location:

CE Radiation Exposure Statement

Herby, Sichuan AI-Link Technology Co., Ltd. Declares that this RF 2.4G&5G Wireless and BT Module , WF-M63B-USX2, WF-M63B-USX3 are in compliance with the essential requirements and other relevant provisions of Directive 2014/53/EU.

Operation Temperature: Use the WF-M63B-USX2, WF-M63B-USX3 in the environment with the temperature between -10°C and 70°C

Operation Frequency range:2.400 ~ 2.4835 GHz,5.150~5.350 GHz,5.470~5.725 GHz,5.725~5.850 GHz,5.850~5.925 GHz

RF Output Power: Max 20dBm

Manufacturer: Sichuan AI-Link Technology Co., Ltd.

Address: Anzhou, Industrial Park, Mianyang, Sichuan

Tel: +86-0816-2438701

Fax: +86-0816-2416943

E-mail: ai-link@ailinkiot.com

FCC warning:

This device complies with part 15 of the FCC Rules. Operation is subject to the following two conditions : (1) This device may not cause harmful interference, and (2) this device must accept any interference received, including interference that may cause undesired operation.

Any Changes or modifications not expressly approved by the party responsible for compliance could void the user's authority to operate the equipment.

Note: This equipment has been tested and found to comply with the limits for a Class B digital device, pursuant to part 15 of the FCC Rules. These limits are designed to provide reasonable protection against harmful interference in a residential installation. This equipment generates uses and can radiate radio frequency energy and, if not installed and used in accordance with the instructions, may cause harmful interference to radio communications. However, there is no guarantee that interference will not occur in a particular installation. If this equipment does cause harmful interference to radio or television reception, which can be determined by turning the equipment off and on, the user is encouraged to try to correct the interference by one or more of the following measures:

-Reorient or relocate the receiving antenna.

-Increase the separation between the equipment and receiver.

-Connect the equipment into an outlet on a circuit different from that to which the receiver is connected.

-Consult the dealer or an experienced radio/TV technician for help.

This equipment complies with FCC radiation exposure limits set forth for an uncontrolled environment.

This equipment should be installed and operated with minimum distance 20cm between the radiator & your body.

The separate approval is required for all other operating configurations, including portable configurations with respect to Part 2.1093 and different antenna configurations.

The OEM may operate only with the following antenna or antennas of the same type with maximum gain as shown:FPC antenna with 2 dBi linear far field gain

- RF I/O interface to the antenna connector on the Printed Circuit Board shall be accomplished via microstrip or stripline transmission line with characteristic impedance of 50 ohms +/- 10%. A custom coaxial pigtail may also be utilized to connect to the antenna in lieu of a connector.

- The connector on the OEM's Printed Circuit Board which interfaces to the antenna must be of a unique type to disable connection to a non-permissible antenna in compliance with FCC section 15.203.

- The minimum safe distance for people from the WF-M63B-USX2, WF-M63B-USX3 been determined by conservative calculation to be less than 20 cm for the allowable antenna types. The end product User's Guide must include the following statement in a prominent location: To comply with FCC's RF radiation exposure requirements, the antenna(s) used for this transmitter must be installed such that a minimum separation distance of 20 cm is maintained between the radiator (antenna) & user's/nearby people's body at all times and must not be co-located or operating in conjunction with any other antenna or transmitter.

Warning:

The module is limited to installation in mobile or fixed application. The OEM integrator is responsible for ensuring the end-user has no manual instruction to remove or install module; Modular approval allows installation in different end-use products by an original equipment manufacturer (OEM) with limited or no additional testing or equipment authorization for the transmitter function provided by the WF-M63B-USX2, WF-M63B-USX3.

Specifically: 1.No additional transmitter compliance testing is required if the module is operated with the antenna listed in the document below.2.No additional transmitter-compliance testing is required if the module is operated with the same general type of antenna (i.e. near-field segmented loop, circularly polarized patches) as those listed in this User's Guide and in the FCC filing for the WF-M63B-USX2, WF-M63B-USX3. Acceptable antennas must be of equal or less far field gain than the antenna previously authorized under the same FCC ID, and must have similar in band and out of band characteristics. In addition, the end product must comply with all applicable FCC equipment authorizations, regulations, requirements and equipment functions not associated with the WF-M63B-USX2, WF-M63B-USX3. For example, compliance must be demonstrated to regulations for other transmitter components within the host product, to requirements for unintentional radiators (Part 15B), and to additional authorization requirements for the non-transmitter functions.

The OEM applying the WF-M63B-USX2, WF-M63B-USX3 is required to include all FCC and/or IC statements and warnings detailed in the following sections to the end product labeling (where specified) and in the finished product manual.

The OEM must also strictly adhere to antenna and installation guidelines and MPE restrictions stated in this document. The finished product manual must contain the following statement: The host product shall use physical label stating "contains module FCC ID: 2AOKI-WFM63BUSX3" or "contains FCC ID: 2AOKI-WFM63BUSX3"

IC warning:

This device contains licence-exempt transmitter(s)/receiver(s) that comply with Innovation, Science and Economic Development Canada's licence-exempt RSS(s). Operation is subject to the following two conditions:

- 1.This device may not cause interference.
- 2.This device must accept any interference, including interference that may cause undesired operation of the device.

L'émetteur/récepteur exempt de licence contenu dans le présent appareil est conforme aux CNR d'Innovation, Sciences et Développement économique Canada applicables aux appareils radio exempts de licence. L'exploitation est autorisée aux deux conditions suivantes :

- (1)L'appareil ne doit pas produire de brouillage;
- (2)L'appareil doit accepter tout brouillage radioélectrique subi, même si le brouillage est susceptible d'en compromettre le fonctionnement.

This equipment complies with IC RSS-102 radiation exposure limits set forth for an uncontrolled environment. This equipment should be installed and operated with minimum distance 20cm between the radiator and your body.

Cet équipement est conforme aux limites d'exposition aux radiations IC CNR-102 établies pour un environnement non contrôlé.

Cet équipement doit être installé et utilisé avec une distance minimale de 20cm entre le radiateur et votre corps.

Please notice that if the IC identification number is not visible when the module is installed inside another device, then the outside of the device into which the module is installed must also display a label referring to the enclosed module. This exterior label can use wording such as the following: "Contains IC: **23460-WFM63BUSX3**" any similar wording that expresses the same meaning may be used.

L'étiquette d'homologation d'un module d'Innovation, Sciences et Développement économique Canada devra être posée sur le produit hôte à un endroit bien en vue, en tout temps. En l'absence d'étiquette, le produit hôte doit porter une étiquette sur laquelle figure le numéro d'homologation du module d'Innovation, Sciences et Développement économique Canada, précédé du mot « contient », ou d'une formulation similaire allant dans le même sens et qui va comme suit : Contient IC:

23460-WFM63BUSX3 est le numéro d'homologation du module.

- i. the device for operation in the band 5150–5250 MHz is only for indoor use to reduce the potential for harmful interference to co-channel mobile satellite systems;
 - ii. for devices with detachable antenna(s), the maximum antenna gain permitted for devices in the bands 5250-5350 MHz and 5470-5725 MHz shall be such that the equipment still complies with the e.i.r.p. limit;
 - iii. for devices with detachable antenna(s), the maximum antenna gain permitted for devices in the band 5725-5850 MHz shall be such that the equipment still complies with the e.i.r.p. limits as appropriate; and
- i. le dispositif utilisé dans la bande 5150-5250 MHz est réservé à une utilisation en intérieur afin de réduire le risque de brouillage préjudiciable aux systèmes mobiles par satellite dans le même canal;
 - ii. pour les dispositifs à antenne (s) détachable (s), le gain d'antenne maximal autorisé pour les dispositifs dans les bandes 5250-5350 MHz et 5470-5725 MHz doit être tel que l'équipement soit toujours conforme à la norme e.i.r.p. limite; pour les dispositifs à antenne (s) détachable (s), le gain d'antenne maximal autorisé pour les dispositifs de la bande 5725-5850 MHz doit être tel que l'équipement soit toujours conforme à la norme e.i.r.p. les limites, le cas échéant; et

Requirement per KDB996369 D03

1.1 List of applicable FCC rules

List the FCC rules that are applicable to the modular transmitter. These are the rules that specifically establish the bands of operation, the power, spurious emissions, and operating fundamental frequencies. DO NOT list compliance to unintentional-radiator rules (Part 15 Subpart B) since that is not a condition of a module grant that is extended to a host manufacturer. See also Section 2.10 below concerning the need to notify host manufacturers that further testing is required.³

Explanation: This module meets the requirements of FCC part 15C(15.247).

1.2 Summarize the specific operational use conditions

Describe use conditions that are applicable to the modular transmitter, including for example any limits on antennas, etc. For example, if point-to-point antennas are used that require reduction in power or compensation for cable loss, then this information must be in the instructions. If the use condition limitations extend to professional users, then instructions must state that this information also extends to the host manufacturer's instruction manual. In addition, certain information may also be needed, such as peak gain per frequency band and minimum gain, specifically for master devices in 5 GHz DFS bands.

Explanation: The EUT has a FPC Antenna, , and the antenna use a permanently attached antenna which is not replaceable.

1.3 Limited module procedures

If a modular transmitter is approved as a "limited module," then the module manufacturer is responsible for approving the host environment that the limited module is used with. The manufacturer of a limited module must describe, both in the filing and in the installation instructions, the alternative means that the limited module manufacturer uses to verify that the host meets the necessary requirements to satisfy the module limiting conditions.

A limited module manufacturer has the flexibility to define its alternative method to address the conditions that limit the initial approval, such as: shielding, minimum signaling amplitude, buffered modulation/data inputs, or power supply regulation. The alternative method could include that the limited module manufacturer reviews detailed test data or host designs prior to giving the host manufacturer approval.

This limited module procedure is also applicable for RF exposure evaluation when it is necessary to demonstrate compliance in a specific host. The module manufacturer must state how control of the product into which the modular transmitter will be installed will be maintained such that full compliance of the product is always ensured. For additional hosts other than the specific host originally granted with a limited module, a Class II permissive change is required on the module grant to register the additional host as a specific host also approved with the module.

Explanation: The module is not a limited module.

1.4 RF exposure considerations

It is essential for module grantees to clearly and explicitly state the RF exposure conditions that permit a host product manufacturer to use the module. Two types of instructions are required for RF exposure information: (1) to the host product manufacturer, to define the application conditions (mobile, portable – xx cm from a person's body); and (2) additional text needed for the host product manufacturer to provide to end users in their end-product manuals. If RF exposure statements and use conditions are not provided, then the host product manufacturer is required to take responsibility of the module through a change in FCC ID (new application).

Explanation: This module complies with FCC RF radiation exposure limits set forth for an uncontrolled environment, This equipment should be installed and operated with a minimum distance of 20 centimeters between the radiator and your body." This module is designed to comply with the FCC statement, FCC ID is: **2AOKI-WFM63BUSX3**

1.5 Antennas

A list of antennas included in the application for certification must be provided in the instructions. For modular transmitters approved as limited modules, all applicable professional installer instructions must be included as part of the information to the host product manufacturer. The antenna list shall also identify the antenna types (monopole, PIFA, dipole, etc. (note that for example an “omni-directional antenna” is not considered to be a specific “antenna type”)).

For situations where the host product manufacturer is responsible for an external connector, for example with an RF pin and antenna trace design, the integration instructions shall inform the installer that unique antenna connector must be used on the Part 15 authorized transmitters used in the host product. The module manufacturers shall provide a list of acceptable unique connectors.

Explanation: The EUT has a FPC Antenna, , and the antenna use a permanently attached antenna which is unique.

1.6 Label and compliance information

Grantees are responsible for the continued compliance of their modules to the FCC rules. This includes advising host product manufacturers that they need to provide a physical or e-label stating “Contains FCC ID” with their finished product. See Guidelines for Labeling and User Information for RF Devices – KDB Publication 784748.

Explanation:The host system using this module, should have label in a visible area indicated the following texts: "Contains FCC ID: **2AOKI-WFM63BUSX3**

1.7 Information on test modes and additional testing requirements5

Additional guidance for testing host products is given in KDB Publication 996369 D04 Module Integration Guide. Test modes should take into consideration different operational conditions for a stand-alone modular transmitter in a host, as well as for multiple simultaneously transmitting modules or other transmitters in a host product.

The grantee should provide information on how to configure test modes for host product evaluation for different operational conditions for a stand-alone modular transmitter in a host, versus with multiple, simultaneously transmitting modules or other transmitters in a host.

Grantees can increase the utility of their modular transmitters by providing special means, modes, or instructions that simulates or characterizes a connection by enabling a transmitter. This can greatly simplify a host manufacturer's determination that a module as installed in a host complies with FCC requirements.

Explanation: Topband can increase the utility of our modular transmitters by providing instructions that simulates or characterizes a connection by enabling a transmitter.

1.8 Additional testing, Part 15 Subpart B disclaimer

The grantee should include a statement that the modular transmitter is only FCC authorized for the specific rule parts (i.e., FCC transmitter rules) listed on the grant, and that the host product manufacturer is responsible for compliance to any other FCC rules that apply to the host not covered by the modular transmitter grant of certification. If the grantee markets their product as being Part 15 Subpart B compliant (when it also contains unintentional-radiator digital circuitry), then the grantee shall provide a notice stating that the final host product still requires Part 15 Subpart B compliance testing with the modular transmitter installed.

Explanation: The module without unintentional-radiator digital circuitry, so the module does not require an evaluation by FCC Part 15 Subpart B. The host should be evaluated by the FCC Subpart B.