

# 四川爱联

秘密级别： 公开  
生效时间： 2021年12月24日  
保密期限： 长期

## AL-7605B-WG-A

### 特性 Features:

- 接收制式 **Supported WLAN Standard**  
IEEE Std. 802.11a  
IEEE Std. 802.11b  
IEEE Std. 802.11g  
IEEE Std. 802.11n
- 芯片方案 **Chip Solution**  
MTK MT7605BU
- 结构大小 **Size**  
47.0mm x 30.0mm x 6.0mm



接口 Interface	安装方式 Assemble	频段 Band	天线 Antenna	供电 Power supply
USB	Screwing	2.4G/5G	One External Antenna One Internal Antenna	3.3V

## 四川爱联科技股份有限公司

Sichuan AI-Link Technology Co.,Ltd.

地址 Add: 四川省绵阳市安州工业园区

Anzhou,Industrial park,Mianyang,Sichuan

联系电话 TEL : +86-13881190925

电子邮件 Email : shengwu.chang@changhong.com

网址 : <http://www.aillinkiot.com>



## 客户确认反馈

## Feedback of customer's Confirmation

经确认，我方承认该规格书

We accept the specification after Confirmed

客户名称 Customer name	客户签字 Customer signature	确认日期 Confirmation Date

请签字后将此页与首页按以下地址回传我公司，谢谢！

Please feed back this paper and first paper after your signature by the address,thanks!

地址：四川省绵阳市安州工业园区

ADD: Anzhou,Industrial park,Mianyang,Sichuan

公司：四川爱联科技股份有限公司

Factory: Sichuan AI-Link Technology Co.,Ltd.

批准 Approved	审核 Checked	拟制 Designed	产品 Product	无线模块 WiFi Module
陈进	范西君	覃达开	型号 Model	AL-7605B-WG-A
			日期 Date	2021-12-24

### 更改记录 Record of Modification

版本 Version	更改日期 Date	主要更改内容 Main content of modification	确认 Confirm
V0.1	2021/12/24	首次发布 First release	覃达开

## 1. Introduction

AL-7605B-WG-A module design is based on MT7605 solution, The MT7605 is a highly integrated single chip which has built in a 2x2 dual-band wireless LAN radio. The Module is a highly integrated MAC/BBP and 2.4/5GHz PA/LNA single chip which supports a 300Mbps PHY rate. The Module is designed to support standard-based features in the areas of security, quality of service, and international regulations, giving end users the greatest performance anytime and in any circumstance. This documentation describes the engineering requirements specification.

### 1.1 RF module Overview

The general HW architecture for the module is shown in Figure 1. This WLAN Module design is based on MT7605. It is a highly integrated single-chip MIMO(Multiple In Multiple Out) Wireless LAN (WLAN) network interface controller complying with the 802.11 specification over USB interface. It combines a MAC, a 2T2R capable baseband, and RF in a single chip. An intelligent Wi-Fi coexistence algorithm is implemented to provide the best harmonized Wi-Fi performance.

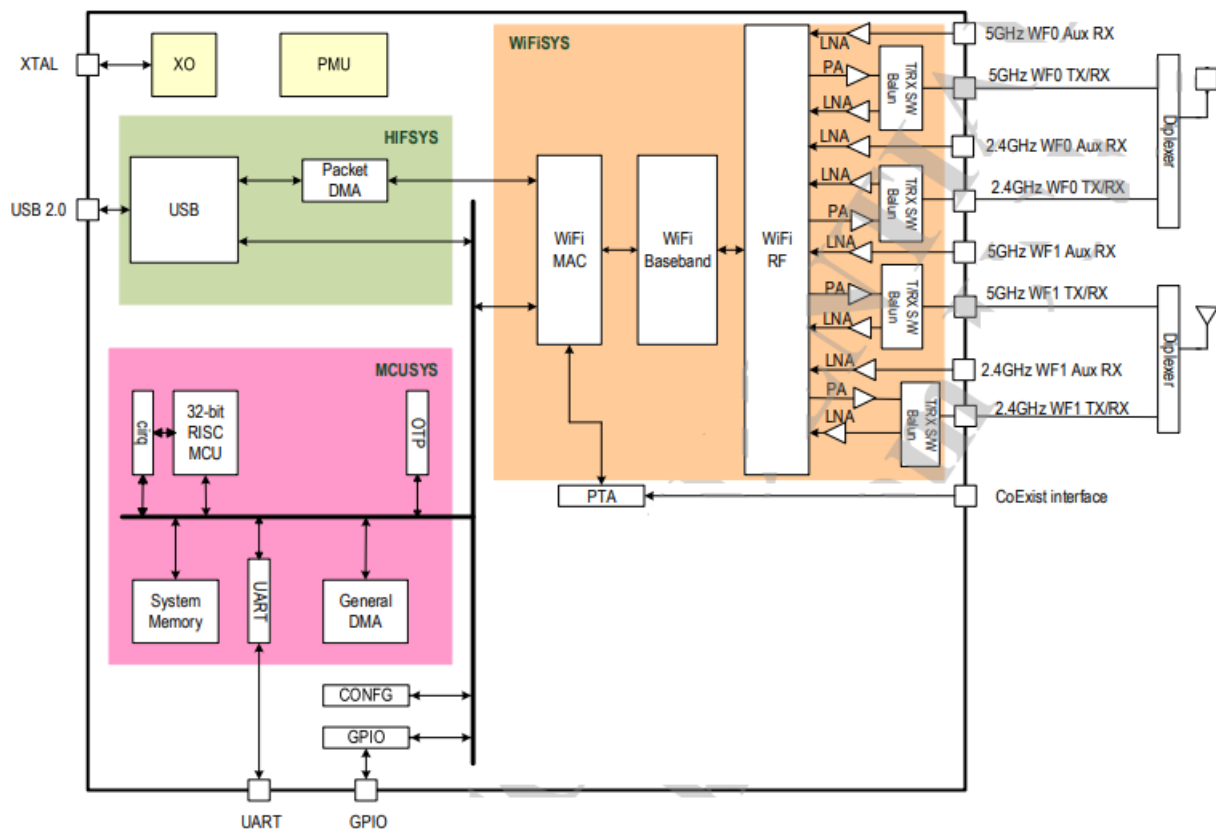

Figure 1 AL-7605B-WG-A Block Diagram

### 1.2 Specification reference

This specification is based on additional references listed below.

- \_ IEEE Std. 802.11a
- \_ IEEE Std. 802.11b
- \_ IEEE Std. 802.11g
- \_ IEEE Std. 802.11n

### 1.3 System Functions

Table1: General Specification as below:

Main Chipset	MT7605BU
Operating Frequency	2.4G/5G
WiFi Standard	802.11a/b/g/n (2x2)
Modulation	WIFI:11b: DBPSK, DQPSK, CCK for DSSS 11a/g: BPSK, QPSK, 16QAM, 64QAM for OFDM 11n: BPSK, QPSK, 16QAM, 64QAM for OFDM
Data rates	11b: 1, 2, 5.5 and 11Mbps 11a/g: 6, 9, 12, 18, 24, 36, 48 and 54 Mbps 11n: MCS0~15, up to 300Mbps
Form factor	10pins
Host Interface	USB 2.0
PCB Stack	4-layers design
Dimension	Typical, 30.0mm x47.0mm x 6.0mm
Antenna	One External Antennas, One Internal Antennas Design
Operation Temperature	0°C to +70°C
Storage Temperature	-40°C to +80°C
Operation Voltage	3.3V +/-10%
Power Consumption	1000mA Max

## 2. Mechanical Specification

### 2.1 Mechanical Outline Drawing

Typical Dimension (W x L ):30.0mmx 47.0mm x 6.0mm

General tolerance:  $\pm 0.3\text{mm}$

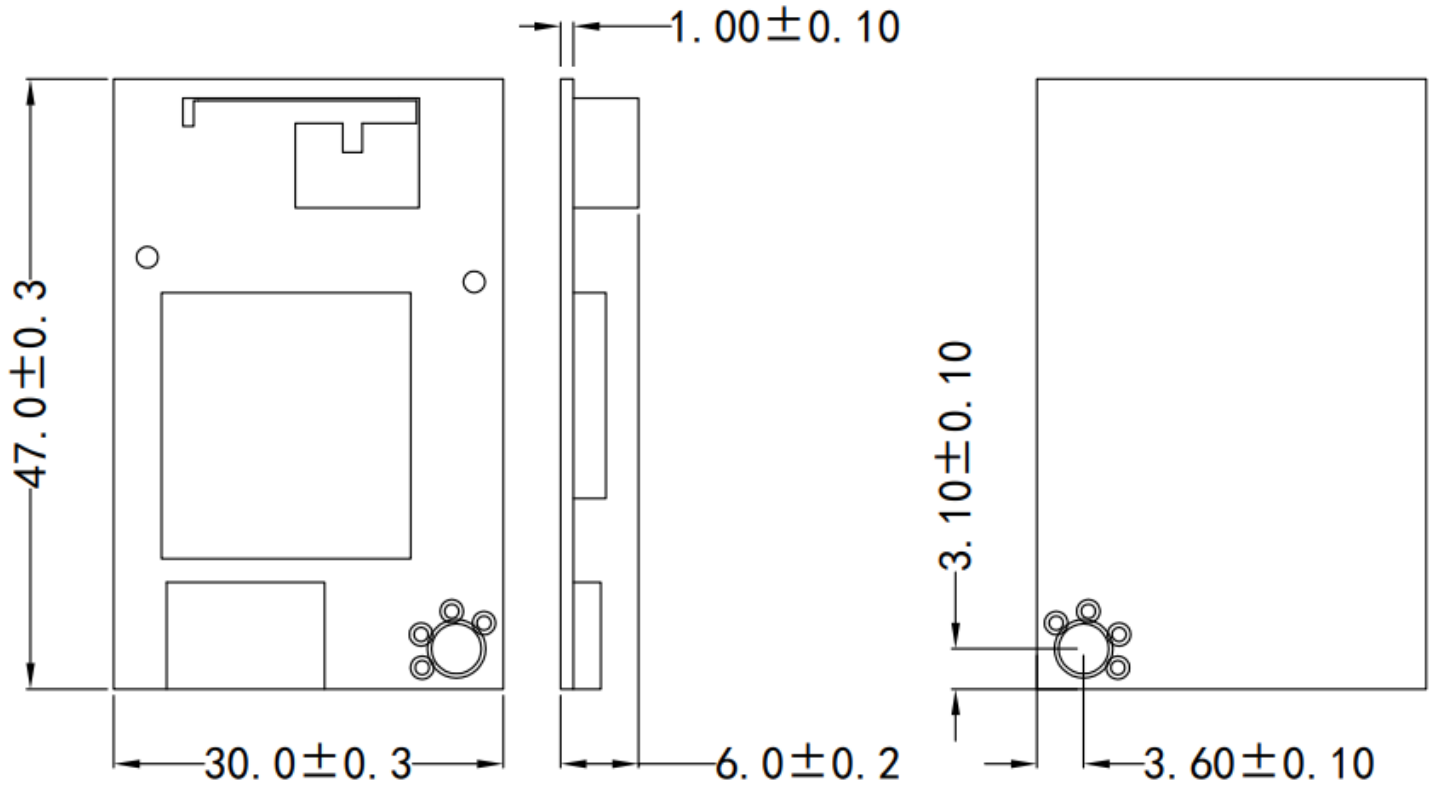

### 2.2 Pin define



Pin	Define	Description
1	PIN1	GND
2	PIN2	HSDP
3	PIN3	HSDM
4	PIN4	VIN
5	PIN5	VIN
6	PIN6	VIN
7	PIN7	WL_WAKE_HOST
8	PIN8	HOST_WAKE_WL
9	PIN9	RESET
10	PIN10	GND

### 2.3 Product Picture



**TOP VIEW**

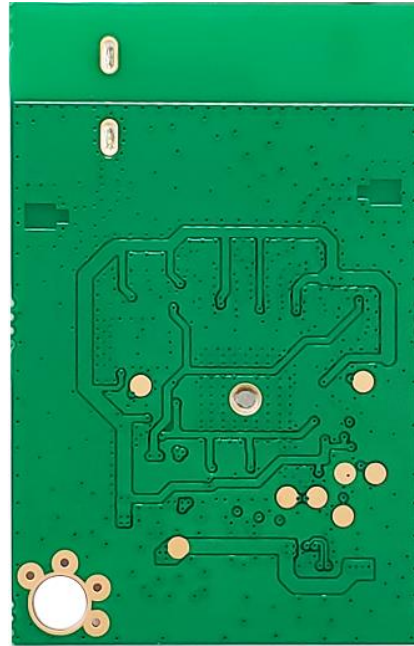

**BOTTOM VIEW**

### 3. Electrical Specification

This Specification is based-on conductive DVT testing result. The extreme condition include overall temperature (0°C,+25°C,+40°C) and overall voltage (3.0V,3.3V,3.6V).

#### 3.1 IEEE 802.11b Section:

Items	Contents				
Specification	IEEE802.11b				
Mode	DBPSK, DQPSK and CCK and DSSS				
Channel	CH1 to CH11				
Data rate	1, 2, 5.5, 11Mbps				
TX Characteristics	Min.	Typ.	Max.	Unit	Remark
1. Power Levels(Calibrated)					
1) 21.5dBm Target (For Each antenna port) @11Mbps	19.5	21.5	23.5	dBm	
2. Spectrum Mask @ Target Power					
1) fc +/-11MHz to +/-22MHz	-	-	-30	dBr	
2) fc > +/-22MHz	-	-	-50	dBr	
3. Constellation Error(EVM) @ Target Power					
1) 1Mbps	-	-	-10	dB	
2) 2Mbps	-	-	-10	dB	
3) 5.5Mbps	-	-	-10	dB	
4) 11Mbps	-	-20	-10	dB	
4. Frequency Error	-15	-	-15	ppm	
RX Characteristics	Min.	Typ.	Max.	Unit	
5. Minimum Input Level Sensitivity(each chain)					
1) 1Mbps (FER $\leq$ 8%)	-	-99	-88	dBm	
2) 11Mbps (FER $\leq$ 8%)	-	-90	-82	dBm	
6. Maximum Input Level (FER $\leq$ 8%)	-10	-	-	dBm	



## 3. 2 IEEE 802.11g/a Section:

Items	Contents					
Specification	IEEE802.11g & IEEE802.11a					
Mode	BPSK, QPSK, 16QAM, 64QAM and OFDM					
Channel	CH1 to CH11 @ 11g CH36,CH40,CH44,CH48 CH52,CH56,CH60,CH64,CH100,CH104,CH108,CH112,C H116,CH120,CH124,CH128,CH132,CH136,CH140CH149 ,CH153.CH157,CH161,CH165@ 11a					
Data rate	6, 9, 12, 18, 24, 36, 48, 54Mbps					
TX Characteristics		Min.	Typ.	Max.	Unit	Remark
1. Power Levels						
1) 18.5dBm Target (For Each antenna port) @ 11g 54Mbps		16.5	18.5	20.5	dBm	
2) 17.0dBm Target (For Each antenna port) @ 11a 54Mbps		15.0	17.0	19.0	dBm	
2. Spectrum Mask @ Target Power						
1) at fc +/-11MHz		-	-	-20	dBr	
2) at fc +/-20MHz		-	-	-28	dBr	
3) at fc > +/-30MHz		-	-	-40	dBr	
3. Constellation Error(EVM) @ Target Power						
1) 6Mbps		-	-	-5	dB	
2) 9Mbps		-	-	-8	dB	
3) 12Mbps		-	-	-10	dB	
4) 18Mbps		-	-	-13	dB	
5) 24Mbps		-	-	-16	dB	
6) 36Mbps		-	-	-19	dB	
7) 48Mbps		-	-	-22	dB	
8) 54Mbps		-	-	-25	dB	
4. Frequency Error						
1) IEEE802.11g		-15	-	-15	ppm	
2) IEEE802.11a		-15	-	-15	ppm	
RX Characteristics		Min.	Typ.	Max.	Unit	
5. Minimum Input Level Sensitivity(each chain)						
1) 6Mbps (PER $\leq$ 10%)		-	-96	-86	dBm	
2) 54Mbps (PER $\leq$ 10%)		-	-77	-73	dBm	
6. Maximum Input Level (PER $\leq$ 10%)						
1) IEEE802.11g		-20	-	-	dBm	
2) IEEE802.11a		-30	-	-	dBm	

## 3.3 IEEE 802.11n HT20 Section:

Items	Contents				
Specification	IEEE802.11n HT20 @ 2.4G IEEE802.11n HT20 @ 5G				
Mode	BPSK, QPSK, 16QAM, 64QAM and OFDM				
Channel	CH1 to CH11 @ 2.4G CH36,CH40,CH44,CH48 CH52,CH56,CH60,CH64,CH100,CH104,CH108,CH112, CH116,CH120,CH124,CH128,CH132,CH136,CH140, CH149,CH153.CH157,CH161,CH165@ 5G				
Data rate (MCS index)	MCS0/1/2/3/4/5/6/7/8/9/10/11/12/13/14/15				
TX Characteristics	Min.	Typ.	Max.	Unit	Remark
1. Power Levels					
1) 18.0dBm Target (For Each antenna port) @ 2.4G MCS7	16.0	18.0	20.0	dBm	
2) 16.0dBm Target (For Each antenna port) @ 5G MCS7	14.0	16.0	18.0	dBm	
2. Spectrum Mask @ Target Power					
1) at fc +/-11MHz	-	-	-20	dBr	
2) at fc +/-20MHz	-	-	-28	dBr	
3) at fc > +/-30MHz	-	-	-45	dBr	
3. Constellation Error(EVM) @ Target Power					
1) MCS0	-	-	-5	dB	
2) MCS1	-	-	-10	dB	
3) MCS2	-	-	-13	dB	
4) MCS3	-	-	-16	dB	
5) MCS4	-	-	-19	dB	
6) MCS5	-	-	-22	dB	
7) MCS6	-	-	-25	dB	
8) MCS7	-	-	-27	dB	
4. Frequency Error					
1) IEEE802.11n HT20 @ 2.4G	-15	-	-15	ppm	
2) IEEE802.11n HT20 @ 5G	-15	-	-15	ppm	
RX Characteristics	Min.	Typ.	Max.	Unit	
5. Minimum Input Level Sensitivity(each chain)					
1) MCS0 (PER $\leq$ 10%)	-	-95	-86	dBm	
2) MCS7 (PER $\leq$ 10%)	-	-75	-70	dBm	
6. Maximum Input Level (PER $\leq$ 10%)					
1) IEEE802.11n HT20 @ 2.4G	-20	-	-	dBm	
2) IEEE802.11n HT20 @ 5G	-30	-	-	dBm	

**3.4 IEEE 802.11n HT40 Section:**

Items	Contents				
Specification	IEEE802.11n HT40 @ 2.4G IEEE802.11n HT40 @ 5G				
Mode	BPSK, QPSK, 16QAM, 64QAM and OFDM				
Channel	CH3 to CH9 @ 2.4G CH38,CH46,CH54,CH62,CH102,CH110,CH118,CH126, CH134,CH151,CH159 @ 5G				
Data rate (MCS index)	MCS0/1/2/3/4/5/6/7/8/9/10/11/12/13/14/15				
TX Characteristics	Min.	Typ.	Max.	Unit	Remark
1. Power Levels (Calibrated)					
1) 17.5dBm Target (For Each antenna port) @ 2.4G MCS7	15.5	17.5	19.5	dBm	
2) 16.0dBm Target (For Each antenna port) @ 5G MCS7	14.0	16.0	180	dBm	
2. Spectrum Mask @ Target Power					
1) at fc +/-21MHz	-	-	-20	dBr	
2) at fc +/-40MHz	-	-	-28	dBr	
3) at fc > +/-60MHz	-	-	-45	dBr	
3. Constellation Error(EVM) @ Target Power					
1) MCS0	-	-	-5	dB	
2) MCS1	-	-	-10	dB	
3) MCS2	-	-	-13	dB	
4) MCS3	-	-	-16	dB	
5) MCS4	-	-	-19	dB	
6) MCS5	-	-	-22	dB	
7) MCS6	-	-	-25	dB	
8) MCS7	-	-	-27	dB	
4. Frequency Error					
1) IEEE802.11n HT40 @ 2.4G	-15	-	-15	ppm	
2) IEEE802.11n HT40 @ 5G	-15	-	-15	ppm	
RX Characteristics	Min.	Typ.	Max.	Unit	
5. Minimum Input Level Sensitivity(each chain)					
1) MCS0 (PER $\leq$ 10%)	-	-92	-83	dBm	
2) MCS7 (PER $\leq$ 10%)	-	-70	-66	dBm	
6. Maximum Input Level(PER $\leq$ 10%)					
1) IEEE802.11n HT40 @ 2.4G	-20	-	-	dBm	
2) IEEE802.11n HT40 @ 5G	-30	-	-	dBm	

**4. Software Requirements**

The driver supports the following operating systems: Linux, Microsoft Windows XP, Vista and Win7.  
Mfg. software tool is QAtool

## 5. Antenna specification

NO.	Type	Antenna Project Code	Gain	Part No.
1	External PIFA Antenna	PIFA Antenna	3.46 dBi(@2.4 ~ 2.5 GHz) 3.37 dBi(@5.15 ~ 5.85 GHz)	RFMTA3009**IMLB401
2	External PIFA Antenna	PIFA Antenna	1.72 dBi(@2.4 ~ 2.5 GHz) 2.57 dBi(@5.15 ~ 5.85 GHz)	SLK-T3010-L-**-B
3	Onboard PIFA Antenna	PIFA Antenna	3.79 dBi(@2.4 ~ 2.5 GHz) 3.68 dBi(@5.15 ~ 5.85 GHz)	RFMTA170900NNLB00 3

## 6. Product label, label location

As shown in the figure below:

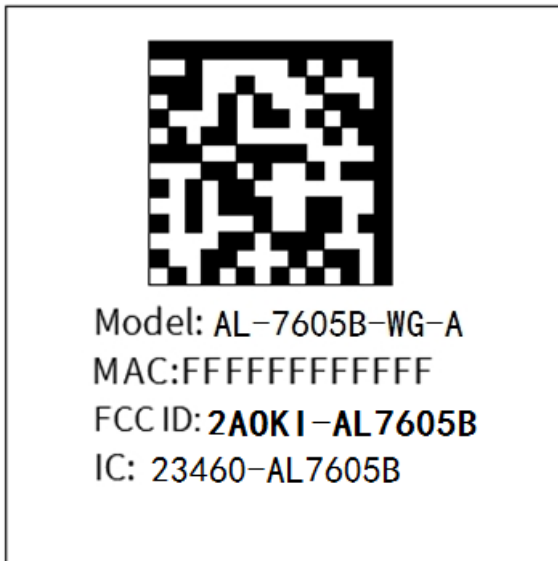

## 7. Conditions of use

Please keep the antenna away from metal and horn interference sources.

## 8.Key component List

序号	关键件名称	型号	规格/材料	生产者	备注
1	集成电路	MT7605BU		MTK	
2	PCB	JUI7.820.0101 Series	FR-4,4LAY	科翔 顺络 英创 连立 坤	
3	晶体振荡器	SMD3225-40M	40M	Hosonic 加高 泰晶 佳利 华科 顺络	
4	DPX		2.4G@5G		

## 9.Order

订单料号	规格	备注
AL-7605B-WG-A	2.4G,5G;802.11n;ffc connector;	
WF-M605B-UWD1	2.4G,5G;802.11n;ffc connectpr;	
WF-M605B-UWD2	2.4G,5G;802.11n;	

## 10、Waste disposal

The disposal of our products shall comply with local/superior region/national/international applicable laws and regulations.

## 11. Packaging Information:

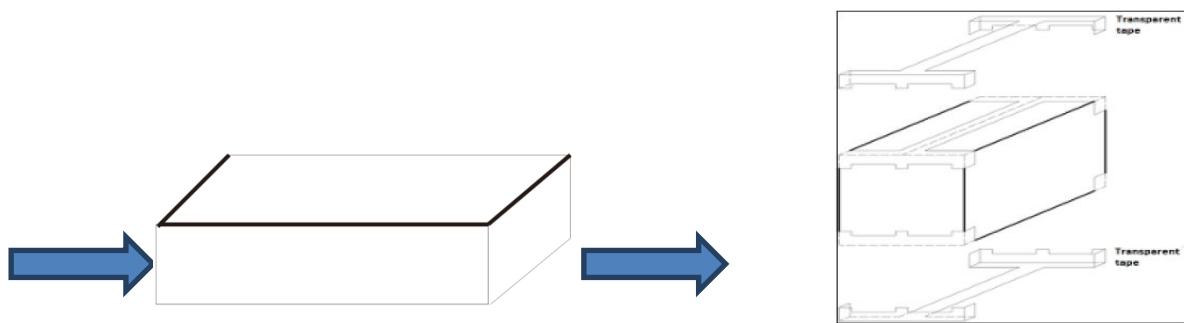
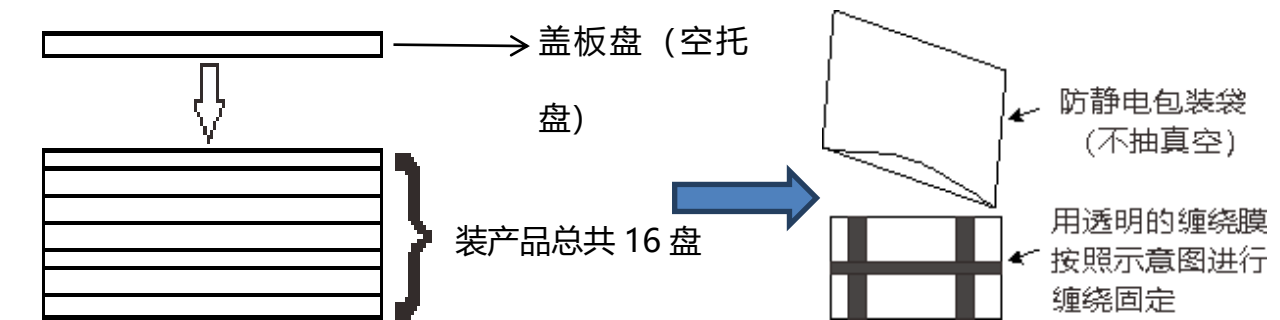
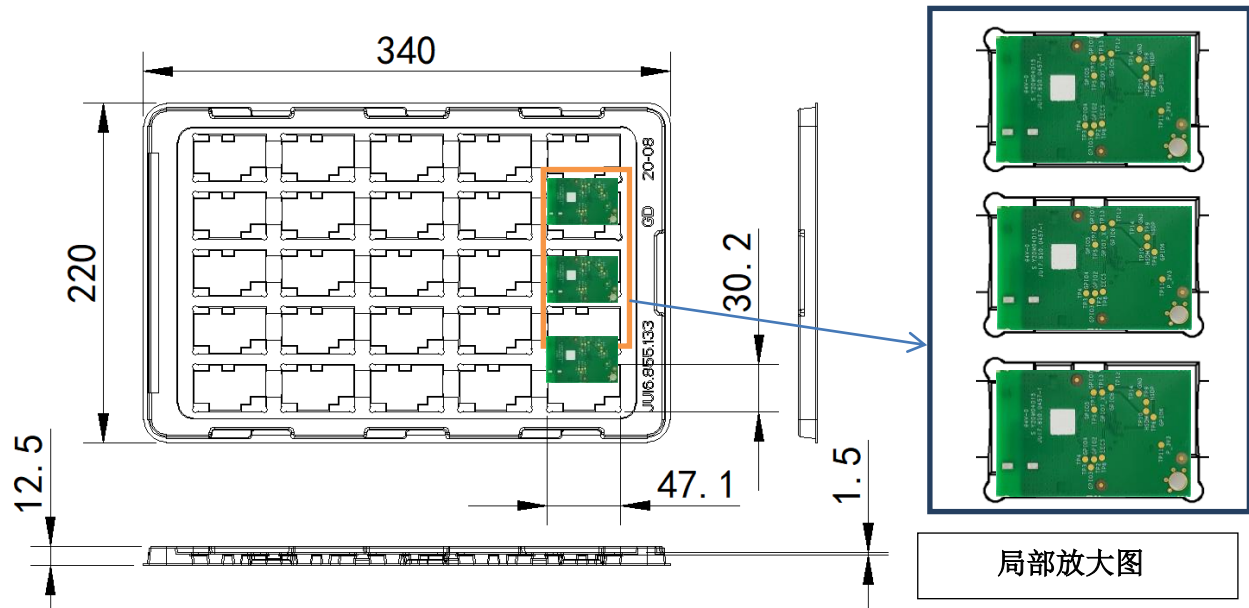

(包装盒封胶形式如上图)

("工"字型封胶)

- 1、产品放置方向、标签粘贴位置、包装按示意图进行;
- 2、包装盒内放入2包2g干燥剂和一张湿度卡;
- 3、产品数量每层25只, 上层放一个空托盘, 每箱装4盒共计1600pcs, 每盒400pcs产品;
- 4、外箱尺寸: 499mm\*394mm\*298mm;
- 5、其它未尽事宜按照客户包装要求执行。

## 12. FCC Statement

### FCC regulatory compliance statement

This device complies with Part 15 of the FCC Rules. Operation is subject to the following two conditions: (1) this device may not cause harmful interference, and (2) this device must accept any interference received, including interference that may cause undesired operation.

Warning: changes or modifications not expressly approved by the party responsible for compliance could void the user's authority to operate the equipment.

This Module complies with FCC radiation exposure limits set forth for an uncontrolled environment. This equipment should be installed and operated with a minimum distance of 20cm between the radiator and your body. This transmitter must not be co-located or operating in conjunction with any other antenna or transmitter.

#### Labelling Instruction for Host Product Integrator

Please notice that if the FCC identification number is not visible when the module is installed inside another device, then the outside of the device into which the module is installed must also display a label referring to the enclosed module. This exterior label can use wording such as the following: "Contains FCC ID: **2AOKI-AL7605B**" any similar wording that expresses the same meaning may be used.

#### Installation Notice to Host Product Manufacturer

The OEM integrator is responsible for ensuring that the end-user has no manual instruction to remove or install module. The module is limited to installation in mobile application, a separate approval is required for all other operating configurations, including portable configurations with respect to §2.1093 and difference antenna configurations.

#### Antenna Change Notice to Host manufacturer

If you desire to increase antenna gain and either change antenna type or use same antenna type certified, a Class II permissive change application is required to be filed by us, or you (host manufacturer) can take responsibility through the change in FCC ID (new application) procedure followed by a Class II permissive change application.

#### FCC other Parts, Part 15B Compliance Requirements for Host product manufacturer

This modular transmitter is only FCC authorized for the specific rule parts listed on our grant, host product manufacturer is responsible for compliance to any other FCC rules that apply to the host not covered by the modular transmitter grant of certification.

Host manufacturer in any case shall ensure host product which is installed and operating with the module is in compliant with Part 15B requirements.

*Note: This equipment has been tested and found to comply with the limits for a Class B digital device, pursuant to part 15 of the FCC Rules. These limits are designed to provide reasonable protection against harmful interference in a residential installation. This equipment generates, uses and can radiate radio frequency energy and, if not installed and used in accordance with the instructions, may cause harmful interference to radio communications. However, there is no guarantee that interference will not occur in a particular installation. If this equipment does cause harmful interference to radio or television reception, which can be determined by turning the equipment off and on, the user is encouraged to try to correct the interference by one or more of the following measures:*

- Reorient or relocate the receiving antenna.*
- Increase the separation between the equipment and receiver.*
- Connect the equipment into an outlet on a circuit different from that to which the receiver is connected.*
- Consult the dealer or an experienced radio/TV technician for help.*

## 13.ISED Regulatory Compliance

This device contains licence-exempt transmitter(s)/receiver(s) that comply with Innovation, Science and Economic Development Canada's licence-exempt RSS(s). Operation is subject to the following two conditions: (1) This device may not cause interference. (2) This device must accept any interference, including interference that may cause undesired operation of the device.

L'émetteur/récepteur exempt de licence contenu dans le présent appareil est conforme aux CNR d'Innovation, Sciences et Développement économique Canada applicables aux appareils radio exempts de licence. L'exploitation est autorisée aux deux conditions suivantes : (1) L'appareil ne doit pas produire de brouillage; (2) L'appareil doit accepter tout brouillage radioélectrique subi, même si le brouillage est susceptible d'en compromettre le fonctionnement.

This equipment complies with IC RSS-102 radiation exposure limits set forth for an uncontrolled environment. This equipment should be installed and operated with minimum distance 20cm between the radiator and your body.

Cet équipement est conforme aux limites d'exposition aux radiations IC CNR-102 établies pour un environnement non contrôlé. Cet équipement doit être installé et utilisé avec une distance minimale de 20cm entre le radiateur et votre corps.

Please notice that if the IC identification number is not visible when the module is installed inside another device, then the outside of the device into which the module is installed must also display a label referring to the enclosed module. This exterior label can use wording such as the following: "Contains IC: **23460-AL7605B**" any similar wording that expresses the same meaning may be used.

L'étiquette d'homologation d'un module d'Innovation, Sciences et Développement économique Canada devra être posée sur le produit hôte à un endroit bien en vue, en tout temps. En l'absence d'étiquette, le produit hôte doit porter une étiquette sur laquelle figure le numéro d'homologation du module d'Innovation, Sciences et Développement économique Canada, précédé du mot « contient », ou d'une formulation similaire allant dans le même sens et qui va comme suit : Contient IC: **23460-AL7605B** est le numéro d'homologation du module.

- i. the device for operation in the band 5150–5250 MHz is only for indoor use to reduce the potential for harmful interference to co-channel mobile satellite systems;
  - ii. for devices with detachable antenna(s), the maximum antenna gain permitted for devices in the bands 5250-5350 MHz and 5470-5725 MHz shall be such that the equipment still complies with the e.i.r.p. limit;
  - iii. for devices with detachable antenna(s), the maximum antenna gain permitted for devices in the band 5725-5850 MHz shall be such that the equipment still complies with the e.i.r.p. limits as appropriate; and
- i. le dispositif utilisé dans la bande 5150-5250 MHz est réservé à une utilisation en intérieur afin de réduire le risque de brouillage préjudiciable aux systèmes mobiles par satellite dans le même canal;
  - ii. pour les dispositifs à antenne (s) détachable (s), le gain d'antenne maximal autorisé pour les dispositifs dans les bandes 5250-5350 MHz et 5470-5725 MHz doit être tel que l'équipement soit toujours conforme à la norme e.i.r.p. limite;
  - iii. pour les dispositifs à antenne (s) détachable (s), le gain d'antenne maximal autorisé pour les dispositifs de la bande 5725-5850 MHz doit être tel que l'équipement soit toujours conforme à la norme e.i.r.p. les limites, le cas échéant; et