

# FCC Test Report

Client Name : Anker Innovations Limited  
Address : Room 1318-19, Hollywood Plaza, 610 Nathan Road,  
Mongkok, Kowloon, Hong Kong  
Product Name : Doorbell Chime USB Dongle for HomeBase2  
Date : May 15, 2020



**Shenzhen Anbotek Compliance Laboratory Limited**

# Contents

- 1. General Information.....4
  - 1.1. Client Information.....4
  - 1.2. Description of Device (EUT).....4
  - 1.3. Auxiliary Equipment Used During Test.....4
  - 1.4. Description of Test Modes.....5
  - 1.5. List of channels.....5
  - 1.6. Description Of Test Setup.....6
  - 1.7. Test Equipment List.....7
  - 1.8. Measurement Uncertainty.....8
  - 1.9. Description of Test Facility.....8
- 2. Summary of Test Results.....9
- 3. Conducted Emission Test.....10
  - 3.1. Test Standard and Limit.....10
  - 3.2. Test Setup.....10
  - 3.3. Test Procedure.....10
  - 3.4. Test Data.....10
- 4. Radiation Spurious Emission and Band Edge.....13
  - 4.1. Test Standard and Limit.....13
  - 4.2. Test Setup.....14
  - 4.3. Test Procedure.....15
  - 4.4. Test Data.....15
- 5. 20DB Occupy Bandwidth Test.....21
  - 5.1. Test Standard and Limit.....21
  - 5.2. Test Setup.....21
  - 5.3. Test Procedure.....21
  - 5.4. Test Data.....21
- 6. Dwell Time Test.....23
  - 6.1. Test Standard and Limit.....23
  - 6.2. Test Setup.....23
  - 6.3. Test Procedure.....23
  - 6.4. Test Data.....23
- 7. Antenna Requirement.....25
  - 7.1. Test Standard and Requirement.....25
  - 7.2. Antenna Connected Construction.....25

# TEST REPORT

Applicant : Anker Innovations Limited  
Manufacturer : Anker Innovations Limited  
Product Name : Doorbell Chime USB Dongle for HomeBase2  
Model No. : T8741  
Trade Mark : eufy SECURITY  
Rating(s) : Input: DC 5V, 1A (from USB)

Test Standard(s) : **FCC Part15 Subpart C 2018, Section 15.231**  
Test Method(s) : **ANSI C63.10: 2013**

The device described above is tested by Shenzhen Anbotek Compliance Laboratory Limited to determine the maximum emission levels emanating from the device and the severe levels of the device can endure and its performance criterion. The measurement results are contained in this test report and Shenzhen Anbotek Compliance Laboratory Limited is assumed full of responsibility for the accuracy and completeness of these measurements. Also, this report shows that the EUT (Equipment Under Test) is technically compliant with the FCC Part 15 Subpart C requirements.

This report applies to above tested sample only and shall not be reproduced in part without written approval of Shenzhen Anbotek Compliance Laboratory Limited.

Date of Receipt : Apr. 16, 2020  
Date of Test : Apr. 16~30, 2020

Prepared By :   
\_\_\_\_\_  
(Engineer / Dolly Mo)

Reviewer :   
\_\_\_\_\_  
(Supervisor / Bibo Zhang)

Approved & Authorized Signer :   
\_\_\_\_\_  
(Manager / Tom Chen)



# 1. General Information

## 1.1. Client Information

Applicant	:	Anker Innovations Limited
Address	:	Room 1318-19, Hollywood Plaza, 610 Nathan Road, Mongkok, Kowloon, Hong Kong
Manufacturer	:	Anker Innovations Limited
Address	:	Room 1318-19, Hollywood Plaza, 610 Nathan Road, Mongkok, Kowloon, Hong Kong

## 1.2. Description of Device (EUT)

Product Name	:	Doorbell Chime USB Dongle for HomeBase2	
Model No.	:	T8741	
Trade Mark	:	eufy SECURITY	
Test Power Supply	:	AC 120V, 60Hz for HomeBase 2	
Product Description	:	Operation Frequency:	433.92MHz
		Number of Channel:	1 Channels
		Modulation Type:	GFSK
		Antenna Type:	Spring Antenna
		Antenna Gain(Peak):	0 dBi
<b>Remark:</b> 1) For a more detailed features description, please refer to the manufacturer's specifications or the User's Manual.			

## 1.3. Auxiliary Equipment Used During Test

adapter	:	Model: ASSA67A-120200 Input: AC 100-240V 50/60Hz 0.8A Output: DC 12V, 2A
HomeBase2	:	Model: T8010 Input: DC 12V, 2A USB Output: DC 5V, 2A

**1.4. Description of Test Modes**

To investigate the maximum EMI emission characteristics generates from EUT, the test system was pre-scanning tested base on the consideration of following EUT operation mode or test configuration mode which possible have effect on EMI emission level. Each of these EUT operation mode(s) or test configuration mode(s) mentioned above was evaluated respectively.

Pretest Mode	Description
Mode 1	TX Mode

For Radiated Emission	
Final Test Mode	Description
Mode 1	TX Mode

Note: During the test, the EUT was keeping continuous transmission.

**1.5. List of channels**

Channel	Freq. (MHz)	Note (Modulation Type)
01	433.92	GFSK

**1.6. Description Of Test Setup**

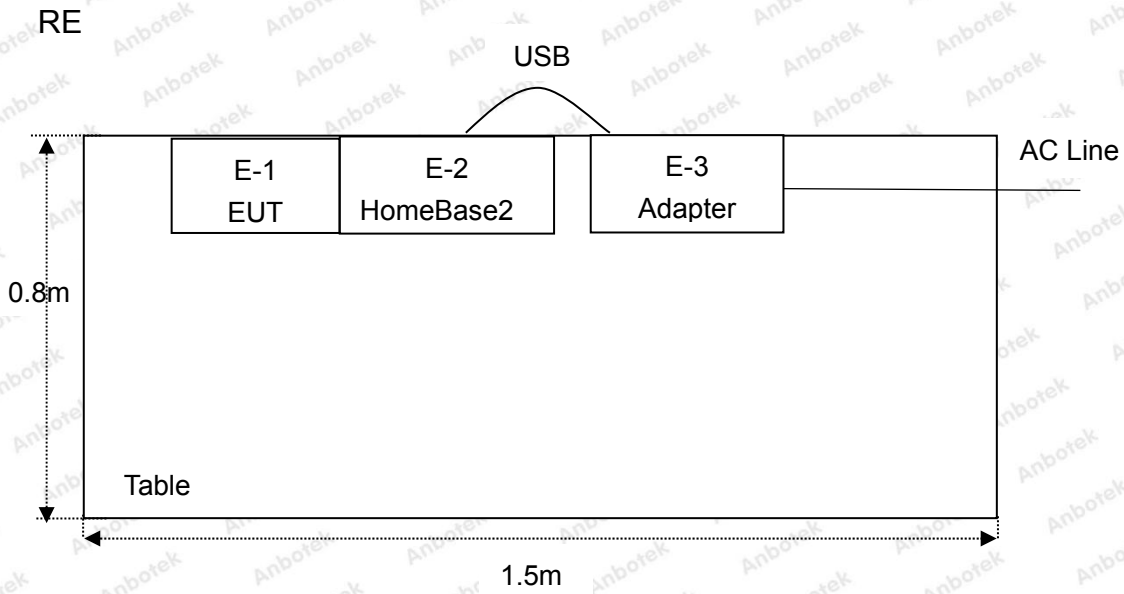
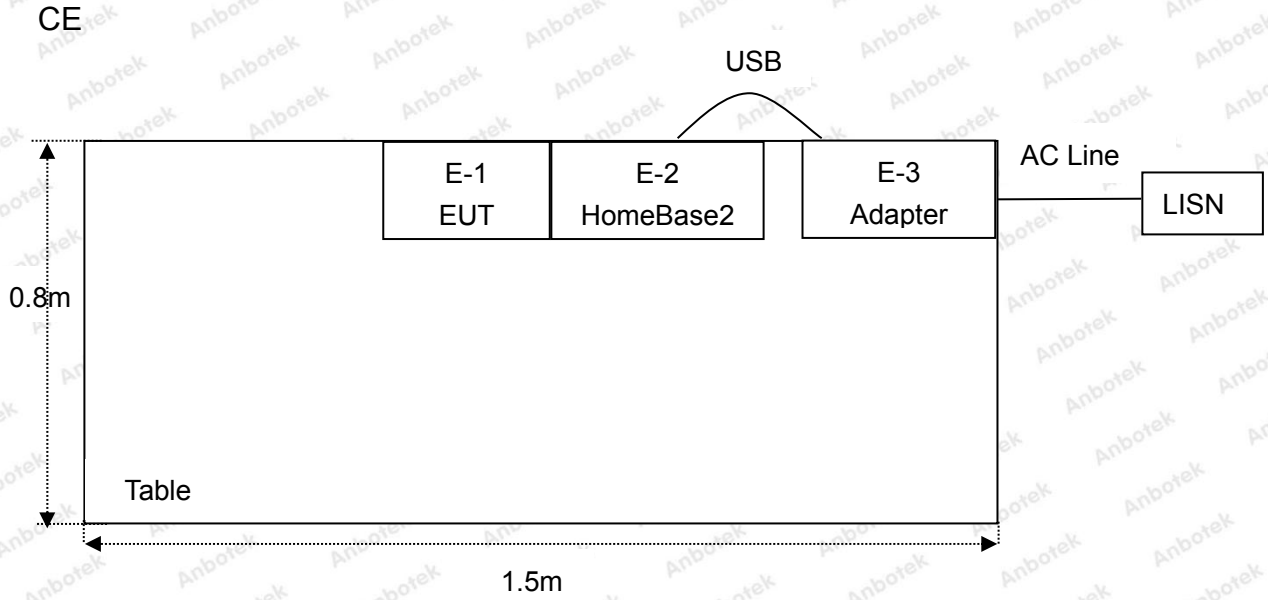



**1.7. Test Equipment List**

Item	Equipment	Manufacturer	Model No.	Serial No.	Last Cal.	Cal. Interval
1.	L.I.S.N. Artificial Mains Network	Rohde & Schwarz	ENV216	100055	Nov. 04, 2019	1 Year
2.	EMI Test Receiver	Rohde & Schwarz	ESPI3	101604	Nov. 04, 2019	1 Year
3.	RF Switching Unit	Compliance Direction	RSU-M2	38303	Nov. 04, 2019	1 Year
4.	MAX Spectrum Analysis	Agilent	N9020A	MY51170037	Nov. 04, 2019	1 Year
5.	Preamplifier	SKET Electronic	BK1G18G30 D	KD17503	Nov. 04, 2019	1 Year
6.	Double Ridged Horn Antenna	Instruments corporation	GTH-0118	351600	Nov. 01, 2019	1 Year
7.	Bilog Broadband Antenna	Schwarzbeck	VULB9163	VULB 9163-289	Nov. 01, 2019	1 Year
8.	Loop Antenna	Schwarzbeck	FMZB1519B	00053	Nov. 01, 2019	1 Year
9.	Horn Antenna	A-INFO	LB-180400-K F	J211060628	Nov. 01, 2019	1 Year
10.	Pre-amplifier	SONOMA	310N	186860	Nov. 04, 2019	1 Year
11.	EMI Test Software EZ-EMC	SHURPLE	N/A	N/A	N/A	N/A
12.	RF Test Control System	YIHENG	YH3000	2017430	Nov. 04, 2019	1 Year
13.	Power Sensor	DAER	RPR3006W	15I00041SN045	Nov. 04, 2019	1 Year
14.	Power Sensor	DAER	RPR3006W	15I00041SN046	Nov. 04, 2019	1 Year
15.	MXA Spectrum Analysis	Agilent	N9020A	MY51170037	Nov. 04, 2019	1 Year
16.	MXG RF Vector Signal Generator	Agilent	N5182A	MY48180656	Nov. 04, 2019	1 Year
17.	Signal Generator	Agilent	E4421B	MY41000743	Nov. 04, 2019	1 Year
18.	DC Power Supply	LW	TPR-6420D	374470	Nov. 04, 2019	1 Year
19.	Constant Temperature Humidity Chamber	ZHONGJIAN	ZJ-KHWS80 B	N/A	Nov. 04, 2019	1 Year

**1.8. Measurement Uncertainty**

Radiation Uncertainty	:	Ur = 3.9 dB (Horizontal)
		Ur = 3.8 dB (Vertical)
Conduction Uncertainty	:	Uc = 3.4 dB

**1.9. Description of Test Facility**

The test facility is recognized, certified, or accredited by the following organizations:

**FCC-Registration No.: 184111**

Shenzhen Anbotek Compliance Laboratory Limited, EMC Laboratory has been registered and fully described in a report filed with the (FCC) Federal Communications Commission. The acceptance letter from the FCC is maintained in our files. Registration No. 184111, September 27, 2019.

**ISED-Registration No.: 8058A**

Shenzhen Anbotek Compliance Laboratory Limited, EMC Laboratory has been registered and fully described in a report filed with the (ISED) Innovation, Science and Economic Development Canada. The acceptance letter from the ISED is maintained in our files. Registration 8058A, March 07, 2019.

**Test Location**

Shenzhen Anbotek Compliance Laboratory Limited.

1/F, Building D, Sogood Science and Technology Park, Sanwei community, Hangcheng Street, Bao'an District, Shenzhen, Guangdong, China.518102



## 2. Summary of Test Results

Standard Section	Test Item	Result
15.203	Antenna Requirement	PASS
15.207	Conducted Emission	PASS
15.205/15.209/15.231(b)	Spurious Emission	PASS
15.231(c)	20dB Occupied Bandwidth	PASS
15.231(a)	Dwell time	PASS
<b>Remark:</b> "N/A" is an abbreviation for Not Applicable.		

## 3. Conducted Emission Test

### 3.1. Test Standard and Limit

Test Standard	FCC Part15 Section 15.207		
Test Limit	Frequency	Maximum RF Line Voltage (dBuV)	
		Quasi-peak Level	Average Level
	150kHz~500kHz	66 ~ 56 *	56 ~ 46 *
	500kHz~5MHz	56	46
5MHz~30MHz	60	50	

**Remark:** (1) \*Decreasing linearly with logarithm of the frequency.  
 (2) The lower limit shall apply at the transition frequency.

### 3.2. Test Setup

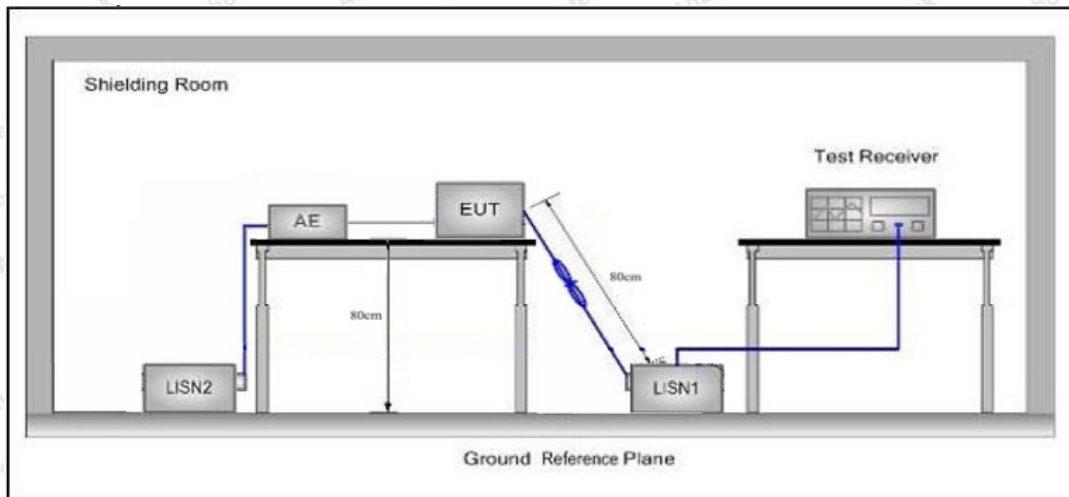

### 3.3. Test Procedure

The EUT system is connected to the power mains through a line impedance stabilization network (L.I.S.N.). This provides a 50ohm coupling impedance for the EUT system. Please refer the block diagram of the test setup and photographs. Both sides of AC line are checked to find out the maximum conducted emission. In order to find the maximum emission levels, the relative positions of equipment and all of the interface cables shall be changed according to FCC ANSI C63.10-2013 on Conducted Emission Measurement.

The bandwidth of test receiver (ESCI) set at 9kHz.

The frequency range from 150kHz to 30MHz is checked.

### 3.4. Test Data

Please to see the following pages.

**Conducted Emission Test Data**

Test Site: 1# Shielded Room  
 Operating Condition: Mode 1  
 Test Specification: AC 120V, 60Hz for HomeBase 2  
 Comment: Live Line  
 Tem.: 24.6°C Hum.: 57%

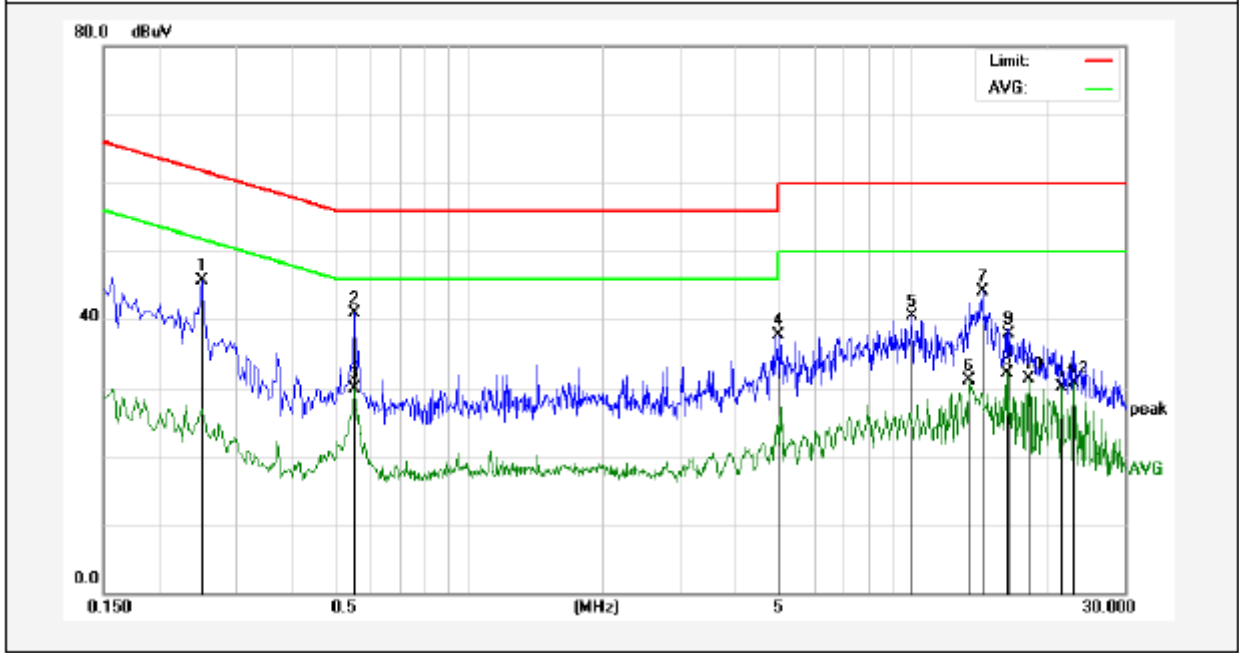

No.	Freq. (MHz)	Reading (dBuV)	Factor (dB)	Result (dBuV)	Limit (dBuV)	Over Limit (dB)	Detector	Remark
1	0.2500	25.91	19.89	45.80	61.75	-15.95	QP	
2	0.5540	20.92	20.00	40.92	56.00	-15.08	QP	
3	0.5540	9.90	20.00	29.90	46.00	-16.10	AVG	
4	4.9899	17.46	20.21	37.67	56.00	-18.33	QP	
5	9.9379	20.13	20.34	40.47	60.00	-19.53	QP	
6	13.3580	10.82	20.29	31.11	50.00	-18.89	AVG	
7	14.3340	23.88	20.27	44.15	60.00	-15.85	QP	
8	16.2300	11.78	20.28	32.06	50.00	-17.94	AVG	
9	16.4700	17.57	20.28	37.85	60.00	-22.15	QP	
10	18.3060	10.91	20.31	31.22	50.00	-18.78	AVG	
11	21.6620	9.76	20.32	30.08	50.00	-19.92	AVG	
12	23.1299	10.32	20.30	30.62	50.00	-19.38	AVG	



**Conducted Emission Test Data**

Test Site: 1# Shielded Room  
 Operating Condition: Mode 1  
 Test Specification: AC 120V, 60Hz for HomeBase 2  
 Comment: Neutral Line  
 Tem.: 24.6°C Hum.: 57%

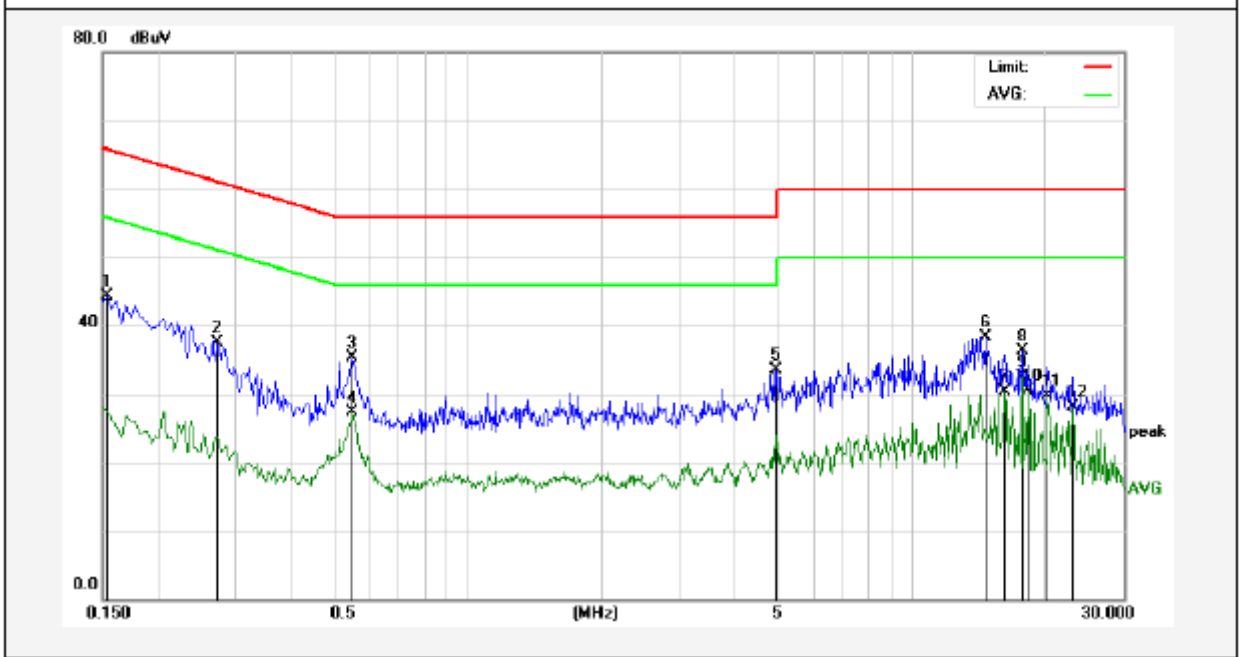

No.	Freq. (MHz)	Reading (dBuV)	Factor (dB)	Result (dBuV)	Limit (dBuV)	Over Limit (dB)	Detector	Remark
1	0.1539	24.43	19.90	44.33	65.78	-21.45	QP	
2	0.2740	17.54	19.89	37.43	60.99	-23.56	QP	
3	0.5500	15.36	19.99	35.35	56.00	-20.65	QP	
4	0.5500	7.40	19.99	27.39	46.00	-18.61	AVG	
5	4.9300	13.25	20.20	33.45	56.00	-22.55	QP	
6	14.6380	18.10	20.27	38.37	60.00	-21.63	QP	
7	16.1660	10.02	20.28	30.30	50.00	-19.70	AVG	
8	17.6940	16.09	20.30	36.39	60.00	-23.61	QP	
9	17.6940	12.23	20.30	32.53	50.00	-17.47	AVG	
10	18.3060	10.12	20.31	30.43	50.00	-19.57	AVG	
11	20.2580	9.46	20.34	29.80	50.00	-20.20	AVG	
12	23.1259	7.82	20.30	28.12	50.00	-21.88	AVG	

## 4. Radiation Spurious Emission and Band Edge

### 4.1. Test Standard and Limit

Test Standard	FCC Part15 C Section 15.209, 15.205 and 15.231(b)				
Test Limit	Frequency (MHz)	Field strength (microvolt/meter)	Limit (dBuV/m)	Remark	Measurement distance (m)
	0.009MHz~0.490MHz	2400/F(kHz)	-	-	300
	0.490MHz-1.705MHz	24000/F(kHz)	-	-	30
	1.705MHz-30MHz	30	-	-	30
	30MHz~88MHz	100	40.0	Quasi-peak	3
	88MHz~216MHz	150	43.5	Quasi-peak	3
	216MHz~960MHz	200	46.0	Quasi-peak	3
	960MHz~1000MHz	500	54.0	Quasi-peak	3
	Above 1000MHz	500	54.0	Average	3
-		74.0	Peak	3	

**Remark:**  
 (1)The lower limit shall apply at the transition frequency.  
 (2) 15.35(b), Unless otherwise specified, the limit on peak radio frequency emissions is 20dB above the maximum permitted average emission limit applicable to the equipment under test. This peak limit applies to the total peak emission level radiated by the device.

the formulas for calculating the maximum permitted fundamental field strengths are as follows:  
 for the band 260-470 MHz,  $\mu\text{V/m}$  at 3 meters =  $41.6667(F) - 7083.3333$ .

The maximum permitted unwanted emission level is 20 dB below the maximum permitted fundamental level

$$\text{Emission Level (dBuV/m)} = 20 \log \text{Emission Level}(\mu\text{V/m})$$

The field strength of emission limits have been calculated in below table:

Fundamental Frequency (MHz)	Field Strength of Fundamental (dBuV/m)@3m
433.92	80.82 (AVG)
433.92	100.82 (Peak)

**4.2. Test Setup**

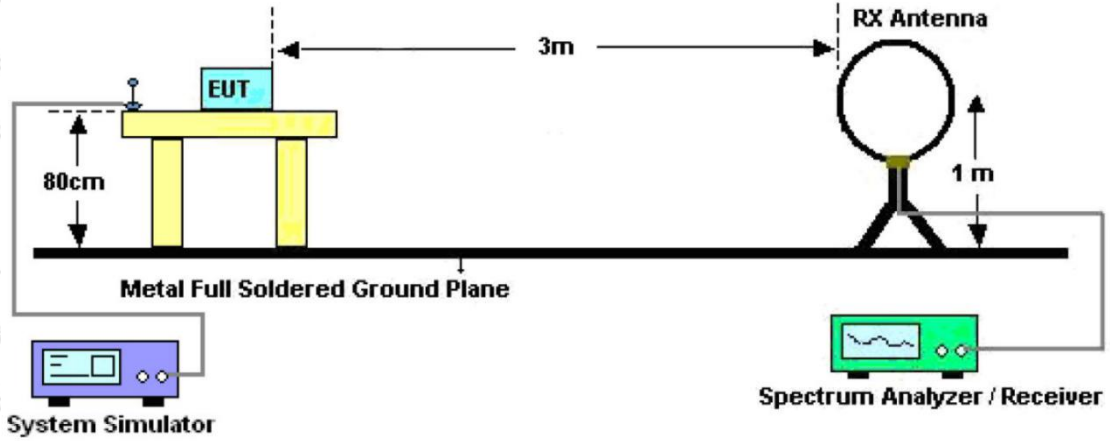

Figure 1. Below 30MHz

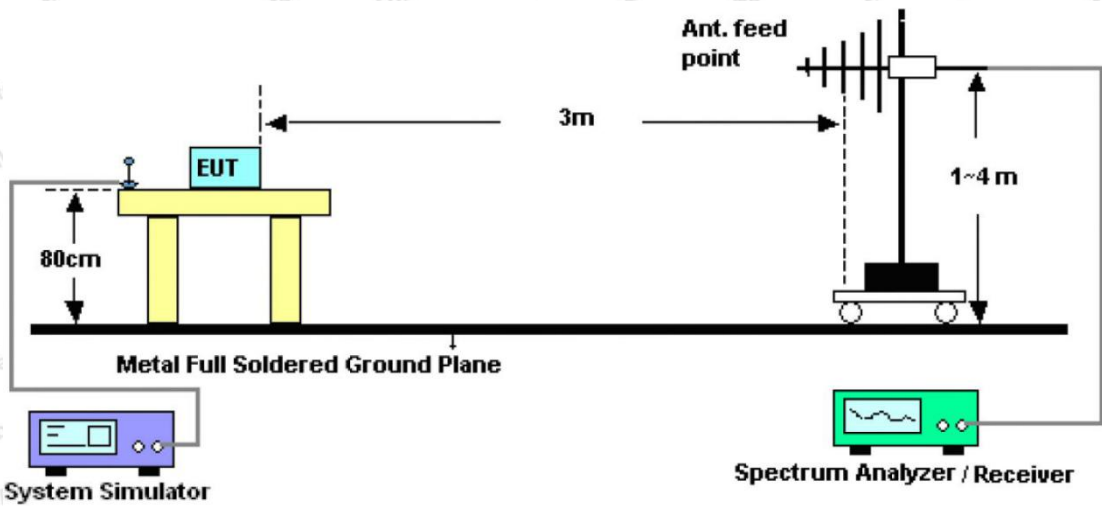

Figure 2. 30MHz to 1GHz

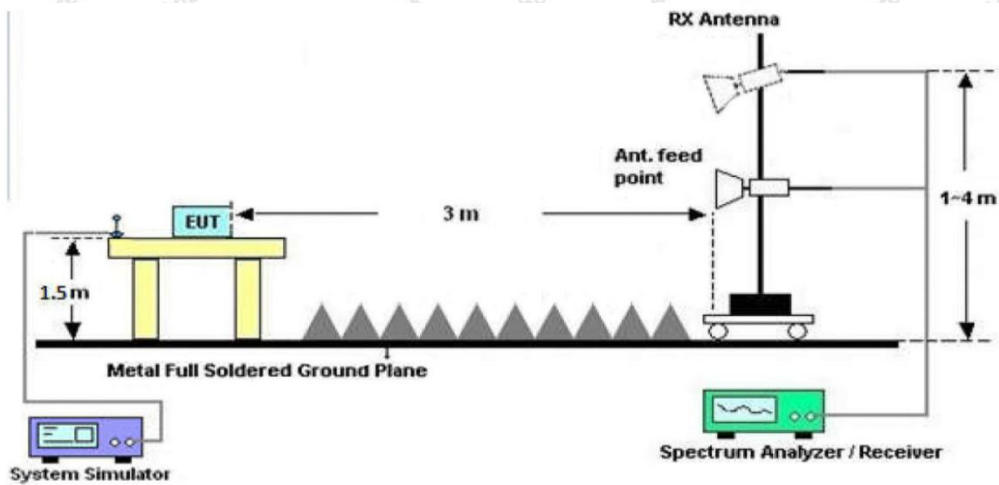

Figure 3. Above 1 GHz



### 4.3. Test Procedure

For below 1GHz: The EUT is placed on a turntable, which is 0.8m above the ground plane.

For above 1GHz: The EUT is placed on a turntable, which is 1.5m above the ground plane.

The turn table can rotate 360 degrees to determine the position of the maximum emission level. The EUT is set 3 meters away from the receiving antenna which is mounted on a antenna tower. The antenna can be moved up and down from 1 to 4 meters to find out the maximum emission level. Rotated the EUT through three orthogonal axes to determine the maximum emissions, both horizontal and vertical polarization of the antenna are set on test. The EUT is tested in 9\*6\*6 Chamber. The device is evaluated in xyz orientation.

For 9kHz to 150kHz, Set the spectrum analyzer as:

RBW = 200Hz, VBW =1kHz, Detector= Quasi-Peak, Trace mode= Max hold, Sweep- auto couple.

For 150kHz to 30MHz, Set the spectrum analyzer as:

RBW = 9KHz, VBW =30kHz, Detector= Quasi-Peak, Trace mode= Max hold, Sweep- auto couple.

For 30MHz to 1000MHz, Set the spectrum analyzer as:

RBW = 100kHz, VBW =300kHz, Detector= Quasi-Peak, Trace mode= Max hold, Sweep- auto couple.

For above 1GHz, Set the spectrum analyzer as:

RBW =1MHz, VBW =1MHz, Detector= Peak, Trace mode= Max hold, Sweep- auto couple.

RBW =1MHz, VBW =10Hz, Detector= Average, Trace mode= Max hold, Sweep- auto couple.

### 4.4. Test Data

#### PASS

During the test, Pre-scan all kind of the place mode (X-axis, Y-axis, Z-axis), and found the X-axis is the worst case.

The test results of 9kHz-30MHz and above 18000MHz are attenuated more than 20dB below the permissible limits, so the results don't record in the report.



**Test Results (Fundamental 433.92MHz)**

Frequency	Antenna	Reading	Cable Loss	Ant Factor	Amplifier	Duty cycle Factor	Results	Limits	Det.
(MHz)	Pol.	(dBuV/m)	(dB)	(dB)	(dB)	(dB)	(dBuV/m)	(dBuV/m)	Mode
433.92	H	94.74	1.52	12.64	31.45	-	77.45	100.82	PK
433.92	H	94.74	1.52	12.64	31.45	-8.75	68.70	80.82	AV
433.92	V	97.71	1.52	12.64	31.45	-	80.42	100.82	PK
433.92	V	97.71	1.52	12.64	31.45	-8.75	71.67	80.82	AV

**Remark:**

1. Result = Reading + Cable Loss +Ant Factor –Amplifier + Duty cycle Factor

2. Pulse Desensitization Correction Factor

Pulse Width (PW)= 0.232ms

2/PW=2/0.232=8.62kHz

RBW(1000kHz)> 2/PW (8.62kHz)

Therefore PDCF is not needed.

3. Duty Cycle Factor

Calculate Formula:

AV=PEAK +Duty Cycle Factor

Duty Cycle Factor=20log(Duty Cycle)

Duty Cycle= on time/ period

**Test Data:**

T on time=0.646ms\*10+0.232ms\*14=9.708 ms

T period=71.5ms-44.9ms=26.6ms

Duty Cycle=36.5%

Duty Cycle Factor =20log(Duty Cycle)=-8.75



T on time slot-1

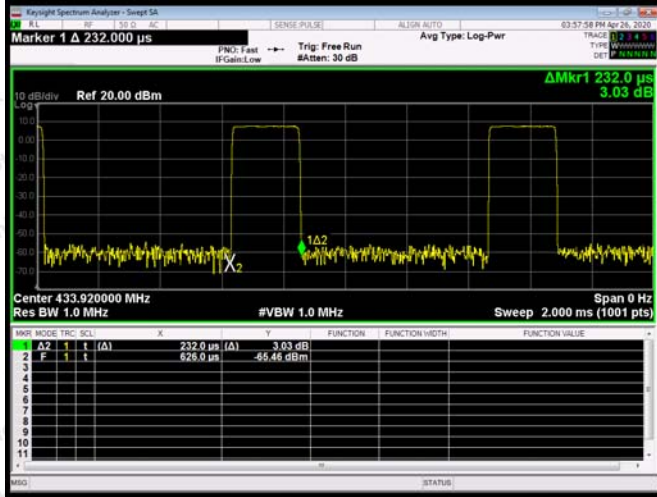

T on time slot-2

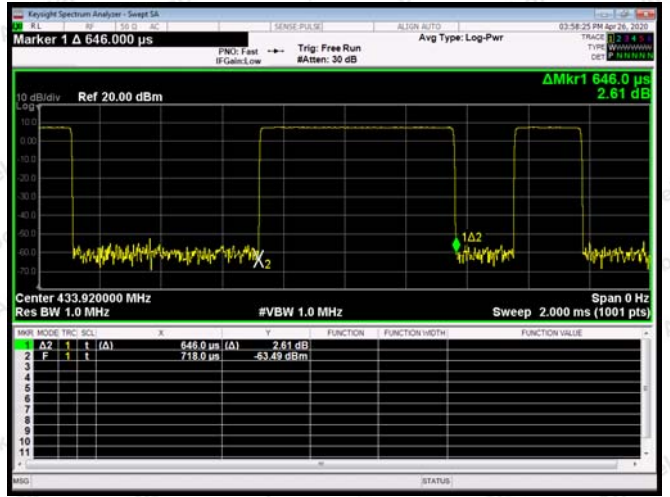

T period

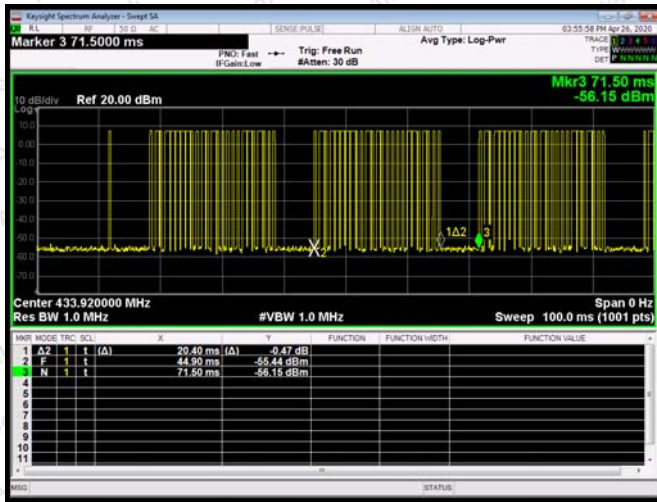



**Test Results (Harmonics Emissions)**

Frequency	Antenna	Reading	Cable Loss	Ant Factor	Amplifier	Duty cycle Factor	Results	Limits	Det
(MHz)	Pol.	(dBuV/m)	(dB)	(dB)	(dB)	(dB)	(dBuV/m)	(dBuV/m)	Mode
867.84	H	74.53	1.92	12.71	31.72	-	57.44	80.82	PK
867.84	H	74.53	1.92	12.71	31.72	-8.75	48.69	60.82	AV
867.84	V	76.60	1.92	12.71	31.72	-	59.51	80.82	PK
867.84	V	76.60	1.92	12.71	31.72	-8.75	50.76	60.82	AV
1301.76	H	63.34	2.38	21.43	32.45	-	54.70	74	PK
1301.76	H	63.34	2.38	21.43	32.45	-8.75	45.95	54	AV
1301.76	V	65.30	2.38	18.56	32.45	-	53.79	74	PK
1301.76	V	65.30	2.38	18.56	32.45	-8.75	45.04	54	AV

Remark :

1. Result = Reading + Cable Loss +Ant Factor –Amplifier + Duty cycle Factor

2. Pulse Desensitization Correction Factor

Pulse Width (PW)= 0.232ms

$2/PW=2/0.232=8.62\text{kHz}$

$RBW(1000\text{kHz}) > 2/PW (8.62\text{kHz})$

Therefore PDCF is not needed.

3. Duty Cycle Factor=-8.75

**Test Results (30~1000MHz)**

Job No.: 18220WC00037401

Temp.(°C)/Hum.(%RH): 22.6°C/56%RH

Standard: FCC PART 15C

Power Source: AC 120V, 60Hz for HomeBase 2

Test Mode: TX Mode

Polarization: Horizontal

Note:



No.	Freq. (MHz)	Reading (dBuV)	Factor (dB/m)	Result (dBuV/m)	Limit (dBuV/m)	Over Limit (dB)	Detector	Height (cm)	degree (deg)	Remark
1	39.5756	39.04	-16.28	22.76	40.00	-17.24	QP	100	126	
2	81.2116	47.65	-22.47	25.18	40.00	-14.82	QP	100	358	
3	147.9214	49.31	-22.15	27.16	43.50	-16.34	QP	100	146	
4	250.3009	45.78	-20.66	25.12	46.00	-20.88	QP	100	28	
5	590.9737	43.35	-9.73	33.62	46.00	-12.38	QP	100	340	
6	962.1621	42.22	-4.04	38.18	54.00	-15.82	QP	100	56	

**Test Results (30~1000MHz)**

Job No.: 18220WC00037401      Temp.(°C)/Hum.(%RH): 22.6°C/56%RH  
 Standard: FCC PART 15C      Power Source: AC 120V, 60Hz for HomeBase 2  
 Test Mode: TX Mode      Polarization: Vertical  
 Note:



No.	Freq. (MHz)	Reading (dBuV)	Factor (dB/m)	Result (dBuV/m)	Limit (dBuV/m)	Over Limit (dB)	Detector	Height (cm)	degree (deg)	Remark
1	40.2757	50.70	-14.63	36.07	40.00	-3.93	QP	100	0	
2	49.7068	49.51	-15.71	33.80	40.00	-6.20	QP	100	360	
3	81.2116	53.41	-18.57	34.84	40.00	-5.16	QP	100	0	
4	90.2205	52.40	-16.89	35.51	43.50	-7.99	QP	100	360	
5	151.5971	55.76	-21.27	34.49	43.50	-9.01	QP	100	0	
6	962.1621	44.75	-4.04	40.71	54.00	-13.29	QP	100	360	

Remark:

1. Results = Reading + Cable Loss +Ant Factor –Amplifier



## 5. 20DB Occupy Bandwidth Test

### 5.1. Test Standard and Limit

Test Standard	FCC Part15 C Section 15.231 (c)				
Test Limit	<p>According to FCC Part 15.231(c), The bandwidth of the emission shall be no wider than 0.25% of the center frequency for devices operating above 70MHz and below 900MHz. For devices operating above 900MHz, the emission shall be no wider than 0.5% of the center frequency. Bandwidth is determined at the points 20dB down from the modulated carrier.</p> <p>So the emission bandwidth limits have been calculated in below table:</p> <table border="1"> <thead> <tr> <th>Fundamental Frequency</th> <th>Limit of 20dB Bandwidth</th> </tr> </thead> <tbody> <tr> <td>433.92 MHz</td> <td><math>433920 \times 0.0025 = 1084.80 \text{ kHz}</math></td> </tr> </tbody> </table>	Fundamental Frequency	Limit of 20dB Bandwidth	433.92 MHz	$433920 \times 0.0025 = 1084.80 \text{ kHz}$
Fundamental Frequency	Limit of 20dB Bandwidth				
433.92 MHz	$433920 \times 0.0025 = 1084.80 \text{ kHz}$				

### 5.2. Test Setup

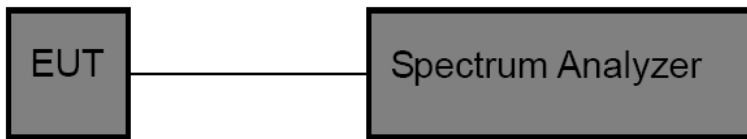

### 5.3. Test Procedure

1. Place the EUT on the table and set it in the continuously transmitting mode.
2. Remove the antenna from the EUT and then connect a low loss RF cable from the antenna port to the spectrum analyzer.
3. Set the spectrum analyzer as:  
 RBW = 10kHz, VBW $\geq$ 3\*RBW =30kHz,  
 Span= 500KHz  
 Detector= Peak  
 Trace mode= Max hold.  
 Sweep- auto couple.
4. Mark the peak frequency and -20dB (upper and lower) frequency.
5. Repeat until all the rest channels are investigated.

### 5.4. Test Data

Test Item	: 20dB Bandwidth	Test Mode	: Continuously transmitting
Test Voltage	: AC 120V, 60Hz for HomeBase 2	Temperature	: 23.6°C
Test Result	: PASS	Humidity	: 54%RH

Freq. (MHz)	Modulation Type	20dB Bandwidth (kHz)	Limit (kHz)	Results
433.92	GFSK	52.99	<1084.80	PASS

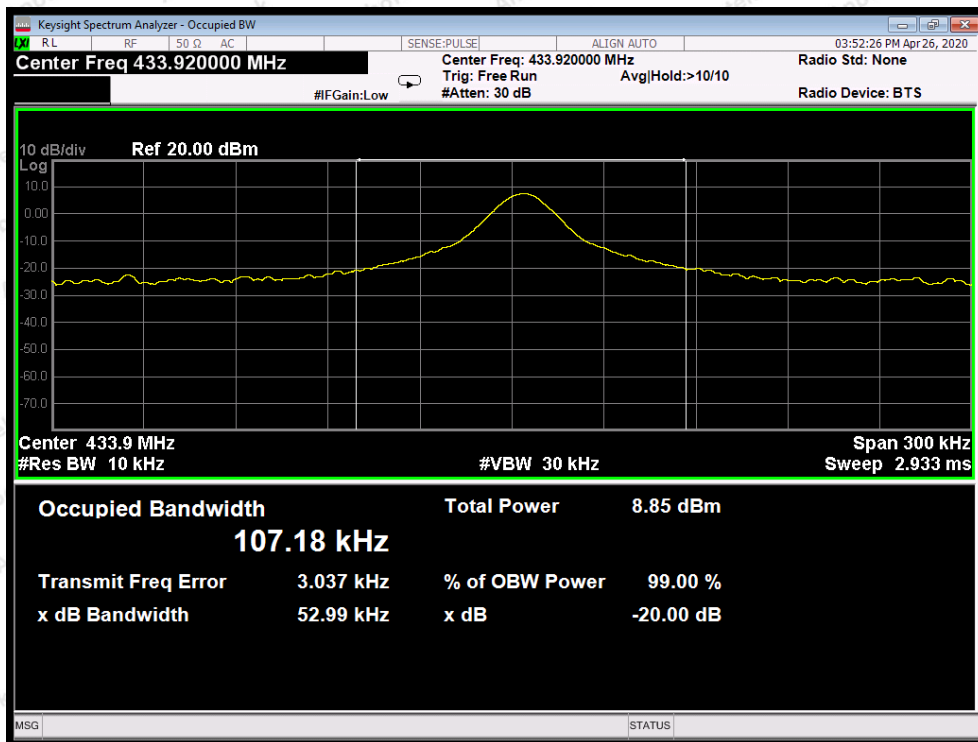

433.92MHz

## 6. Dwell Time Test

### 6.1. Test Standard and Limit

Test Standard	FCC Part 15.231(a)(1)
Test Limit	According to FCC Part 15.231(a)(1), A manually operated transmitter shall employ a switch that will automatically deactivate the transmitter within not more than 5 seconds of being released

### 6.2. Test Setup

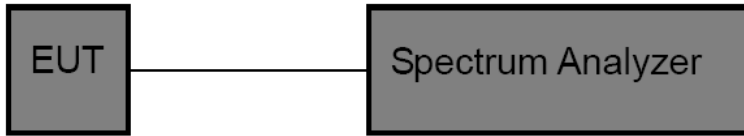

### 6.3. Test Procedure

1. Place the EUT on the table and set it in continuously transmitting mode. Remove the antenna from the EUT and then connect a low loss RF cable from the antenna port to the spectrum analyzer.
2. Set the spectrum analyzer as  
RBW=1000kHz, VBW= 1000 kHz, Span= 0Hz, Sweep Time= 20 Seconds.
3. Record the Delta mark time.

### 6.4. Test Data

Test Item	: Dwell Time	Test Mode	: Continuously transmitting
Test Voltage	: AC 120V, 60Hz for HomeBase 2	Temperature	: 23.6°C
Test Result	: PASS	Humidity	: 54%RH

Test Mode	Transmitting time(s)	Limit(s)	Result
GFSK mode	0.15	≤5	PASS

Please refer the following plot.



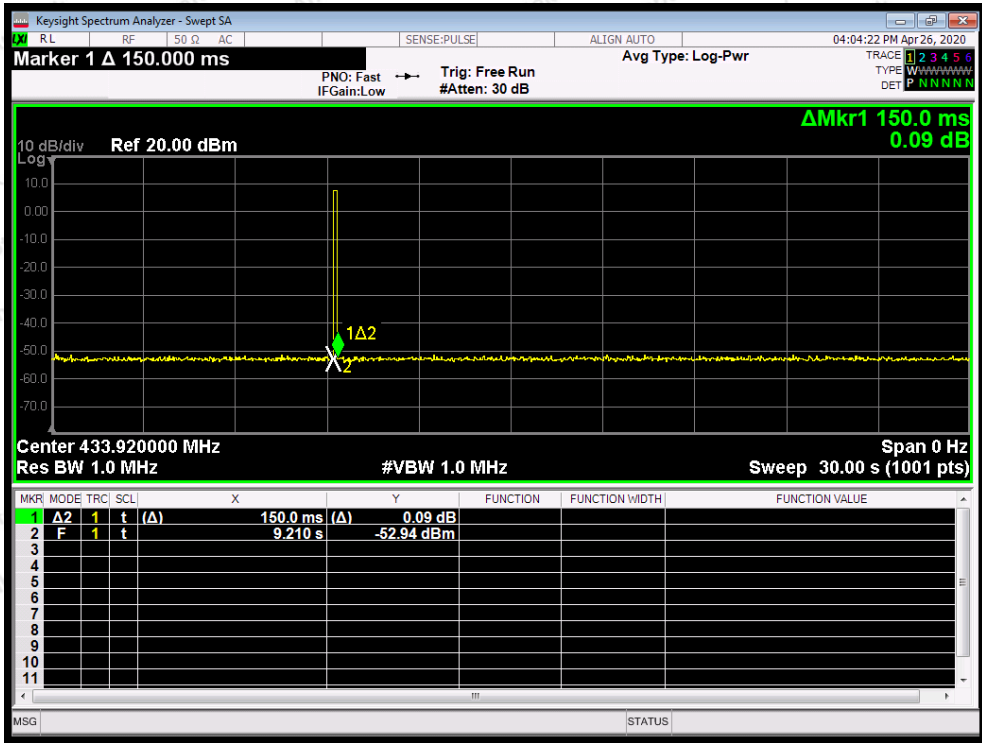

Dwell Time

## 7. Antenna Requirement

### 7.1. Test Standard and Requirement

Test Standard	FCC Part15 Section 15.203
Requirement	1) 15.203 requirement: An intentional radiator shall be designed to ensure that no antenna other than that furnished by the responsible party shall be used with the device. Antenna requirement must meet at least one of the following: 1) Antenna must be permanently attached to device. 2) The antenna must use a unique type of connector to attach to the device. 3) Device must be professionally installed. The installer shall be responsible for ensuring that the correct antenna is employed by the device.

### 7.2. Antenna Connected Construction

The antenna is a Spring antenna which permanently attached, and the best case gain of the antenna is 0 dBi. It complies with the standard requirement.

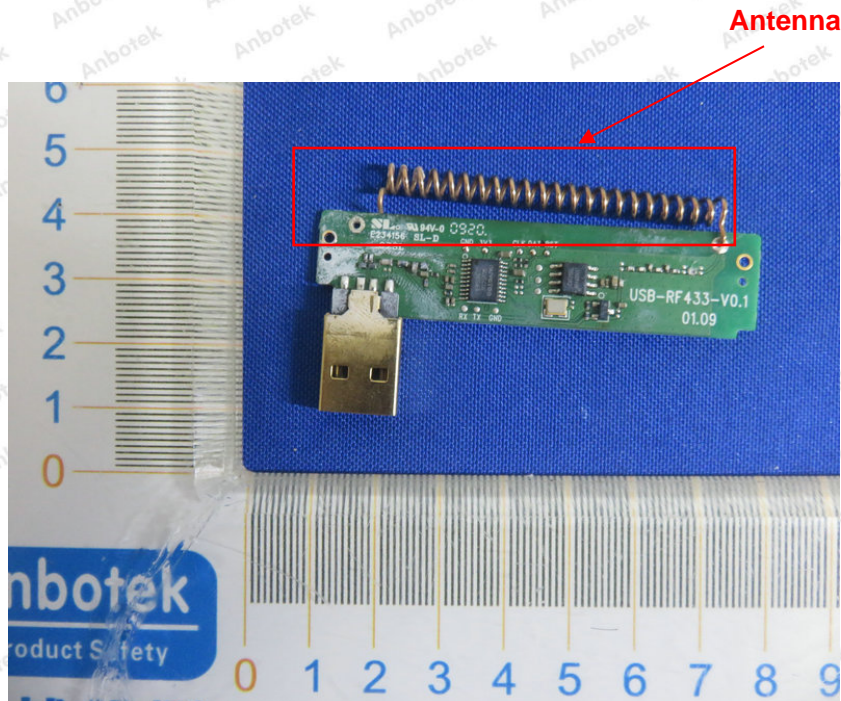

----- End of Report -----