FCC & IC Test Report

Report No.: AGC01110190726FE02

FCC ID : 2AOKB-A3909R
IC : 23451-A3909R
APPLICATION PURPOSE : Original Equipment
PRODUCT DESIGNATION : Soundcore Liberty 2 Pro, Soundcore Liberty 2
BRAND NAME : Soundcore
MODEL NAME : A3909R, A3913R
APPLICANT : Anker Innovations Limited
DATE OF ISSUE : Aug. 23, 2019
STANDARD(S) : FCC Part 15.247
ANSI C63.10: 2013
RSS-GEN: issue 5
RSS-247: issue 2
REPORT VERSION : V1.0

Attestation of Global Compliance (Shenzhen) Co., Ltd

CAUTION:

This report shall not be reproduced except in full without the written permission of the test laboratory and shall not be quoted out of context.

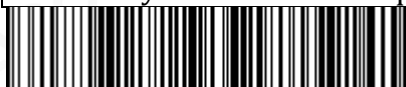

REPORT REVISE RECORD

| Report Version | Revise Time | Issued Date | Valid Version | Notes |
|----------------|-------------|---------------|---------------|-----------------|
| V1.0 | / | Aug. 23, 2019 | Valid | Initial Release |



TABLE OF CONTENTS

| | |
|--|-----------|
| 1. VERIFICATION OF COMPLIANCE | 5 |
| 2. GENERAL INFORMATION | 6 |
| 2.1. PRODUCT DESCRIPTION..... | 6 |
| 2.2. TABLE OF CARRIER FREQUENCIES | 6 |
| 2.3. RELATED SUBMITTAL(S)/GRANT(S) | 7 |
| 2.4. TEST METHODOLOGY | 7 |
| 2.5. SPECIAL ACCESSORIES..... | 7 |
| 2.6. EQUIPMENT MODIFICATIONS | 7 |
| 3. MEASUREMENT UNCERTAINTY | 8 |
| 4. DESCRIPTION OF TEST MODES | 9 |
| 5. SYSTEM TEST CONFIGURATION | 10 |
| 5.1. CONFIGURATION OF TESTED SYSTEM..... | 10 |
| 5.2. EQUIPMENT USED IN TESTED SYSTEM | 10 |
| 5.3. SUMMARY OF TEST RESULTS | 10 |
| 6. TEST FACILITY | 11 |
| 7. PEAK OUTPUT POWER | 12 |
| 7.1. MEASUREMENT PROCEDURE | 12 |
| 7.2. TEST SET-UP (BLOCK DIAGRAM OF CONFIGURATION) | 12 |
| 7.3. LIMITS AND MEASUREMENT RESULT | 13 |
| 8. 6 DB BANDWIDTH | 15 |
| 8.1. MEASUREMENT PROCEDURE | 15 |
| 8.2. TEST SET-UP (BLOCK DIAGRAM OF CONFIGURATION) | 15 |
| 8.3. LIMITS AND MEASUREMENT RESULTS | 15 |
| 9. CONDUCTED SPURIOUS EMISSION | 17 |
| 9.1. MEASUREMENT PROCEDURE | 17 |
| 9.2. TEST SET-UP (BLOCK DIAGRAM OF CONFIGURATION) | 17 |
| 9.3. MEASUREMENT EQUIPMENT USED | 17 |
| 9.4. LIMITS AND MEASUREMENT RESULT..... | 17 |
| 10. MAXIMUM CONDUCTED OUTPUT POWER SPECTRAL DENSITY | 22 |
| 10.1. MEASUREMENT PROCEDURE | 22 |
| 10.2. TEST SET-UP (BLOCK DIAGRAM OF CONFIGURATION) | 22 |
| 10.3. MEASUREMENT EQUIPMENT USED | 22 |
| 10.4. LIMITS AND MEASUREMENT RESULT..... | 22 |
| 11. RADIATED EMISSION | 24 |
| 11.1. MEASUREMENT PROCEDURE | 24 |
| 11.2. TEST SETUP | 25 |
| 11.3. LIMITS AND MEASUREMENT RESULT..... | 26 |
| 11.4. TEST RESULT | 26 |
| 12. FCC LINE CONDUCTED EMISSION TEST | 36 |
| 12.1. LIMITS OF LINE CONDUCTED EMISSION TEST | 36 |



| | |
|---|-----------|
| 12.2. BLOCK DIAGRAM OF LINE CONDUCTED EMISSION TEST | 36 |
| 12.3. PRELIMINARY PROCEDURE OF LINE CONDUCTED EMISSION TEST | 37 |
| 12.4. FINAL PROCEDURE OF LINE CONDUCTED EMISSION TEST | 37 |
| 12.5. TEST RESULT OF LINE CONDUCTED EMISSION TEST | 37 |
| APPENDIX A: PHOTOGRAPHS OF TEST SETUP | 38 |
| APPENDIX B: PHOTOGRAPHS OF EUT | 38 |



1. VERIFICATION OF COMPLIANCE

| | |
|---------------------------------|---|
| Applicant | Anker Innovations Limited |
| Address | Room 1318-19, Hollywood Plaza, 610 Nathan Road, Mongkok, Kowloon, Hongkong |
| Manufacturer | Anker Innovations Limited |
| Address | Room 1318-19, Hollywood Plaza, 610 Nathan Road, Mongkok, Kowloon, Hongkong |
| Factory | RISUNTEK INC |
| Address | Jiuwei Industrial Zone, Qishi Town, 523000 Dongguan City, Guangdong Province, P.R.China |
| Product Designation | Soundcore Liberty 2 Pro, Soundcore Liberty 2 |
| Brand Name | Soundcore |
| Test Model | A3909R |
| Series Model | A3913L |
| Difference Description | All the same except for the model name and speaker |
| Date of test | July 17, 2019 to Aug. 23, 2019 |
| Deviation | None |
| Condition of Test Sample | Normal |
| Test Result | Pass |
| Report Template | AGCRT-US-BLE/RF |

We hereby certify that:

The above equipment was tested by Attestation of Global Compliance (Shenzhen) Co., Ltd. The test data, data evaluation, test procedures, and equipment configurations shown in this report were made in accordance with the procedures given in ANSI C63.10 (2013) and the energy emitted by the sample EUT tested as described in this report is in compliance with radiated emission limits of FCC part 15.247 and RSS-247.

Prepared By

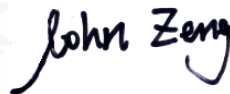

John Zeng
Project Engineer

Aug. 23, 2019

Reviewed By



Max Zhang
Reviewer

Aug. 23, 2019

Approved By



Forrest Lei
Authorized Officer

Aug. 23, 2019

2. GENERAL INFORMATION

2.1. PRODUCT DESCRIPTION

The EUT is designed as a “Soundcore Liberty 2 Pro, Soundcore Liberty 2”. It is designed by way of utilizing the GFSK technology to achieve the system operation.

A major technical description of EUT is described as following

| | |
|--|--|
| Operation Frequency | 2.402 GHz to 2.480GHz |
| RF Output Power | 7.967 dBm(Max) |
| Bluetooth Version | V5.0 |
| Modulation | BR <input checked="" type="checkbox"/> GFSK, EDR <input checked="" type="checkbox"/> π /4-DQPSK, <input checked="" type="checkbox"/> 8DPSK BLE <input checked="" type="checkbox"/> GFSK 1Mbps <input type="checkbox"/> GFSK 2Mbps |
| Number of channels | 40 Channel |
| Antenna Designation | PCB Antenna(Comply with requirements of the FCC part 15.203 and RSS-GEN chapter 6.8) |
| Antenna Gain | -1.20dBi |
| Hardware Version | V1.0 |
| Software Version | V1.07.02 |
| Power Supply | DC 3.7V by battery |
| Note: The BT function of EUT didn't work when charging. | |

2.2. TABLE OF CARRIER FREQUENCIES

| Frequency Band | Channel Number | Frequency |
|----------------|----------------|-----------|
| 2400~2483.5MHZ | 0 | 2402MHZ |
| | 1 | 2404MHZ |
| | : | : |
| | 38 | 2478 MHZ |
| | 39 | 2480 MHZ |



2.3. RELATED SUBMITTAL(S)/GRANT(S)

This submittal(s) (test report) is intended for **FCC ID:2AOKB-A3909R** filing to comply with the FCC Part 15.247 requirements.

This submittal(s) (test report) is intended for **IC:23451-A3909R** filing to comply with the RSS-247 requirements.

2.4. TEST METHODOLOGY

Both conducted and radiated testing was performed according to the procedures in ANSI C63.10 (2013). Radiated testing was performed at an antenna to EUT distance 3 meters.

2.5. SPECIAL ACCESSORIES

Refer to section 2.2.

2.6. EQUIPMENT MODIFICATIONS

Not available for this EUT intended for grant.



3. MEASUREMENT UNCERTAINTY

The reported uncertainty of measurement $y \pm U$, where expanded uncertainty U is based on a standard uncertainty multiplied by a coverage factor of $k=2$, providing a level of confidence of approximately 95%.

- Uncertainty of Conducted Emission, $U_c = \pm 3.2$ dB
- Uncertainty of Radiated Emission below 1GHz, $U_c = \pm 3.9$ dB
- Uncertainty of Radiated Emission above 1GHz, $U_c = \pm 4.8$ dB
- Uncertainty of total RF power, conducted, $U_c = \pm 0.8$ dB
- Uncertainty of RF power density, conducted, $U_c = \pm 2.6$ dB
- Uncertainty of spurious emissions, conducted, $U_c = \pm 2.7$ dB
- Uncertainty of Occupied Channel Bandwidth: $U_c = \pm 2$ %



4. DESCRIPTION OF TEST MODES

| NO. | TEST MODE DESCRIPTION |
|-----|-----------------------|
| 1 | Low channel TX |
| 2 | Middle channel TX |
| 3 | High channel TX |

- Note:1. Only the result of the worst case was recorded in the report, if no other cases.
 2. For Radiated Emission, 3axis were chosen for testing for each applicable mode.
 3. For Conducted Test method, a temporary antenna connector is provided by the manufacture.

Software Setting

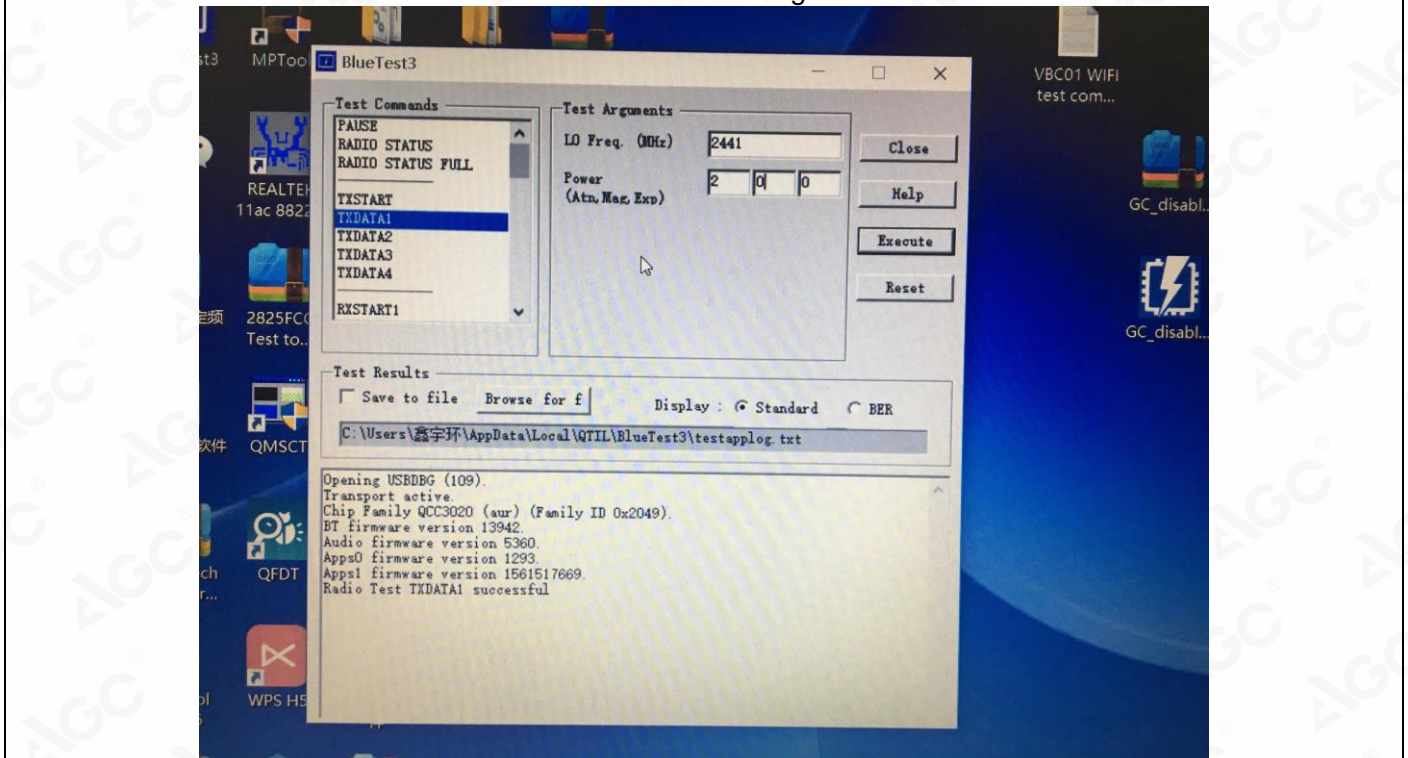

5. SYSTEM TEST CONFIGURATION

5.1. CONFIGURATION OF TESTED SYSTEM

Radiated Emission Configure :



Conducted Emission Configure :

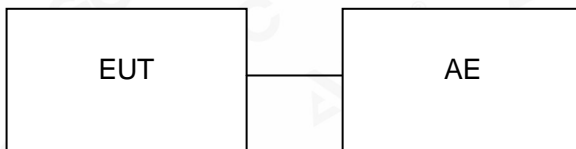

5.2. EQUIPMENT USED IN TESTED SYSTEM

| Item | Equipment | Model No. | ID or Specification | Remark |
|------|---|----------------|--|--------|
| 1 | Soundcore Liberty 2 Pro, Soundcore Liberty 2 | A3909R, A3913R | FCC ID: 2AOKB-A3909R IC: 23451-A3909R | EUT |
| 2 | Control Box | N/A | USB_TTL | AE |

5.3. SUMMARY OF TEST RESULTS

| ISED/FCC RULES | DESCRIPTION OF TEST | RESULT |
|---------------------------------|--|-----------|
| 15.247 (b)(3) RSS-247 5.4(d) | Peak Output Power | Compliant |
| 15.247 (a)(2) RSS-247 5.2(a) | 6 dB Bandwidth | Compliant |
| 15.247 (d) RSS-247 5.5 | Conducted Spurious Emission | Compliant |
| 15.247 (e) RSS-247 5.2(b) | Maximum Conducted Output Power Density | Compliant |
| 15.209 RSS-GEN 8.9 | Radiated Emission | Compliant |
| 15.207 RSS-GEN 8.8 | Conducted Emission | N/A |

Note: The EUT can not use the BT function with charging.

6. TEST FACILITY

| | |
|--|--|
| Test Site | Attestation of Global Compliance (Shenzhen) Co., Ltd |
| Location | 1-2/F, Building 19, Junfeng Industrial Park, Chongqing Road, Heping Community, Fuhai Street, Bao'an District, Shenzhen, Guangdong, China |
| Designation Number | CN1259 |
| FCC Test Firm Registration Number | 975832 |
| IC Designation Number | 24842 |
| A2LA Cert. No. | 5054.02 |
| Description | Attestation of Global Compliance(Shenzhen) Co., Ltd is accredited by A2LA |

TEST EQUIPMENT OF RADIATED EMISSION TEST

| Equipment | Manufacturer | Model | S/N | Cal. Date | Cal. Due |
|--------------------------------|----------------|--------------|------------|---------------|---------------|
| TEST RECEIVER | R&S | ESCI | 10096 | Jun. 12, 2019 | Jun. 26, 2020 |
| EXA Signal Analyzer | Aglient | N9010A | MY53470504 | Dec. 20, 2018 | Dec. 19, 2019 |
| 2.4GHz Fliter | EM Electronics | 2400-2500MHz | N/A | Feb. 27, 2019 | Feb. 26, 2020 |
| Attenuator | ZHINAN | E-002 | N/A | Aug. 28, 2018 | Aug. 27, 2019 |
| Horn antenna | SCHWARZBECK | BBHA 9170 | #768 | Jun. 12, 2019 | Jun. 26, 2020 |
| Active loop antenna (9K-30MHz) | ZHINAN | ZN30900C | 18051 | Jun. 14, 2018 | Jun. 13, 2020 |
| Double-Ridged Waveguide Horn | ETS LINDGREN | 3117 | 00034609 | May. 26, 2018 | May. 25, 2020 |
| Broadband Preamplifier | ETS LINDGREN | 3117PA | 00225134 | Oct. 25, 2018 | Oct. 24, 2019 |
| ANTENNA | SCHWARZBECK | VULB9168 | D69250 | Sep. 28, 2017 | Sep. 27, 2019 |



7. PEAK OUTPUT POWER

7.1. MEASUREMENT PROCEDURE

For peak power test:

1. Connect EUT RF output port to the Spectrum Analyzer through an RF attenuator
2. $RBW \geq DTS$ bandwidth
3. $VBW \geq 3 * RBW$.
4. $SPAN \geq VBW$.
5. Sweep: Auto.
6. Detector function: Peak.
7. Trace: Max hold.

Allow trace to stabilize. Use the marker-to-peak function to set the marker to the peak of the emission. The indicated level is the peak output power, after any corrections for external attenuators and cables.

7.2. TEST SET-UP (BLOCK DIAGRAM OF CONFIGURATION) PEAK POWER TEST SETUP

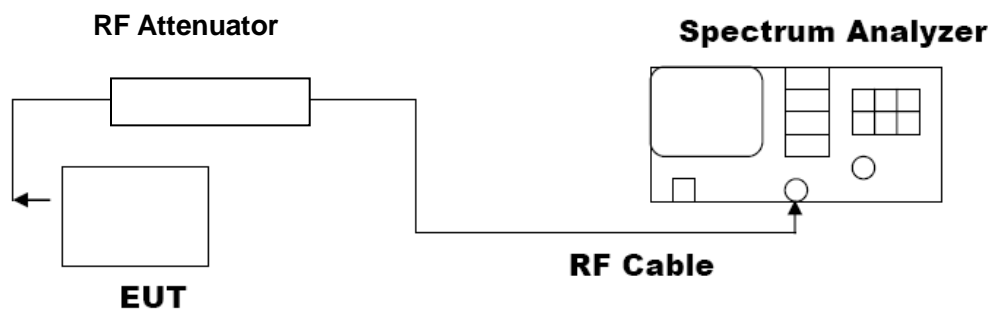

7.3. LIMITS AND MEASUREMENT RESULT

| PEAK OUTPUT POWER MEASUREMENT RESULT FOR GFSK MOUDULATION | | | |
|--|------------------|-------------------------|--------------|
| Frequency (GHz) | Peak Power (dBm) | Applicable Limits (dBm) | Pass or Fail |
| 2.402 | 7.967 | 30 | Pass |
| 2.440 | 7.966 | 30 | Pass |
| 2.480 | 7.964 | 30 | Pass |

CH0

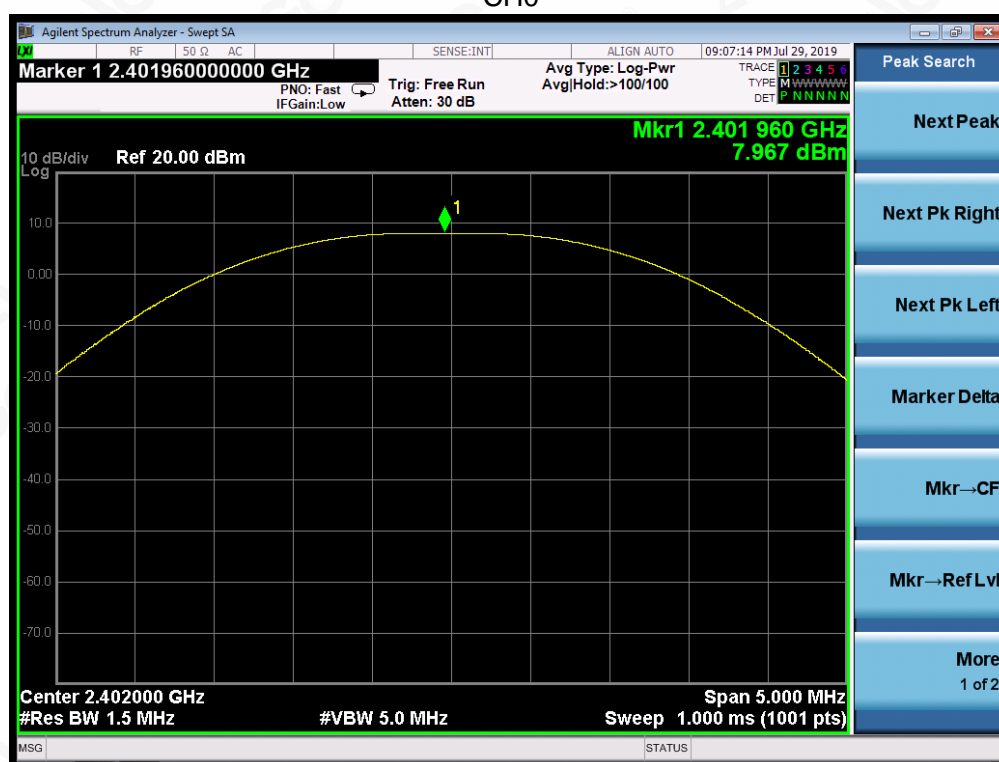

Attestation of Global Compliance

Attestation of Global Compliance(Shenzhen)Co.,Ltd.

Add: 2/F., Building 2, Sanwei Chaxi Industrial Park, Sanwei Community,
Hangcheng Street, Bao'an District, Shenzhen, Guangdong, China

Tel: +86-755 2523 4088

E-mail: agc@agc-cert.com

Service Hotline: 400 089 2118

CH19

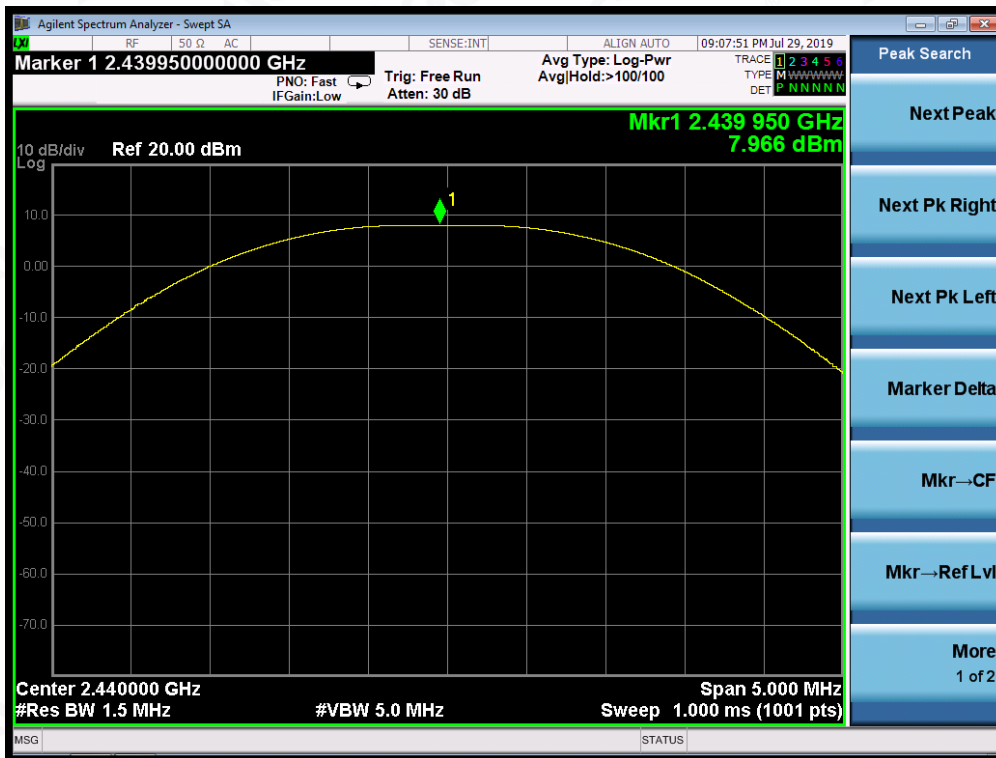

CH39

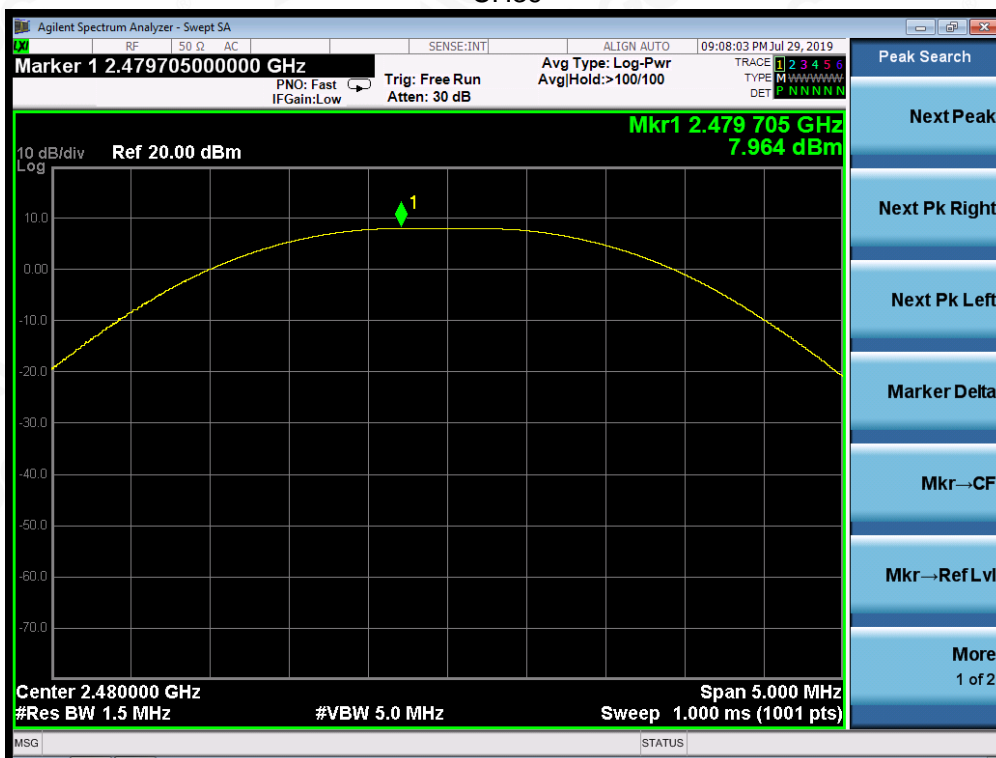

Attestation of Global Compliance

Attestation of Global Compliance(Shenzhen)Co.,Ltd.

Add: 2/F., Building 2, Sanwei Chaxi Industrial Park, Sanwei Community,
Hangcheng Street, Bao'an District, Shenzhen, Guangdong, China

Tel: +86-755 2523 4088

E-mail: agc@agc-cert.com

Service Hotline: 400 089 2118

8. 6 DB BANDWIDTH

8.1. MEASUREMENT PROCEDURE

1. Connect EUT RF output port to the Spectrum Analyzer through an RF attenuator
2. Set the EUT Work on the top, the middle and the bottom operation frequency individually.
3. Set SPA Centre Frequency = Operation Frequency, RBW= 100 KHz, VBW \geq 3 \times RBW.
4. Set SPA Trace 1 Max hold, then View.

Note: The EUT was tested according to ANSI C63.10 for compliance to FCC PART 15.247 requirements.

8.2. TEST SET-UP (BLOCK DIAGRAM OF CONFIGURATION)

The same as described in section 7.2.

8.3. LIMITS AND MEASUREMENT RESULTS

| LIMITS AND MEASUREMENT RESULT | | | |
|-------------------------------|-------------------|-------|----------|
| Applicable Limits | Applicable Limits | | |
| | Test Data (kHz) | | Criteria |
| >500KHZ | Low Channel | 720.3 | PASS |
| | Middle Channel | 709.4 | PASS |
| | High Channel | 706.0 | PASS |

TEST PLOT OF BANDWIDTH FOR LOW CHANNEL

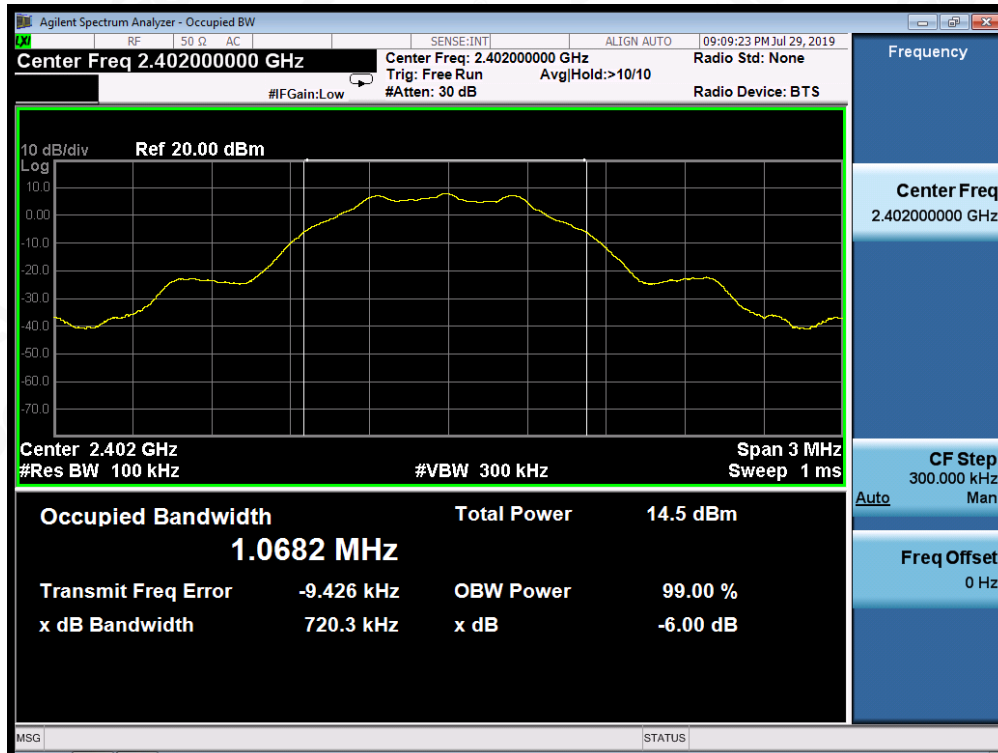

TEST PLOT OF BANDWIDTH FOR MIDDLE CHANNEL



TEST PLOT OF BANDWIDTH FOR HIGH CHANNEL

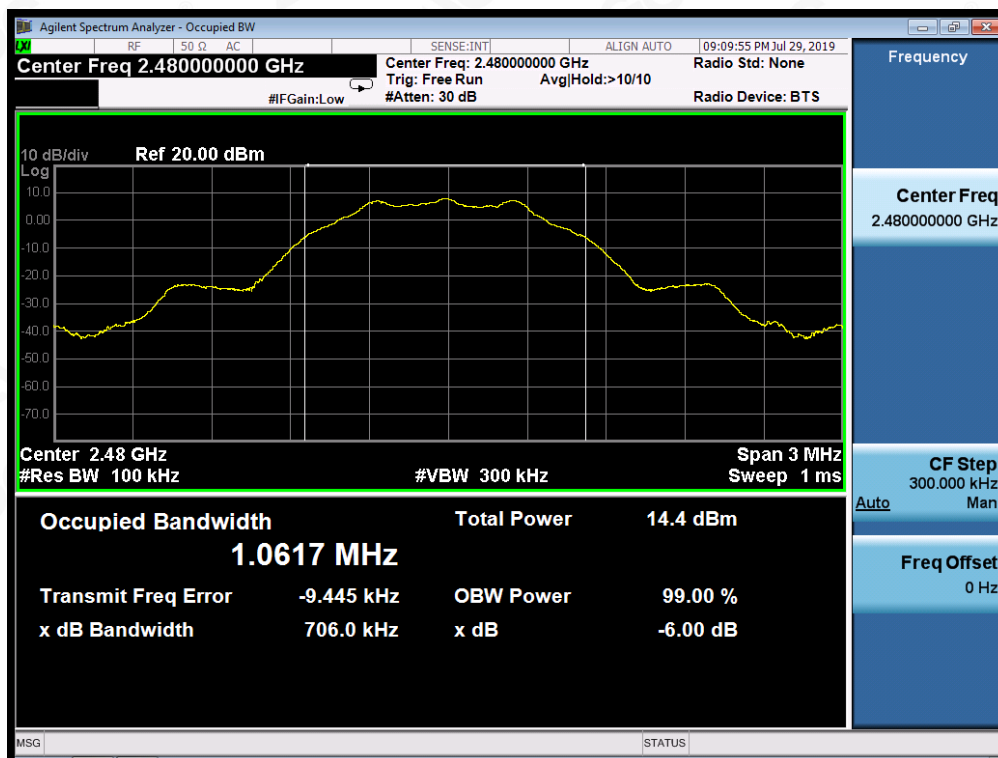

Attestation of Global Compliance

Attestation of Global Compliance(Shenzhen)Co.,Ltd.
 Add: 2/F., Building 2, Sanwei Chaxi Industrial Park, Sanwei Community,
 Hangcheng Street, Bao'an District, Shenzhen, Guangdong, China
 Tel: +86-755 2523 4088 | E-mail: agc@agc-cert.com | Service Hotline: 400 089 2118

9. CONDUCTED SPURIOUS EMISSION

9.1. MEASUREMENT PROCEDURE

1. Connect EUT RF output port to the Spectrum Analyzer through an RF attenuator
2. Set the EUT Work on the top, the middle and the bottom operation frequency individually.
3. Set SPA Trace 1 Max hold, then View.

Note: The EUT was tested according to ANSI C63.10 for compliance to FCC PART 15.247 requirements.

9.2. TEST SET-UP (BLOCK DIAGRAM OF CONFIGURATION)

The same as described in section 7.2.

9.3. MEASUREMENT EQUIPMENT USED

The same as described in section 6.

9.4. LIMITS AND MEASUREMENT RESULT

| LIMITS AND MEASUREMENT RESULT | | |
|--|--|--------------|
| Applicable Limits | Measurement Result | |
| | Test Data | Criteria |
| In any 100 KHz Bandwidth Outside the frequency band in which the spread spectrum intentional radiator is operating, the radio frequency power that is produce by the intentional radiator shall be at least 20 dB below that in 100KHz bandwidth within the band that contains the highest level of the desired power. | At least -20dBc than the reference level | PASS PASS |



**TEST RESULT FOR ENTIRE FREQUENCY RANGE
GFSK MODULATION IN LOW CHANNEL**

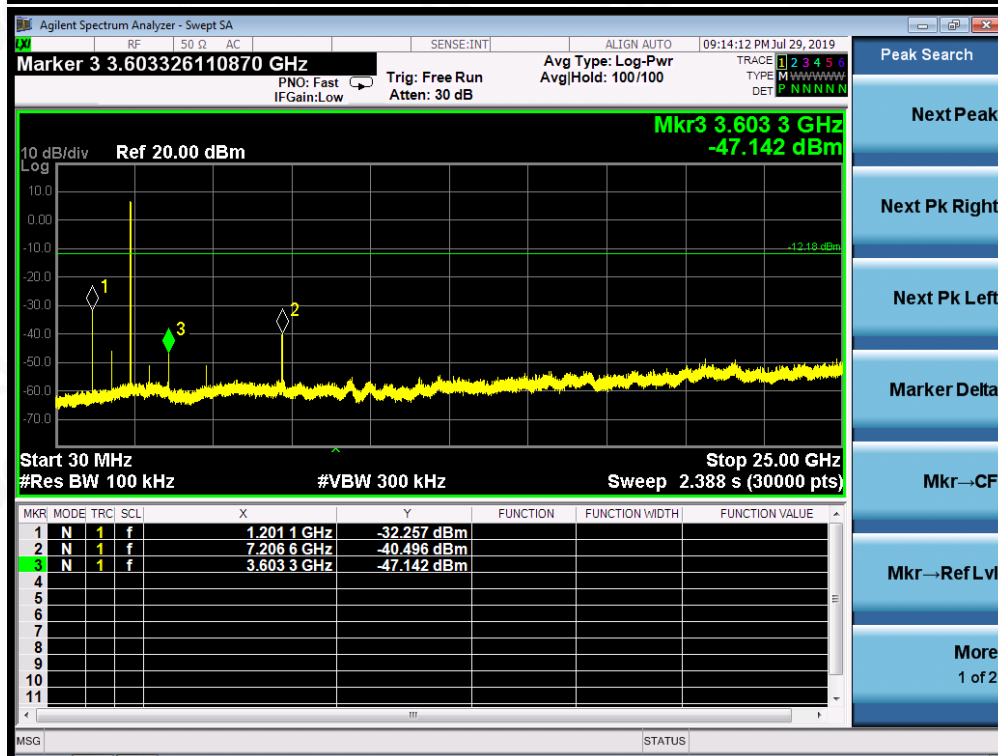

Attestation of Global Compliance

Attestation of Global Compliance(Shenzhen)Co.,Ltd.
Add: 2/F., Building 2, Sanwei Chaxi Industrial Park, Sanwei Community,
Hangcheng Street, Bao'an District, Shenzhen, Guangdong, China
Tel: +86-755 2523 4088 E-mail: agc@agc-cert.com Service Hotline:400 089 2118

GFSK MODULATION IN MIDDLE CHANNEL

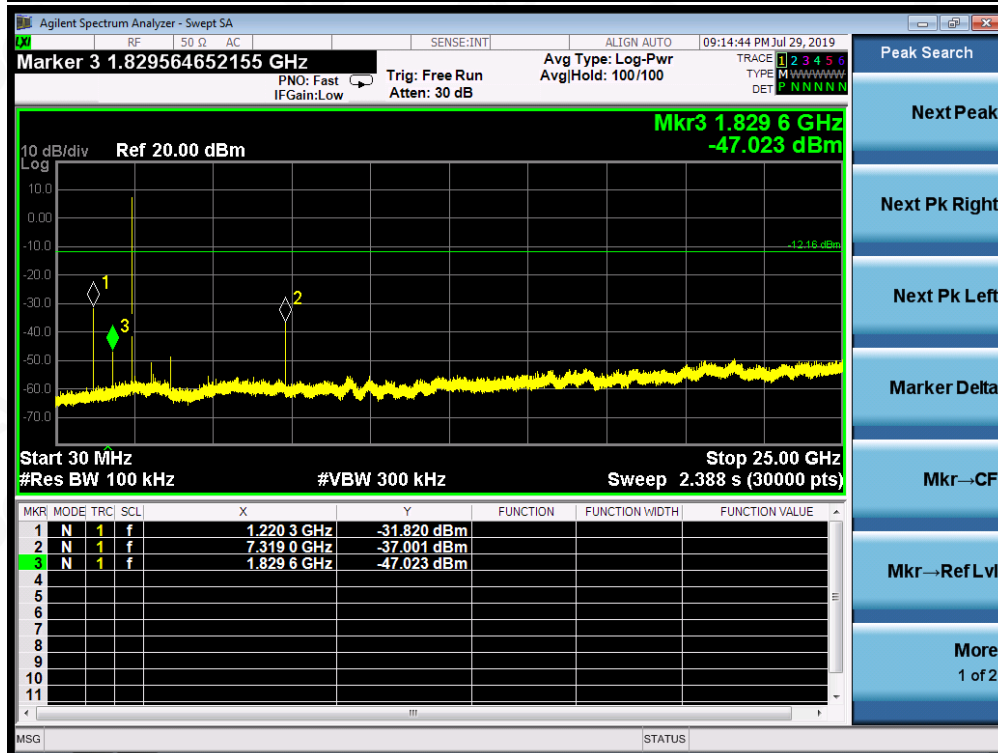

Attestation of Global Compliance

Attestation of Global Compliance(Shenzhen)Co.,Ltd.

Add: 2/F., Building 2, Sanwei Chaxi Industrial Park, Sanwei Community,
Hangcheng Street, Bao'an District, Shenzhen, Guangdong, China

Tel: +86-755 2523 4088

E-mail: agc@agc-cert.com

Service Hotline: 400 089 2118

GFSK MODULATION IN HIGH CHANNEL

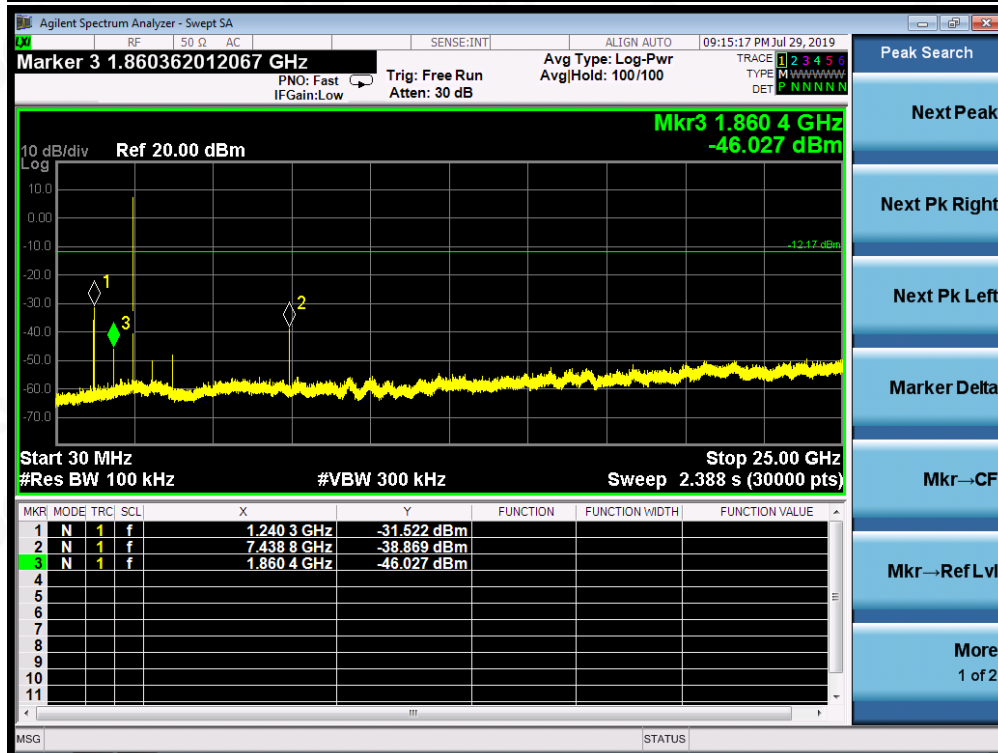

Note: The peak emissions without marker on the above plots are fundamental wave and need not to compare with the limit.



Attestation of Global Compliance

Attestation of Global Compliance(Shenzhen)Co.,Ltd.

Add: 2/F., Building 2, Sanwei Chaxi Industrial Park, Sanwei Community,
Hangcheng Street, Bao'an District, Shenzhen, Guangdong, China

Tel: +86-755 2523 4088 E-mail: agc@agc-cert.com Service Hotline:400 089 2118

TEST RESULT FOR BAND EDGE GFSK MODULATION IN LOW CHANNEL

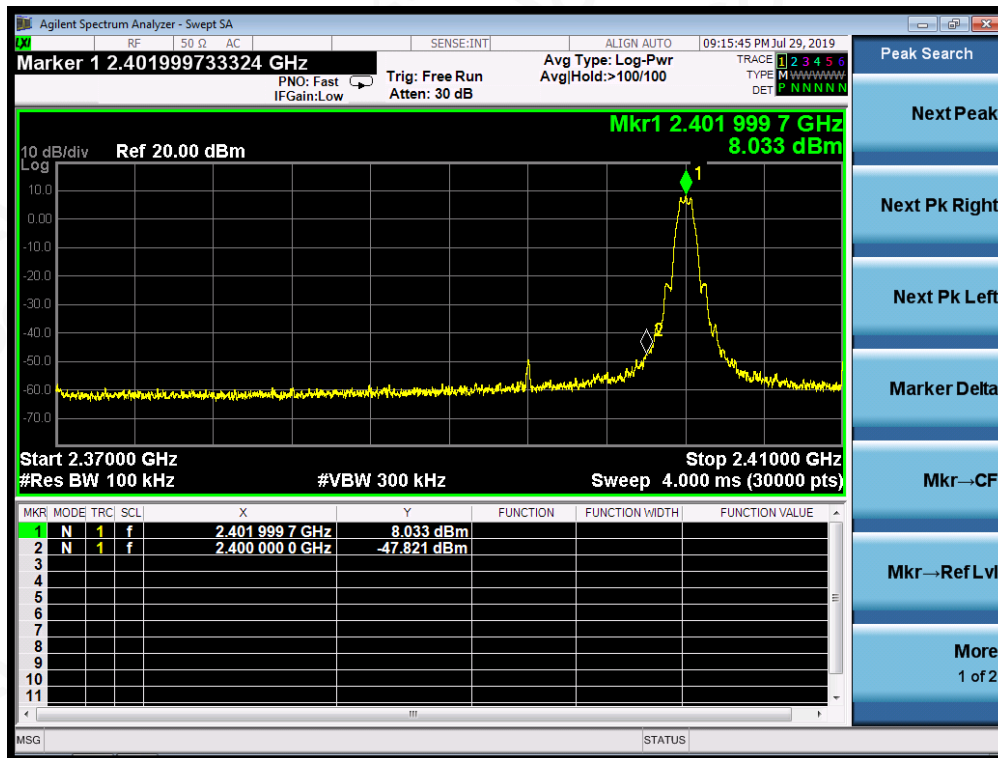

GFSK MODULATION IN HIGH CHANNEL

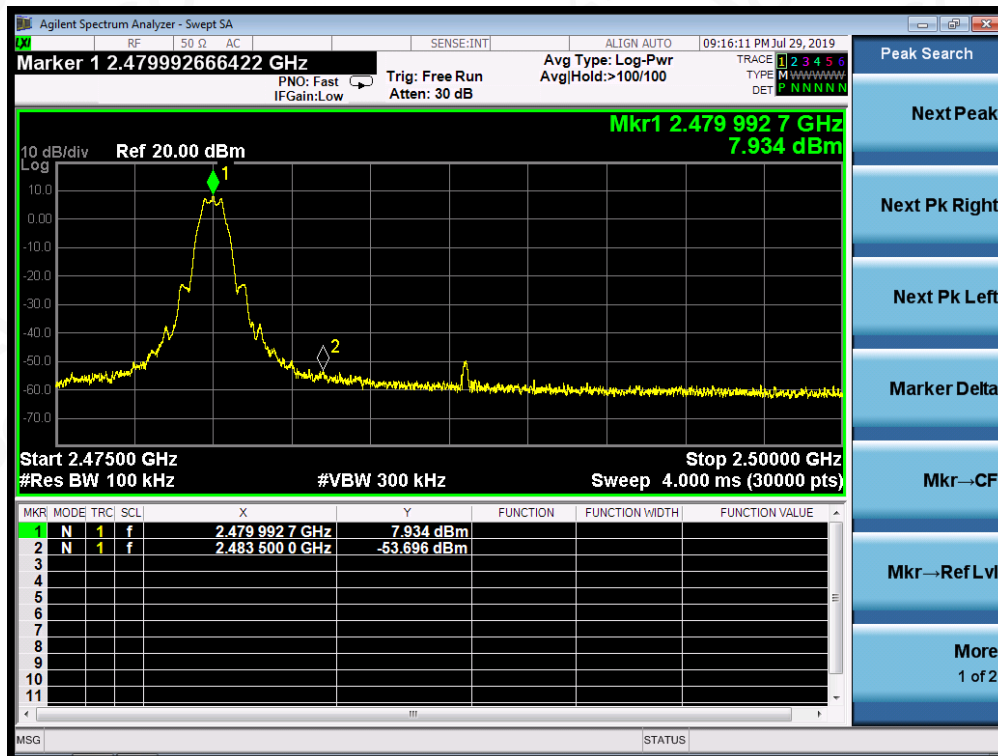

Attestation of Global Compliance

Attestation of Global Compliance(Shenzhen)Co.,Ltd.
Add: 2/F., Building 2, Sanwei Chaxi Industrial Park, Sanwei Community,
Hangcheng Street, Bao'an District, Shenzhen, Guangdong, China
Tel: +86-755 2523 4088 E-mail: agc@agc-cert.com Service Hotline:400 089 2118

10. MAXIMUM CONDUCTED OUTPUT POWER SPECTRAL DENSITY

10.1. MEASUREMENT PROCEDURE

- (1). Connect EUT RF output port to the Spectrum Analyzer through an RF attenuator
- (2). Set the EUT Work on the top, the middle and the bottom operation frequency individually.
- (3). Set SPA Trace 1 Max hold, then View.

Note: The method of PKPSD in the KDB 558074 item 10.2 was used in this testing.

10.2. TEST SET-UP (BLOCK DIAGRAM OF CONFIGURATION)

Refer To Section 7.2.

10.3. MEASUREMENT EQUIPMENT USED

Refer To Section 6.

10.4. LIMITS AND MEASUREMENT RESULT

| Channel No. | PSD (dBm/3kHz) | Limit (dBm/3kHz) | Result |
|----------------|----------------|------------------|--------|
| Low Channel | -7.011 | 8 | Pass |
| Middle Channel | -6.969 | 8 | Pass |
| High Channel | -6.861 | 8 | Pass |

TEST PLOT OF SPECTRAL DENSITY FOR LOW CHANNEL



TEST PLOT OF SPECTRAL DENSITY FOR MIDDLE CHANNEL

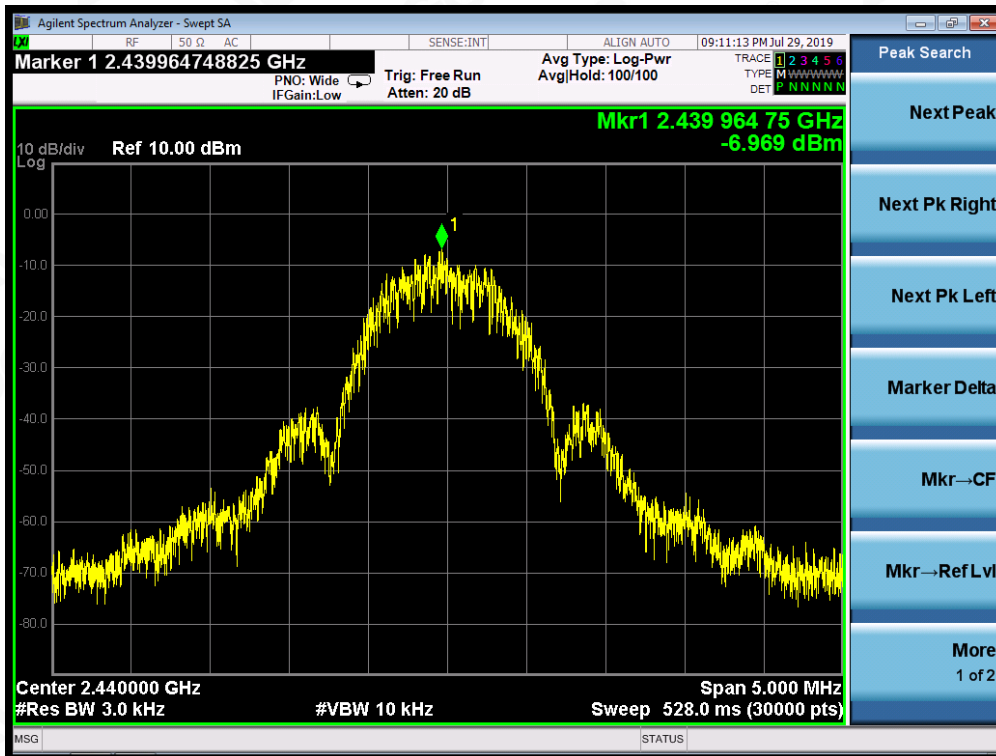

TEST PLOT OF SPECTRAL DENSITY FOR HIGH CHANNEL

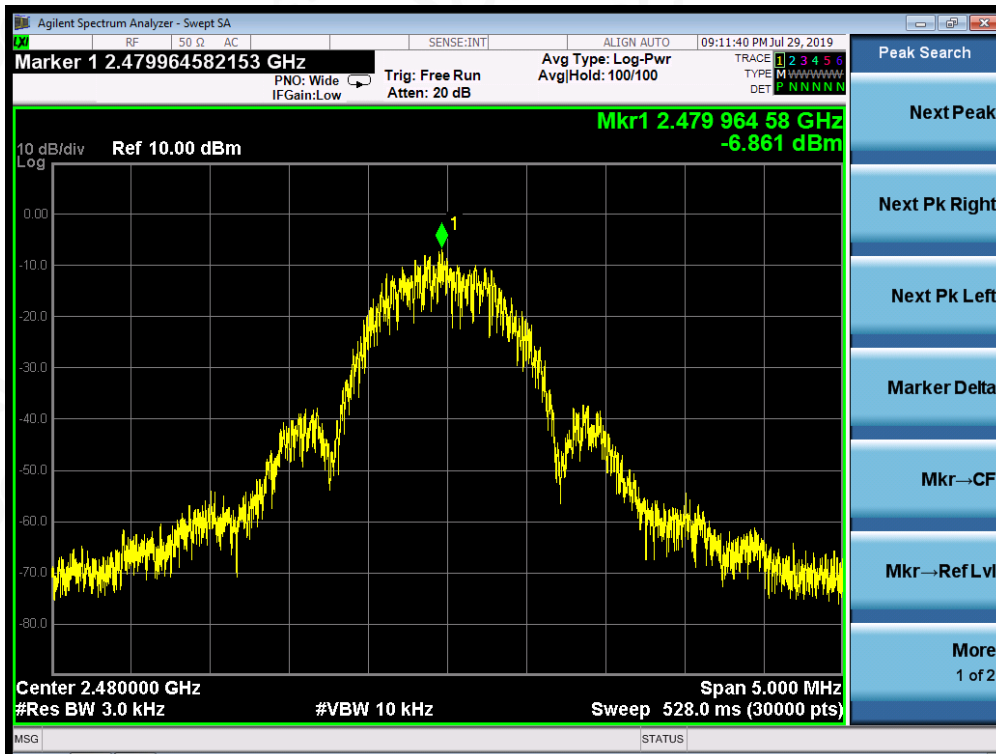

Attestation of Global Compliance

Attestation of Global Compliance(Shenzhen)Co.,Ltd.

Add: 2/F., Building 2, Sanwei Chaxi Industrial Park, Sanwei Community,
Hangcheng Street, Bao'an District, Shenzhen, Guangdong, China

Tel: +86-755 2523 4088

E-mail: agc@agc-cert.com

Service Hotline: 400 089 2118

11. RADIATED EMISSION

11.1. MEASUREMENT PROCEDURE

1. The EUT was placed on the top of the turntable 0.8 or 1.5 meter above ground. The phase center of the receiving antenna mounted on the top of a height-variable antenna tower was placed 3 meters far away from the turntable.
2. Power on the EUT and all the supporting units. The turntable was rotated by 360 degrees to determine the position of the highest radiation.
3. The height of the broadband receiving antenna was varied between one meter and four meters above ground to find the maximum emissions field strength of both horizontal and vertical polarization.
4. For each suspected emissions, the antenna tower was scan (from 1 M to 4 M) and then the turntable was rotated (from 0 degree to 360 degrees) to find the maximum reading.
5. Set the test-receiver system to Peak or CISPR quasi-peak Detect Function with specified bandwidth under Maximum Hold Mode.
6. For emissions above 1GHz, use 1MHz RBW and 3MHz VBW for peak reading. Place the measurement antenna away from each area of the EUT determined to be a source of emissions at the specified measurement distance, while keeping the measurement antenna aimed at the source of emissions at each frequency of significant emissions, with polarization oriented for maximum response. The measurement antenna may have to be higher or lower than the EUT, depending on the radiation pattern of the emission and staying aimed at the emission source for receiving the maximum signal. The final measurement antenna elevation shall be that which maximizes the emissions. The measurement antenna elevation for maximum emissions shall be restricted to a range of heights of from 1 m to 4 m above the ground or reference ground plane.
7. When the radiated emissions limits are expressed in terms of the average value of the emissions, and pulsed operation is employed, the measurement field strength shall be determined by averaging over one complete pulse train, including blanking intervals, as long as the pulse train does not exceed 0.1 seconds. As an alternative (provided the transmitter operates for longer than 0.1 seconds) or in cases where the pulse train exceeds 0.1 seconds, the measured field strength shall be determined from the average absolute voltage during a 0.1 second interval during which the field strength is at its maximum values.
8. If the emissions level of the EUT in peak mode was 3 dB lower than the average limit specified, then testing will be stopped and peak values of EUT will be reported, otherwise, the emissions which do not have 3 dB margin will be repeated one by one using the quasi-peak method for below 1GHz.
9. For testing above 1GHz, the emissions level of the EUT in peak mode was lower than average limit (that means the emissions level in peak mode also complies with the limit in average mode), then testing will be stopped and peak values of EUT will be reported, otherwise, the emissions will be measured in average mode again and reported.
10. In case the emission is lower than 30MHz, loop antenna has to be used for measurement and the recorded data should be QP measured by receiver. High - Low scan is not required in this case.

11.2. TEST SETUP

Radiated Emission Test-Setup Frequency Below 30MHz

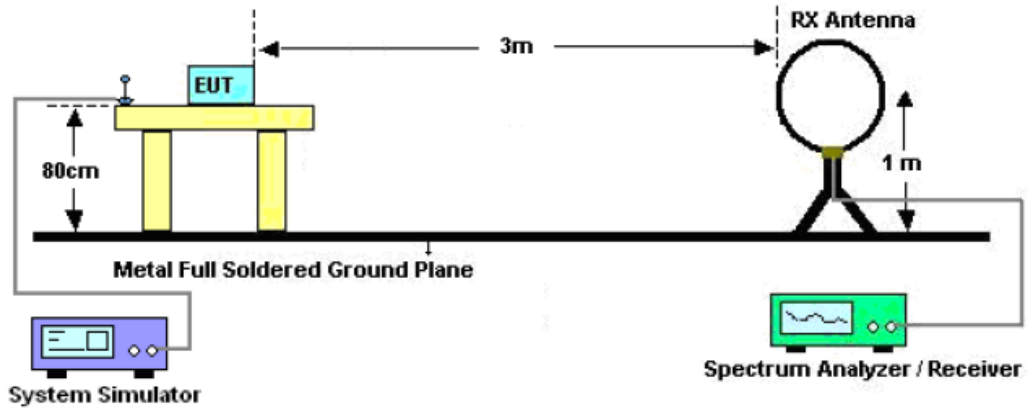

RADIATED EMISSION TEST SETUP 30MHz-1000MHz

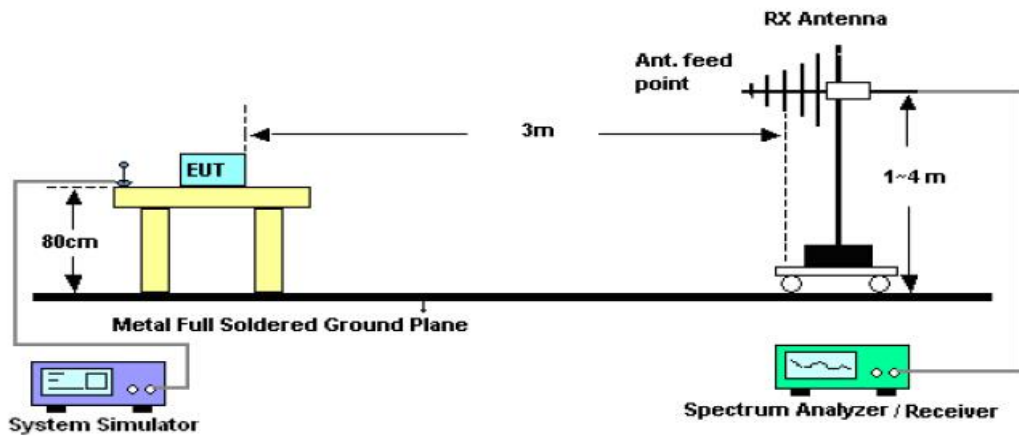

RADIATED EMISSION TEST SETUP ABOVE 1000MHz

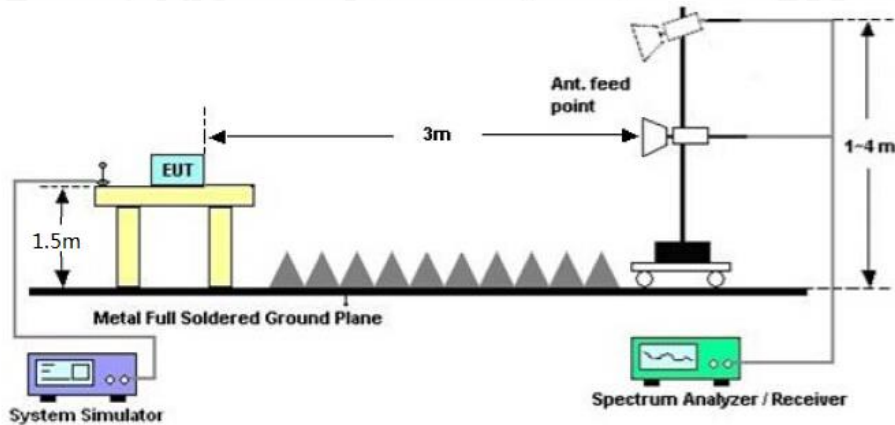

11.3. LIMITS AND MEASUREMENT RESULT

15.209 Limit in the below table has to be followed

| Frequencies (MHz) | Field Strength (micorvolts/meter) | Measurement Distance (meters) |
|--------------------------|--|--------------------------------------|
| 0.009~0.490 | 2400/F(KHz) | 300 |
| 0.490~1.705 | 24000/F(KHz) | 30 |
| 1.705~30.0 | 30 | 30 |
| 30~88 | 100 | 3 |
| 88~216 | 150 | 3 |
| 216~960 | 200 | 3 |
| Above 960 | 500 | 3 |

Note: All modes were tested For restricted band radiated emission, the test records reported below are the worst result compared to other modes.

11.4. TEST RESULT

RADIATED EMISSION BELOW 30MHZ

No emission found between lowest internal used/generated frequencies to 30MHz.



RADIATED EMISSION BELOW 1GHZ

| | | | |
|--------------------|-------------------------|--------------------------|----------------|
| EUT | Soundcore Liberty 2 Pro | Model Name | A3909R |
| Temperature | 25° C | Relative Humidity | 55.4% |
| Pressure | 960hPa | Test Voltage | Normal Voltage |
| Test Mode | Mode 1 | Antenna | Horizontal |

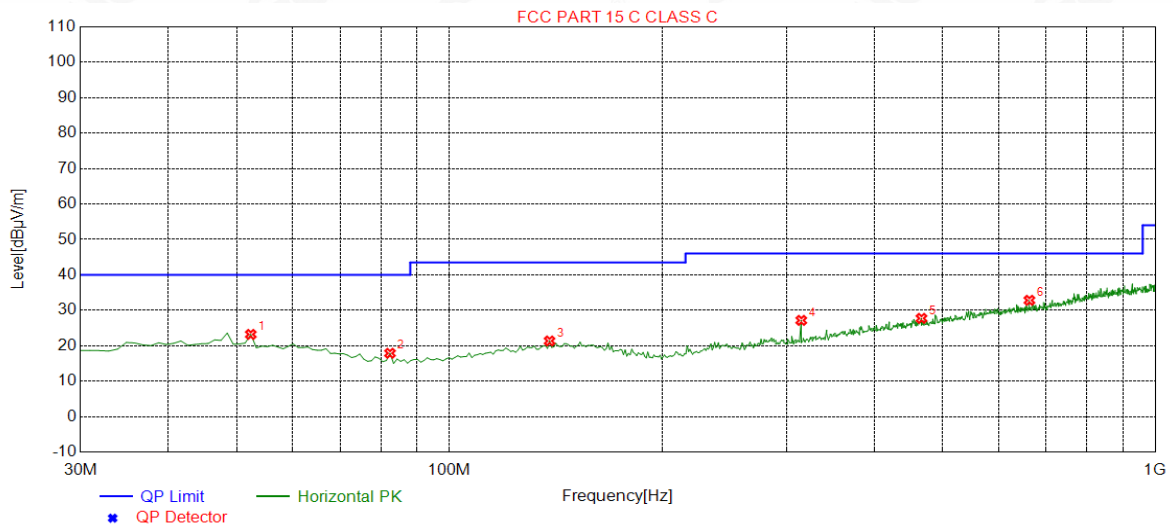

| NO. | Freq. [MHz] | Level [dBuV/m] | Factor [dB] | Limit [dBuV/m] | Margin [dB] | Height [cm] | Angle [°] | Polarity |
|-----|-------------|----------------|-------------|----------------|-------------|-------------|-----------|------------|
| 1 | 52.3100 | 23.20 | 14.49 | 40.00 | 16.80 | 150 | 14 | Horizontal |
| 2 | 82.3800 | 17.88 | 10.17 | 40.00 | 22.12 | 150 | 296 | Horizontal |
| 3 | 138.6400 | 21.35 | 14.78 | 43.50 | 22.15 | 150 | 245 | Horizontal |
| 4 | 315.1800 | 27.16 | 16.48 | 46.00 | 18.84 | 100 | 5 | Horizontal |
| 5 | 466.5000 | 27.73 | 21.34 | 46.00 | 18.27 | 150 | 343 | Horizontal |
| 6 | 663.4100 | 32.82 | 25.35 | 46.00 | 13.18 | 100 | 352 | Horizontal |

RESULT: PASS



Attestation of Global Compliance

Attestation of Global Compliance(Shenzhen)Co.,Ltd.

Add: 2/F., Building 2, Sanwei Chaxi Industrial Park, Sanwei Community,
Hangcheng Street, Bao'an District, Shenzhen, Guangdong, China

Tel: +86-755 2523 4088

E-mail: agc@agc-cert.com

Service Hotline: 400 089 2118

| | | | |
|-------------|-------------------------|-------------------|----------------|
| EUT | Soundcore Liberty 2 Pro | Model Name | A3909R |
| Temperature | 25° C | Relative Humidity | 55.4% |
| Pressure | 960hPa | Test Voltage | Normal Voltage |
| Test Mode | Mode 1 | Antenna | Vertical |

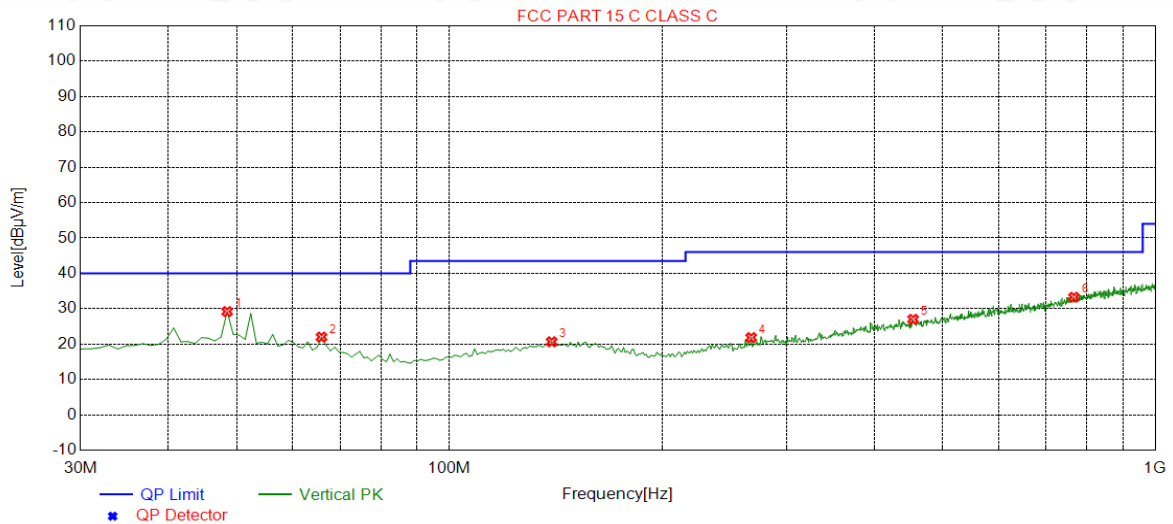

| NO. | Fre q. [MHz] | Level [dBuV/m] | Factor [dB] | Limit [dBuV/m] | Margin [dB] | Height [cm] | Angle [°] | Polarity |
|-----|--------------|----------------|-------------|----------------|-------------|-------------|-----------|----------|
| 1 | 48.4300 | 29.20 | 14.71 | 40.00 | 10.80 | 100 | 109 | Vertical |
| 2 | 65.8900 | 21.98 | 12.93 | 40.00 | 18.02 | 100 | 232 | Vertical |
| 3 | 139.6100 | 20.66 | 14.85 | 43.50 | 22.84 | 100 | 347 | Vertical |
| 4 | 267.6500 | 21.84 | 15.21 | 46.00 | 24.16 | 100 | 44 | Vertical |
| 5 | 453.8900 | 27.02 | 21.06 | 46.00 | 18.98 | 100 | 227 | Vertical |
| 6 | 767.2000 | 33.26 | 27.63 | 46.00 | 12.74 | 100 | 212 | Vertical |

RESULT: PASS

Note: 1. Factor=Antenna Factor + Cable loss, Margin=Measurement-Limit.

2. All test modes had been tested. The mode 1 is the worst case and recorded in the report.



Attestation of Global Compliance

Attestation of Global Compliance(Shenzhen)Co.,Ltd.

Add: 2/F., Building 2, Sanwei Chaxi Industrial Park, Sanwei Community, Hangcheng Street, Bao'an District, Shenzhen, Guangdong, China

Tel: +86-755 2523 4088

E-mail: agc@agc-cert.com

Service Hotline: 400 089 2118

RADIATED EMISSION ABOVE 1GHZ

| | | | |
|--------------------|-------------------------|--------------------------|----------------|
| EUT | Soundcore Liberty 2 Pro | Model Name | A3909R |
| Temperature | 25° C | Relative Humidity | 55.4% |
| Pressure | 960hPa | Test Voltage | Normal Voltage |
| Test Mode | Mode 1 | Antenna | Horizontal |

| Frequency (MHz) | Meter Reading (dBμV) | Factor (dB) | Emission Level (dBμV/m) | Limits (dBμV/m) | Margin (dB) | Value Type |
|--------------------|-------------------------|----------------|----------------------------|--------------------|----------------|------------|
| 4804.000 | 46.77 | 0.08 | 46.85 | 74 | -27.15 | peak |
| 4804.000 | 43.34 | 0.08 | 43.42 | 54 | -10.58 | AVG |
| 7206.000 | 42.76 | 2.21 | 44.97 | 74 | -29.03 | peak |
| 7206.000 | 39.67 | 2.21 | 41.88 | 54 | -12.12 | AVG |
| | | | | | | |
| | | | | | | |

Remark:

Factor = Antenna Factor + Cable Loss – Pre-amplifier.

| | | | |
|--------------------|-------------------------|--------------------------|----------------|
| EUT | Soundcore Liberty 2 Pro | Model Name | A3909R |
| Temperature | 25° C | Relative Humidity | 55.4% |
| Pressure | 960hPa | Test Voltage | Normal Voltage |
| Test Mode | Mode 1 | Antenna | Vertical |

| Frequency (MHz) | Meter Reading (dBμV) | Factor (dB) | Emission Level (dBμV/m) | Limits (dBμV/m) | Margin (dB) | Value Type |
|--------------------|-------------------------|----------------|----------------------------|--------------------|----------------|------------|
| 4804.000 | 45.85 | 0.08 | 45.93 | 74 | -28.07 | peak |
| 4804.000 | 42.72 | 0.08 | 42.8 | 54 | -11.2 | AVG |
| 7206.000 | 41.54 | 2.21 | 43.75 | 74 | -30.25 | peak |
| 7206.000 | 38.63 | 2.21 | 40.84 | 54 | -13.16 | AVG |
| | | | | | | |
| | | | | | | |

Remark:

Factor = Antenna Factor + Cable Loss – Pre-amplifier.



| | | | |
|--------------------|-------------------------|--------------------------|----------------|
| EUT | Soundcore Liberty 2 Pro | Model Name | A3909R |
| Temperature | 25° C | Relative Humidity | 55.4% |
| Pressure | 960hPa | Test Voltage | Normal Voltage |
| Test Mode | Mode 2 | Antenna | Horizontal |

| Frequency (MHz) | Meter Reading (dBμV) | Factor (dB) | Emission Level (dBμV/m) | Limits (dBμV/m) | Margin (dB) | Value Type |
|-----------------|----------------------|-------------|-------------------------|-----------------|-------------|------------|
| 4880.000 | 45.59 | 0.14 | 45.73 | 74 | -28.27 | peak |
| 4880.000 | 41.69 | 0.14 | 41.83 | 54 | -12.17 | AVG |
| 7320.000 | 42.65 | 2.36 | 45.01 | 74 | -28.99 | peak |
| 7320.000 | 38.58 | 2.36 | 40.94 | 54 | -13.06 | AVG |
| | | | | | | |
| | | | | | | |

Remark:
Factor = Antenna Factor + Cable Loss – Pre-amplifier.

| | | | |
|--------------------|-------------------------|--------------------------|----------------|
| EUT | Soundcore Liberty 2 Pro | Model Name | A3909R |
| Temperature | 25° C | Relative Humidity | 55.4% |
| Pressure | 960hPa | Test Voltage | Normal Voltage |
| Test Mode | Mode 2 | Antenna | Vertical |

| Frequency (MHz) | Meter Reading (dBμV) | Factor (dB) | Emission Level (dBμV/m) | Limits (dBμV/m) | Margin (dB) | Value Type |
|-----------------|----------------------|-------------|-------------------------|-----------------|-------------|------------|
| 4880.000 | 44.67 | 0.14 | 44.81 | 74 | -29.19 | peak |
| 4880.000 | 40.61 | 0.14 | 40.75 | 54 | -13.25 | AVG |
| 7320.000 | 41.75 | 2.36 | 44.11 | 74 | -29.89 | peak |
| 7320.000 | 37.43 | 2.36 | 39.79 | 54 | -14.21 | AVG |
| | | | | | | |
| | | | | | | |

Remark:
Factor = Antenna Factor + Cable Loss – Pre-amplifier.



| | | | |
|--------------------|-------------------------|--------------------------|----------------|
| EUT | Soundcore Liberty 2 Pro | Model Name | A3909R |
| Temperature | 25° C | Relative Humidity | 55.4% |
| Pressure | 960hPa | Test Voltage | Normal Voltage |
| Test Mode | Mode 3 | Antenna | Horizontal |

| Frequency (MHz) | Meter Reading (dBμV) | Factor (dB) | Emission Level (dBμV/m) | Limits (dBμV/m) | Margin (dB) | Value Type |
|-----------------|----------------------|-------------|-------------------------|-----------------|-------------|------------|
| 4960.000 | 44.43 | 0.22 | 44.65 | 74 | -29.35 | peak |
| 4960.000 | 40.34 | 0.22 | 40.56 | 54 | -13.44 | AVG |
| 7440.000 | 39.92 | 2.64 | 42.56 | 74 | -31.44 | peak |
| 7440.000 | 37.63 | 2.64 | 40.27 | 54 | -13.73 | AVG |
| | | | | | | |
| | | | | | | |

Remark:
Factor = Antenna Factor + Cable Loss – Pre-amplifier.

| | | | |
|--------------------|-------------------------|--------------------------|----------------|
| EUT | Soundcore Liberty 2 Pro | Model Name | A3909R |
| Temperature | 25° C | Relative Humidity | 55.4% |
| Pressure | 960hPa | Test Voltage | Normal Voltage |
| Test Mode | Mode 3 | Antenna | Vertical |

| Frequency (MHz) | Meter Reading (dBμV) | Factor (dB) | Emission Level (dBμV/m) | Limits (dBμV/m) | Margin (dB) | Value Type |
|-----------------|----------------------|-------------|-------------------------|-----------------|-------------|------------|
| 4960.000 | 43.71 | 0.22 | 43.93 | 74 | -30.07 | peak |
| 4960.000 | 39.62 | 0.22 | 39.84 | 54 | -14.16 | AVG |
| 7440.000 | 38.55 | 2.64 | 41.19 | 74 | -32.81 | peak |
| 7440.000 | 36.74 | 2.64 | 39.38 | 54 | -14.62 | AVG |
| | | | | | | |
| | | | | | | |

Remark:
Factor = Antenna Factor + Cable Loss – Pre-amplifier.

RESULT: PASS

Note: Other emissions from 1G to 25 GHz are considered as ambient noise. No recording in the test report.

Factor = Antenna Factor + Cable loss - Amplifier gain, Over=Measure-Limit.

The “Factor” value can be calculated automatically by software of measurement system.



TEST RESULT FOR RESTRICTED BANDS REQUIREMENTS

| | | | |
|-------------|-------------------------|-------------------|----------------|
| EUT | Soundcore Liberty 2 Pro | Model Name | A3909R |
| Temperature | 25° C | Relative Humidity | 55.4% |
| Pressure | 960hPa | Test Voltage | Normal Voltage |
| Test Mode | Mode 1 | Antenna | Horizontal |

PK

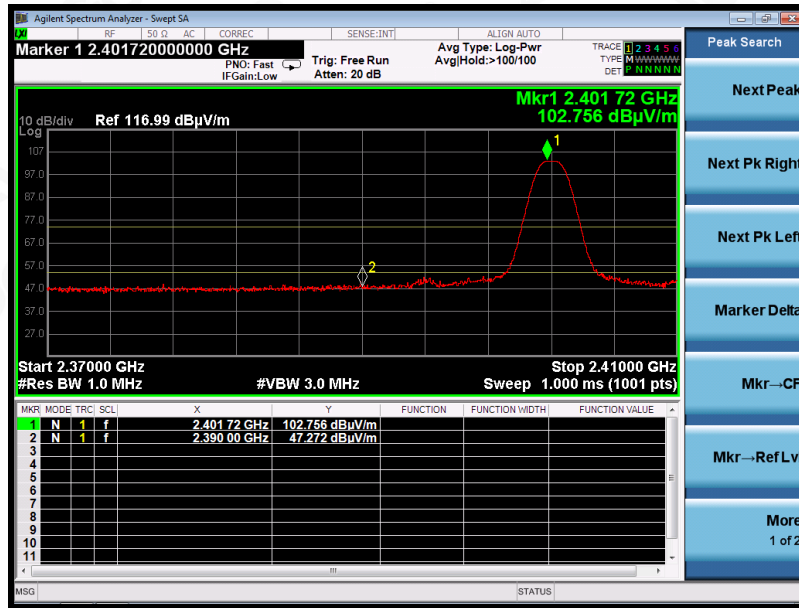

AV

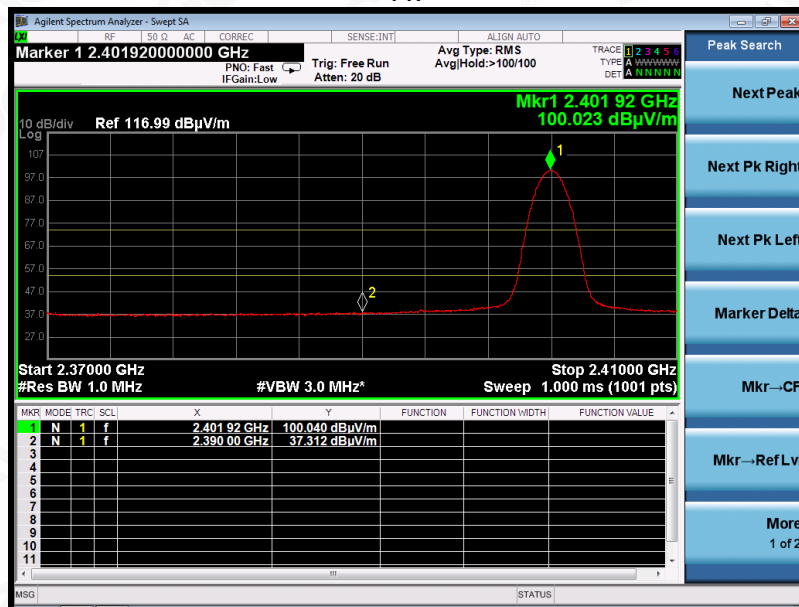

RESULT: PASS



Attestation of Global Compliance

Attestation of Global Compliance(Shenzhen)Co.,Ltd.
Add: 2/F., Building 2, Sanwei Chaxi Industrial Park, Sanwei Community,
Hangcheng Street, Bao'an District, Shenzhen, Guangdong, China
Tel: +86-755 2523 4088 E-mail: agc@agc-cert.com Service Hotline:400 089 2118

| | | | |
|-------------|-------------------------|-------------------|----------------|
| EUT | Soundcore Liberty 2 Pro | Model Name | A3909R |
| Temperature | 25° C | Relative Humidity | 55.4% |
| Pressure | 960hPa | Test Voltage | Normal Voltage |
| Test Mode | Mode 1 | Antenna | Vertical |

PK

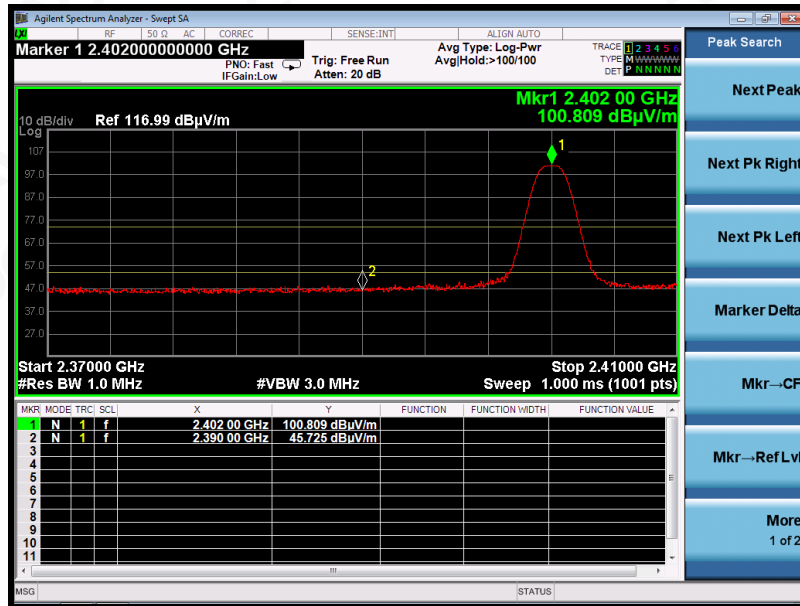

AV

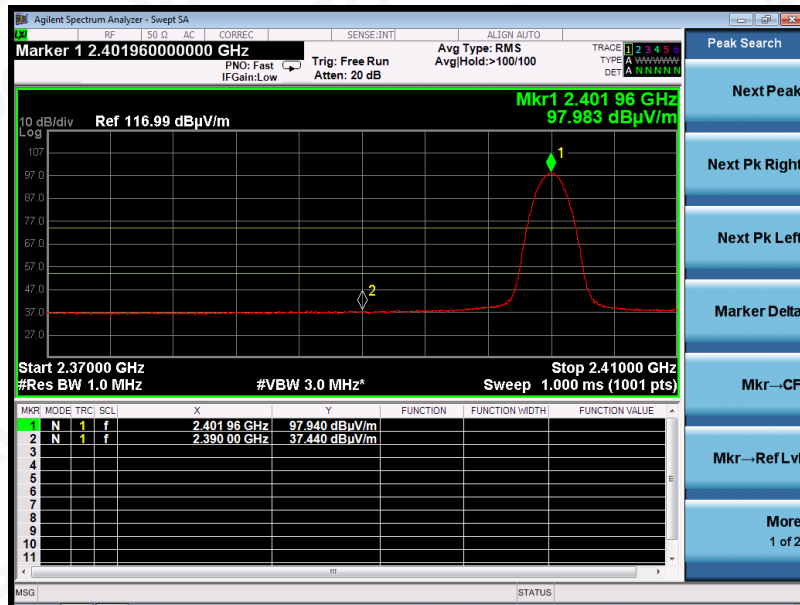

RESULT: PASS



Attestation of Global Compliance

Attestation of Global Compliance(Shenzhen)Co.,Ltd.

Add: 2/F., Building 2, Sanwei Chaxi Industrial Park, Sanwei Community,
Hangcheng Street, Bao'an District, Shenzhen, Guangdong, China

Tel: +86-755 2523 4088

E-mail: agc@agc-cert.com

Service Hotline: 400 089 2118

| | | | |
|-------------|-------------------------|-------------------|----------------|
| EUT | Soundcore Liberty 2 Pro | Model Name | A3909R |
| Temperature | 25° C | Relative Humidity | 55.4% |
| Pressure | 960hPa | Test Voltage | Normal Voltage |
| Test Mode | Mode 3 | Antenna | Horizontal |

PK

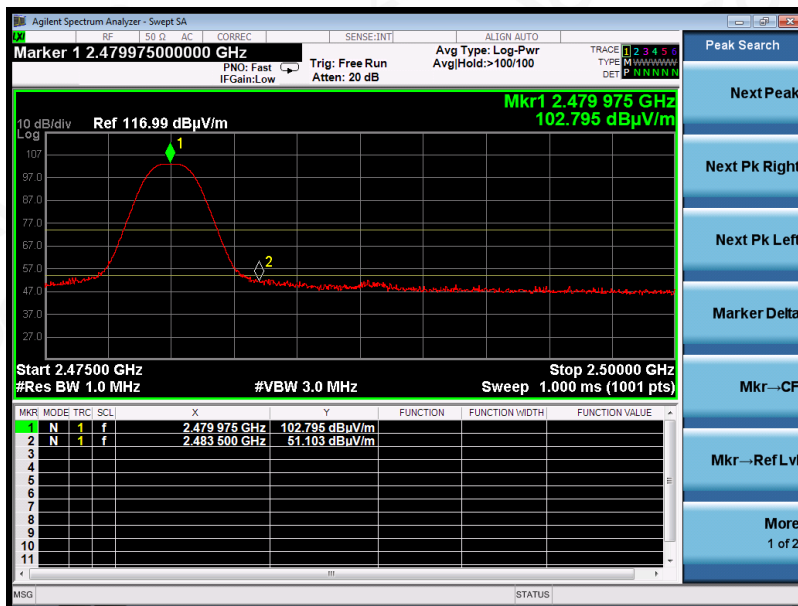

AV

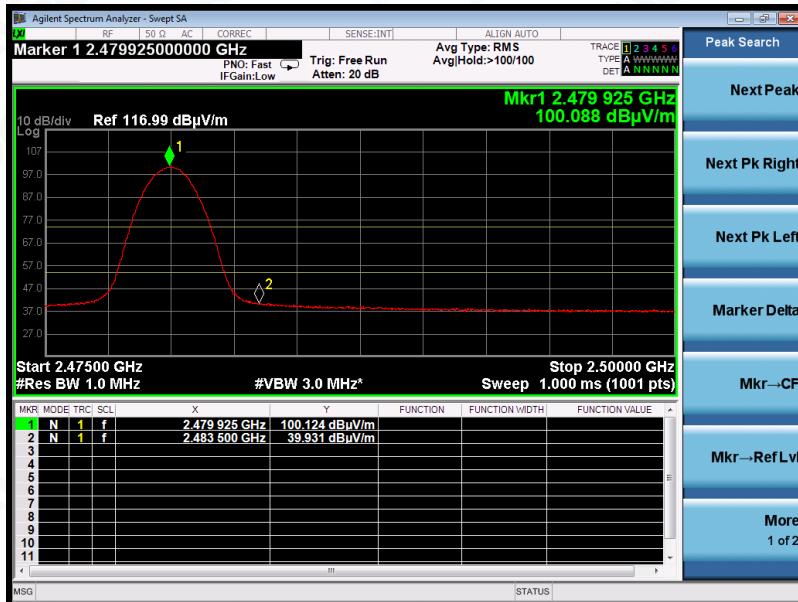

RESULT: PASS



Attestation of Global Compliance

Attestation of Global Compliance(Shenzhen)Co.,Ltd.
Add: 2/F., Building 2, Sanwei Chaxi Industrial Park, Sanwei Community,
Hangcheng Street, Bao'an District, Shenzhen, Guangdong, China
Tel: +86-755 2523 4088 E-mail: agc@agc-cert.com Service Hotline:400 089 2118

| | | | |
|-------------|-------------------------|-------------------|----------------|
| EUT | Soundcore Liberty 2 Pro | Model Name | A3909R |
| Temperature | 25° C | Relative Humidity | 55.4% |
| Pressure | 960hPa | Test Voltage | Normal Voltage |
| Test Mode | Mode 3 | Antenna | Vertical |

PK

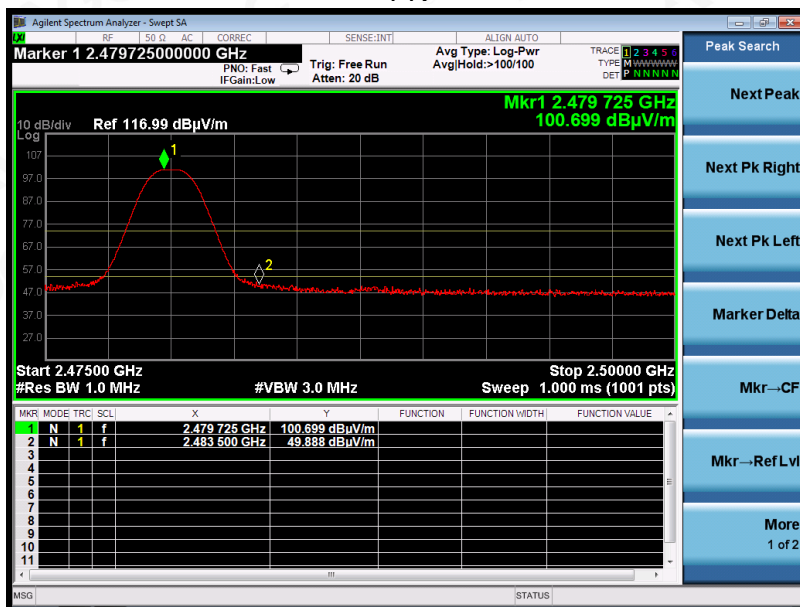

AV

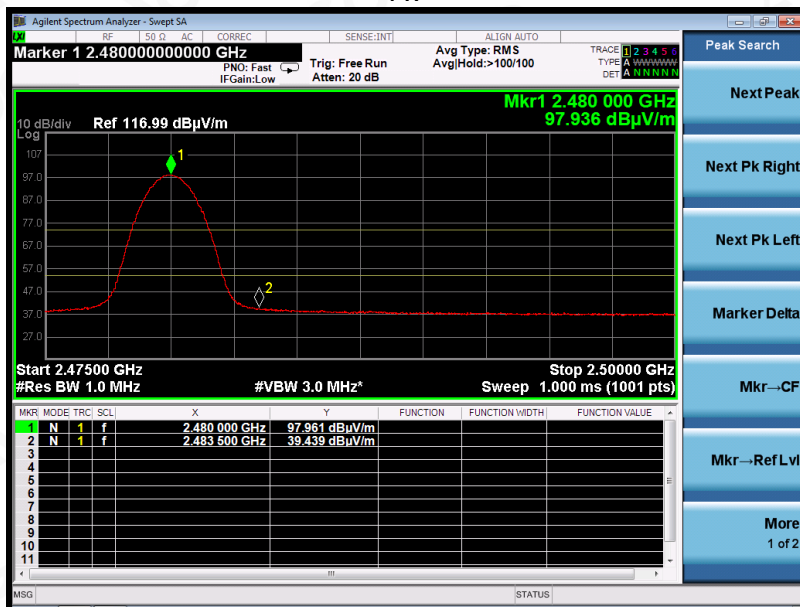

RESULT: PASS

Note: The factor had been edited in the “Input Correction” of the Spectrum Analyzer. So the Amplitude of test plots is equal to Reading level plus the Factor in dB. Use the A dB(μV) to represent the Amplitude. Use the F dB(μV/m) to represent the Field Strength. So A=F.



Attestation of Global Compliance

Attestation of Global Compliance(Shenzhen)Co.,Ltd.
Add: 2/F., Building 2, Sanwei Chaxi Industrial Park, Sanwei Community,
Hangcheng Street, Bao'an District, Shenzhen, Guangdong, China
Tel: +86-755 2523 4088 E-mail: agc@agc-cert.com Service Hotline:400 089 2118

12. FCC LINE CONDUCTED EMISSION TEST

12.1. LIMITS OF LINE CONDUCTED EMISSION TEST

| Frequency | Maximum RF Line Voltage | |
|---------------|-------------------------|----------------|
| | Q.P.(dBuV) | Average(dBuV) |
| 150kHz~500kHz | 66-56 | 56-46 |
| 500kHz~5MHz | 56 | 46 |
| 5MHz~30MHz | 60 | 50 |

Note: 1. The lower limit shall apply at the transition frequency.

2. The limit decreases linearly with the logarithm of the frequency in the range 0.15 MHz to 0.50 MHz.

12.2. BLOCK DIAGRAM OF LINE CONDUCTED EMISSION TEST

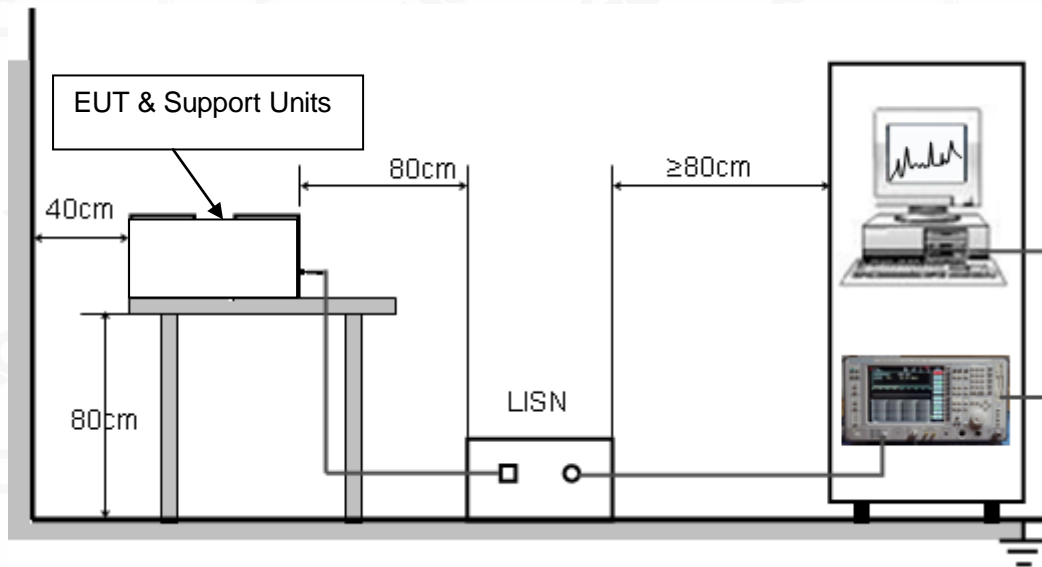

12.3. PRELIMINARY PROCEDURE OF LINE CONDUCTED EMISSION TEST

1. The equipment was set up as per the test configuration to simulate typical actual usage per the user's manual. When the EUT is a tabletop system, a wooden table with a height of 0.8 meters is used and is placed on the ground plane as per ANSI C63.10 (see Test Facility for the dimensions of the ground plane used). When the EUT is a floor-standing equipment, it is placed on the ground plane which has a 3-12 mm non-conductive covering to insulate the EUT from the ground plane.
2. Support equipment, if needed, was placed as per ANSI C63.10.
3. All I/O cables were positioned to simulate typical actual usage as per ANSI C63.10.
4. All support equipments received AC120V/60Hz power from a LISN, if any.
5. The EUT received DC charging voltage by PC which received AC120V/60Hz power by a LISN..
6. The test program was started. Emissions were measured on each current carrying line of the EUT using a spectrum Analyzer / Receiver connected to the LISN powering the EUT. The LISN has two monitoring points: Line 1 (Hot Side) and Line 2 (Neutral Side). Two scans were taken: one with Line 1 connected to Analyzer / Receiver and Line 2 connected to a 50 ohm load; the second scan had Line 1 connected to a 50 ohm load and Line 2 connected to the Analyzer / Receiver.
7. Analyzer / Receiver scanned from 150 kHz to 30MHz for emissions in each of the test modes.
8. During the above scans, the emissions were maximized by cable manipulation.
9. The test mode(s) were scanned during the preliminary test.

Then, the EUT configuration and cable configuration of the above highest emission level were recorded for reference of final testing.

12.4. FINAL PROCEDURE OF LINE CONDUCTED EMISSION TEST

1. EUT and support equipment was set up on the test bench as per step 2 of the preliminary test.
2. A scan was taken on both power lines, Line 1 and Line 2, recording at least the six highest emissions. Emission frequency and amplitude were recorded into a computer in which correction factors were used to calculate the emission level and compare reading to the applicable limit. If EUT emission level was less -2dB to the A.V. limit in Peak mode, then the emission signal was re-checked using Q.P and Average detector.
3. The test data of the worst case condition(s) was reported on the Summary Data page.

12.5. TEST RESULT OF LINE CONDUCTED EMISSION TEST

N/A

Note: The EUT can not use the BT function with charging.

APPENDIX A: PHOTOGRAPHS OF TEST SETUP

Refer to Attached file(appendix I)

APPENDIX B: PHOTOGRAPHS OF EUT

Refer to Attached file(appendix I)

----END OF REPORT----

