

We have RF equipments as below

Anechoic Chambe

- Satimo 1ea
- SY24 1ea
- SAR 1ea
- KSS 2ea

Measurement

- 2G, 3G, 4G
- GPS
- Wifi
- Bluetooth(3.0) OTA
- NFC & WPC

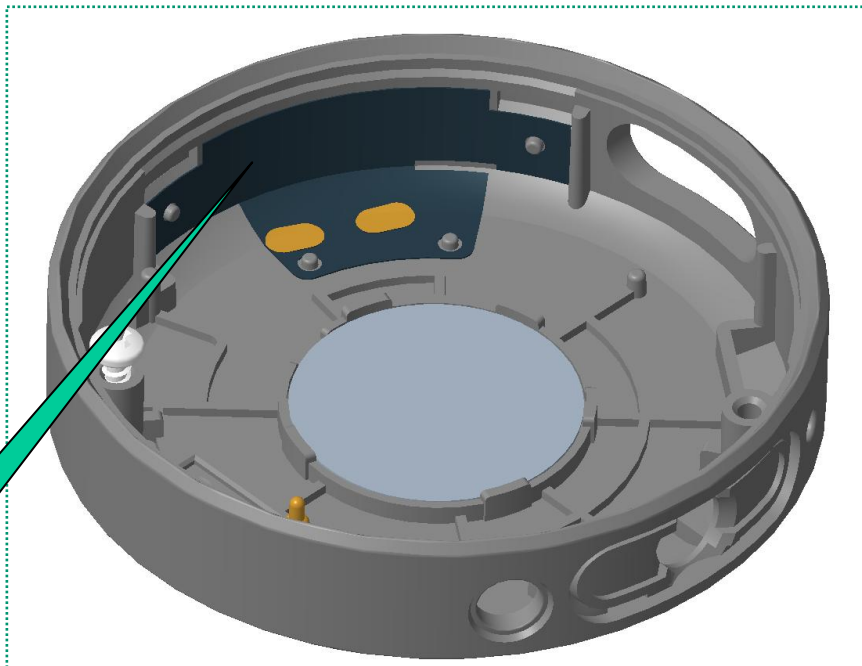

TX-2-ANT

Customer	Anker	Written By	LNF	Orig. Date	2022.11.16
part Number	ATC1339-HY044B02RA	Revised By	SHIN	Revised Date	2022.11.16
Description	TX-2 ANT	Approved By	HJ	Approved Date	2022.11.16

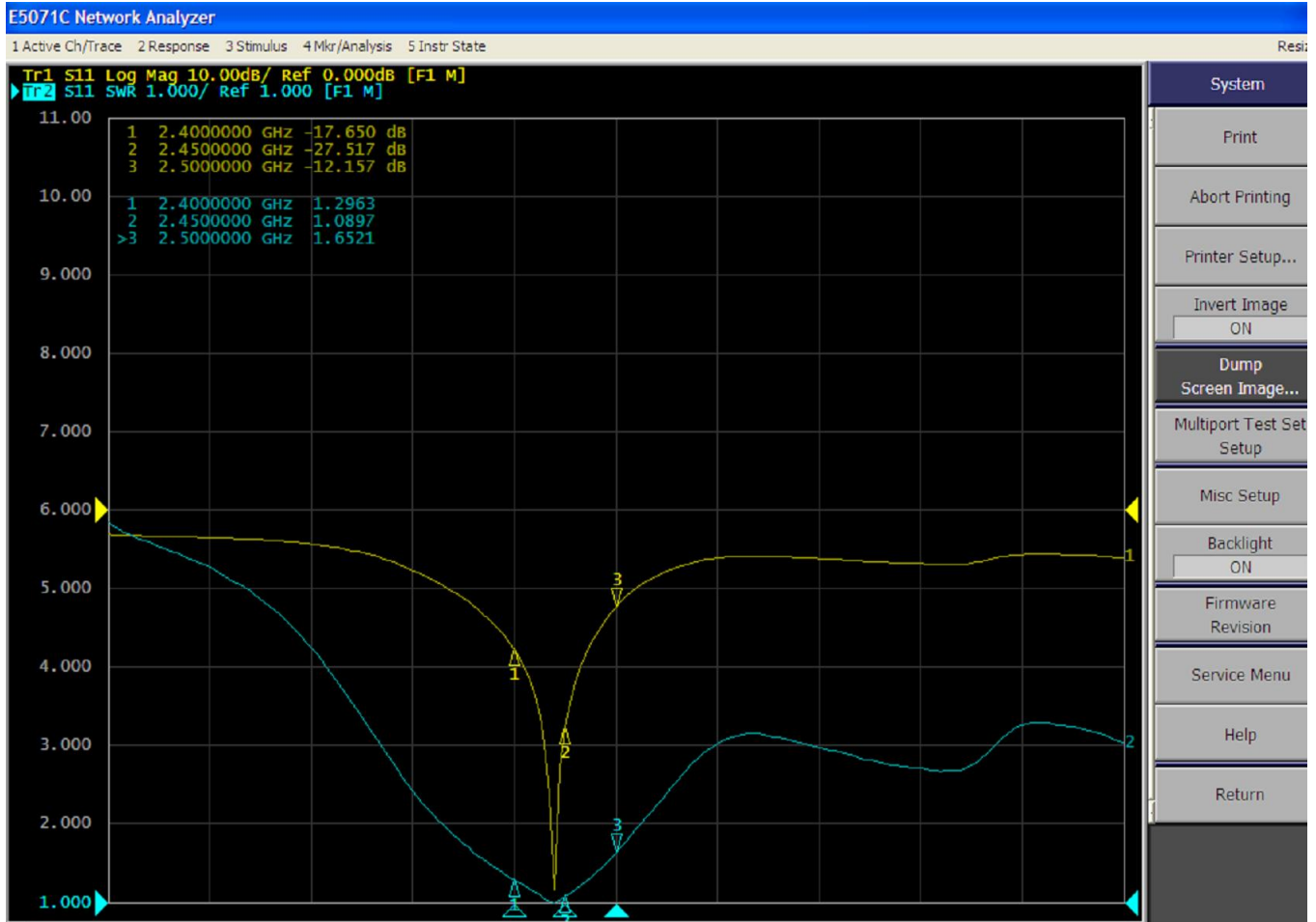



TX-2 Antenna *Efficiency

Customer	Anker	Written By	LNF	Orig. Date	2022.11.16
part Number	ATC1339-HY044B02RA	Revised By	SHIN	Revised Date	2022.11.16
Description	TX-2 ANT	Approved By	HJ	Approved Date	2022.11.16

Frequency	Efficiency/%	Gain. dB
2400	57%	2.87
2410	59%	2.97
2420	60%	3.13
2430	61%	3.17
2440	62%	3.17
2450	62%	3.18
2460	60%	3.12
2470	60%	3.20
2480	63%	3.42
2490	66%	3.78
2500	65%	3.85



OTA TEST

Customer	Anker	Written By	LNF	Orig. Date	2022.11.16
part Number	ATC1339-HY044B02RA	Revised By	SHIN	Revised Date	2022.11.16
Description	TX-2 ANT	Approved By	HJ	Approved Date	2022.11.16

BT-LE	TRP	0	10.67
		19	10.59
		39	10.48
	TIS	0	-90.71
		19	-90.66
		39	-90.43

Customer	Anker	Written By	LNF	Orig. Date	2022.11.16
part Number	ATC1339-HY044B02RA	Revised By	SHIN	Revised Date	2022.11.16
Description	TX-2 ANT	Approved By	HJ	Approved Date	2022.11.16

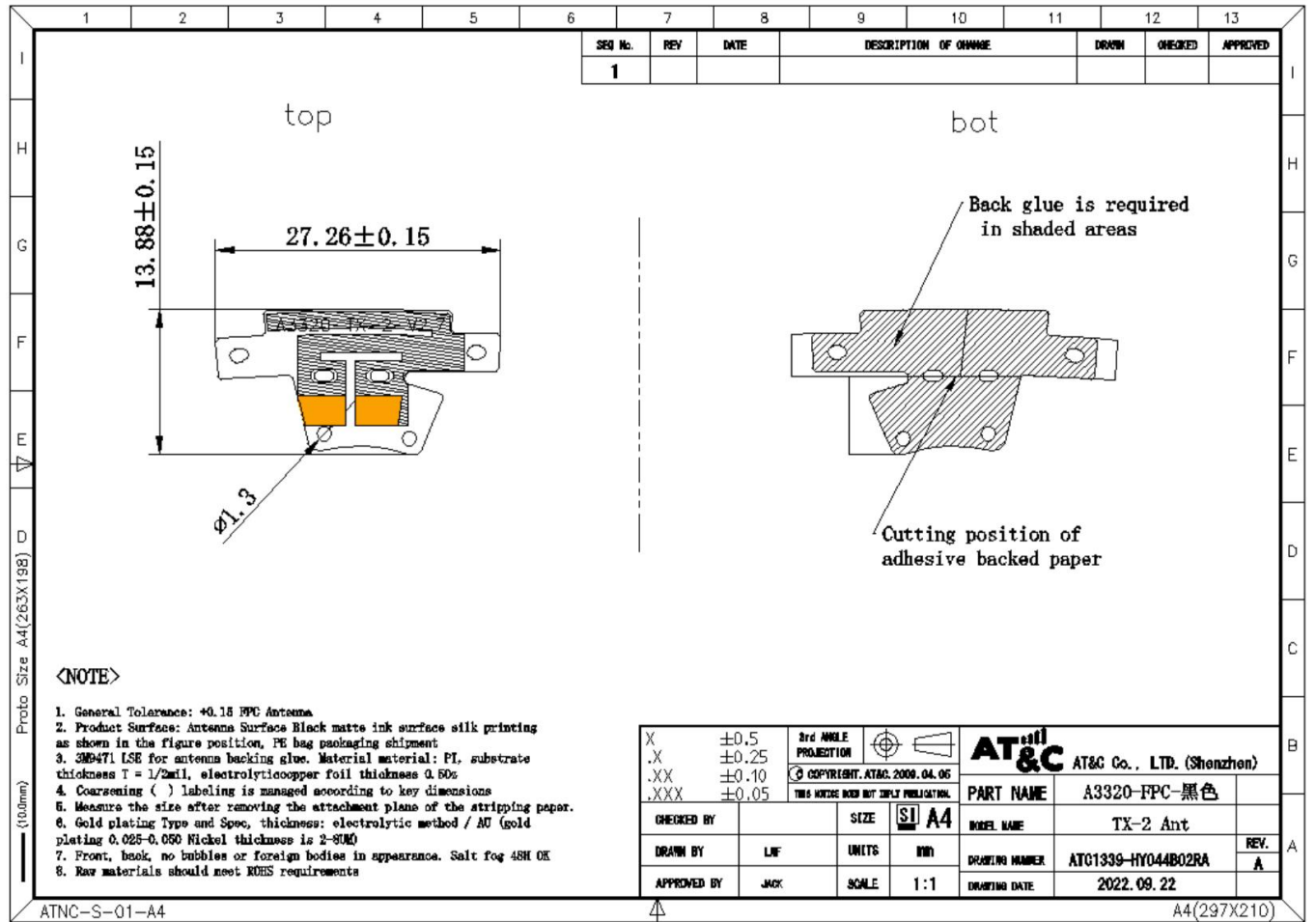

Size information					Measuring sample			% Tolerance		Handling opinions			Measuring tool
num ber	Dime nsion prop erty	Dimen sion	Lower to larence	Upper t oleranc e	1	2	3	Upper	Lower	determi ne	Supplier r eview co mments	Custo mer r eview co mments	
1	key p oint	27.26	-0.15	0.15	27.31	27.29	27.30			PASS			PJ
2	key p oint	13.88	-0.15	0.15	13.85	13.88	13.92			PASS			PJ
3	key p oint	1.3	-0.10	0.10	1.29	1.31	1.31			PASS			PJ