

FCC Test Report

Report No.: AGC01110180420FE04

FCC ID : 2AOKB-A3109
APPLICATION PURPOSE : Original Equipment
PRODUCT DESIGNATION : Soundcore Motion B
BRAND NAME : Soundcore
MODEL NAME : A3109
CLIENT : Anker Innovations Limited
DATE OF ISSUE : May 07, 2018
STANDARD(S) : FCC Part 15 Subpart C Section 15.247
REPORT VERSION : V1.0

Attestation of Global Compliance (Shenzhen) Co., Ltd

CAUTION:

This report shall not be reproduced except in full without the written permission of the test laboratory and shall not be quoted out of context.



The results shown in this test report refer only to the sample(s) tested unless otherwise stated and the sample(s) are retained for 30 days only. The document is issued by AGC, this document cannot be reproduced except in full with our prior written permission. The more details and the authenticity of the report will be confirmed at <http://www.agc-cert.com>.

Report Revise Record

| Report Version | Revise Time | Issued Date | Valid Version | Notes |
|----------------|-------------|--------------|---------------|-----------------|
| V1.0 | / | May 07, 2018 | Valid | Initial release |

The results shown in this test report refer only to the sample(s) tested unless otherwise stated and the sample(s) are retained for 30 days only. The document is issued by AGC, this document cannot be reproduced except in full with our prior written permission. The more details and the authenticity of the report will be confirmed at <http://www.agc-cert.com>.

TABLE OF CONTENTS

1. VERIFICATION OF CONFORMITY 5

2. GENERAL INFORMATION 6

2.1. PRODUCT DESCRIPTION 6

2.2. TABLE OF CARRIER FREQUENCIES 6

2.3. RECEIVER INPUT BANDWIDTH 7

2.4. EXAMPLE OF A HOPPING SEQUENCY IN DATA MODE 7

2.5. EQUALLY AVERAGE USE OF FREQUENCIES AND BEHAVIOUR 7

2.6. TEST METHOD 8

2.7. EQUIPMENT MODIFICATIONS 8

3. MEASUREMENT UNCERTAINTY 9

4. DESCRIPTION OF TEST MODES 10

5. SYSTEM TEST CONFIGURATION 11

5.1. CONFIGURATION OF EUT SYSTEM 11

5.2. EQUIPMENT USED IN EUT SYSTEM 11

5.3. SUMMARY OF TEST RESULTS 12

6. TEST FACILITY 13

7. TEST EQUIPMENT LIST 14

8. PEAK OUTPUT POWER 15

8.1. MEASUREMENT PROCEDURE 15

8.2. TEST SET-UP (BLOCK DIAGRAM OF CONFIGURATION) 15

8.3. LIMITS AND MEASUREMENT RESULT 16

9. BANDWIDTH 22

9.1. MEASUREMENT PROCEDURE 22

9.2. TEST SET-UP (BLOCK DIAGRAM OF CONFIGURATION) 22

9.3. LIMITS AND MEASUREMENT RESULTS 22

10. CONDUCTED SPURIOUS EMISSION 29

10.1. MEASUREMENT PROCEDURE 29

10.2. TEST SET-UP (BLOCK DIAGRAM OF CONFIGURATION) 29

10.3. LIMITS AND MEASUREMENT RESULT 29

11. RADIATED EMISSION 33

11.1. TEST LIMIT 33

11.2. MEASUREMENT PROCEDURE 33

11.3. TEST SETUP 35

11.4. TEST RESULT 37

12. BAND EDGE EMISSION 50

12.1. MEASUREMENT PROCEDURE 50

The results shown in this test report refer only to the sample(s) tested unless otherwise stated and the sample(s) are retained for 30 days only. The document is issued by AGC, this document cannot be reproduced except in full with our prior written permission. The more details and the authenticity of the report will be confirmed at <http://www.agc-cert.com>.

| | |
|---|-----------|
| 12.2. TEST SET-UP | 50 |
| 12.3. TEST RESULT | 51 |
| 13. NUMBER OF HOPPING FREQUENCY | 55 |
| 13.1. MEASUREMENT PROCEDURE | 55 |
| 13.2. TEST SETUP (BLOCK DIAGRAM OF CONFIGURATION) | 55 |
| 13.3. LIMITS AND MEASUREMENT RESULT | 55 |
| 14. TIME OF OCCUPANCY (DWELL TIME) | 57 |
| 14.1. MEASUREMENT PROCEDURE | 57 |
| 14.2. TEST SETUP (BLOCK DIAGRAM OF CONFIGURATION) | 57 |
| 14.3. LIMITS AND MEASUREMENT RESULT | 57 |
| 15. FREQUENCY SEPARATION..... | 60 |
| 15.1. MEASUREMENT PROCEDURE | 60 |
| 15.2. TEST SETUP (BLOCK DIAGRAM OF CONFIGURATION) | 60 |
| 15.3. LIMITS AND MEASUREMENT RESULT | 60 |
| 16. LINE CONDUCTED EMISSION TEST | 62 |
| 16.1. LIMITS OF LINE CONDUCTED EMISSION TEST | 62 |
| 16.2. BLOCK DIAGRAM OF LINE CONDUCTED EMISSION TEST | 62 |
| 16.3. PRELIMINARY PROCEDURE OF LINE CONDUCTED EMISSION TEST | 63 |
| 16.4. FINAL PROCEDURE OF LINE CONDUCTED EMISSION TEST | 63 |
| 16.5. TEST RESULT OF LINE CONDUCTED EMISSION TEST | 64 |
| APPENDIX A: PHOTOGRAPHS OF TEST SETUP | 66 |
| APPENDIX B: PHOTOGRAPHS OF EUT..... | 69 |

The results shown in this test report refer only to the sample(s) tested unless otherwise stated and the sample(s) are retained for 30 days only. The document is issued by AGC, this document cannot be reproduced except in full with our prior written permission. The more details and the authenticity of the report will be confirmed at <http://www.agc-cert.com>.

1. VERIFICATION OF CONFORMITY

| | |
|---------------------------------|--|
| Applicant | Anker Innovations Limited |
| Address | Room 1318-19, Hollywood Plaza, 610 Nathan Road, Mongkok, Kowloon, Hongkong |
| Manufacturer | Anker Innovations Limited |
| Address | Room 1318-19, Hollywood Plaza, 610 Nathan Road, Mongkok, Kowloon, Hongkong |
| Product Designation | Soundcore Motion B |
| Brand Name | Soundcore |
| Test Model | A3109 |
| Date of test | Apr. 22, 2018 to May 04, 2018 |
| Deviation | None |
| Condition of Test Sample | Normal |
| Report Template | AGCRT-US-BR/RF (2013-03-01) |

We hereby certify that:

The above equipment was tested by Attestation of Global Compliance (Shenzhen) Co., Ltd. The test data, the energy emitted by the sample tested as described in this report is in compliance with the requirements of FCC Rules Part 15.247. The test results of this report relate only to the tested sample identified in this report.

Tested By



Henry Zhang(Zhang Zhuorui) May 04, 2018

Reviewed By



Cool Cheng(Cheng Mengguo) May 07, 2018

Approved By



Forrest Lei(Lei Yonggang)
 Authorized Officer May 07, 2018

The results shown in this test report refer only to the sample(s) tested unless otherwise stated and the sample(s) are retained for 30 days only. The document is issued by AGC, this document cannot be reproduced except in full with our prior written permission. The more details and the authenticity of the report will be confirmed at <http://www.agc-cert.com>.

2. GENERAL INFORMATION

2.1. PRODUCT DESCRIPTION

The EUT is "Soundcore Motion B" designed as a "Communication Device". It is designed by way of utilizing the FHSS technology to achieve the system operation.

A major technical description of EUT is described as following

| | |
|----------------------------|-----------------------------|
| Operation Frequency | 2.402 GHz to 2.480GHz |
| RF Output Power | 2.54dBm(Max) |
| Bluetooth Version | V4.2 |
| Modulation | GFSK, $\pi/4$ -DQPSK, 8DPSK |
| Number of channels | 79 |
| Hardware Version | V0.3 |
| Software Version | V2.9 |
| Antenna Designation | Fixed Antenna |
| Antenna Gain | 3dBi |
| Power Supply | DC 3.7V by battery |

Note:

1. The EUT didn't support BLE.
2. The USB port only used for charging and can't be used to transfer data with PC.

2.2. TABLE OF CARRIER FREQUENCIES

| Frequency Band | Channel Number | Frequency |
|----------------|----------------|-----------|
| 2402~2480MHz | 0 | 2402MHz |
| | 1 | 2403MHz |
| | : | : |
| | 38 | 2440 MHz |
| | 39 | 2441 MHz |
| | 40 | 2442 MHz |
| | : | : |
| | 77 | 2479 MHz |
| | 78 | 2480 MHz |

The results shown in this test report refer only to the sample(s) tested unless otherwise stated and the sample(s) are retained for 30 days only. The document is issued by AGC, this document cannot be reproduced except in full with our prior written permission. The more details and the authenticity of the report will be confirmed at <http://www.agc-cert.com>.

2.3. RECEIVER INPUT BANDWIDTH

The input bandwidth of the receiver is 1.3MHz. In every connection one Bluetooth device is the master and the other one is slave. The master determines the hopping sequence. The slave follows this sequence. Both devices shift between RX and TX time slot according to the clock of the master. Additionally the type of connection (e.g. single or multislotted packet) is set up at the beginning of the connection. The master adapts its hopping frequency and its TX/RX timing according to the packet type of the connection. Also the slave of the connection will use these settings.

Repeating of a packet has no influence on the hopping sequence. The hopping sequence generated by the master of the connection will be followed in any case. That means, a repeated packet will not be sent on the same frequency, it is sent on the next frequency of the hopping sequence.

2.4. EXAMPLE OF A HOPPING SEQUENCE IN DATA MODE

Example of a 79 hopping sequence in data mode:

40,21,44,23,42,53,46,55,48,33,52,35,50,65,54,67
56,37,60,39,58,69,62,71,64,25,68,27,66,57,70,59
72,29,76,31,74,61,78,63,01,41,05,43,03,73,07,75
09,45,13,47,11,77,15,00,64,49,66,53,68,02,70,06
01, 51, 03, 55, 05, 04

2.5. EQUALLY AVERAGE USE OF FREQUENCIES AND BEHAVIOUR

The generation of the hopping sequence in connection mode depends essentially on two input values:

1. LAP/UAP of the master of the connection.
2. Internal master clock

The LAP (lower address part) are the 24 LSB's of the 48 BD_ADDRESS. The BD_ADDRESS is an unambiguous number of every Bluetooth unit. The UAP (upper address part) are the 24 MSB's of the 48 BD_ADDRESS.

The internal clock of a Bluetooth unit is derived from a free running clock which is never adjusted and is never turned off. For synchronization with other units only offsets are used. It has no relation to the time of the day. Its resolution is at least half the RX/TX slot length of 312.5µs. The clock has a cycle of about one day (23h30). In most cases it is implemented as a 28-bit counter. For the deriving of the hopping sequence the entire LAP (24 bits), 4 LSB's (4 bits) (Input 1) and the 27 MSB's of the clock (Input 2) are used. With these input values different mathematical procedures (permutations, additions, XOR-operations) are performed to generate the Sequence.

This will be done at the beginning of every new transmission.

Regarding short transmissions the Bluetooth system has the following behavior:

The first connection between the two devices is established, a hopping sequence was generated. For transmitting the wanted data the complete hopping sequence was not used. The connection ended.

The second connection will be established. A new hopping sequence is generated. Due to the fact the Bluetooth clock has a different value, because the period between the two transmissions is longer (and it cannot be shorter) than the minimum resolution of the clock (312.5µs). The hopping sequence will always differ from the first one.

2.6. TEST METHOD

All measurements contained in this report were conducted with ANSI C63.10-2013.

2.7. EQUIPMENT MODIFICATIONS

Not available for this EUT intended for grant.

The results shown in this test report refer only to the sample(s) tested unless otherwise stated and the sample(s) are retained for 30 days only. The document is issued by AGC, this document cannot be reproduced except in full with our prior written permission. The more details and the authenticity of the report will be confirmed at <http://www.agc-cert.com>.

3. MEASUREMENT UNCERTAINTY

The reported uncertainty of measurement $y \pm U$, where expanded uncertainty U is based on a standard uncertainty multiplied by a coverage factor of $k=2$, providing a level of confidence of approximately 95 %

- Uncertainty of Conducted Emission, $U_c = \pm 3.2$ dB
- Uncertainty of Radiated Emission below 1GHz, $U_c = \pm 3.9$ dB
- Uncertainty of Radiated Emission above 1GHz, $U_c = \pm 4.8$ dB

The results shown in this test report refer only to the sample(s) tested unless otherwise stated and the sample(s) are retained for 30 days only. The document is issued by AGC, this document cannot be reproduced except in full with our prior written permission. The more details and the authenticity of the report will be confirmed at <http://www.agc-cert.com>.

4. DESCRIPTION OF TEST MODES

| NO. | TEST MODE DESCRIPTION |
|-----|-------------------------------|
| 1 | Low channel GFSK |
| 2 | Middle channel GFSK |
| 3 | High channel GFSK |
| 4 | Low channel $\pi/4$ -DQPSK |
| 5 | Middle channel $\pi/4$ -DQPSK |
| 6 | High channel $\pi/4$ -DQPSK |
| 7 | Low channel 8DPSK |
| 8 | Middle channel 8DPSK |
| 9 | High channel 8DPSK |
| 10 | BT Link with charging |
| 11 | BT Link |

Note:

1. All the test modes can be supply by battery, only the result of the worst case was recorded in the report, if no other cases.
2. For Radiated Emission, 3axis were chosen for testing for each applicable mode.
3. The EUT used fully-charged battery when tested.

Software Setting

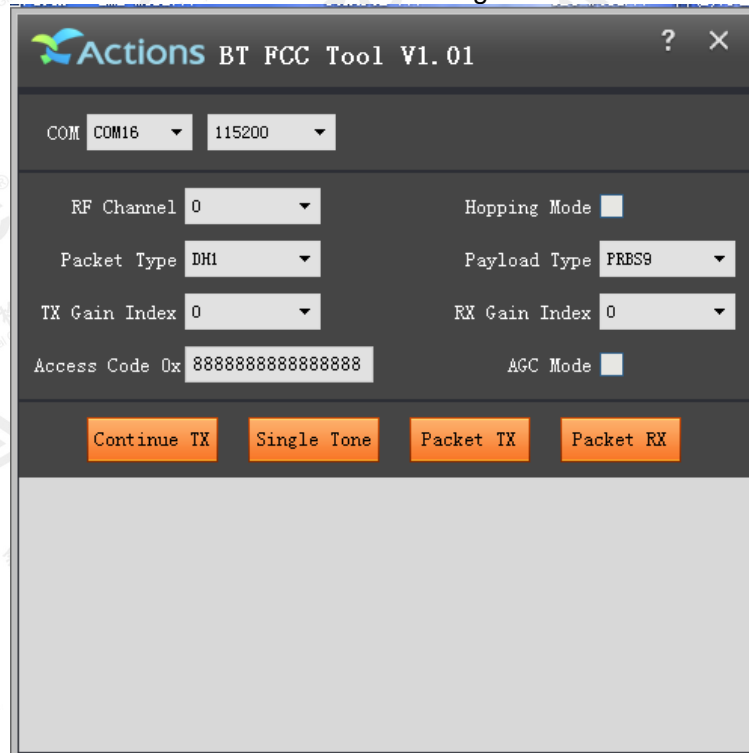

The results shown in this test report refer only to the sample(s) tested unless otherwise stated and the sample(s) are retained for 30 days only. The document is issued by AGC, this document cannot be reproduced except in full with our prior written permission. The more details and the authenticity of the report will be confirmed at <http://www.agc-cert.com>.

5. SYSTEM TEST CONFIGURATION

5.1. CONFIGURATION OF EUT SYSTEM

Configure 1: (Normal hopping)

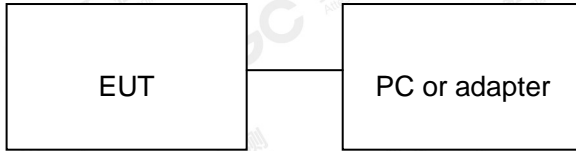

Note: Owing to the EUT has own battery, and testing may be performed while PC or adapter removed.

Configure 2: (Control continuous TX)

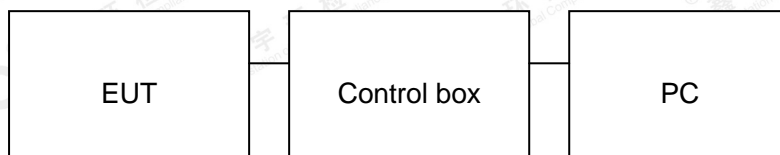

5.2. EQUIPMENT USED IN EUT SYSTEM

| Item | Equipment | Mfr/Brand | Model/Type No. | Remark |
|------|--------------------|----------------|------------------|-----------|
| 1 | Soundcore Motion B | Soundcore | A3109 | EUT |
| 2 | Battery | Giantsun Power | PA18 | Accessory |
| 3 | PC | APPLE | A1465 | A.E |
| 4 | Control box | SERIAL | N/A | A.E |
| 5 | Adapter | N/A | MX12X8-0502000UU | A.E |
| 6 | AUX IN Cable | N/A | 1m Unshielded | A.E |
| 7 | USB Cable | N/A | 0.6m Unshielded | Accessory |
| 8 | USB Cable | N/A | 1m Unshielded | A.E |
| 9 | IPOD | APPLE | A1367 | A.E |
| 10 | Temporary Antenna | T10 | N/A | A.E |

The results shown in this test report refer only to the sample(s) tested unless otherwise stated and the sample(s) are retained for 30 days only. The document is issued by AGC, this document cannot be reproduced except in full with our prior written permission. The more details and the authenticity of the report will be confirmed at <http://www.agc-cert.com>.

5.3. SUMMARY OF TEST RESULTS

| FCC RULES | DESCRIPTION OF TEST | RESULT |
|----------------------|-----------------------------|-----------|
| §15.247 b(1) | Peak Output Power | Compliant |
| §15.247 a(1) | 20 dB Bandwidth | Compliant |
| §15.247 d | Conducted Spurious Emission | Compliant |
| §15.247 d §15.209 | Radiated Emission | Compliant |
| §15.247 d | Band Edges | Compliant |
| §15.247 a(1)(iii) | Number of hopping frequency | Compliant |
| §15.247 a(1)(iii) | Time of Occupancy | Compliant |
| §15.247 a(1) | Frequency Separation | Compliant |
| §15.207 | Line conduction Emission | Compliant |

The results shown in this test report refer only to the sample(s) tested unless otherwise stated and the sample(s) are retained for 30 days only. The document is issued by AGC, this document cannot be reproduced except in full with our prior written permission. The more details and the authenticity of the report will be confirmed at <http://www.agc-cert.com>.

6. TEST FACILITY

| | |
|--------------------------------------|--|
| Test Site | Attestation of Global Compliance (Shenzhen) Co., Ltd |
| Location | 1-2F., Bldg.2, No.1-4, Chaxi Sanwei Technical Industrial Park, Gushu, Xixiang, Bao'an District B112-B113, Bldg.12, Baoan Bldg Materials Center, No.1 of Xixiang Inner Ring Road, Baoan District, Shenzhen 518012 |
| NVLAP Lab Code | 600153-0 |
| Designation Number | CN5028 |
| Test Firm Registration Number | 682566 |
| Description | Attestation of Global Compliance(Shenzhen) Co., Ltd is accredited by National Voluntary Laboratory Accreditation program, NVLAP Code 600153-0 |

The results shown in this test report refer only to the sample(s) tested unless otherwise stated and the sample(s) are retained for 30 days only. The document is issued by AGC, this document cannot be reproduced except in full with our prior written permission. The more details and the authenticity of the report will be confirmed at <http://www.agc-cert.com>.

7. TEST EQUIPMENT LIST

TEST EQUIPMENT OF CONDUCTED EMISSION TEST

| Equipment | Manufacturer | Model | S/N | Cal. Date | Cal. Due |
|---------------|--------------|---------|--------|--------------|--------------|
| TEST RECEIVER | R&S | ESPI | 101206 | Jun.20, 2017 | Jun.19, 2018 |
| LISN | R&S | ESH2-Z5 | 100086 | Aug.21, 2017 | Aug.20, 2018 |

TEST EQUIPMENT OF RADIATED EMISSION TEST

| Equipment | Manufacturer | Model | S/N | Cal. Date | Cal. Due |
|------------------------------|-----------------|-------------|------------|---------------|---------------|
| TEST RECEIVER | R&S | ESCI | 10096 | Jun.20, 2017 | Jun.19, 2018 |
| EXA Signal Analyzer | Aglient | N9010A | MY53470504 | Dec.08, 2017 | Dec.07, 2018 |
| Horn antenna | SCHWARZBECK | BBHA 9170 | #768 | Sep.20, 2017 | Sep.19, 2018 |
| preamplifier | ChengYi | EMC184045SE | 980508 | Sep.15, 2017 | Sep.14, 2018 |
| Double-Ridged Waveguide Horn | ETS LINDGREN | 3117 | 00034609 | May 18, 2017 | May 17, 2019 |
| Broadband Preamplifier | SCHWARZBECK | BBV 9718 | 9718-205 | Jun.20, 2017 | Jun.19, 2018 |
| ANTENNA | SCHWARZBECK | VULB9168 | D69250 | Sep.28, 2017 | Sep.27, 2018 |
| Radiation Cable 1 | MXT | RS1 | R005 | June 6, 2017 | June 5, 2018 |
| Radiation Cable 2 | MXT | RS1 | R006 | June 6, 2017 | June 5, 2018 |
| Loop Antenna | A.H.Systems,Inc | SAS-562B | -- | Mar. 01, 2018 | Feb. 28, 2019 |

The results shown in this test report refer only to the sample(s) tested unless otherwise stated and the sample(s) are retained for 30 days only. The document is issued by AGC, this document cannot be reproduced except in full with our prior written permission. The more details and the authenticity of the report will be confirmed at <http://www.agc-cert.com>.

8. PEAK OUTPUT POWER

8.1. MEASUREMENT PROCEDURE

For peak power test:

1. Connect EUT RF output port to the Spectrum Analyzer through an RF attenuator
2. Set the EUT Work on the top, middle and the bottom operation frequency individually.
3. $RBW >$ the 20 dB bandwidth of the emission being measured, $VBW \geq RBW$.
4. Record the maximum power from the Spectrum Analyzer.
5. The maximum peak power shall be less 21dBm.

8.2. TEST SET-UP (BLOCK DIAGRAM OF CONFIGURATION)

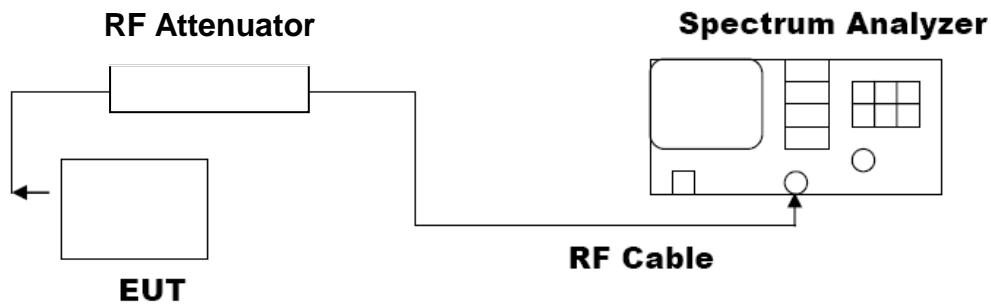

The results shown in this test report refer only to the sample(s) tested unless otherwise stated and the sample(s) are retained for 30 days only. The document is issued by AGC, this document cannot be reproduced except in full with our prior written permission. The more details and the authenticity of the report will be confirmed at <http://www.agc-cert.com>.

8.3. LIMITS AND MEASUREMENT RESULT

| PEAK OUTPUT POWER MEASUREMENT RESULT FOR GFSK MODULATION | | | |
|--|------------------|-------------------------|--------------|
| Frequency (GHz) | Peak Power (dBm) | Applicable Limits (dBm) | Pass or Fail |
| 2.402 | -3.31 | 21 | Pass |
| 2.441 | -1.94 | 21 | Pass |
| 2.480 | -0.73 | 21 | Pass |

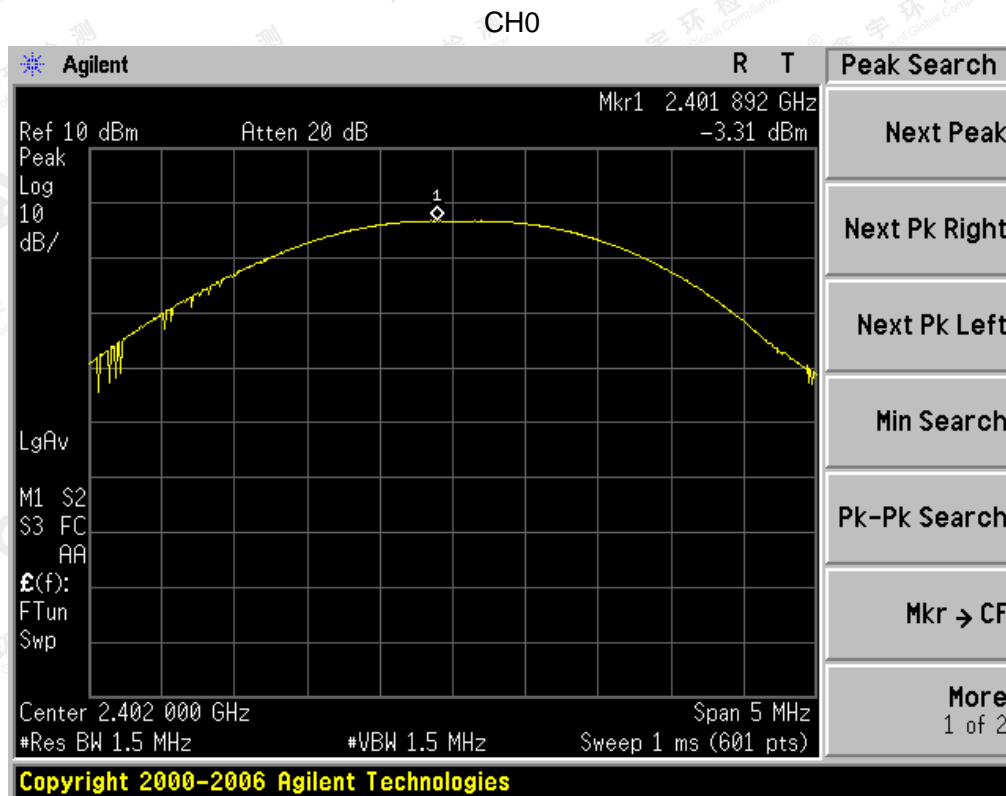

The results shown in this test report refer only to the sample(s) tested unless otherwise stated and the sample(s) are retained for 30 days only. The document is issued by AGC, this document cannot be reproduced except in full with our prior written permission. The more details and the authenticity of the report will be confirmed at <http://www.agc-cert.com>.

CH39

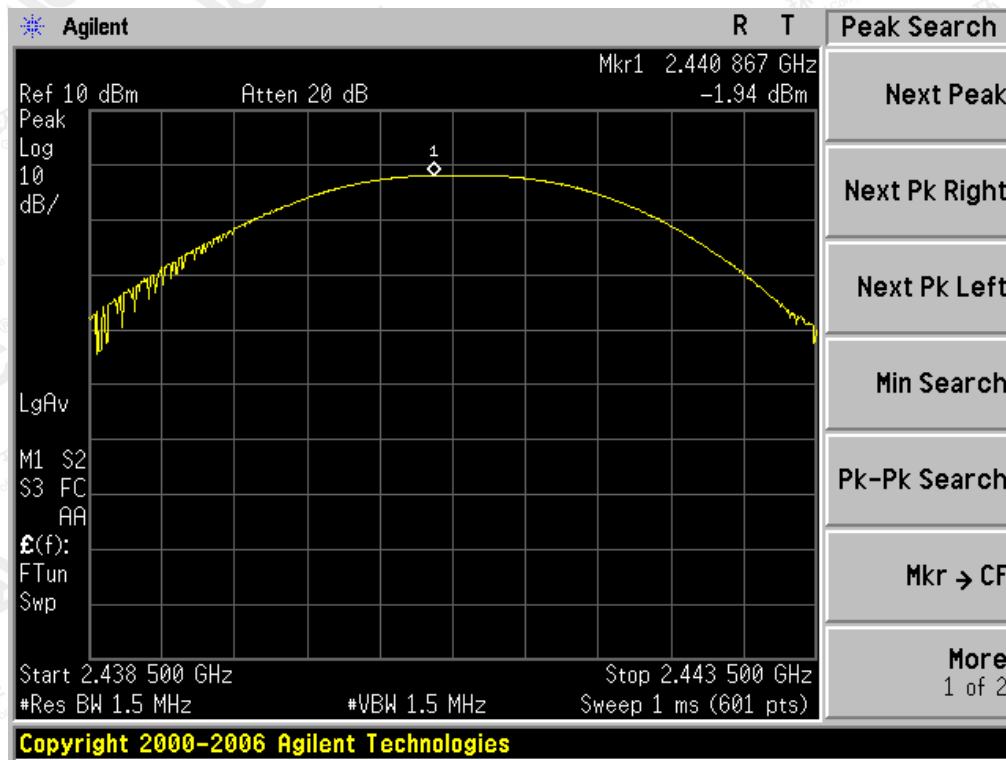

CH78

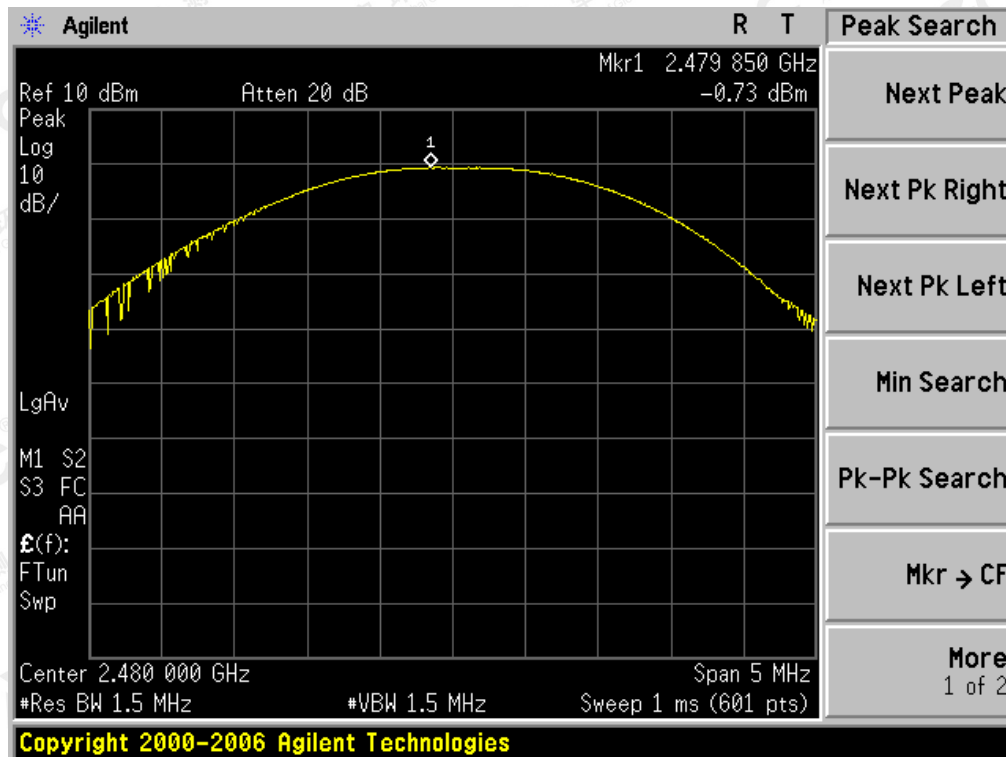

The results shown in this test report refer only to the sample(s) tested unless otherwise stated and the sample(s) are retained for 30 days only. The document is issued by AGC, this document cannot be reproduced except in full with our prior written permission. The more details and the authenticity of the report will be confirmed at <http://www.agc-cert.com>.

| PEAK OUTPUT POWER MEASUREMENT RESULT FOR Π /4-DQPSK MODULATION | | | |
|---|------------------|-------------------------|--------------|
| Frequency (GHz) | Peak Power (dBm) | Applicable Limits (dBm) | Pass or Fail |
| 2.402 | -0.59 | 21 | Pass |
| 2.441 | 0.62 | 21 | Pass |
| 2.480 | 2.12 | 21 | Pass |

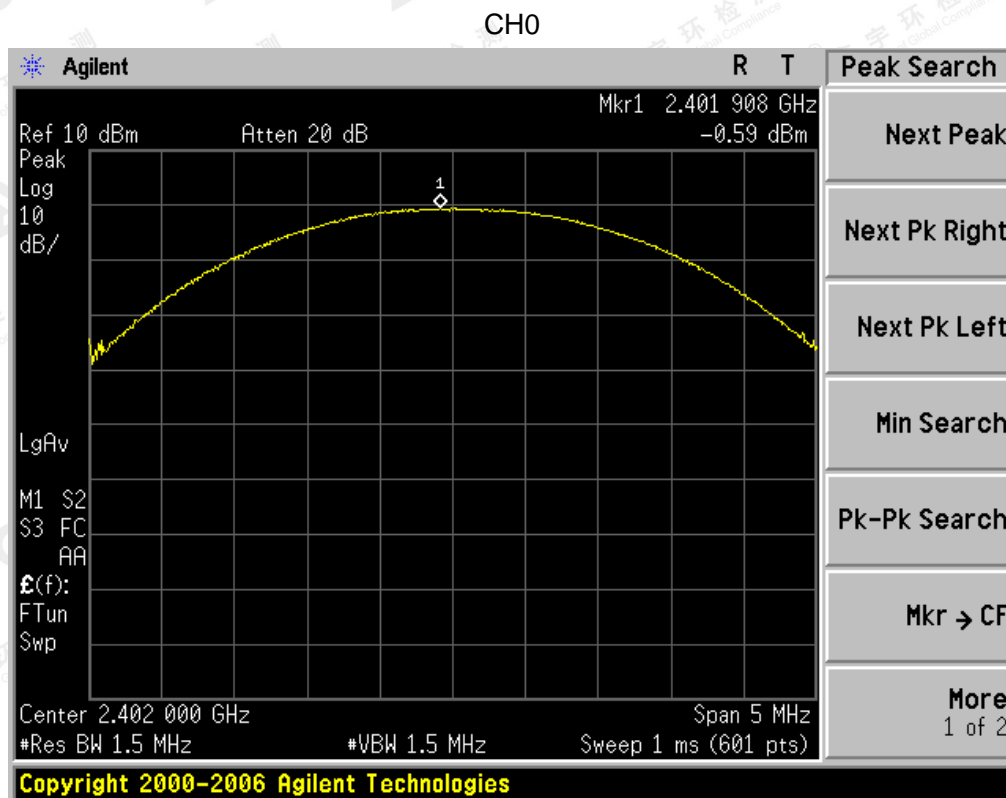

The results shown in this test report refer only to the sample(s) tested otherwise stated and the sample(s) are retained for 30 days only. The document is issued by AGC, this document cannot be reproduced except in full with our prior written permission. The more details and the authenticity of the report will be confirmed at <http://www.agc-cert.com>.

CH39

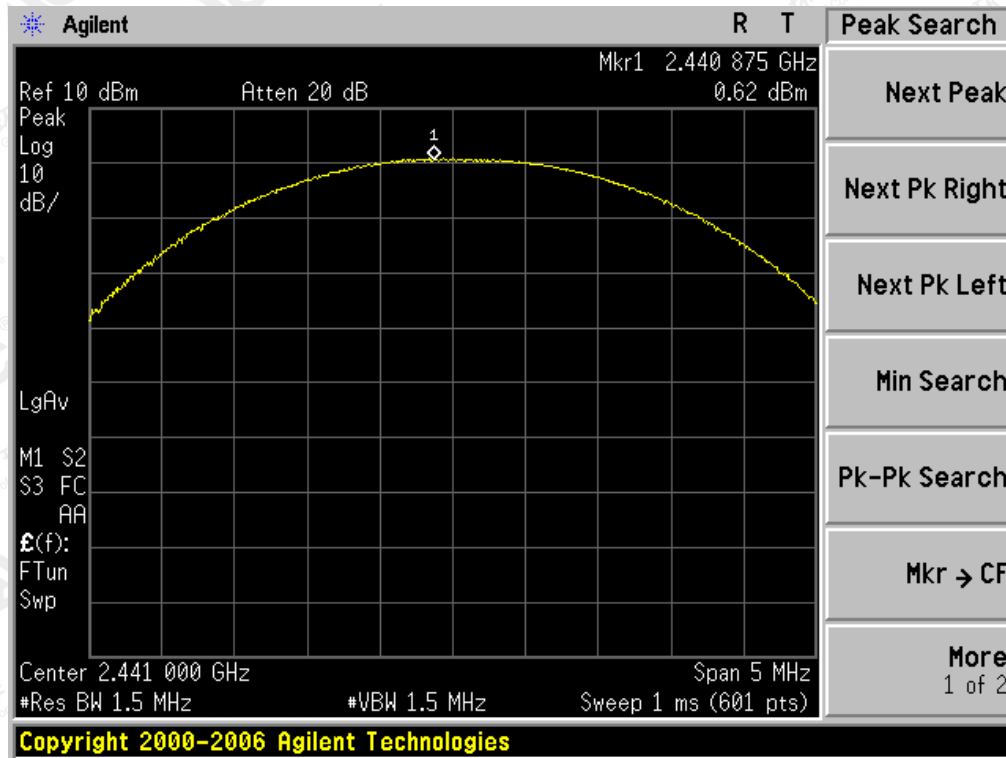

CH78

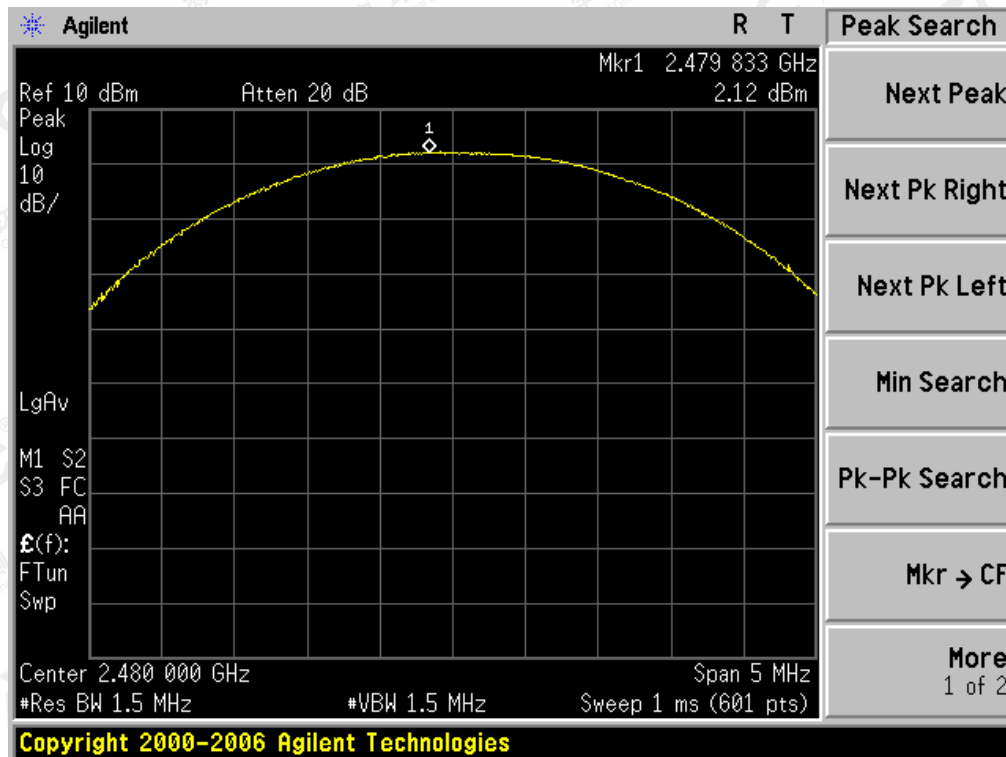

The results shown in this test report refer only to the sample(s) tested unless otherwise stated and the sample(s) are retained for 30 days only. The document is issued by AGC, this document cannot be reproduced except in full with our prior written permission. The more details and the authenticity of the report will be confirmed at <http://www.agc-cert.com>.

| PEAK OUTPUT POWER MEASUREMENT RESULT FOR 8DPSK MODULATION | | | |
|--|------------------|-------------------------|--------------|
| Frequency (GHz) | Peak Power (dBm) | Applicable Limits (dBm) | Pass or Fail |
| 2.402 | -0.26 | 21 | Pass |
| 2.441 | 1.09 | 21 | Pass |
| 2.480 | 2.54 | 21 | Pass |

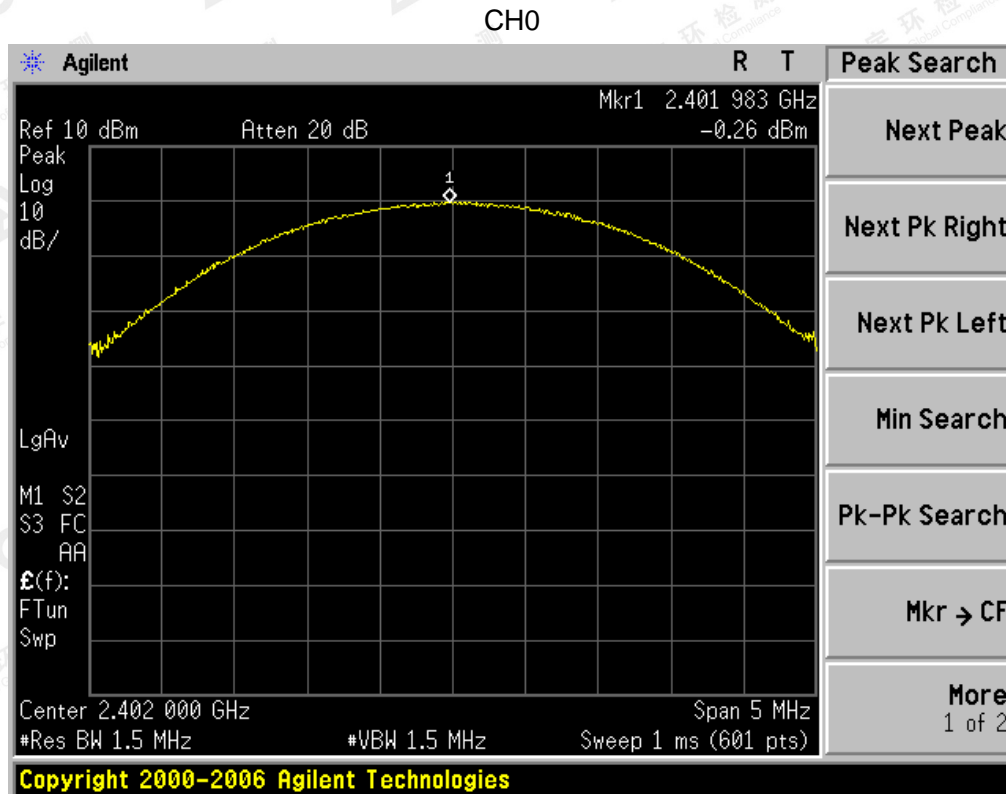

The results shown in this test report refer only to the sample(s) tested unless otherwise stated and the sample(s) are retained for 30 days only. The document is issued by AGC, this document cannot be reproduced except in full with our prior written permission. The more details and the authenticity of the report will be confirmed at <http://www.agc-cert.com>.

CH39

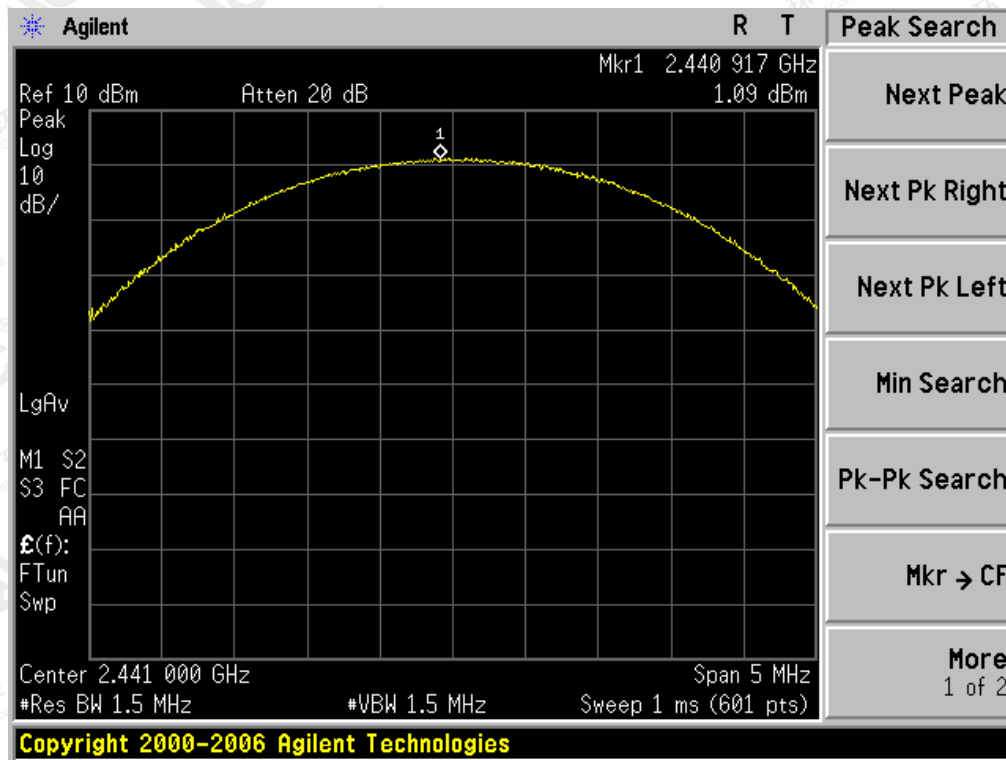

CH78

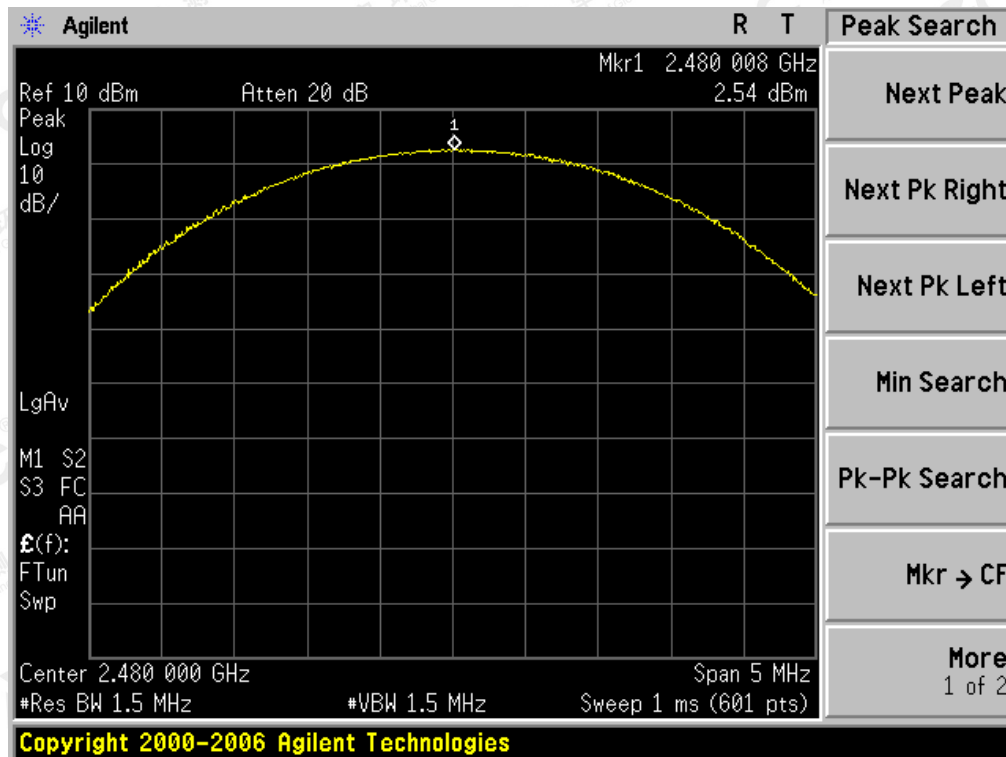

The results shown in this test report refer only to the sample(s) tested unless otherwise stated and the sample(s) are retained for 30 days only. The document is issued by AGC, this document cannot be reproduced except in full with our prior written permission. The more details and the authenticity of the report will be confirmed at <http://www.agc-cert.com>.

9. BANDWIDTH

9.1. MEASUREMENT PROCEDURE

1. Connect EUT RF output port to the Spectrum Analyzer through an RF attenuator
2. Set the EUT Work on the top, the middle and the bottom operation frequency individually.
3. Set Span = approximately 2 to 3 times the 20 dB bandwidth, centered on a hoping channel
RBW \geq 1% of the 20 dB bandwidth, VBW \geq 3RBW; Sweep = auto; Detector function = peak
4. Set SPA Trace 1 Max hold, then View.

9.2. TEST SET-UP (BLOCK DIAGRAM OF CONFIGURATION)

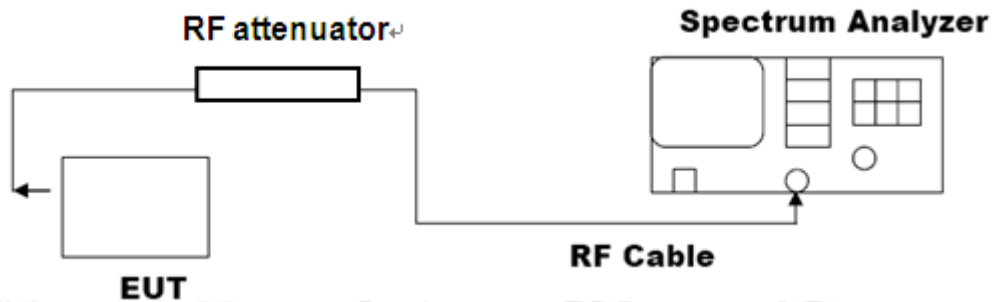

Note: The EUT has been used temporary antenna connector for testing.

9.3. LIMITS AND MEASUREMENT RESULTS

| BLUETOOTH 1MBPS LIMITS AND MEASUREMENT RESULT | | | | |
|---|--------------------|--------------|---------------|--------|
| Applicable Limits | Measurement Result | | | |
| | Test Data (MHz) | | | Result |
| | | 99%OBW (MHz) | -20dB BW(MHz) | |
| N/A | Low Channel | 0.938 | 1.072 | PASS |
| | Middle Channel | 0.941 | 1.077 | PASS |
| | High Channel | 0.931 | 1.070 | PASS |

The results shown in this test report refer only to the sample(s) tested unless otherwise stated and the sample(s) are retained for 30 days only. The document is issued by AGC, this document cannot be reproduced except in full with our prior written permission. The more details and the authenticity of the report will be confirmed at <http://www.agc-cert.com>.

TEST PLOT OF BANDWIDTH FOR LOW CHANNEL

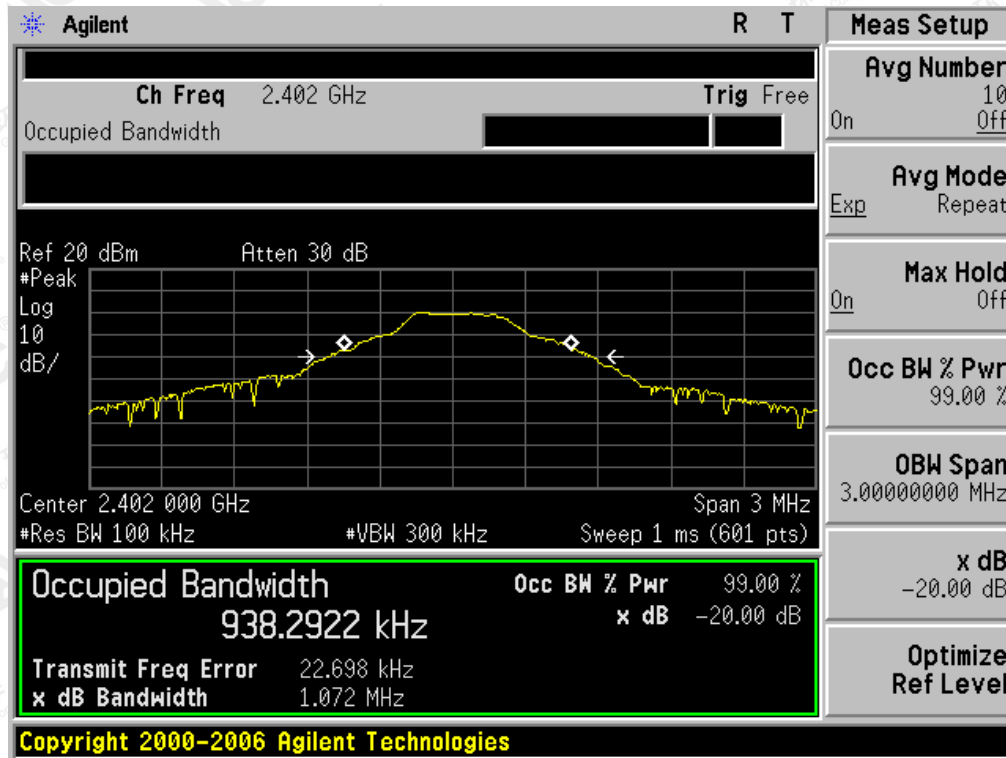

TEST PLOT OF BANDWIDTH FOR MIDDLE CHANNEL

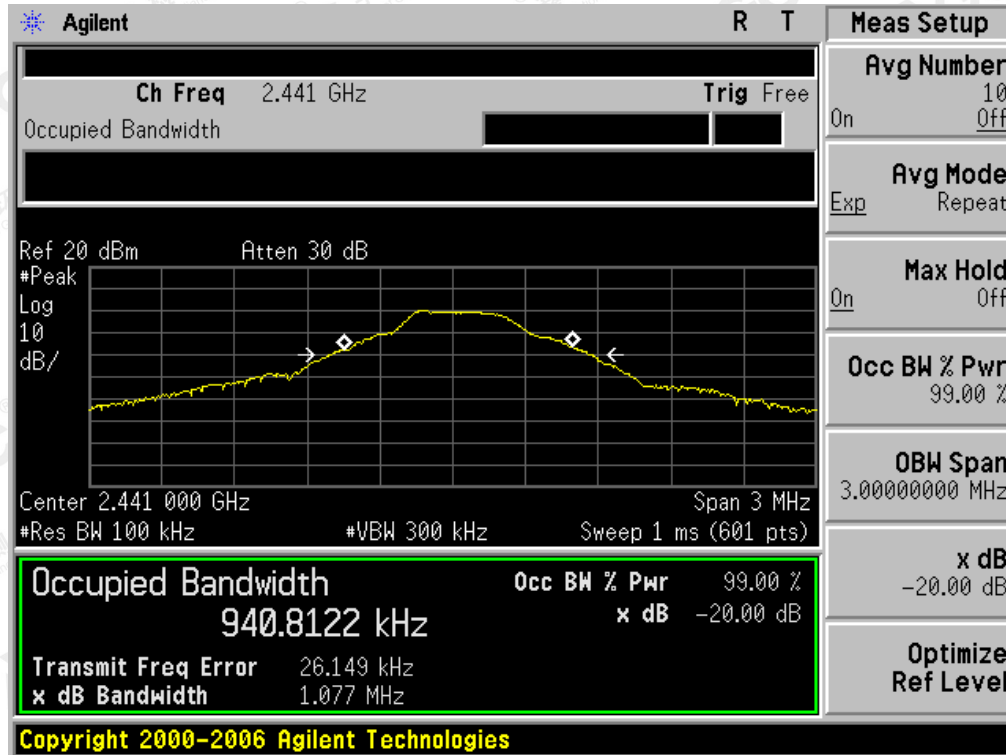

The results shown in this test report refer only to the sample(s) tested unless otherwise stated and the sample(s) are retained for 30 days only. The document is issued by AGC, this document cannot be reproduced except in full with our prior written permission. The more details and the authenticity of the report will be confirmed at <http://www.agc-cert.com>.

TEST PLOT OF BANDWIDTH FOR HIGH CHANNEL

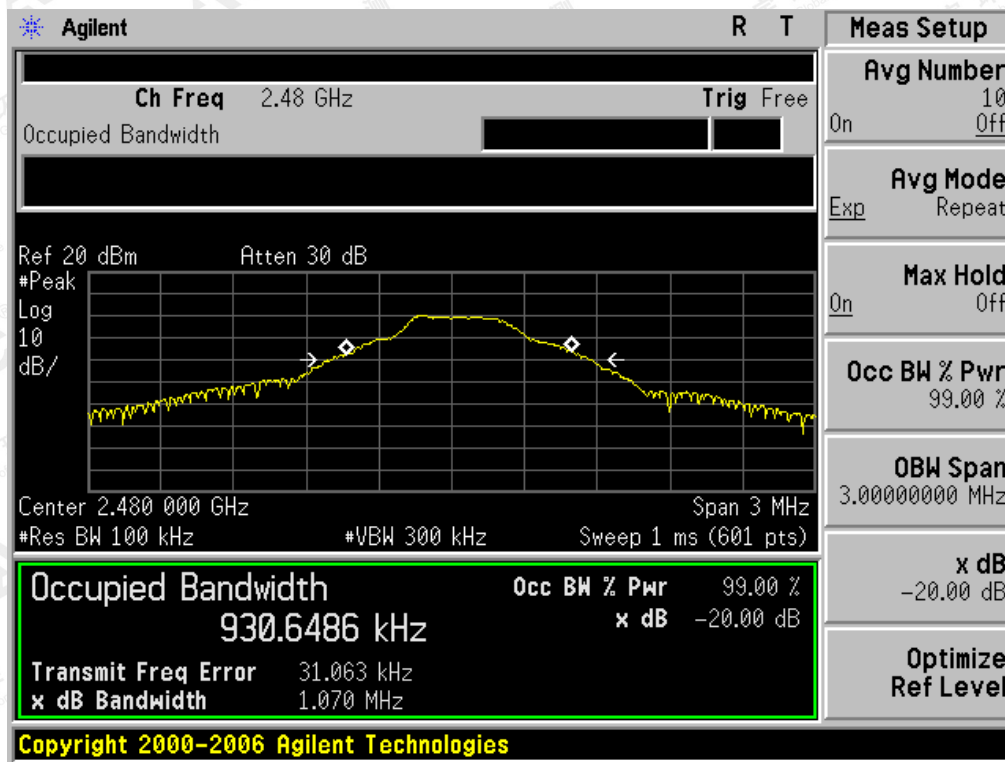

The results shown in this test report refer only to the sample(s) tested unless otherwise stated and the sample(s) are retained for 30 days only. The document is issued by AGC, this document cannot be reproduced except in full with our prior written permission. The more details and the authenticity of the report will be confirmed at <http://www.agc-cert.com>.

| BLUETOOTH 2MBPS LIMITS AND MEASUREMENT RESULT | | | | |
|---|--------------------|--------------|---------------|--------|
| Applicable Limits | Measurement Result | | | |
| | Test Data (MHz) | | | Result |
| | | 99%OBW (MHz) | -20dB BW(MHz) | |
| N/A | Low Channel | 1.225 | 1.388 | PASS |
| | Middle Channel | 1.226 | 1.398 | PASS |
| | High Channel | 1.225 | 1.390 | PASS |

TEST PLOT OF BANDWIDTH FOR LOW CHANNEL

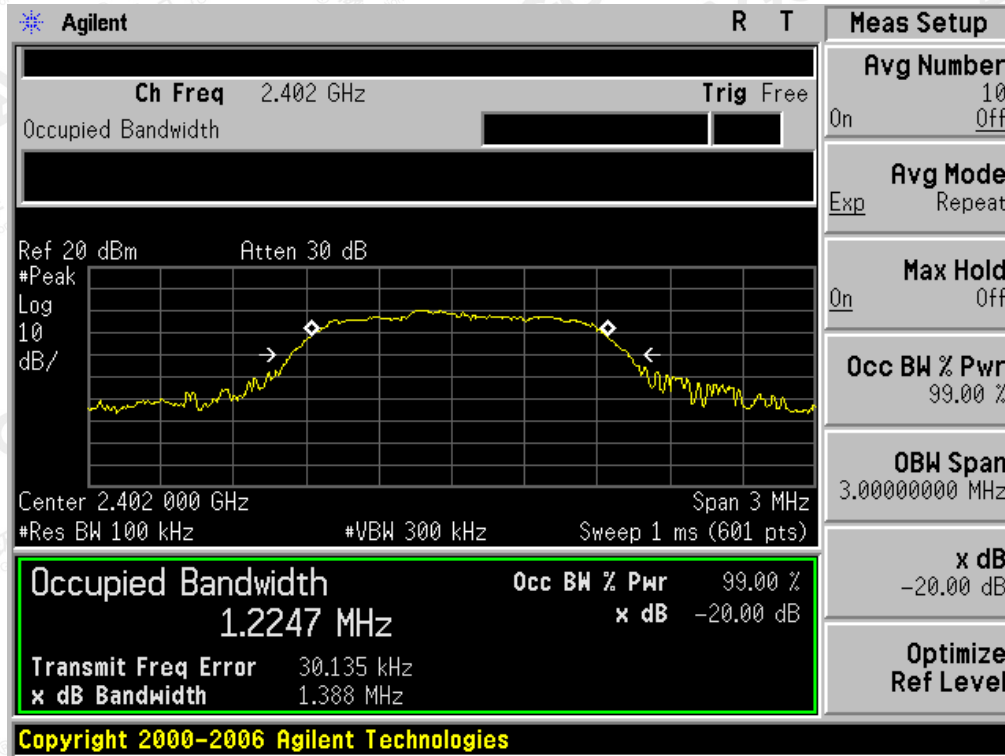

The results shown in this test report refer only to the sample(s) tested unless otherwise stated and the sample(s) are retained for 30 days only. The document is issued by AGC, this document cannot be reproduced except in full with our prior written permission. The more details and the authenticity of the report will be confirmed at <http://www.agc-cert.com>.

TEST PLOT OF BANDWIDTH FOR MIDDLE CHANNEL

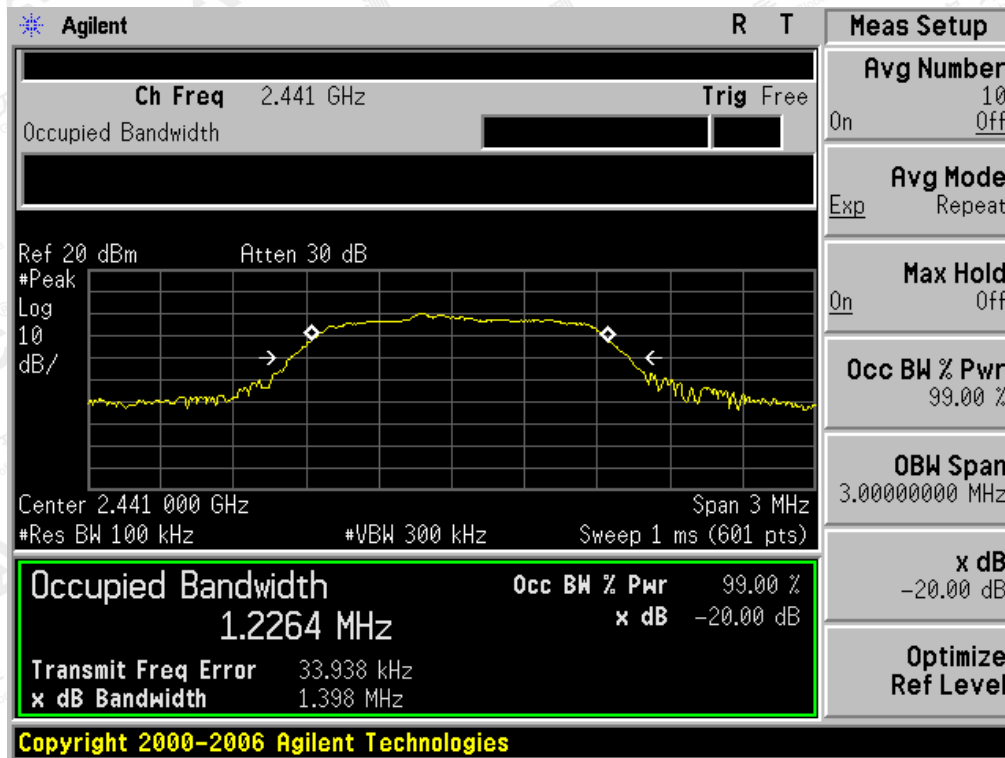

TEST PLOT OF BANDWIDTH FOR HIGH CHANNEL

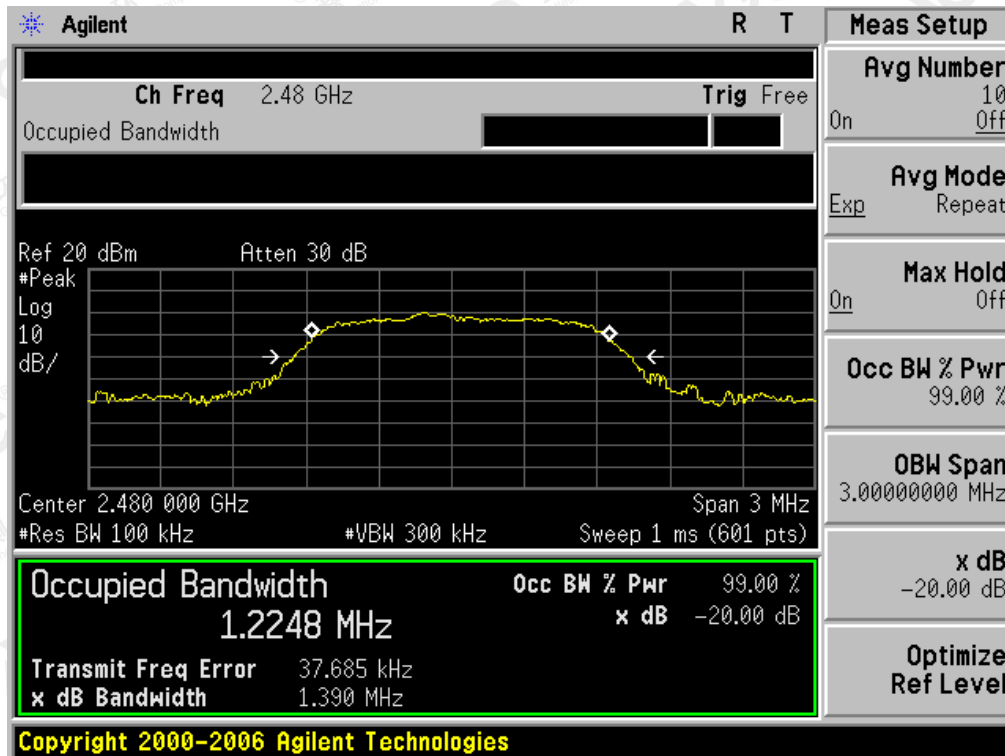

The results shown in this test report refer only to the sample(s) tested unless otherwise stated and the sample(s) are retained for 30 days only. The document is issued by AGC, this document cannot be reproduced except in full with our prior written permission. The more details and the authenticity of the report will be confirmed at <http://www.agc-cert.com>.

| BLUETOOTH 3MBPS LIMITS AND MEASUREMENT RESULT | | | | |
|---|--------------------|--------------|---------------|--------|
| Applicable Limits | Measurement Result | | | |
| | Test Data (MHz) | | | Result |
| | | 99%OBW (MHz) | -20dB BW(MHz) | |
| N/A | Low Channel | 1.234 | 1.386 | PASS |
| | Middle Channel | 1.227 | 1.394 | PASS |
| | High Channel | 1.233 | 1.402 | PASS |

TEST PLOT OF BANDWIDTH FOR LOW CHANNEL

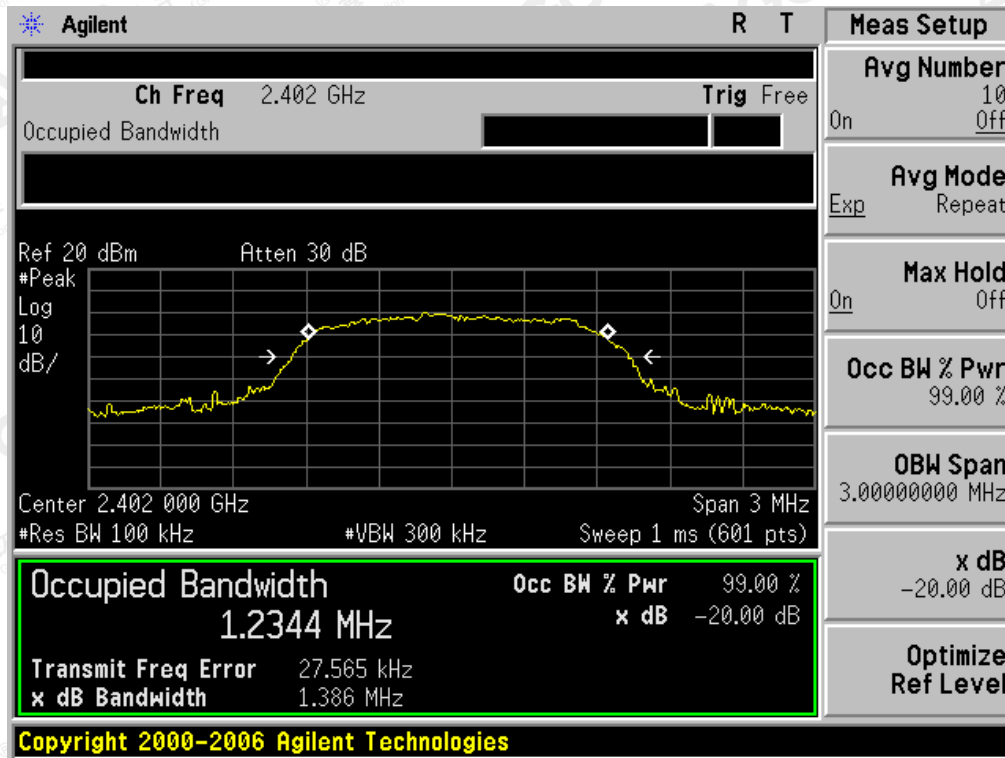

The results shown in this test report refer only to the sample(s) tested unless otherwise stated and the sample(s) are retained for 30 days only. The document is issued by AGC, this document cannot be reproduced except in full with our prior written permission. The more details and the authenticity of the report will be confirmed at <http://www.agc-cert.com>.

TEST PLOT OF BANDWIDTH FOR MIDDLE CHANNEL

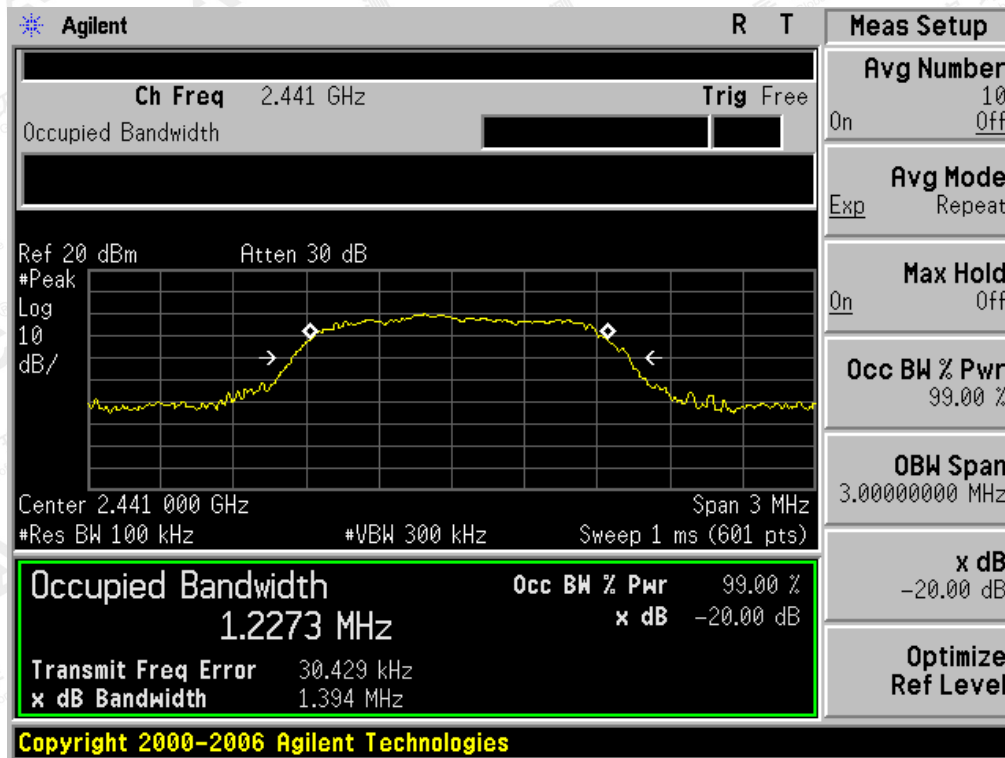

TEST PLOT OF BANDWIDTH FOR HIGH CHANNEL

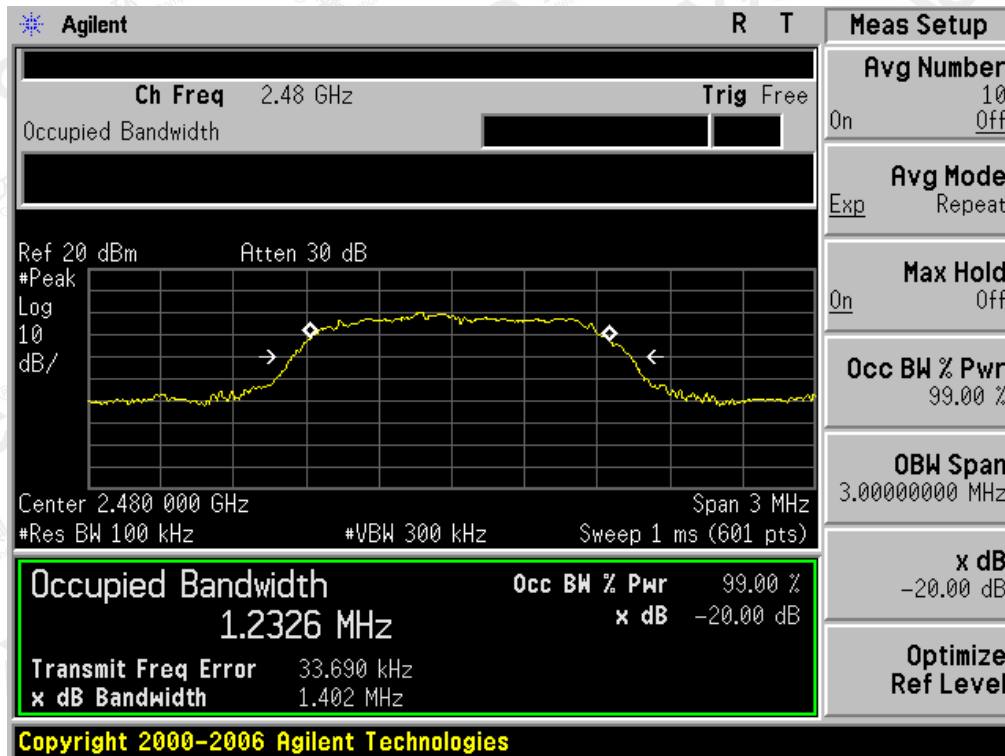

The results shown in this test report refer only to the sample(s) tested otherwise stated and the sample(s) are retained for 30 days only. The document is issued by AGC, this document cannot be reproduced except in full with our prior written permission. The more details and the authenticity of the report will be confirmed at <http://www.agc-cert.com>.

10. CONDUCTED SPURIOUS EMISSION

10.1. MEASUREMENT PROCEDURE

1. Connect EUT RF output port to the Spectrum Analyzer through an RF attenuator
2. Set the EUT Work on the top, the Middle and the bottom operation frequency individually.
3. Set the Span = wide enough to capture the peak level of the in-band emission and all spurious emissions from the lowest frequency generated in the EUT up through the 10th harmonic.
RBW = 100 kHz; VBW = 300kHz; Sweep = auto; Detector function = peak.
4. Set SPA Trace 1 Max hold, then View.

10.2. TEST SET-UP (BLOCK DIAGRAM OF CONFIGURATION)

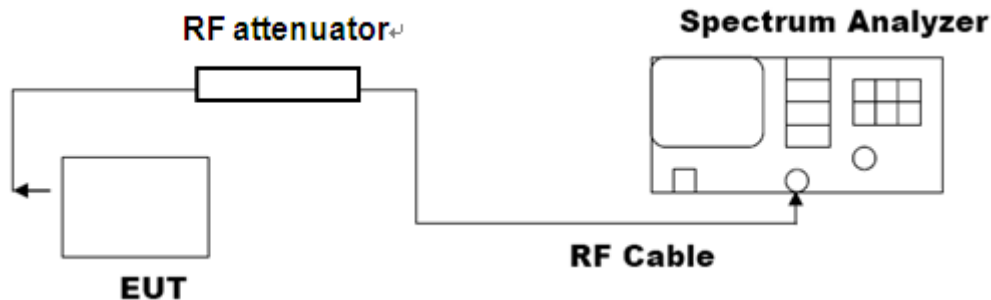

10.3. LIMITS AND MEASUREMENT RESULT

| LIMITS AND MEASUREMENT RESULT | | |
|--|--|--------|
| Applicable Limits | Measurement Result | |
| | Test Data | Result |
| In any 100 KHz Bandwidth Outside the frequency band in which the spread spectrum intentional radiator is operating, the radio frequency power that is produce by the intentional radiator shall be at least 20 dB below that in 100KHz bandwidth within the band that contains the highest level of the desired power. In addition, radiation emissions which fall in the restricted bands, as defined in §15.205(a), must also comply with the radiated emission limits specified in§15.209(a) | At least -20dBc than the limit Specified on the BOTTOM Channel | PASS |
| | At least -20dBc than the limit Specified on the TOP Channel | PASS |

The results shown in this test report refer only to the sample(s) tested unless otherwise stated and the sample(s) are retained for 30 days only. The document is issued by AGC, this document cannot be reproduced except in full with our prior written permission. The more details and the authenticity of the report will be confirmed at <http://www.agc-cert.com>.

TEST PLOT OF OUT OF BAND EMISSIONS WITH THE WORST CASE
OF 8DPSK MODULATION IN LOW CHANNEL

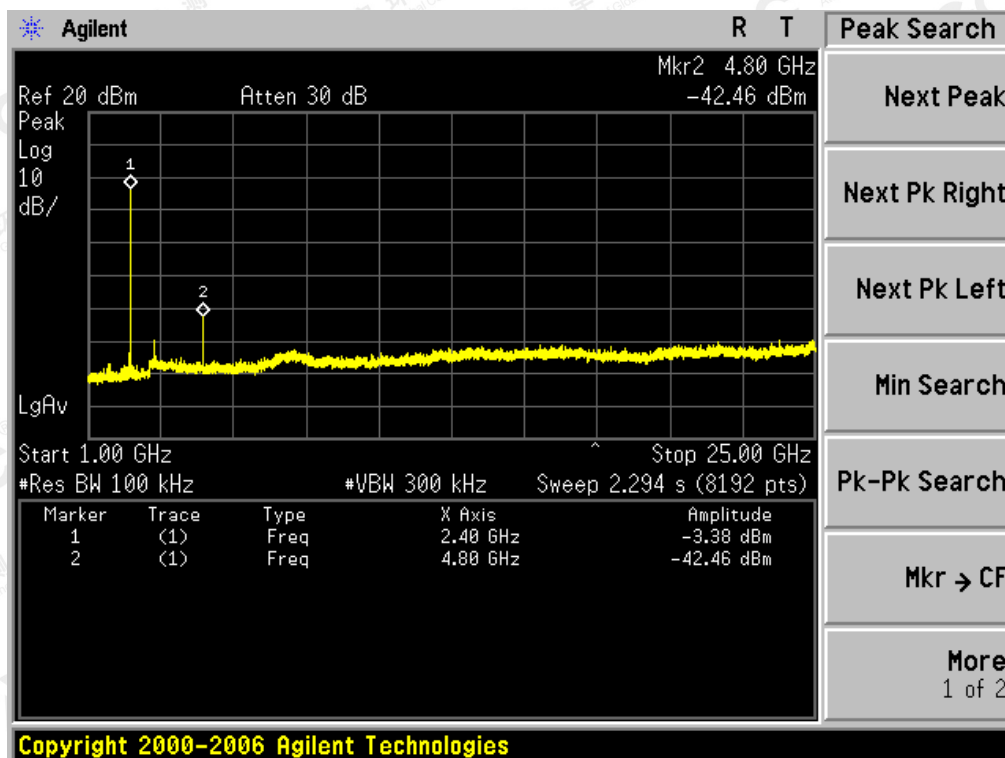
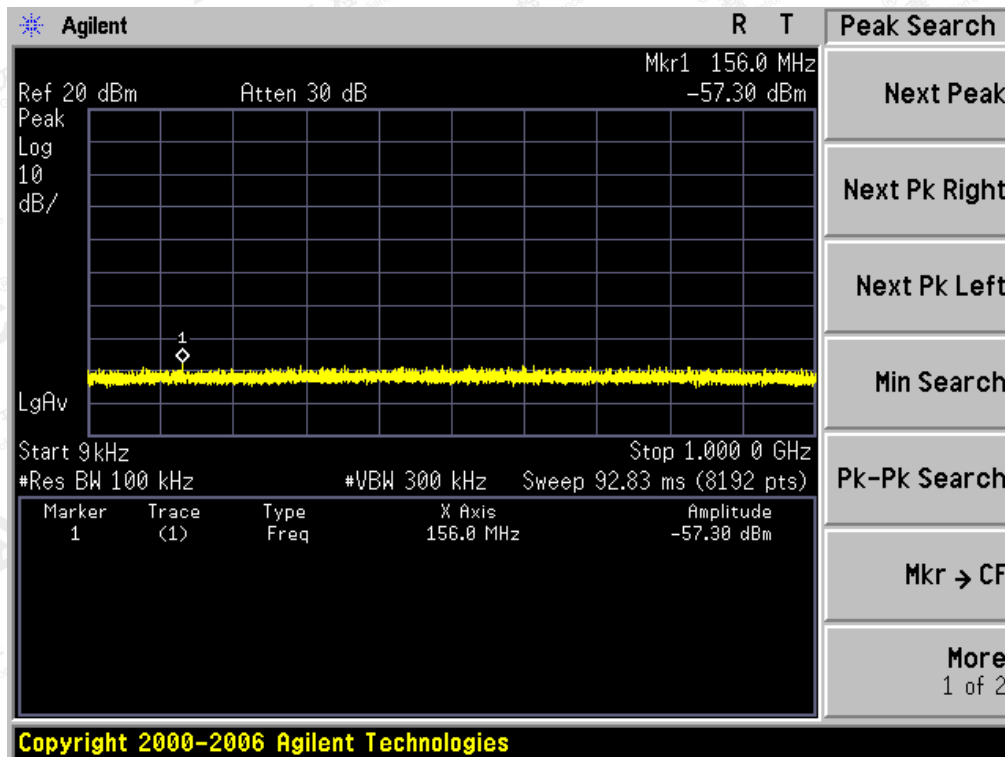

The results shown in this test report refer only to the sample(s) tested otherwise stated and the sample(s) are retained for 30 days only. The document is issued by AGC, this document cannot be reproduced except in full with our prior written permission. The more details and the authenticity of the report will be confirmed at <http://www.agc-cert.com>.

TEST PLOT OF OUT OF BAND EMISSIONS
OF 8DPSK MODULATION IN MIDDLE CHANNEL

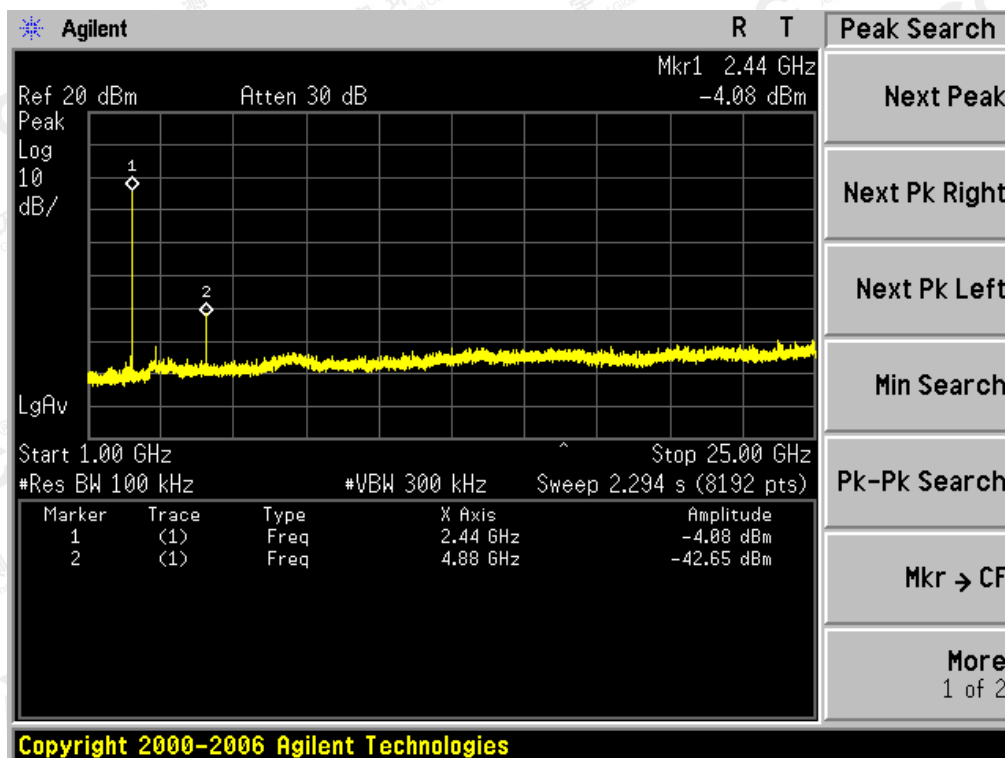
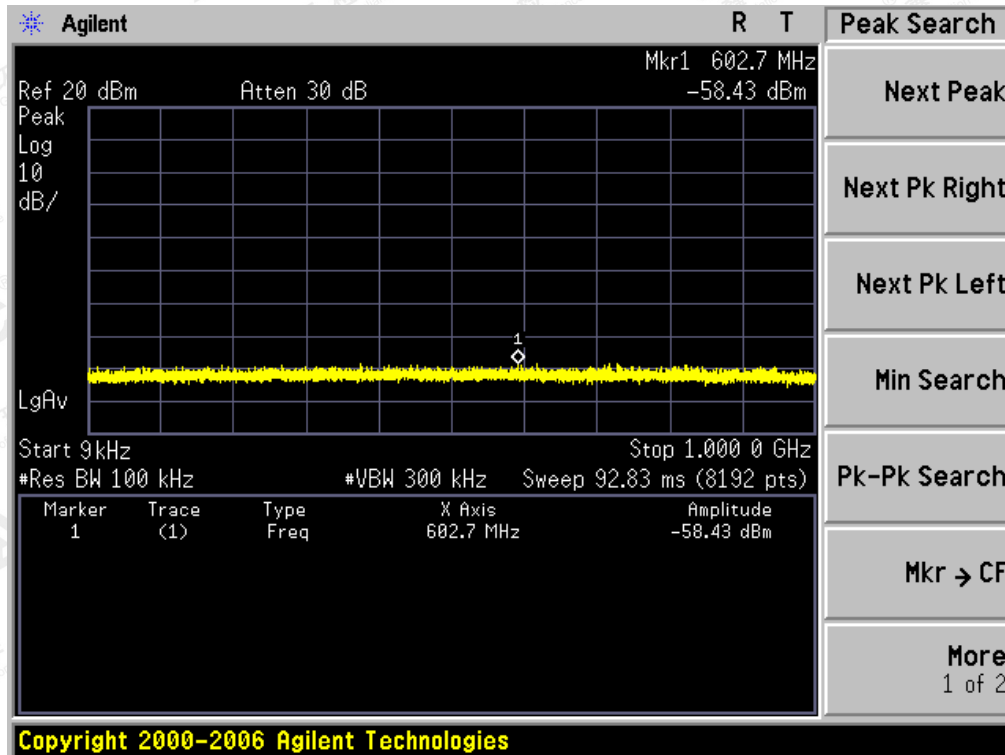

The results shown in this test report refer only to the sample(s) tested otherwise stated and the sample(s) are retained for 30 days only. The document is issued by AGC, this document cannot be reproduced except in full with our prior written permission. The more details and the authenticity of the report will be confirmed at <http://www.agc-cert.com>.

TEST PLOT OF OUT OF BAND EMISSIONS
OF 8DPSK MODULATION IN HIGH CHANNEL

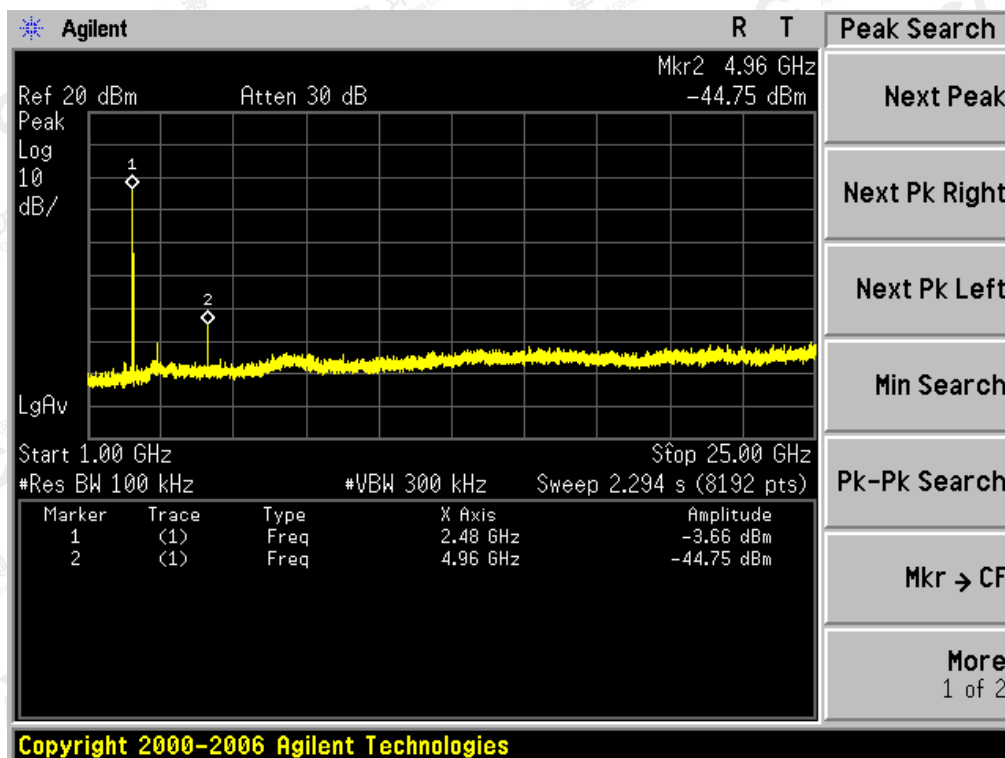
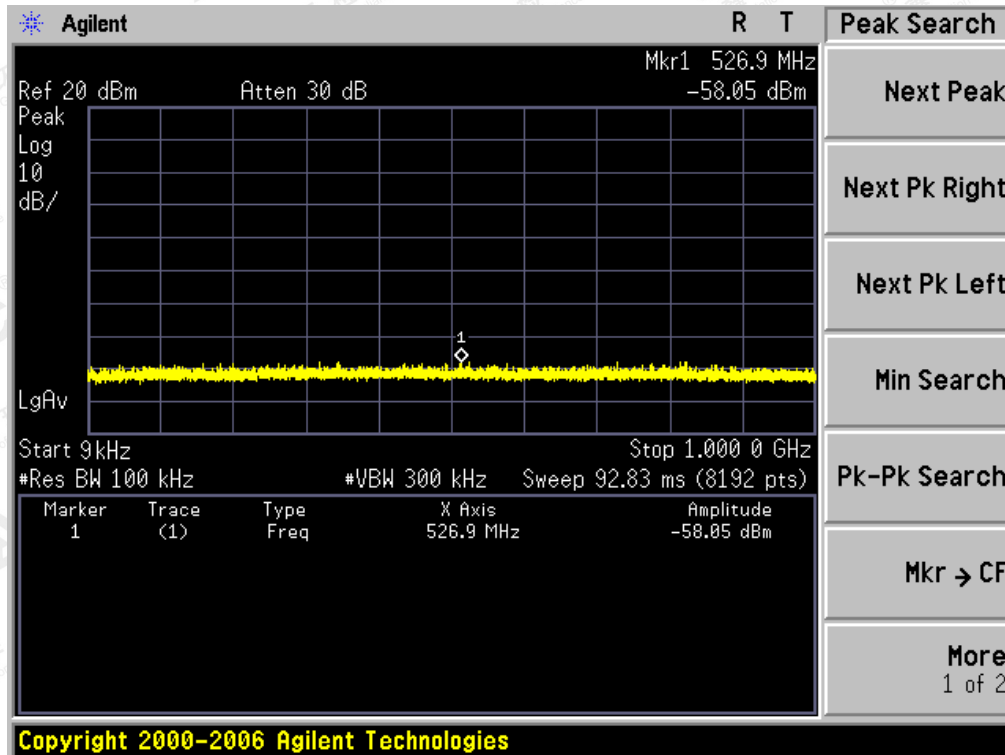

The results shown in this test report refer only to the sample(s) tested otherwise stated and the sample(s) are retained for 30 days only. The document is issued by AGC, this document cannot be reproduced except in full with our prior written permission. The more details and the authenticity of the report will be confirmed at <http://www.agc-cert.com>.

11. RADIATED EMISSION

11.1. TEST LIMIT

| Frequency (MHz) | Distance Meters | Field Strengths Limit | |
|--------------------|--------------------|--|----------------|
| | | μ V/m | dB(μ V)/m |
| 0.009 ~ 0.490 | 300 | 2400/F(kHz) | --- |
| 0.490 ~ 1.705 | 30 | 24000/F(kHz) | --- |
| 1.705 ~ 30 | 30 | 30 | --- |
| 30 ~ 88 | 3 | 100 | 40.0 |
| 88 ~ 216 | 3 | 150 | 43.5 |
| 216 ~ 960 | 3 | 200 | 46.0 |
| 960 ~ 1000 | 3 | 500 | 54.0 |
| Above 1000 | 3 | Other:74.0 dB(μ V)/m (Peak) 54.0 dB(μ V)/m (Average) | |

Remark: (1) Emission level dB μ V = 20 log Emission level μ V/m
 (2) The smaller limit shall apply at the cross point between two frequency bands.
 (3) Distance is the distance in meters between the measuring instrument, antenna and the closest point of any part of the device or system.

11.2. MEASUREMENT PROCEDURE

- The measuring distance of 3m shall be used for measurements. The EUT was placed on the top of a rotating table 0.8 meter above the ground at a 3 meter semi-anechoic chamber. The table was rotated 360 degrees to determine the position of the highest radiation(Below 1GHz)
- The measuring distance of 3m shall used for measurements. The EUT was placed on the top of a rotating table 1.5 meter above the ground at a 3 meter semi-anechoic chamber. The table was rotated 360 degrees to determine the position of the highest radiation(Above 1GHz)
- The height of the test antenna shall vary between 1m to 4m.Both horizontal and vertical polarization Of the antenna are set to make the measurement.
- The initial step in collecting radiated emission data is a receive peak detector mode. Pre-scanning the measurement frequency range. Significant peaks are then marked and then Quasi Peak detector mode re-measured.
- All readings are peak unless otherwise stated QP in column of Note. Peak denoted that the Peak reading compliance with the QP limits and then QP Mode measurement didn't perform(Below 1GHz)
- All readings are Peak mode value unless otherwise stated AVG in column of Note. If the Peak mode measured value compliance with the Peak limits and lower than AVG Limits, the EUT shall be deemed to meet Peak&AVG limits and then only Peak mode was measured, but AVG mode didn't perform.(Above 1GHz)

The results shown in this test report refer only to the sample(s) tested unless otherwise stated and the sample(s) are retained for 30 days only. The document is issued by AGC, this document cannot be reproduced except in full with our prior written permission. The more details and the authenticity of the report will be confirmed at <http://www.agc-cert.com>.

The following table is the setting of spectrum analyzer and receiver.

| Spectrum Parameter | Setting |
|-----------------------|--|
| Start ~Stop Frequency | 9KHz~150KHz/RB 200Hz for QP |
| Start ~Stop Frequency | 150KHz~30MHz/RB 9KHz for QP |
| Start ~Stop Frequency | 30MHz~1000MHz/RB 120KHz for QP |
| Start ~Stop Frequency | 1GHz~26.5GHz RBW 1MHz/ VBW 3MHz for Peak, RBW 1MHz/ VBW 10Hz for Average |

| Receiver Parameter | Setting |
|-----------------------|--------------------------------|
| Start ~Stop Frequency | 9KHz~150KHz/RB 200Hz for QP |
| Start ~Stop Frequency | 150KHz~30MHz/RB 9KHz for QP |
| Start ~Stop Frequency | 30MHz~1000MHz/RB 120KHz for QP |

The results shown in this test report refer only to the sample(s) tested unless otherwise stated and the sample(s) are retained for 30 days only. The document is issued by AGC, this document cannot be reproduced except in full with our prior written permission. The more details and the authenticity of the report will be confirmed at <http://www.agc-cert.com>.

11.3. TEST SETUP

RADIATED EMISSION TEST SETUP BELOW 30MHz

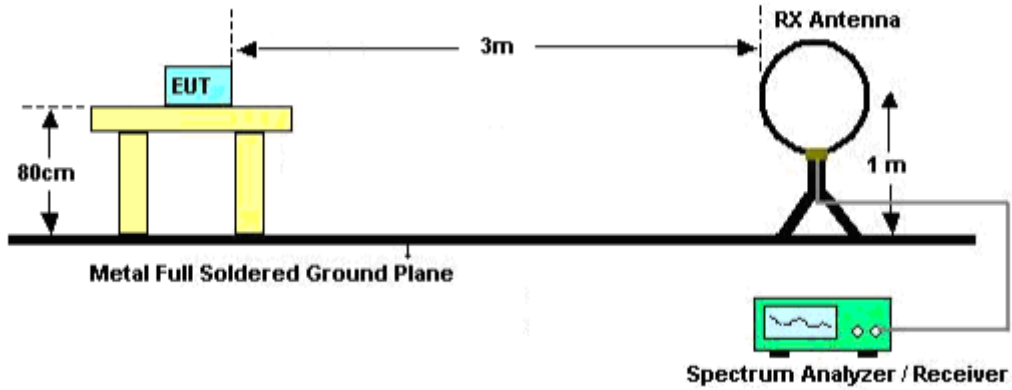

RADIATED EMISSION TEST SETUP 30MHz-1000MHz

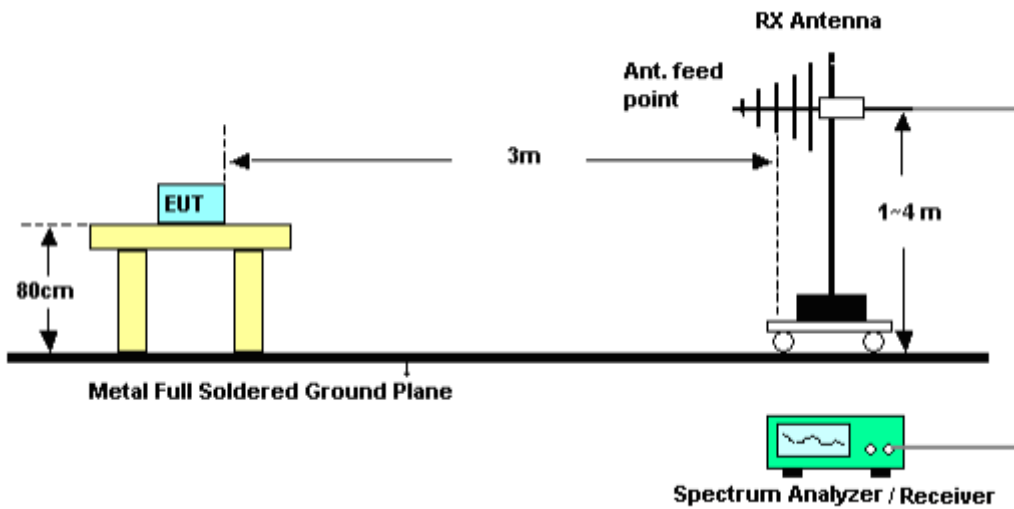

The results shown in this test report refer only to the sample(s) tested unless otherwise stated and the sample(s) are retained for 30 days only. The document is issued by AGC, this document cannot be reproduced except in full with our prior written permission. The more details and the authenticity of the report will be confirmed at <http://www.agc-cert.com>.

RADIATED EMISSION TEST SETUP ABOVE 1000MHz

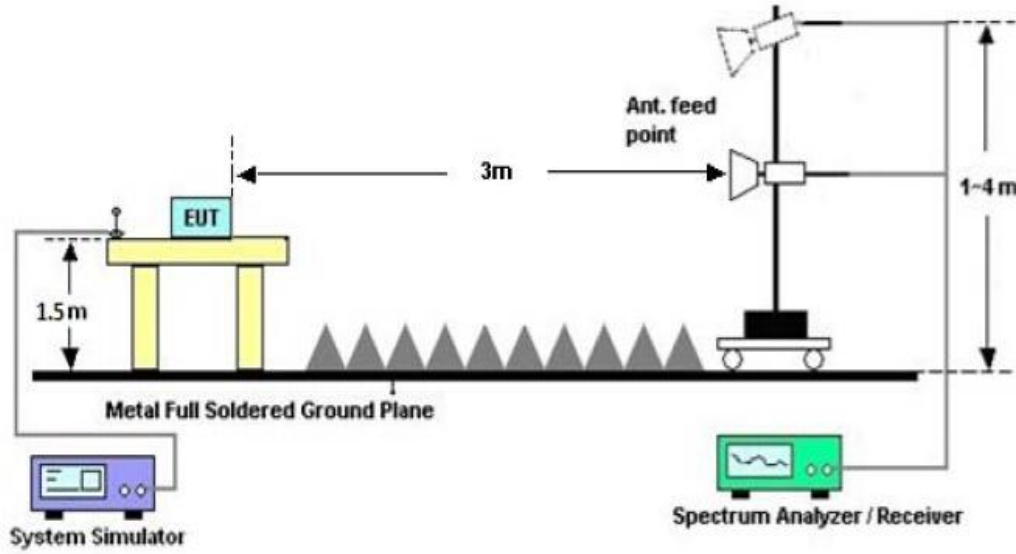

The results shown in this test report refer only to the sample(s) tested unless otherwise stated and the sample(s) are retained for 30 days only. The document is issued by AGC, this document cannot be reproduced except in full with our prior written permission. The more details and the authenticity of the report will be confirmed at <http://www.agc-cert.com>.

11.4. TEST RESULT

(Worst Modulation: 8DPSK)

RADIATED EMISSION BELOW 30MHZ

No emission found between lowest internal used/generated frequencies to 30MHz.

The results shown in this test report refer only to the sample(s) tested unless otherwise stated and the sample(s) are retained for 30 days only. The document is issued by AGC, this document cannot be reproduced except in full with our prior written permission. The more details and the authenticity of the report will be confirmed at <http://www.agc-cert.com>.

RADIATED EMISSION BELOW 1GHz

RADIATED EMISSION TEST- (30MHz-1GHz)-LOW CHANNEL-HORIZONTAL

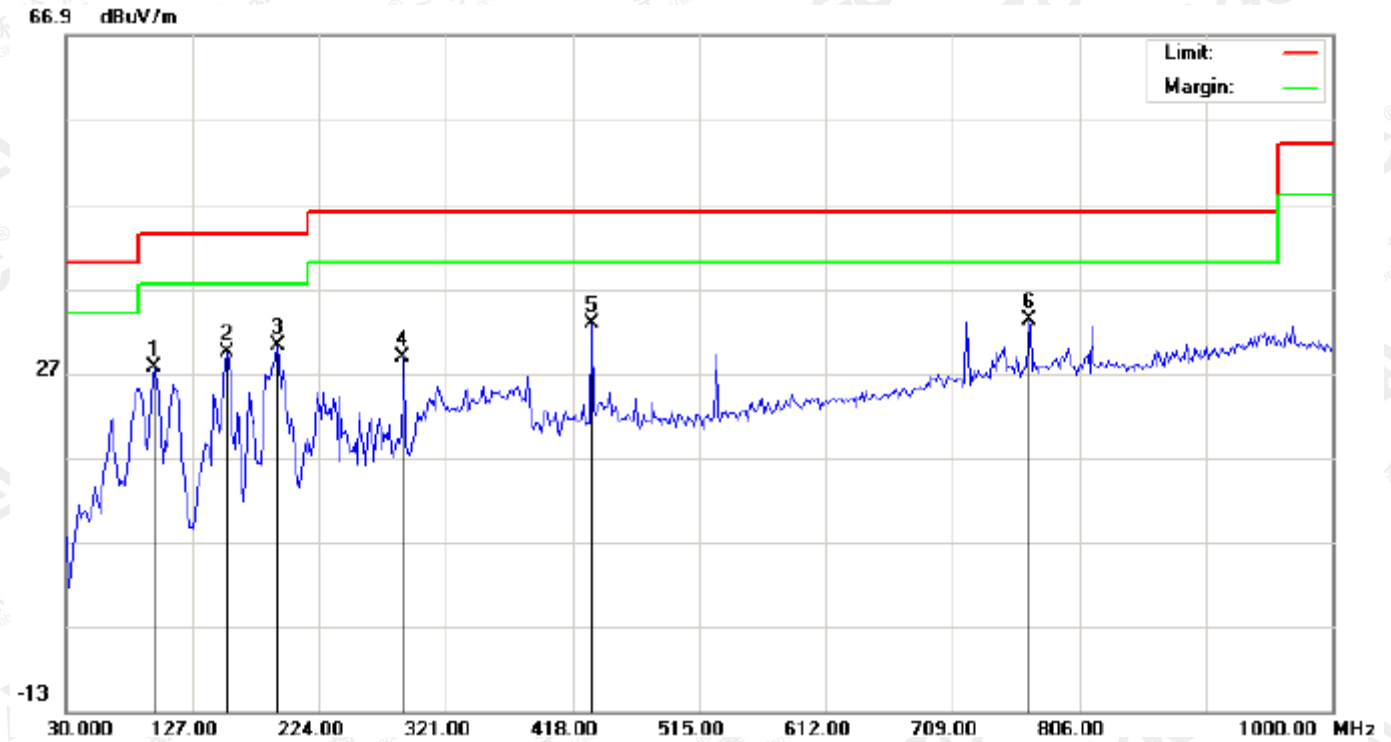

| No. | Mk | Freq. | Reading | Factor | Measurement | Limit | Over | Detector | Antenna Height | Table Degree | Comment |
|-----|----|----------|---------|--------|-------------|--------|--------|----------|----------------|--------------|---------|
| | | MHz | dBuV | dB/m | dBuV/m | dBuV/m | dB | | cm | degree | |
| 1 | | 97.9000 | 19.20 | 8.38 | 27.58 | 43.50 | -15.92 | peak | | | |
| 2 | | 152.8667 | 17.27 | 12.07 | 29.34 | 43.50 | -14.16 | peak | | | |
| 3 | | 191.6667 | 18.68 | 11.61 | 30.29 | 43.50 | -13.21 | peak | | | |
| 4 | | 288.6666 | 15.39 | 13.48 | 28.87 | 46.00 | -17.13 | peak | | | |
| 5 | | 432.5500 | 12.67 | 20.06 | 32.73 | 46.00 | -13.27 | peak | | | |
| 6 | * | 767.2000 | 6.33 | 26.87 | 33.20 | 46.00 | -12.80 | peak | | | |

RESULT: PASS

The results shown in this test report refer only to the sample(s) tested unless otherwise stated and the sample(s) are retained for 30 days only. The document is issued by AGC, this document cannot be reproduced except in full with our prior written permission. The more details and the authenticity of the report will be confirmed at <http://www.agc-cert.com>.

RADIATED EMISSION TEST- (30MHz-1GHz)-LOW CHANNEL -VERTICAL

66.9 dBuV/m

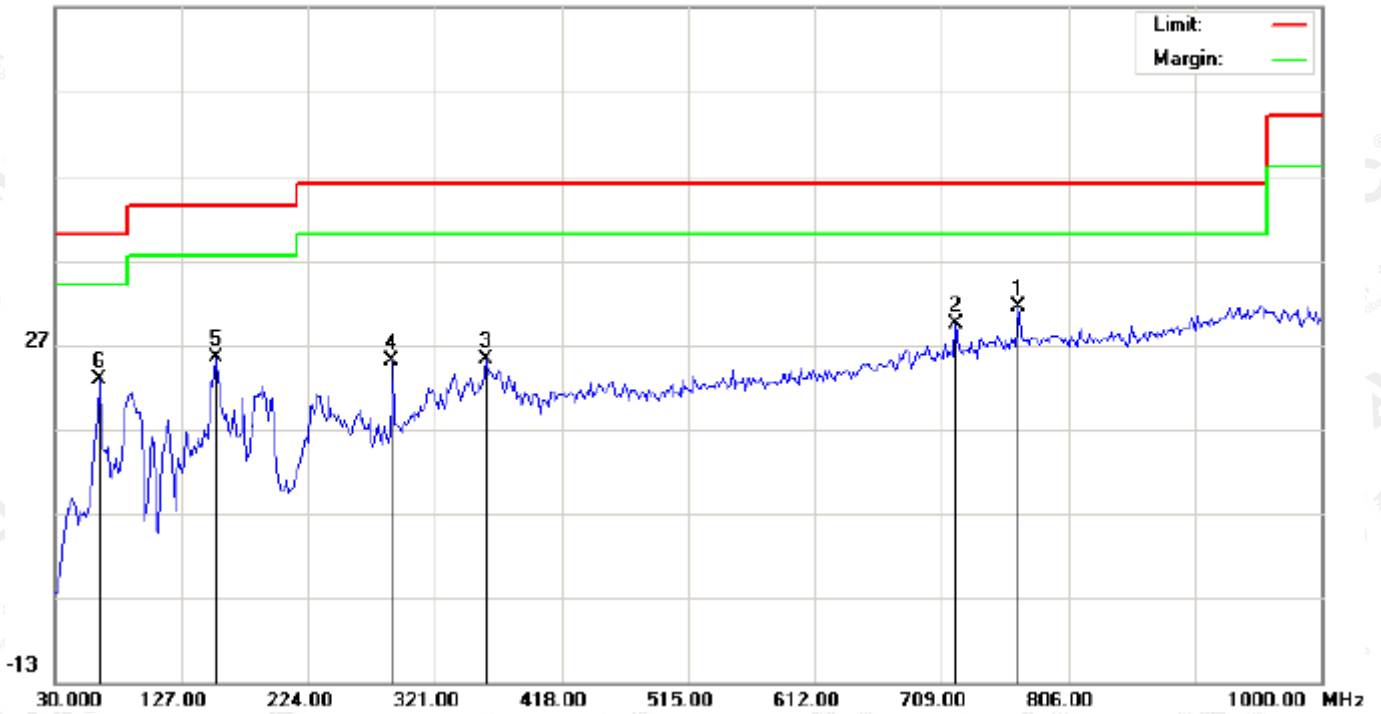

| No. | Mk | Freq. | Reading | Factor | Measurement | Limit | Over | Detector | Antenna | Table | Comment |
|-----|----|----------|---------|--------|-------------|--------|--------|----------|---------|--------|---------|
| | | MHz | dBuV | dB/m | dBuV/m | dBuV/m | dB | | Height | Degree | |
| 1 | * | 767.2000 | 4.48 | 26.87 | 31.35 | 46.00 | -14.65 | peak | cm | degree | |
| 2 | | 720.3167 | 3.56 | 25.78 | 29.34 | 46.00 | -16.66 | peak | | | |
| 3 | | 359.8000 | 6.45 | 18.80 | 25.25 | 46.00 | -20.75 | peak | | | |
| 4 | | 288.6666 | 9.87 | 15.07 | 24.94 | 46.00 | -21.06 | peak | | | |
| 5 | | 152.8667 | 10.09 | 15.28 | 25.37 | 43.50 | -18.13 | peak | | | |
| 6 | | 63.9500 | 16.20 | 6.61 | 22.81 | 40.00 | -17.19 | peak | | | |

RESULT: PASS

Note: 1. Factor=Antenna Factor + Cable loss, Margin=Measurement-Limit.

2. The "Factor" value can be calculated automatically by software of measurement system.

The results shown in this test report refer only to the sample(s) tested unless otherwise stated and the sample(s) are retained for 30 days only. The document is issued by AGC, this document cannot be reproduced except in full with our prior written permission. The more details and the authenticity of the report will be confirmed at <http://www.agc-cert.com>.

RADIATED EMISSION TEST- (30MHz-1GHz)-MIDDLE CHANNEL-HORIZONTAL

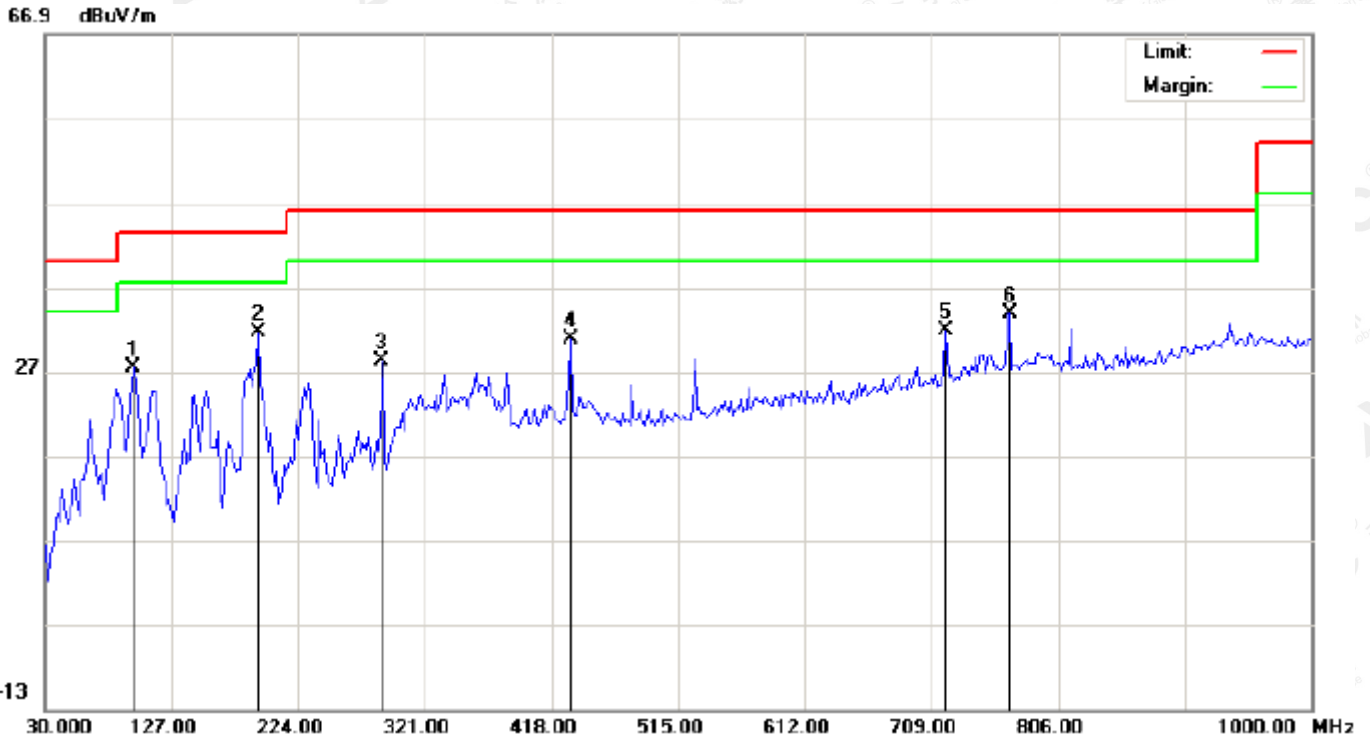

| No. | Mk | Freq. | Reading | Factor | Measurement | Limit | Over | Detector | Antenna Height | Table Degree | Comment |
|-----|----|----------|---------|--------|-------------|--------|--------|----------|----------------|--------------|---------|
| | | MHz | dBuV | dB/m | dBuV/m | dBuV/m | dB | | | | |
| 1 | | 97.9000 | 19.07 | 8.38 | 27.45 | 43.50 | -16.05 | peak | | | |
| 2 | * | 193.2833 | 19.96 | 11.69 | 31.65 | 43.50 | -11.85 | peak | | | |
| 3 | | 288.6666 | 14.70 | 13.48 | 28.18 | 46.00 | -17.82 | peak | | | |
| 4 | | 432.5500 | 10.71 | 20.06 | 30.77 | 46.00 | -15.23 | peak | | | |
| 5 | | 720.3167 | 6.08 | 25.79 | 31.87 | 46.00 | -14.13 | peak | | | |
| 6 | | 768.8167 | 6.84 | 26.89 | 33.73 | 46.00 | -12.27 | peak | | | |

RESULT: PASS

The results shown in this test report refer only to the sample(s) tested unless otherwise stated and the sample(s) are retained for 30 days only. The document is issued by AGC, this document cannot be reproduced except in full with our prior written permission. The more details and the authenticity of the report will be confirmed at <http://www.agc-cert.com>.

RADIATED EMISSION TEST- (30MHz-1GHz)-MIDDLE CHANNEL -VERTICAL

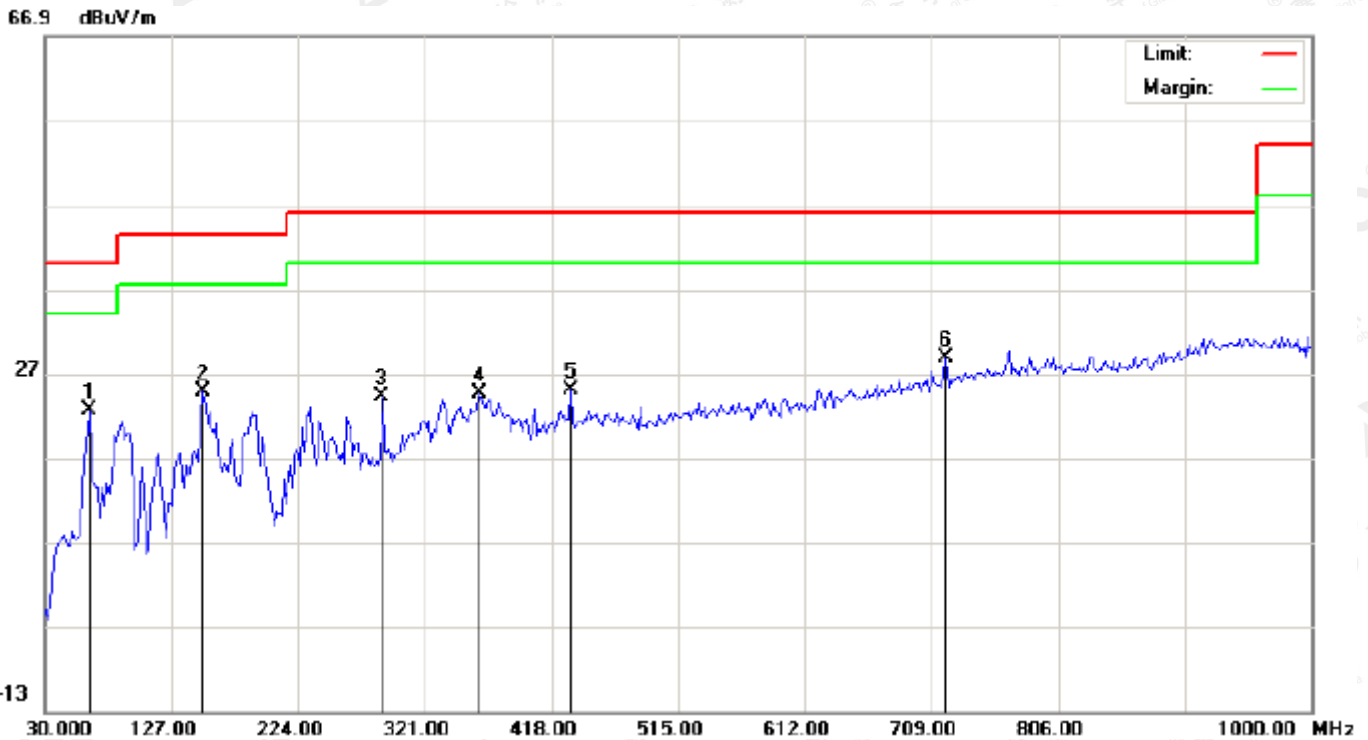

| No. | Mk | Freq. | Reading | Factor | Measurement | Limit | Over | Detector | Antenna Height | Table Degree | Comment |
|-----|----|----------|---------|--------|-------------|--------|--------|----------|----------------|--------------|---------|
| | | MHz | dBuV | dB/m | dBuV/m | dBuV/m | dB | | | | |
| 1 | | 63.9500 | 16.02 | 6.61 | 22.63 | 40.00 | -17.37 | peak | | | |
| 2 | | 151.2500 | 9.50 | 15.27 | 24.77 | 43.50 | -18.73 | peak | | | |
| 3 | | 288.6666 | 9.19 | 15.07 | 24.26 | 46.00 | -21.74 | peak | | | |
| 4 | | 363.0333 | 5.73 | 18.83 | 24.56 | 46.00 | -21.44 | peak | | | |
| 5 | | 432.5500 | 4.99 | 20.06 | 25.05 | 46.00 | -20.95 | peak | | | |
| 6 | * | 720.3167 | 3.11 | 25.78 | 28.89 | 46.00 | -17.11 | peak | | | |

RESULT: PASS

Note: 1. Factor=Antenna Factor + Cable loss, Margin=Measurement-Limit.

2. The "Factor" value can be calculated automatically by software of measurement system.

The results shown in this test report refer only to the sample(s) tested unless otherwise stated and the sample(s) are retained for 30 days only. The document is issued by AGC, this document cannot be reproduced except in full with our prior written permission. The more details and the authenticity of the report will be confirmed at <http://www.agc-cert.com>.

RADIATED EMISSION TEST- (30MHz-1GHz)-HIGH CHANNEL-HORIZONTAL

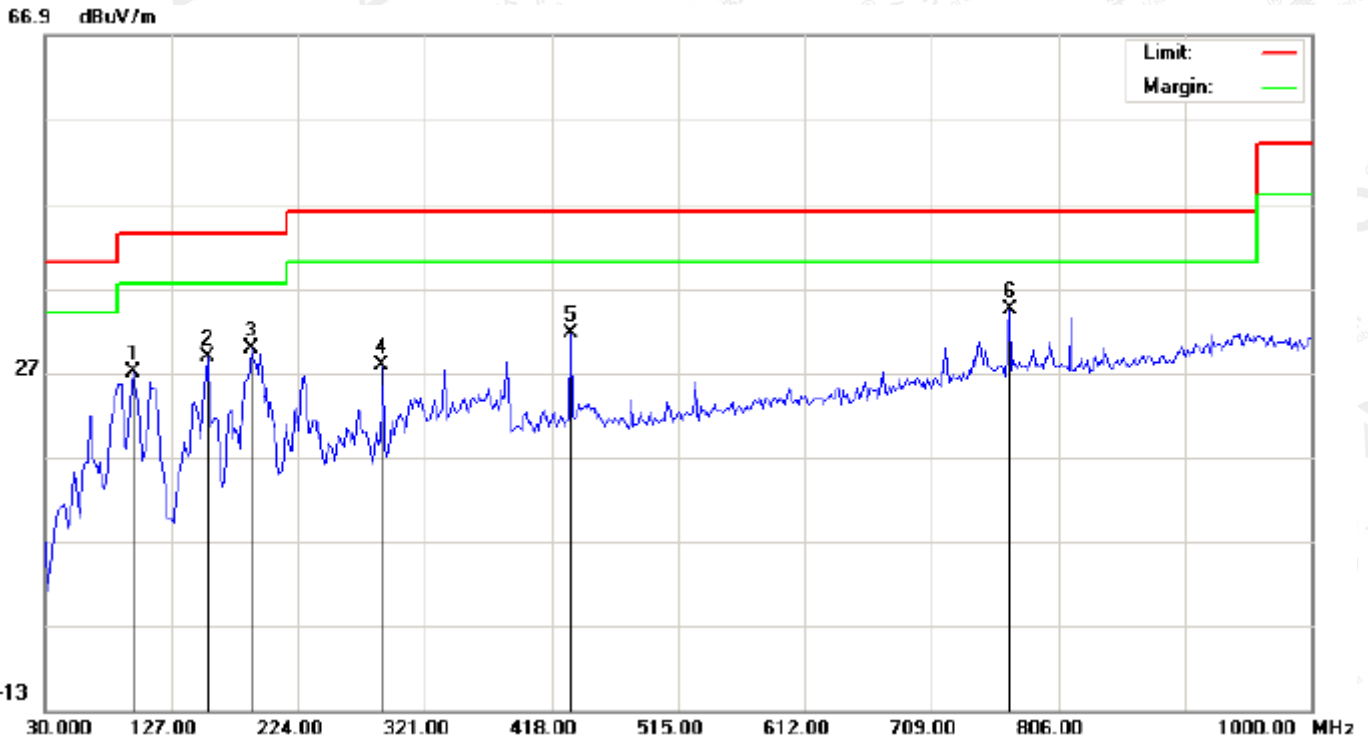

| No. | Mk | Freq. | Reading | Factor | Measurement | Limit | Over | Detector | Antenna Height | Table Degree | Comment |
|-----|----|----------|---------|--------|-------------|--------|--------|----------|----------------|--------------|---------|
| | | MHz | dBuV | dB/m | dBuV/m | dBuV/m | dB | | cm | degree | |
| 1 | | 97.9000 | 18.68 | 8.38 | 27.06 | 43.50 | -16.44 | peak | | | |
| 2 | | 154.4832 | 17.19 | 11.67 | 28.86 | 43.50 | -14.64 | peak | | | |
| 3 | | 188.4333 | 18.42 | 11.46 | 29.88 | 43.50 | -13.62 | peak | | | |
| 4 | | 288.6666 | 14.29 | 13.48 | 27.77 | 46.00 | -18.23 | peak | | | |
| 5 | | 432.5500 | 11.49 | 20.06 | 31.55 | 46.00 | -14.45 | peak | | | |
| 6 | * | 768.8167 | 7.43 | 26.89 | 34.32 | 46.00 | -11.68 | peak | | | |

RESULT: PASS

The results shown in this test report refer only to the sample(s) tested unless otherwise stated and the sample(s) are retained for 30 days only. The document is issued by AGC, this document cannot be reproduced except in full with our prior written permission. The more details and the authenticity of the report will be confirmed at <http://www.agc-cert.com>.

RADIATED EMISSION TEST- (30MHz-1GHz)-HIGH CHANNEL -VERTICAL

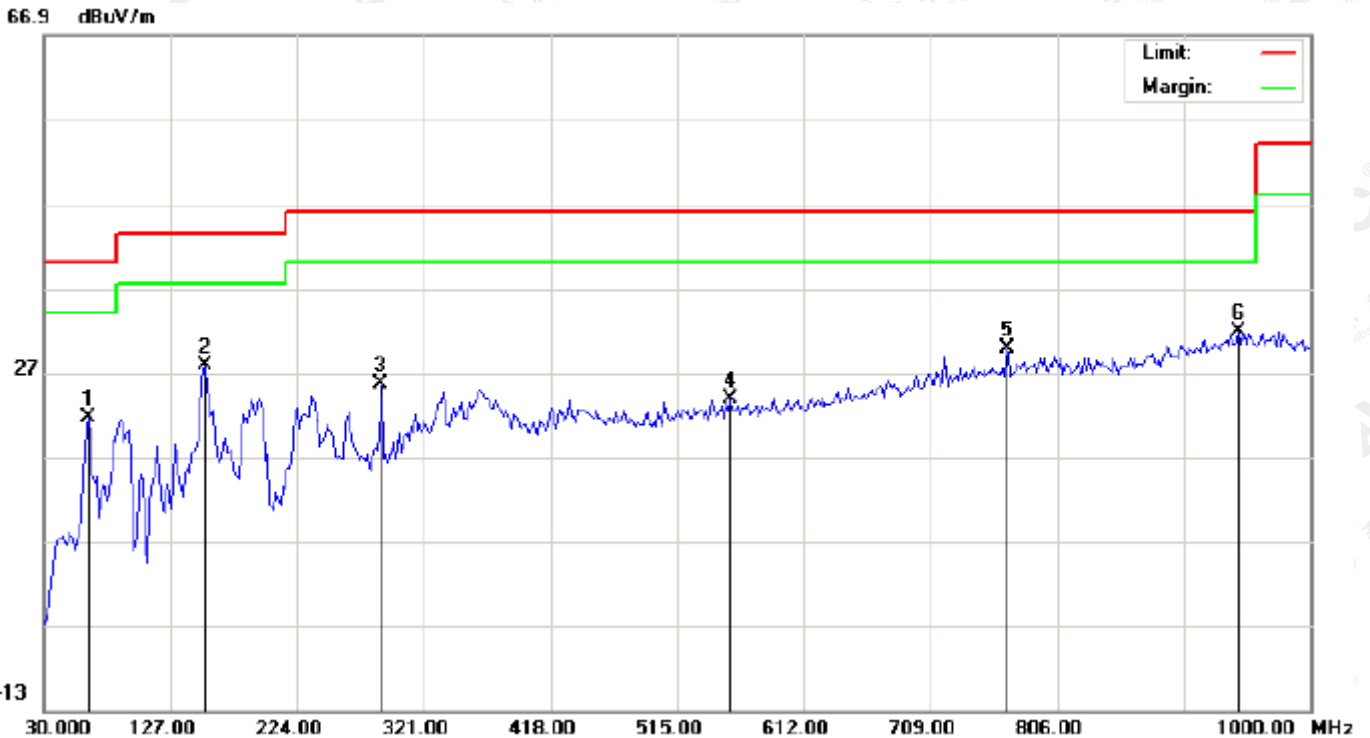

| No. | Mk | Freq. | Reading | Factor | Measurement | Limit | Over | Detector | Antenna | Table | Comment |
|-----|----|----------|---------|--------|-------------|--------|--------|----------|---------|--------|---------|
| | | MHz | dBuV | dB/m | dBuV/m | dBuV/m | dB | | Height | Degree | |
| | | | | | | | | | cm | degree | |
| 1 | | 63.9500 | 14.97 | 6.61 | 21.58 | 40.00 | -18.42 | peak | | | |
| 2 | | 152.8667 | 12.52 | 15.28 | 27.80 | 43.50 | -15.70 | peak | | | |
| 3 | | 288.6666 | 10.49 | 15.07 | 25.56 | 46.00 | -20.44 | peak | | | |
| 4 | | 555.4167 | 1.35 | 22.51 | 23.86 | 46.00 | -22.14 | peak | | | |
| 5 | | 767.2000 | 2.99 | 26.87 | 29.86 | 46.00 | -16.14 | peak | | | |
| 6 | * | 945.0333 | 1.94 | 29.86 | 31.80 | 46.00 | -14.20 | peak | | | |

RESULT: PASS

Note: 1. Factor=Antenna Factor + Cable loss, Margin=Measurement-Limit.

2. The "Factor" value can be calculated automatically by software of measurement system.

The results shown in this test report refer only to the sample(s) tested unless otherwise stated and the sample(s) are retained for 30 days only. The document is issued by AGC, this document cannot be reproduced except in full with our prior written permission. The more details and the authenticity of the report will be confirmed at <http://www.agc-cert.com>.

RADIATED EMISSION ABOVE 1GHz

RADIATED EMISSION ABOVE 1GHz (1-10th Harmonics)-LOW CHANNEL-HORIZONTAL

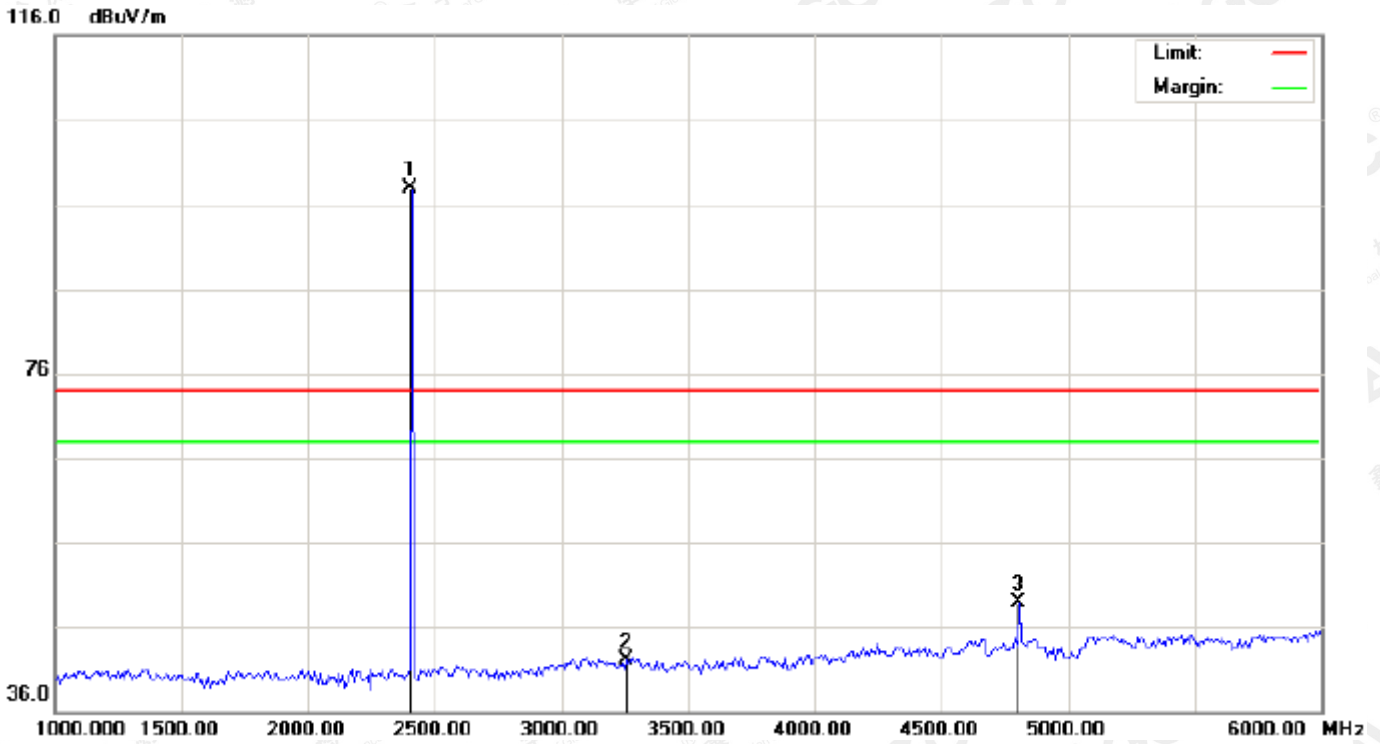

| No. | Mk | Freq. | Reading | Factor | Measurement | Limit | Over | Detector | Antenna | Table | Comment |
|-----|----|----------|---------|--------|-------------|--------|--------|----------|---------|--------|---------|
| | | MHz | dBuV | dB/m | dBuV/m | dBuV/m | dB | | Height | Degree | |
| | | | | | | | | | cm | degree | |
| 1 | * | 2402.000 | 87.62 | 10.32 | 97.94 | 74.00 | 23.94 | peak | | | |
| 2 | | 3256.000 | 30.21 | 11.88 | 42.09 | 74.00 | -31.91 | peak | | | |
| 3 | | 4804.000 | 41.21 | 7.69 | 48.90 | 74.00 | -25.10 | peak | | | |

RESULT: PASS

The results shown in this test report refer only to the sample(s) tested unless otherwise stated and the sample(s) are retained for 30 days only. The document is issued by AGC, this document cannot be reproduced except in full with our prior written permission. The more details and the authenticity of the report will be confirmed at <http://www.agc-cert.com>.

RADIATED EMISSION ABOVE 1GHz (1-10th Harmonics)-LOW CHANNEL –VERTICAL

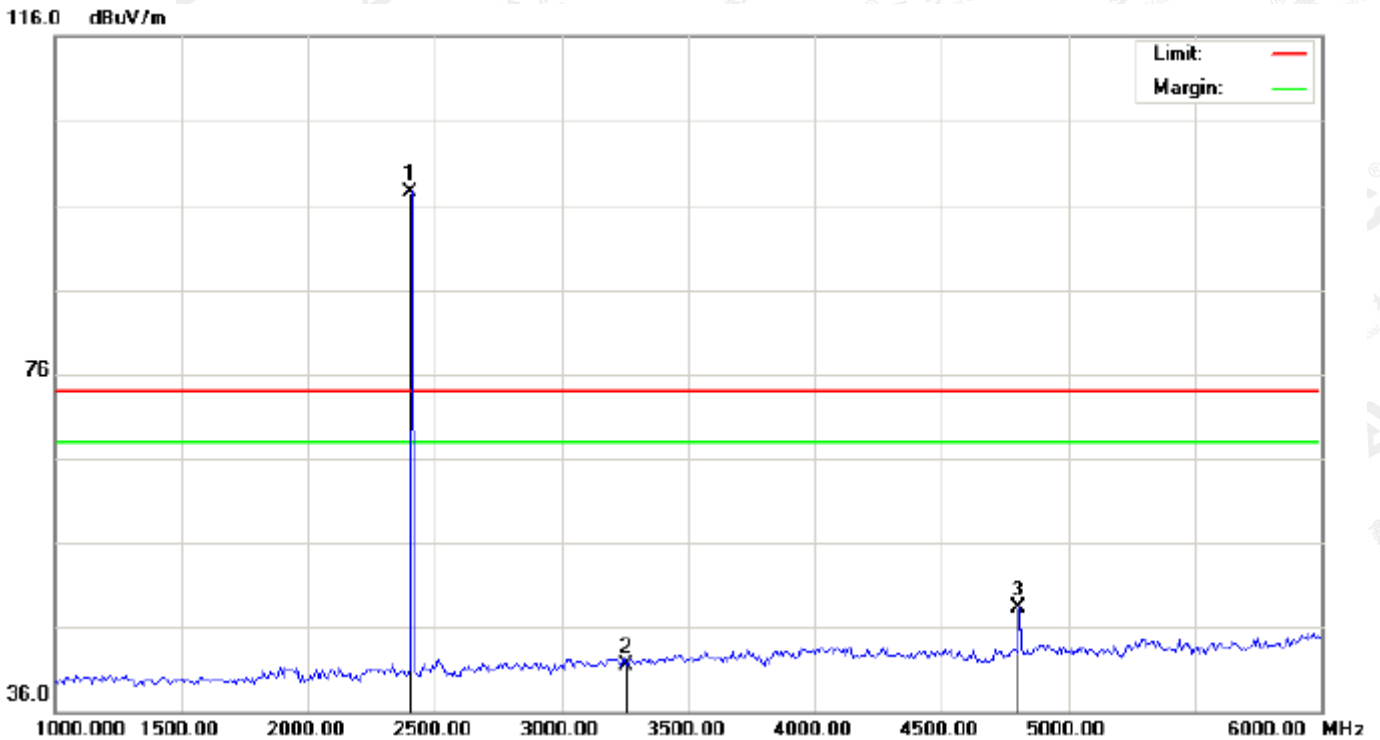

| No. | Mk | Freq. | Reading | Factor | Measurement | Limit | Over | Detector | Antenna | Table | Comment |
|-----|----|----------|---------|--------|-------------|--------|--------|----------|---------|--------|---------|
| | | MHz | dBuV | dB/m | dBuV/m | dBuV/m | dB | | Height | Degree | |
| | | | | | | | | | cm | degree | |
| 1 | * | 2402.000 | 87.20 | 10.32 | 97.52 | 74.00 | 23.52 | peak | | | |
| 2 | | 3256.000 | 29.56 | 11.88 | 41.44 | 74.00 | -32.56 | peak | | | |
| 3 | | 4804.000 | 40.55 | 7.69 | 48.24 | 74.00 | -25.76 | peak | | | |

RESULT: PASS

The results shown in this test report refer only to the sample(s) tested unless otherwise stated and the sample(s) are retained for 30 days only. The document is issued by AGC, this document cannot be reproduced except in full with our prior written permission. The more details and the authenticity of the report will be confirmed at <http://www.agc-cert.com>.

RADIATED EMISSION ABOVE 1GHz (1-10th Harmonics)-MIDDLE CHANNEL-HORIZONTAL

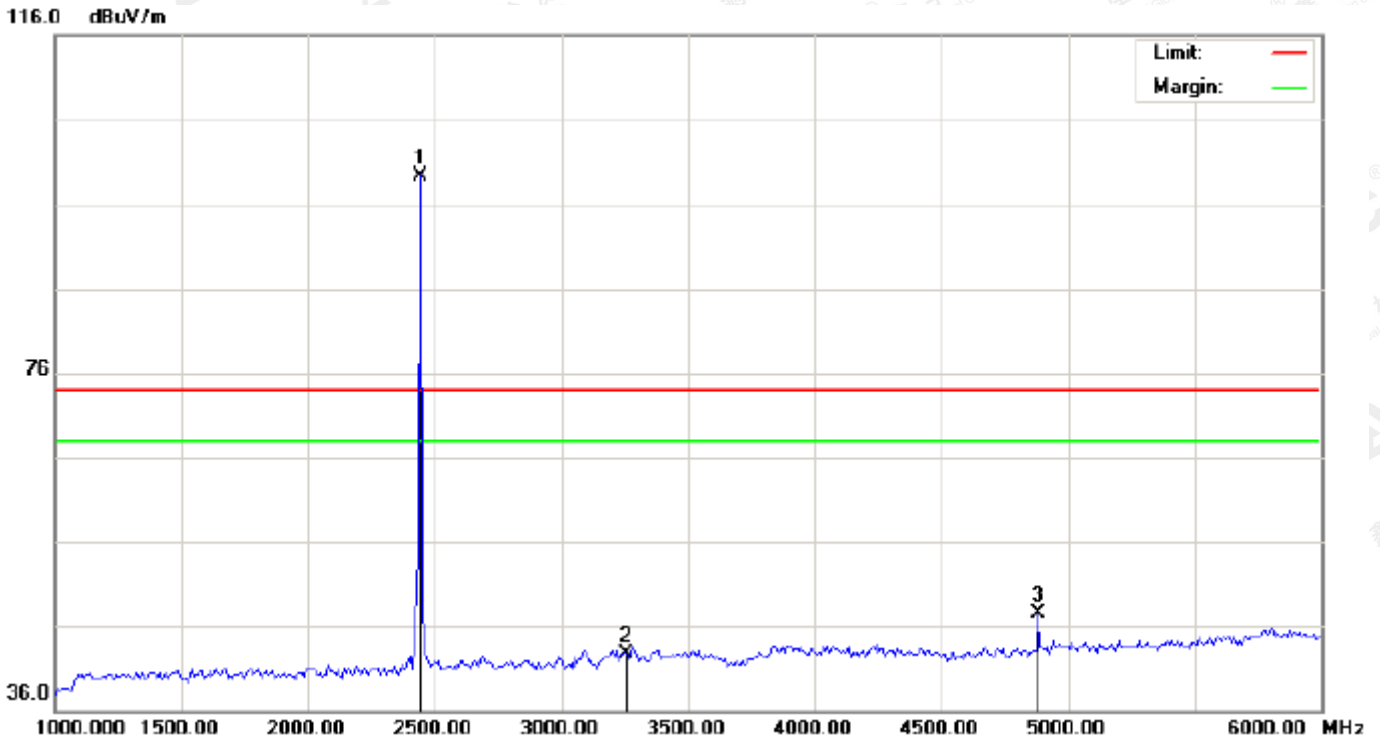

| No. | Mk | Freq. | Reading | Factor | Measurement | Limit | Over | Detector | Antenna | Table | Comment |
|-----|----|----------|---------|--------|-------------|--------|--------|----------|---------|--------|---------|
| | | MHz | dBuV | dB/m | dBuV/m | dBuV/m | dB | | Height | Degree | |
| | | | | | | | | | cm | degree | |
| 1 | * | 2441.000 | 88.89 | 10.36 | 99.25 | 74.00 | 25.25 | peak | | | |
| 2 | | 3256.000 | 30.73 | 11.88 | 42.61 | 74.00 | -31.39 | peak | | | |
| 3 | | 4882.000 | 39.66 | 7.89 | 47.55 | 74.00 | -26.45 | peak | | | |

RESULT: PASS

The results shown in this test report refer only to the sample(s) tested unless otherwise stated and the sample(s) are retained for 30 days only. The document is issued by AGC, this document cannot be reproduced except in full with our prior written permission. The more details and the authenticity of the report will be confirmed at <http://www.agc-cert.com>.

RADIATED EMISSION ABOVE 1GHz (1-10th Harmonics) - MIDDLE CHANNEL -VERTICAL

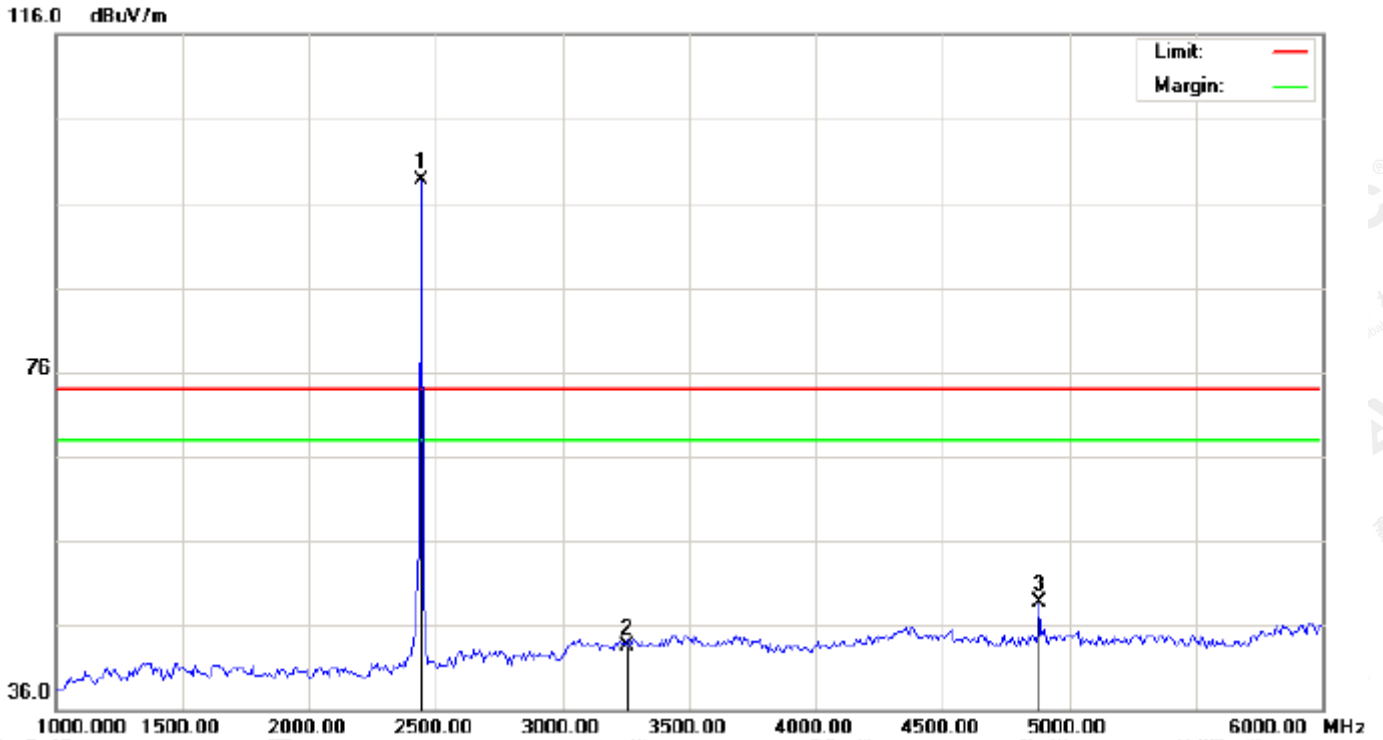

| No. | Mk | Freq. | Reading | Factor | Measurement | Limit | Over | Detector | Antenna | Table | Comment |
|-----|----|----------|---------|--------|-------------|--------|--------|----------|---------|--------|---------|
| | | MHz | dBuV | dB/m | dBuV/m | dBuV/m | dB | | Height | Degree | |
| | | | | | | | | | cm | degree | |
| 1 | * | 2441.000 | 88.43 | 10.36 | 98.79 | 74.00 | 24.79 | peak | | | |
| 2 | | 3259.000 | 31.64 | 11.88 | 43.52 | 74.00 | -30.48 | peak | | | |
| 3 | | 4882.000 | 40.89 | 7.89 | 48.78 | 74.00 | -25.22 | peak | | | |

RESULT: PASS

The results shown in this test report refer only to the sample(s) tested unless otherwise stated and the sample(s) are retained for 30 days only. The document is issued by AGC, this document cannot be reproduced except in full with our prior written permission. The more details and the authenticity of the report will be confirmed at <http://www.agc-cert.com>.

RADIATED EMISSION ABOVE 1GHz (1-10th Harmonics)-HIGH CHANNEL-HORIZONTAL

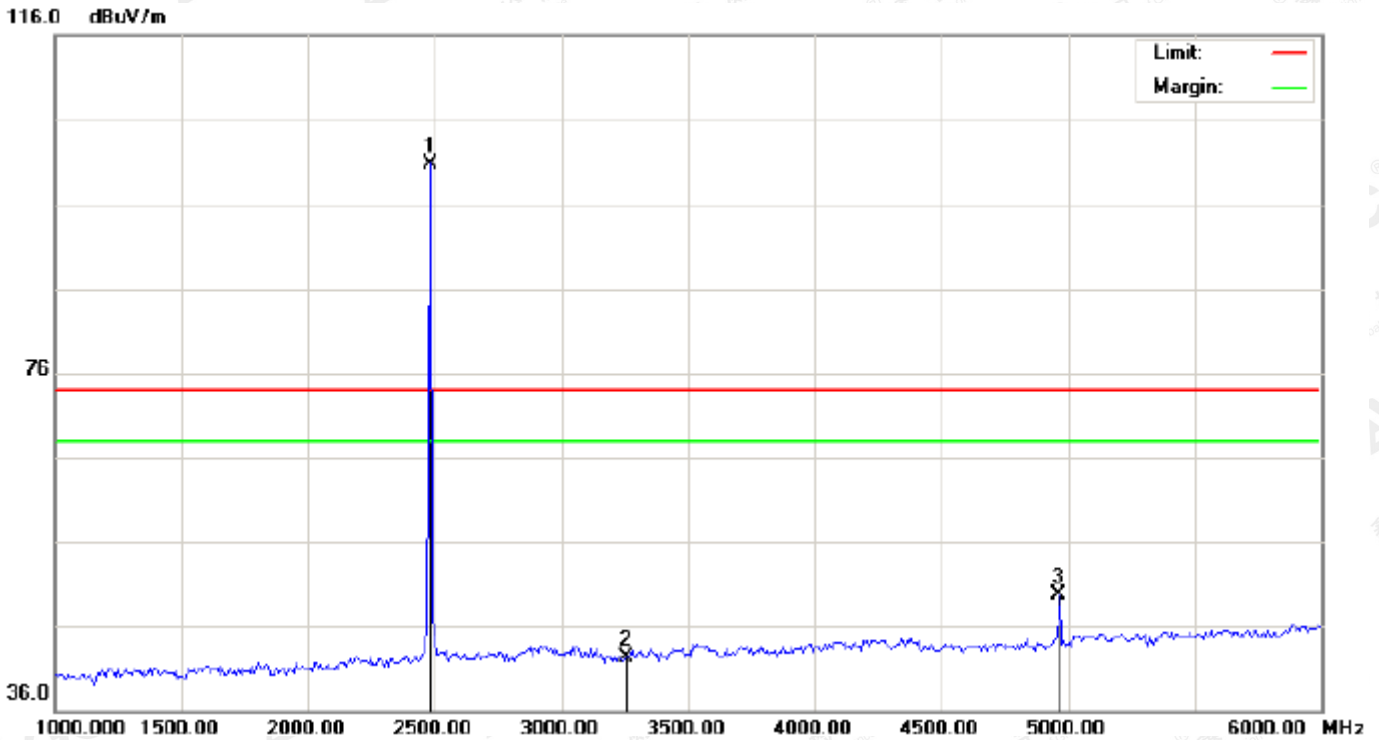

| No. | Mk | Freq. | Reading | Factor | Measurement | Limit | Over | Detector | Antenna | Table | Comment |
|-----|----|----------|---------|--------|-------------|--------|--------|----------|---------|--------|---------|
| | | MHz | dBuV | dB/m | dBuV/m | dBuV/m | dB | | Height | Degree | |
| | | | | | | | | | cm | degree | |
| 1 | * | 2480.000 | 90.31 | 10.41 | 100.72 | 74.00 | 26.72 | peak | | | |
| 2 | | 3256.000 | 30.41 | 11.88 | 42.29 | 74.00 | -31.71 | peak | | | |
| 3 | | 4960.000 | 41.60 | 8.09 | 49.69 | 74.00 | -24.31 | peak | | | |

RESULT: PASS

The results shown in this test report refer only to the sample(s) tested unless otherwise stated and the sample(s) are retained for 30 days only. The document is issued by AGC, this document cannot be reproduced except in full with our prior written permission. The more details and the authenticity of the report will be confirmed at <http://www.agc-cert.com>.

RADIATED EMISSION ABOVE 1GHz (1-10th Harmonics)-HIGH CHANNEL –VERTICAL

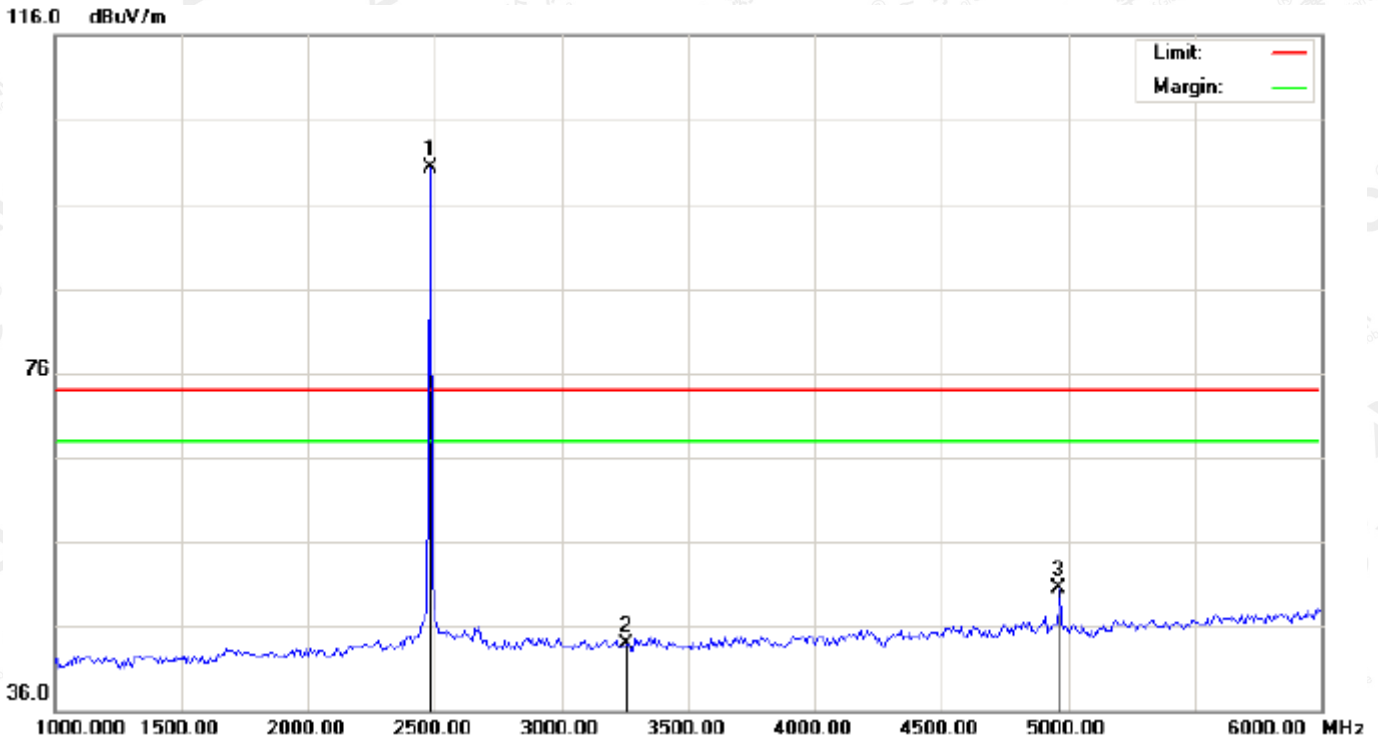

| No. | Mk | Freq. | Reading | Factor | Measurement | Limit | Over | Detector | Antenna | Table | Comment |
|-----|----|----------|---------|--------|-------------|--------|--------|----------|---------|--------|---------|
| | | MHz | dBuV | dB/m | dBuV/m | dBuV/m | dB | | Height | Degree | |
| 1 | * | 2480.000 | 89.82 | 10.41 | 100.23 | 74.00 | 26.23 | peak | | | |
| 2 | | 3259.000 | 31.97 | 11.88 | 43.85 | 74.00 | -30.15 | peak | | | |
| 3 | | 4960.000 | 42.41 | 8.09 | 50.50 | 74.00 | -23.50 | peak | | | |

RESULT: PASS

Note: 6~25GHz at least have 20dB margin. No recording in the test report.

Factor=Antenna Factor+ Cable loss-Amplifier gain, Margin=Measurement-Limit.

The "Factor" value can be calculated automatically by software of measurement system.

The results shown in this test report refer only to the sample(s) tested unless otherwise stated and the sample(s) are retained for 30 days only. The document is issued by AGC, this document cannot be reproduced except in full with our prior written permission. The more details and the authenticity of the report will be confirmed at <http://www.agc-cert.com>.

12. BAND EDGE EMISSION

12.1. MEASUREMENT PROCEDURE

1. Set the EUT Work on the top, the bottom operation frequency individually.
2. Set SPA Start or Stop Frequency=Operation Frequency,
For unrestricted band: RBW=100kHz, VBW=300kHz
For restricted band: RBW=1MHz, VBW=3*RBW
Center frequency =Operation frequency
3. The band edges was measured and recorded.

12.2. TEST SET-UP

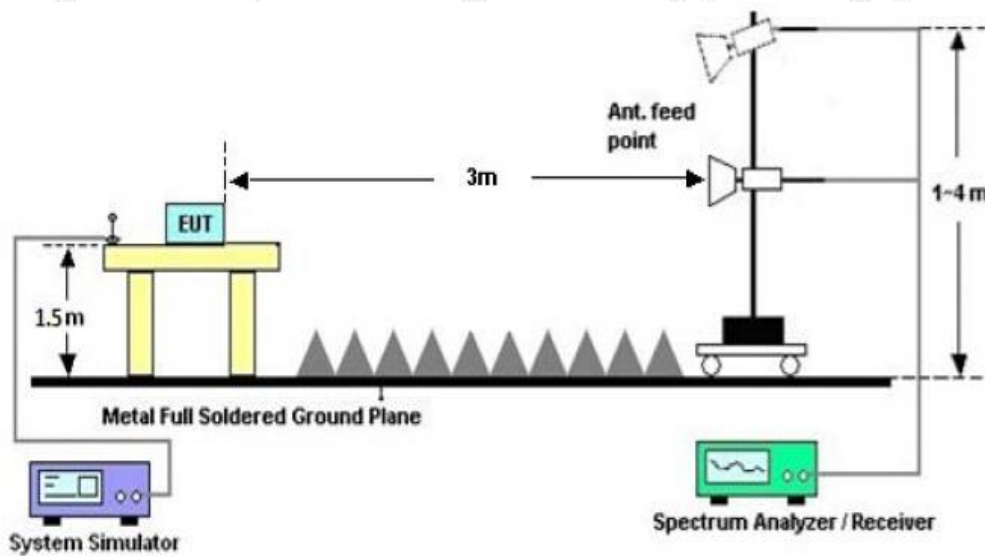

The results shown in this test report refer only to the sample(s) tested unless otherwise stated and the sample(s) are retained for 30 days only. The document is issued by AGC, this document cannot be reproduced except in full with our prior written permission. The more details and the authenticity of the report will be confirmed at <http://www.agc-cert.com>.

12.3. TEST RESULT

(Worst Modulation: 8DPSK)

TEST PLOT OF BAND EDGE FOR LOW CHANNEL (3Mbps)-Horizontal

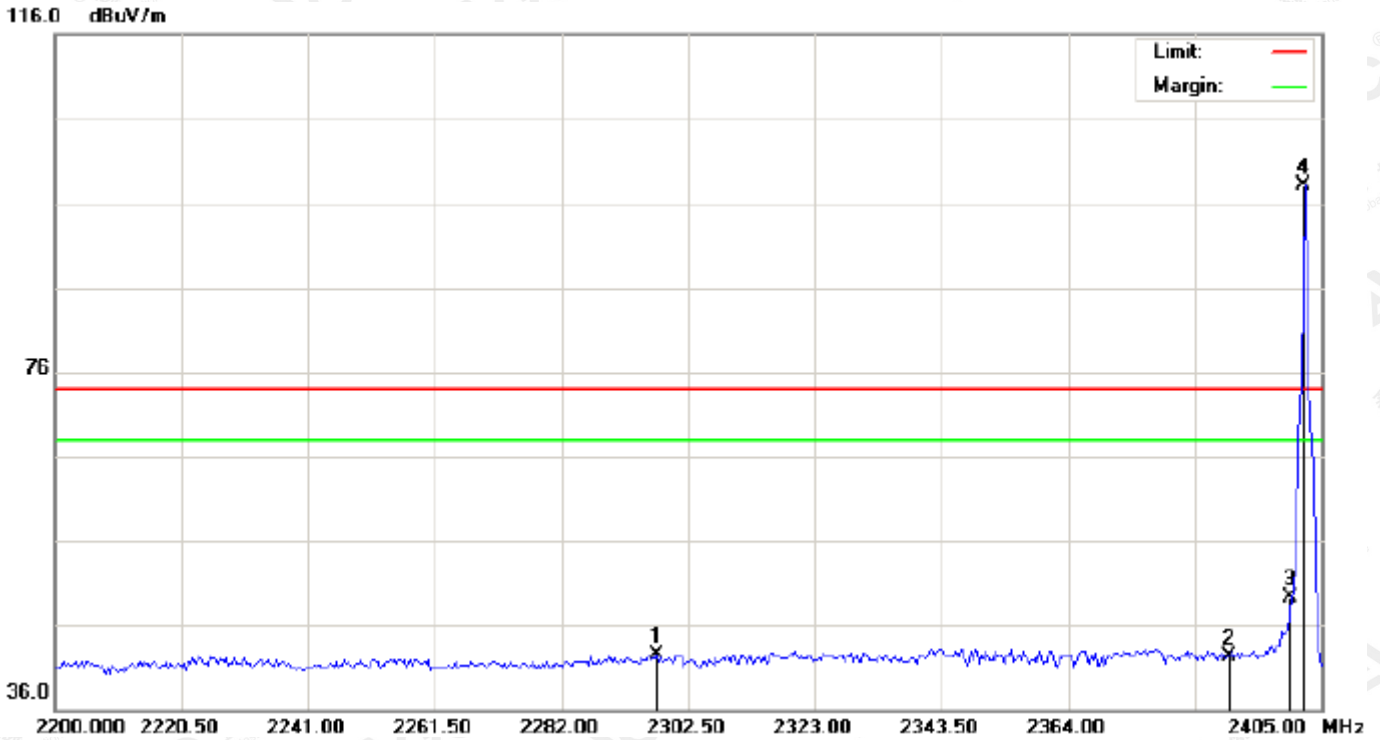

| No. | Mk | Freq. | Reading | Factor | Measurement | Limit | Over | Detector | Antenna | Table | Comment |
|-----|----|----------|---------|--------|-------------|--------|--------|----------|---------|--------|---------|
| | | MHz | dBuV | dB/m | dBuV/m | dBuV/m | dB | | Height | Degree | |
| | | | | | | | | | cm | degree | |
| 1 | | 2297.375 | 32.28 | 10.21 | 42.49 | 74.00 | -31.51 | peak | | | |
| 2 | | 2390.000 | 32.00 | 10.31 | 42.31 | 74.00 | -31.69 | peak | | | |
| 3 | | 2400.000 | 38.97 | 10.32 | 49.29 | 74.00 | -24.71 | peak | | | |
| 4 | * | 2402.000 | 87.72 | 10.32 | 98.04 | 74.00 | 24.04 | peak | | | |

The results shown in this test report refer only to the sample(s) tested unless otherwise stated and the sample(s) are retained for 30 days only. The document is issued by AGC, this document cannot be reproduced except in full with our prior written permission. The more details and the authenticity of the report will be confirmed at <http://www.agc-cert.com>.

TEST PLOT OF BAND EDGE FOR LOW CHANNEL (3Mbps)-Vertical

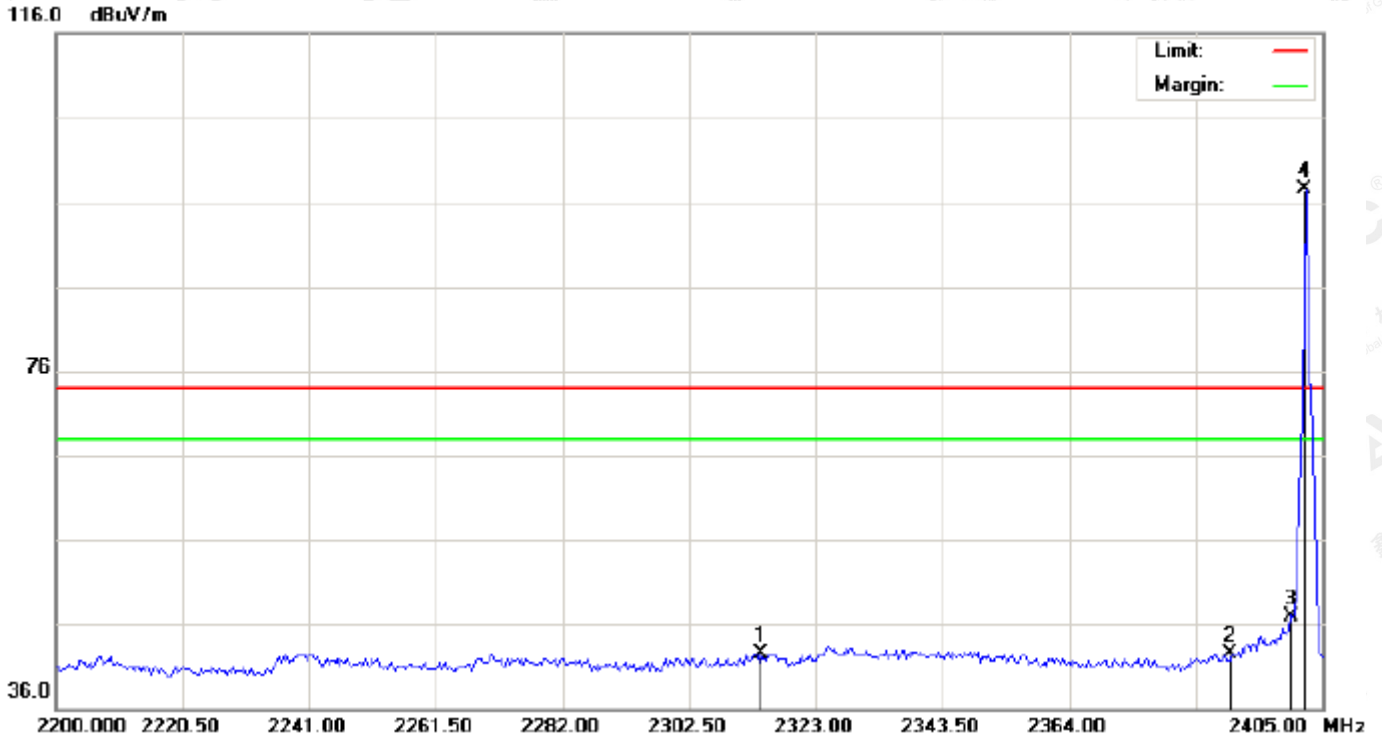

| No. | Mk | Freq. | Reading | Factor | Measurement | Limit | Over | Detector | Antenna | Table | Comment |
|-----|----|----------|---------|--------|-------------|--------|--------|----------|---------|--------|---------|
| | | MHz | dBuV | dB/m | dBuV/m | dBuV/m | dB | | Height | Degree | |
| 1 | | 2314.116 | 32.27 | 10.23 | 42.50 | 74.00 | -31.50 | peak | | | |
| 2 | | 2390.000 | 32.21 | 10.31 | 42.52 | 74.00 | -31.48 | peak | | | |
| 3 | | 2400.000 | 36.56 | 10.32 | 46.88 | 74.00 | -27.12 | peak | | | |
| 4 | * | 2402.000 | 87.09 | 10.32 | 97.41 | 74.00 | 23.41 | peak | | | |

The results shown in this test report refer only to the sample(s) tested unless otherwise stated and the sample(s) are retained for 30 days only. The document is issued by AGC, this document cannot be reproduced except in full with our prior written permission. The more details and the authenticity of the report will be confirmed at <http://www.agc-cert.com>.

TEST PLOT OF BAND EDGE FOR HIGH CHANNEL (3Mbps)-Horizontal

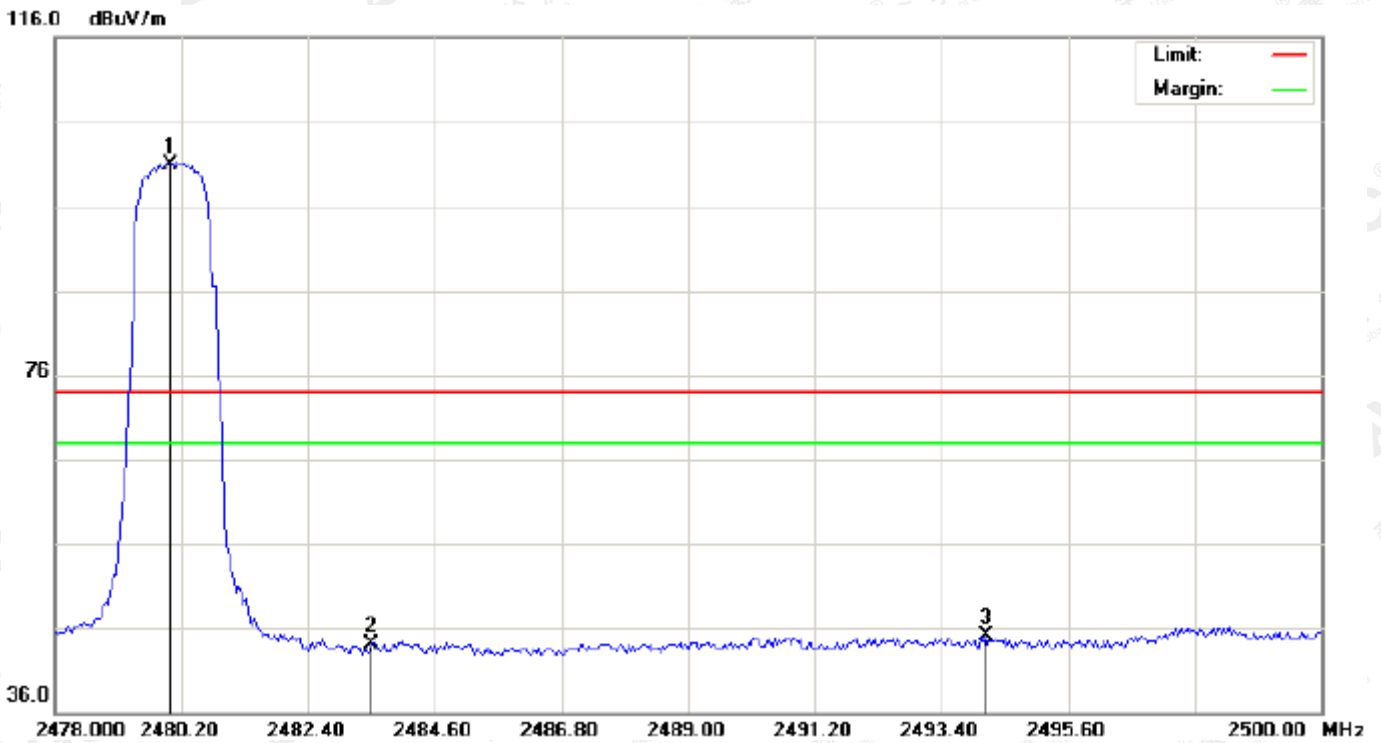

| No. | Mk | Freq. | Reading | Factor | Measurement | Limit | Over | Detector | Antenna | Table | Comment |
|-----|----|----------|---------|--------|-------------|--------|--------|----------|---------|--------|---------|
| | | MHz | dBuV | dB/m | dBuV/m | dBuV/m | dB | | Height | Degree | |
| 1 | * | 2480.000 | 90.42 | 10.41 | 100.83 | 74.00 | 26.83 | peak | | | |
| 2 | | 2483.500 | 33.69 | 10.41 | 44.10 | 74.00 | -29.90 | peak | | | |
| 3 | | 2494.170 | 34.63 | 10.42 | 45.05 | 74.00 | -28.95 | peak | | | |

The results shown in this test report refer only to the sample(s) tested unless otherwise stated and the sample(s) are retained for 30 days only. The document is issued by AGC, this document cannot be reproduced except in full with our prior written permission. The more details and the authenticity of the report will be confirmed at <http://www.agc-cert.com>.

TEST PLOT OF BAND EDGE FOR HIGH CHANNEL (3Mbps)-Vertical

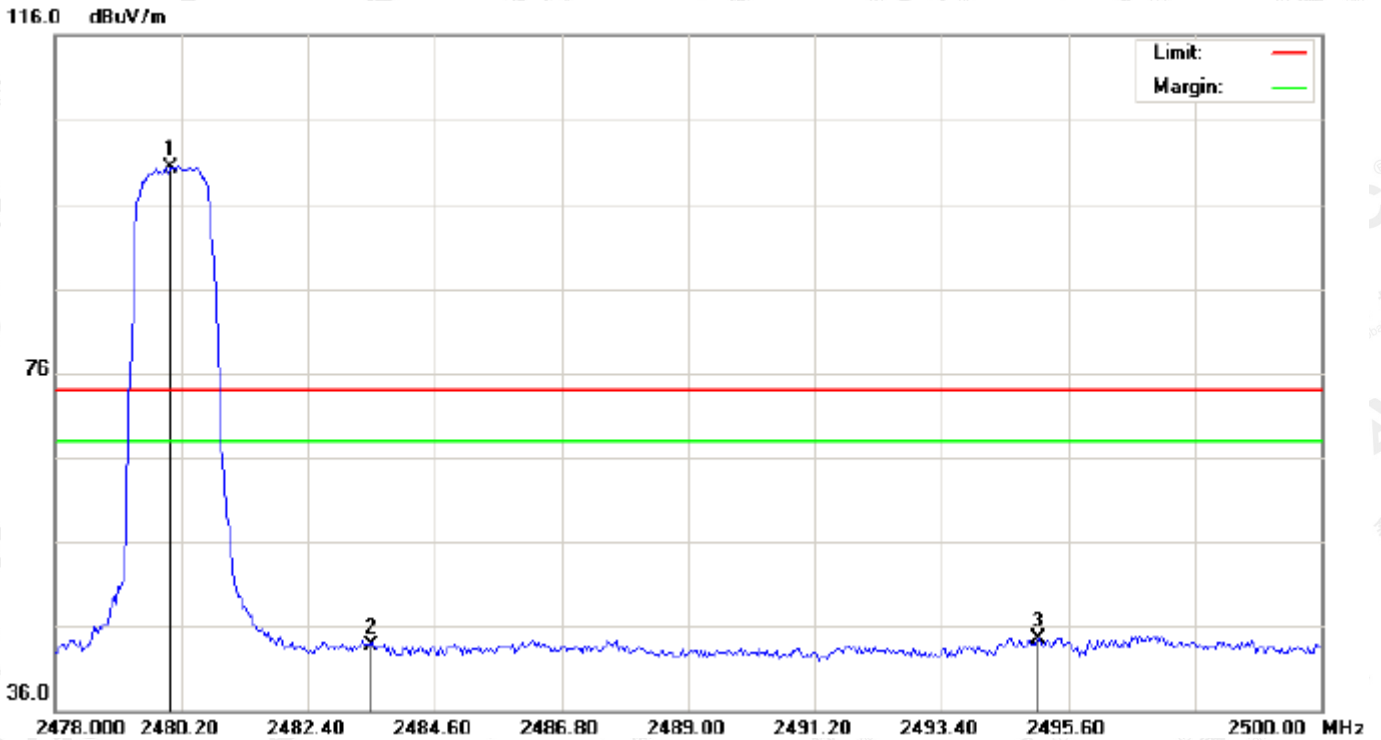

| No. | Mk | Freq. | Reading | Factor | Measurement | Limit | Over | Detector | Antenna Height | Table Degree | Comment |
|-----|----|----------|---------|--------|-------------|--------|--------|----------|----------------|--------------|---------|
| | | MHz | dBuV | dB/m | dBuV/m | dBuV/m | dB | | cm | degree | |
| 1 | * | 2480.000 | 89.85 | 10.41 | 100.26 | 74.00 | 26.26 | peak | | | |
| 2 | | 2483.500 | 33.26 | 10.41 | 43.67 | 74.00 | -30.33 | peak | | | |
| 3 | | 2495.087 | 34.08 | 10.42 | 44.50 | 74.00 | -29.50 | peak | | | |

RESULT: PASS

Note: 1. Factor=Antenna Factor + Cable loss, Margin=Measurement-Limit.

- The "Factor" value can be calculated automatically by software of measurement system.
- Hopping off and Hopping on have been tested and only worst case recorded

The results shown in this test report refer only to the sample(s) tested unless otherwise stated and the sample(s) are retained for 30 days only. The document is issued by AGC, this document cannot be reproduced except in full with our prior written permission. The more details and the authenticity of the report will be confirmed at <http://www.agc-cert.com>.

13. NUMBER OF HOPPING FREQUENCY

13.1. MEASUREMENT PROCEDURE

1. Place the EUT on the table and set it in transmitting mode.
2. Remove the antenna from the EUT and then connect a low RF cable from the antenna port to the spectrum analyzer.
3. Set the spectrum analyzer Start = 2.4GHz Stop = 2.4835GHz
4. Set the Spectrum Analyzer as RBW>=1%span, VBW>=3RBW.

13.2. TEST SETUP (BLOCK DIAGRAM OF CONFIGURATION)

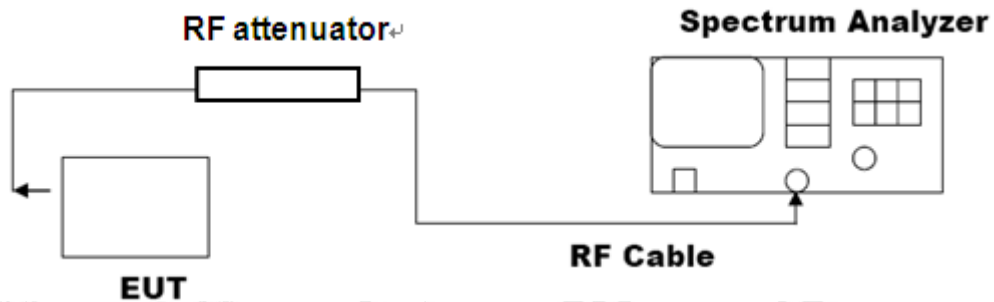

13.3. LIMITS AND MEASUREMENT RESULT

| TOTAL NO. OF HOPPING CHANNEL | LIMIT (NO. OF CH) | MEASUREMENT (NO. OF CH) | RESULT |
|------------------------------|-------------------|-------------------------|--------|
| | >=15 | 79 | PASS |

The results shown in this test report refer only to the sample(s) tested unless otherwise stated and the sample(s) are retained for 30 days only. The document is issued by AGC, this document cannot be reproduced except in full with our prior written permission. The more details and the authenticity of the report will be confirmed at <http://www.agc-cert.com>.

TEST PLOT FOR NO. OF TOTAL CHANNELS

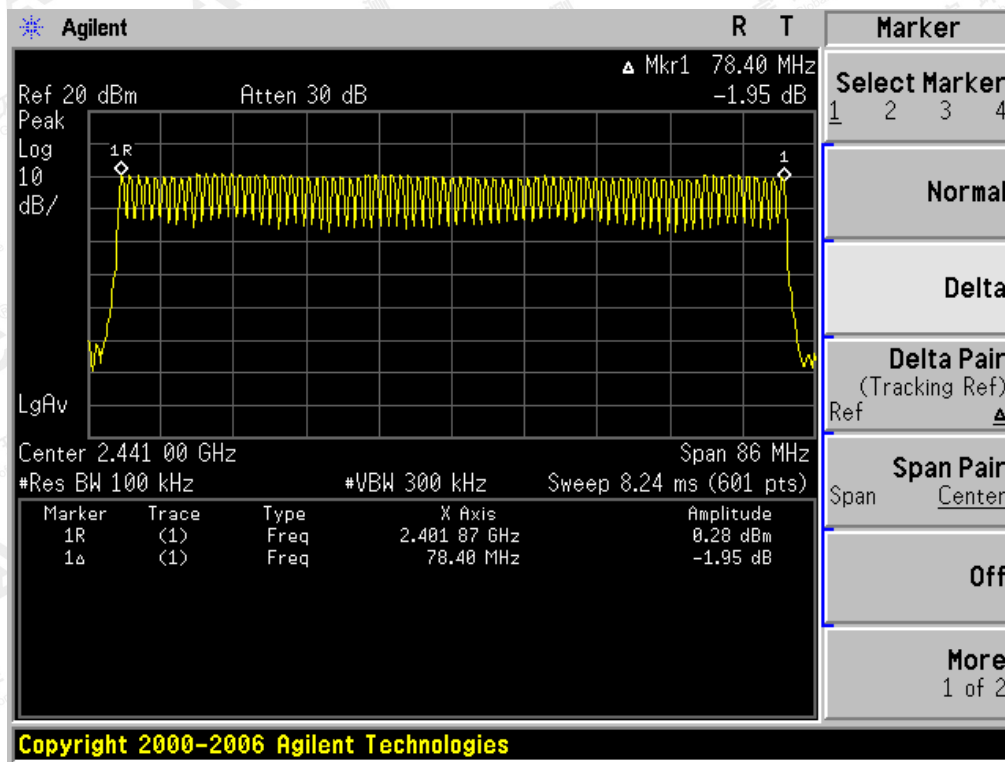

The results shown in this test report refer only to the sample(s) tested unless otherwise stated and the sample(s) are retained for 30 days only. The document is issued by AGC, this document cannot be reproduced except in full with our prior written permission. The more details and the authenticity of the report will be confirmed at <http://www.agc-cert.com>.

14. TIME OF OCCUPANCY (DWELL TIME)

14.1. MEASUREMENT PROCEDURE

1. Place the EUT on the table and set it in transmitting mode
2. Remove the antenna from the EUT and then connect a low RF cable from the antenna port to the spectrum analyzer.
3. Set Span = zero span, centered on a hopping channel
4. Set the spectrum analyzer as RBW=1MHz, VBW>=RBW, Span = 0 Hz

14.2. TEST SETUP (BLOCK DIAGRAM OF CONFIGURATION)

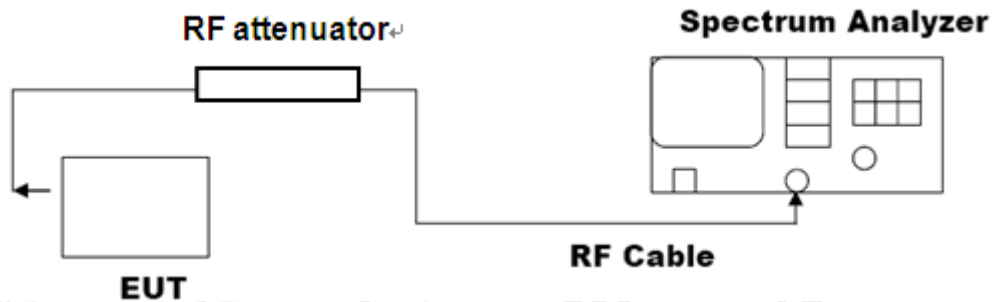

14.3. LIMITS AND MEASUREMENT RESULT

The Worst Case (3Mbps)

| Channel | Time of Pulse for DH5 (ms) | Period Time (s) | Sweep Time (ms) | Limit (ms) |
|---------|----------------------------|-----------------|-----------------|------------|
| Low | 2.870 | 31.6 | 306.13 | 400 |
| Middle | 2.842 | 31.6 | 303.15 | 400 |
| High | 2.842 | 31.6 | 303.15 | 400 |

Low Channel Time

$$2.870 * (1600/6) / 79 * 31.6 = 306.13 \text{ms}$$

Middle Channel Time

$$2.842 * (1600/6) / 79 * 31.6 = 303.15 \text{ms}$$

High Channel Time

$$2.842 * (1600/6) / 79 * 31.6 = 303.15 \text{ms}$$

The results shown in this test report refer only to the sample(s) tested unless otherwise stated and the sample(s) are retained for 30 days only. The document is issued by AGC, this document cannot be reproduced except in full with our prior written permission. The more details and the authenticity of the report will be confirmed at <http://www.agc-cert.com>.

TEST PLOT OF LOW CHANNEL

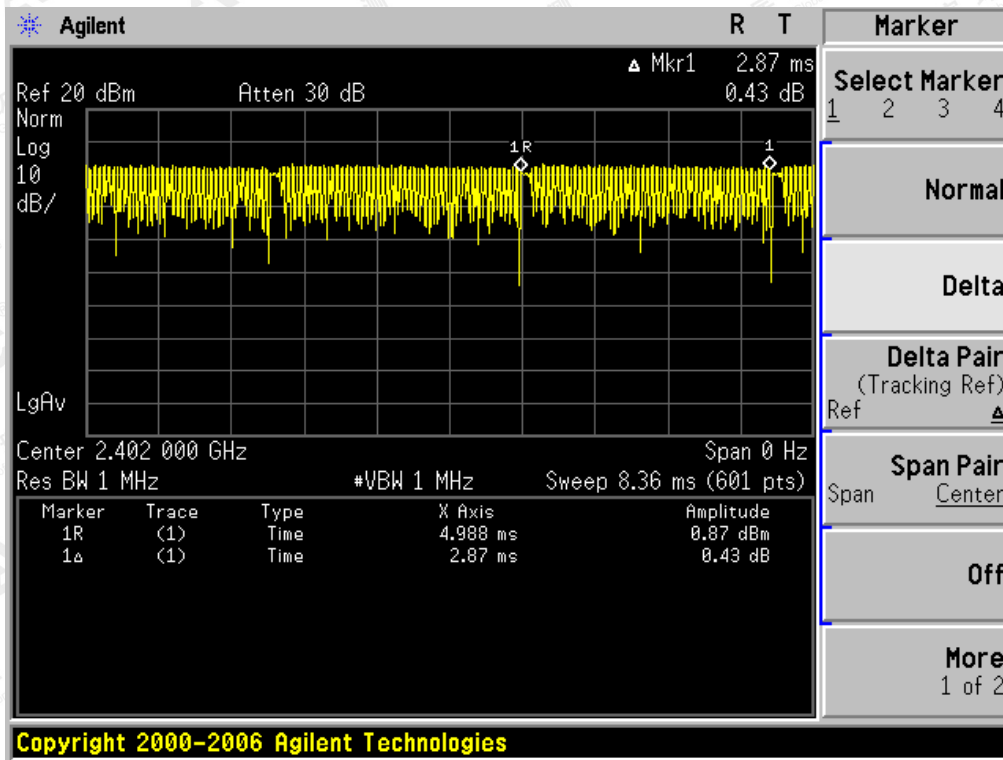

TEST PLOT OF MIDDLE CHANNEL

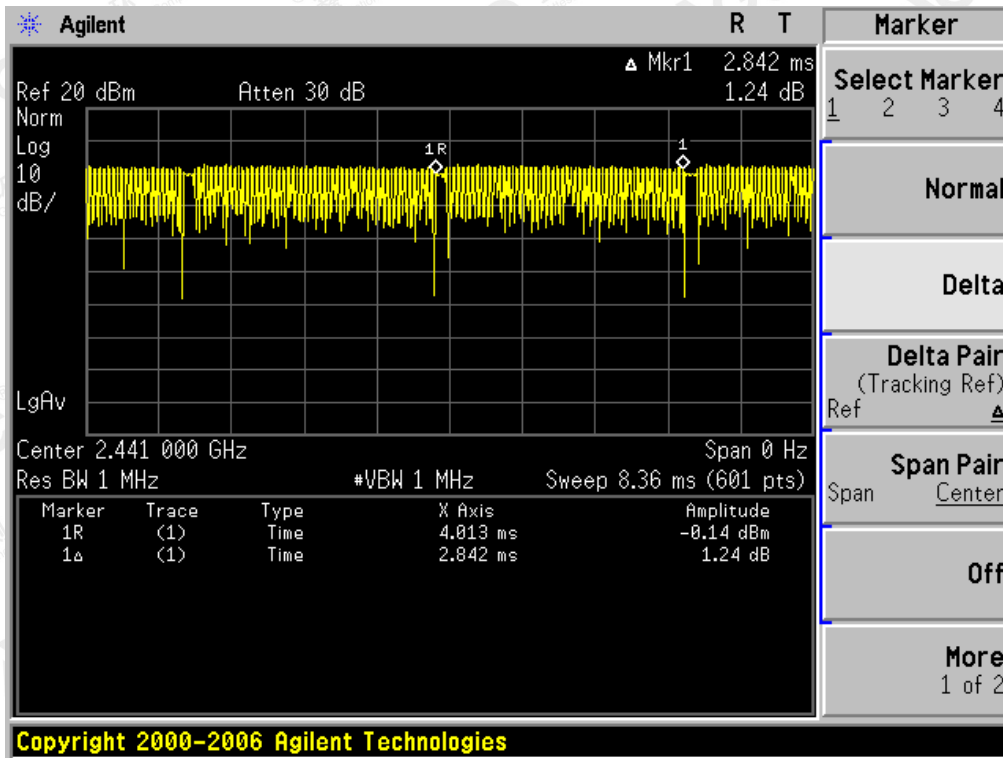

The results shown in this test report refer only to the sample(s) tested otherwise stated and the sample(s) are retained for 30 days only. The document is issued by AGC, this document cannot be reproduced except in full with our prior written permission. The more details and the authenticity of the report will be confirmed at <http://www.agc-cert.com>.

TEST PLOT OF HIGH CHANNEL

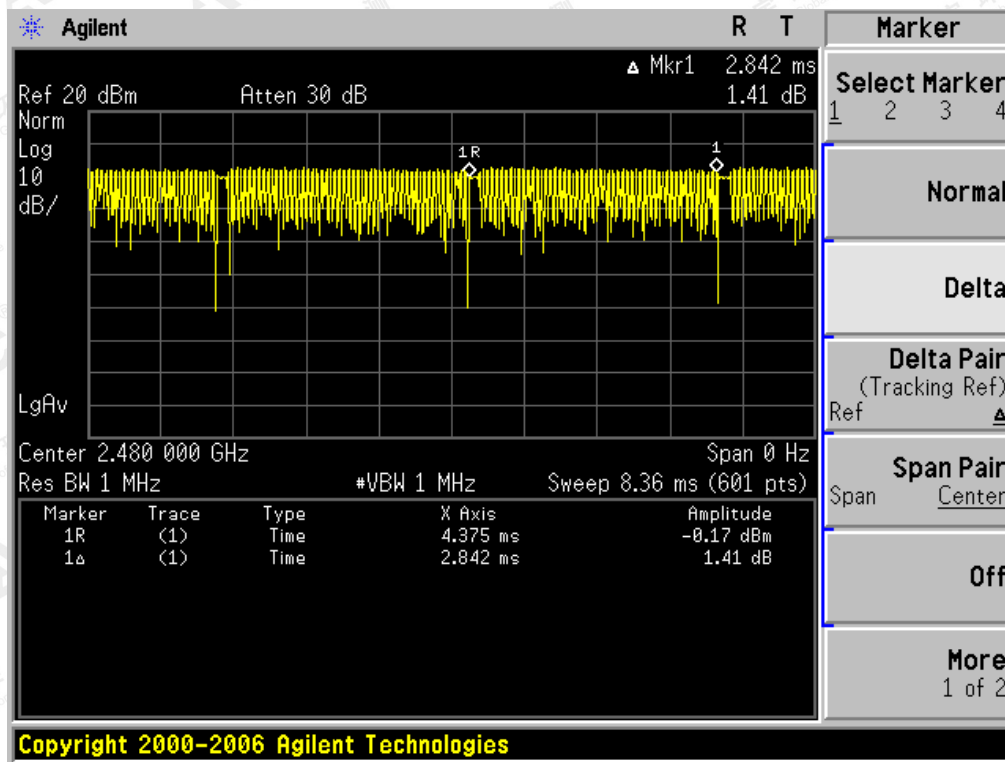

The results shown in this test report refer only to the sample(s) tested unless otherwise stated and the sample(s) are retained for 30 days only. The document is issued by AGC, this document cannot be reproduced except in full with our prior written permission. The more details and the authenticity of the report will be confirmed at <http://www.agc-cert.com>.

15. FREQUENCY SEPARATION

15.1. MEASUREMENT PROCEDURE

1. Place the EUT on the table and set it in transmitting mode
2. Remove the antenna from the EUT and then connect a low RF cable from the antenna port to the spectrum analyzer
3. Set Span = wide enough to capture the peaks of two adjacent channels Resolution (or IF) Bandwidth (RBW) \geq 1% of the span Video (or Average) Bandwidth (VBW) \geq RBW; Sweep = auto; Detector function = peak; Trace = max hold

15.2. TEST SETUP (BLOCK DIAGRAM OF CONFIGURATION)

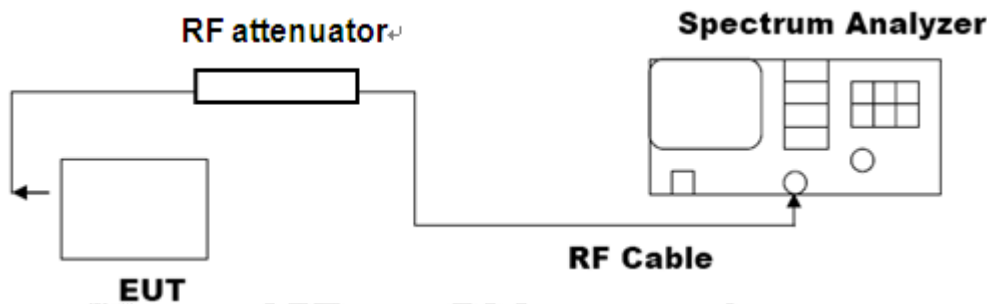

15.3. LIMITS AND MEASUREMENT RESULT

| CHANNEL | CHANNEL SEPARATION | LIMIT | RESULT |
|-----------|--------------------|-------------------------------|--------|
| | KHz | KHz | |
| CH00-CH01 | 1000 | \geq 25 KHz or 2/3 20 dB BW | Pass |

The results shown in this test report refer only to the sample(s) tested unless otherwise stated and the sample(s) are retained for 30 days only. The document is issued by AGC, this document cannot be reproduced except in full with our prior written permission. The more details and the authenticity of the report will be confirmed at <http://www.agc-cert.com>.

TEST PLOT FOR FREQUENCY SEPARATION (3Mbps)

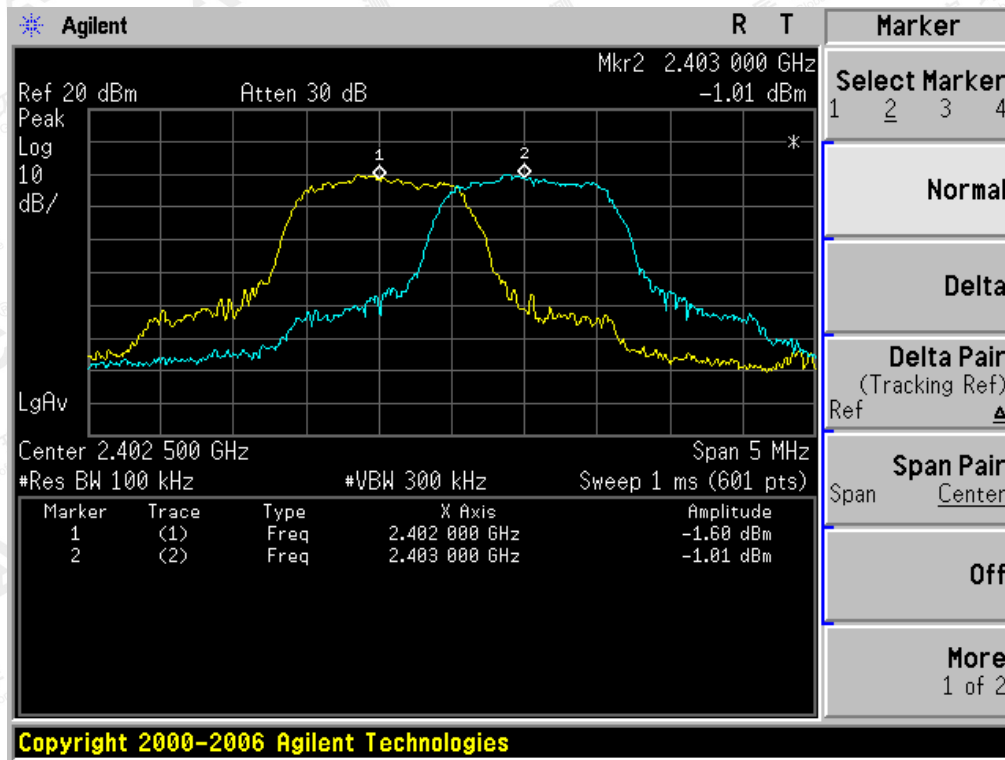

The results shown in this test report refer only to the sample(s) tested unless otherwise stated and the sample(s) are retained for 30 days only. The document is issued by AGC, this document cannot be reproduced except in full with our prior written permission. The more details and the authenticity of the report will be confirmed at <http://www.agc-cert.com>.

16. LINE CONDUCTED EMISSION TEST

16.1. LIMITS OF LINE CONDUCTED EMISSION TEST

| Frequency | Maximum RF Line Voltage | |
|---------------|-------------------------|----------------|
| | Q.P.(dBuV) | Average(dBuV) |
| 150kHz~500kHz | 66-56 | 56-46 |
| 500kHz~5MHz | 56 | 46 |
| 5MHz~30MHz | 60 | 50 |

Note:

1. The lower limit shall apply at the transition frequency.
2. The limit decreases linearly with the logarithm of the frequency in the range 0.15 MHz to 0.50 MHz.

16.2. BLOCK DIAGRAM OF LINE CONDUCTED EMISSION TEST

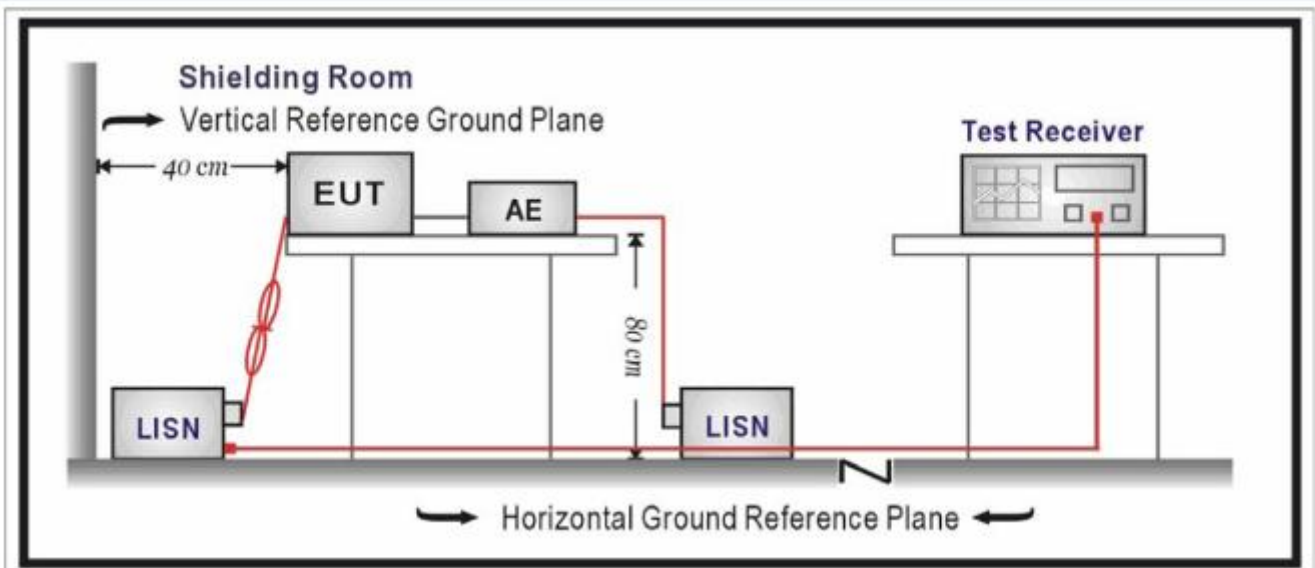

The results shown in this test report refer only to the sample(s) tested unless otherwise stated and the sample(s) are retained for 30 days only. The document is issued by AGC, this document cannot be reproduced except in full with our prior written permission. The more details and the authenticity of the report will be confirmed at <http://www.agc-cert.com>.

16.3. PRELIMINARY PROCEDURE OF LINE CONDUCTED EMISSION TEST

1. The equipment was set up as per the test configuration to simulate typical actual usage per the user's manual. When the EUT is a tabletop system, a wooden table with a height of 0.8 meters is used and is placed on the ground plane as per ANSI C63.10 (see Test Facility for the dimensions of the ground plane used). When the EUT is a floor-standing equipment, it is placed on the ground plane which has a 3-12 mm non-conductive covering to insulate the EUT from the ground plane.
2. Support equipment, if needed, was placed as per ANSI C63.10.
3. All I/O cables were positioned to simulate typical actual usage as per ANSI C63.10.
4. All support equipments received AC120V/60Hz power from a LISN, if any.
5. The EUT received power by adapter or PC received 120V/60Hz power by a LISN.
6. The test program was started. Emissions were measured on each current carrying line of the EUT using a spectrum Analyzer / Receiver connected to the LISN powering the EUT. The LISN has two monitoring points: Line 1 (Hot Side) and Line 2 (Neutral Side). Two scans were taken: one with Line 1 connected to Analyzer / Receiver and Line 2 connected to a 50 ohm load; the second scan had Line 1 connected to a 50 ohm load and Line 2 connected to the Analyzer / Receiver.
7. Analyzer / Receiver scanned from 150 kHz to 30MHz for emissions in each of the test modes.
8. During the above scans, the emissions were maximized by cable manipulation.
9. The test mode(s) were scanned during the preliminary test.

Then, the EUT configuration and cable configuration of the above highest emission level were recorded for reference of final testing.

16.4. FINAL PROCEDURE OF LINE CONDUCTED EMISSION TEST

1. EUT and support equipment was set up on the test bench as per step 2 of the preliminary test.
2. A scan was taken on both power lines, Line 1 and Line 2, recording at least the six highest emissions. Emission frequency and amplitude were recorded into a computer in which correction factors were used to calculate the emission level and compare reading to the applicable limit. If EUT emission level was less -2dB to the A.V. limit in Peak mode, then the emission signal was re-checked using Q.P and Average detector.
3. The test data of the worst case condition(s) was reported on the Summary Data page.

The results shown in this test report refer only to the sample(s) tested unless otherwise stated and the sample(s) are retained for 30 days only. The document is issued by AGC, this document cannot be reproduced except in full with our prior written permission. The more details and the authenticity of the report will be confirmed at <http://www.agc-cert.com>.

16.5. TEST RESULT OF LINE CONDUCTED EMISSION TEST

By adapter(worst case)

Line Conducted Emission Test Line 1-L

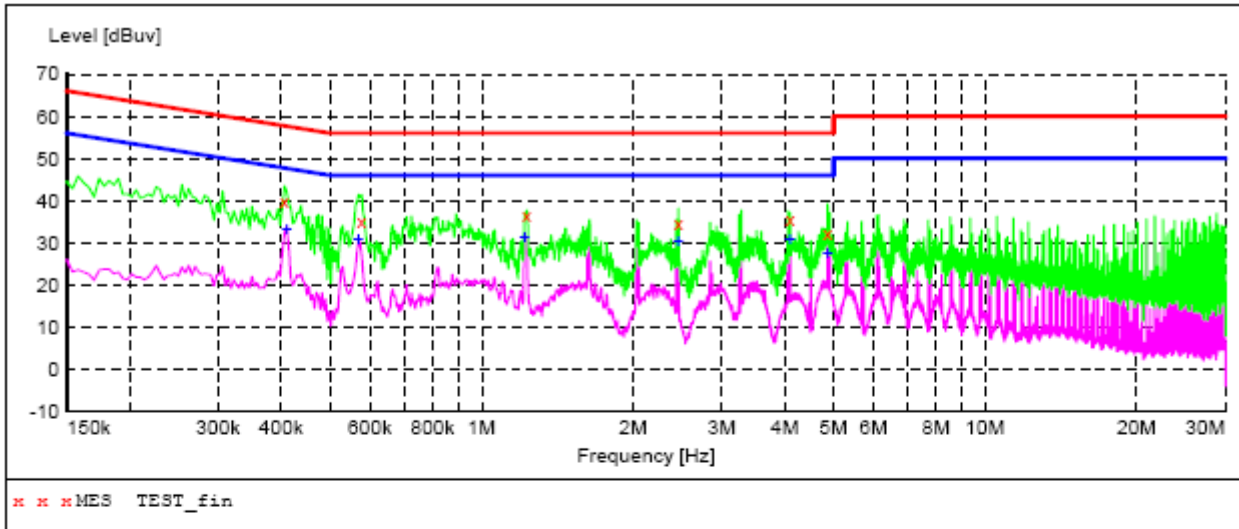

MEASUREMENT RESULT: "TEST_fin"

2018/4/27 19:46

| Frequency MHz | Level dBuV | Transd dB | Limit dBuV | Margin dB | Detector | Line | PE |
|------------------|---------------|--------------|---------------|--------------|----------|------|-----|
| 0.406000 | 39.70 | 10.1 | 58 | 18.0 | QP | L1 | FLO |
| 0.578000 | 35.30 | 10.1 | 56 | 20.7 | QP | L1 | FLO |
| 1.230000 | 36.40 | 10.2 | 56 | 19.6 | QP | L1 | FLO |
| 2.458000 | 34.70 | 10.0 | 56 | 21.3 | QP | L1 | FLO |
| 4.098000 | 35.60 | 10.2 | 56 | 20.4 | QP | L1 | FLO |
| 4.870000 | 32.30 | 10.3 | 56 | 23.7 | QP | L1 | FLO |

MEASUREMENT RESULT: "TEST_fin2"

2018/4/27 19:46

| Frequency MHz | Level dBuV | Transd dB | Limit dBuV | Margin dB | Detector | Line | PE |
|------------------|---------------|--------------|---------------|--------------|----------|------|-----|
| 0.410000 | 33.40 | 10.1 | 48 | 14.2 | AV | L1 | FLO |
| 0.570000 | 30.80 | 10.1 | 46 | 15.2 | AV | L1 | FLO |
| 1.218000 | 31.40 | 10.2 | 46 | 14.6 | AV | L1 | FLO |
| 2.458000 | 30.30 | 10.0 | 46 | 15.7 | AV | L1 | FLO |
| 4.098000 | 30.60 | 10.2 | 46 | 15.4 | AV | L1 | FLO |
| 4.870000 | 27.30 | 10.3 | 46 | 18.7 | AV | L1 | FLO |

The results shown in this test report refer only to the sample(s) tested unless otherwise stated and the sample(s) are retained for 30 days only. The document is issued by AGC, this document cannot be reproduced except in full with our prior written permission. The more details and the authenticity of the report will be confirmed at <http://www.agc-cert.com>.

Line Conducted Emission Test Line 2-N

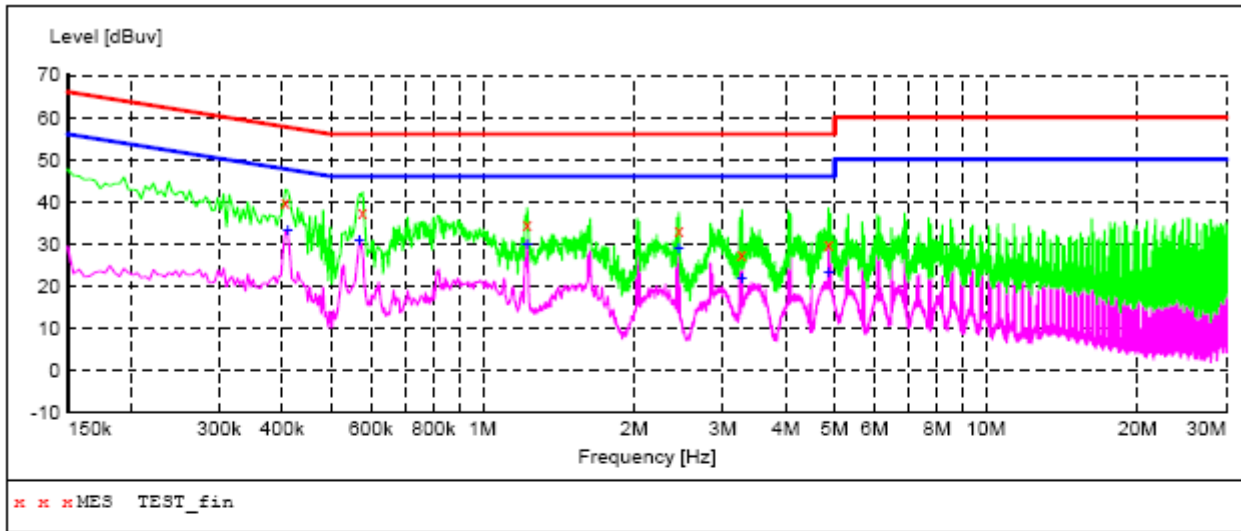

MEASUREMENT RESULT: "TEST_fin"

2018/4/27 19:42

| Frequency MHz | Level dBuV | Transd dB | Limit dBuV | Margin dB | Detector | Line | PE |
|---------------|------------|-----------|------------|-----------|----------|------|-----|
| 0.406000 | 39.90 | 10.1 | 58 | 17.8 | QP | N | FLO |
| 0.578000 | 37.50 | 10.1 | 56 | 18.5 | QP | N | FLO |
| 1.226000 | 34.60 | 10.2 | 56 | 21.4 | QP | N | FLO |
| 2.454000 | 33.20 | 10.0 | 56 | 22.8 | QP | N | FLO |
| 3.270000 | 27.30 | 10.0 | 56 | 28.7 | QP | N | FLO |
| 4.862000 | 29.90 | 10.3 | 56 | 26.1 | QP | N | FLO |

MEASUREMENT RESULT: "TEST_fin2"

2018/4/27 19:42

| Frequency MHz | Level dBuV | Transd dB | Limit dBuV | Margin dB | Detector | Line | PE |
|---------------|------------|-----------|------------|-----------|----------|------|-----|
| 0.410000 | 33.10 | 10.1 | 48 | 14.5 | AV | N | FLO |
| 0.570000 | 30.80 | 10.1 | 46 | 15.2 | AV | N | FLO |
| 1.226000 | 29.80 | 10.2 | 46 | 16.2 | AV | N | FLO |
| 2.454000 | 28.80 | 10.0 | 46 | 17.2 | AV | N | FLO |
| 3.270000 | 21.60 | 10.0 | 46 | 24.4 | AV | N | FLO |
| 4.862000 | 23.30 | 10.3 | 46 | 22.7 | AV | N | FLO |

The results shown in this test report refer only to the sample(s) tested unless otherwise stated and the sample(s) are retained for 30 days only. The document is issued by AGC, this document cannot be reproduced except in full with our prior written permission. The more details and the authenticity of the report will be confirmed at <http://www.agc-cert.com>.

APPENDIX A: PHOTOGRAPHS OF TEST SETUP
FCC LINE CONDUCTED EMISSION TEST SETUP



FCC RADIATED EMISSION TEST SETUP

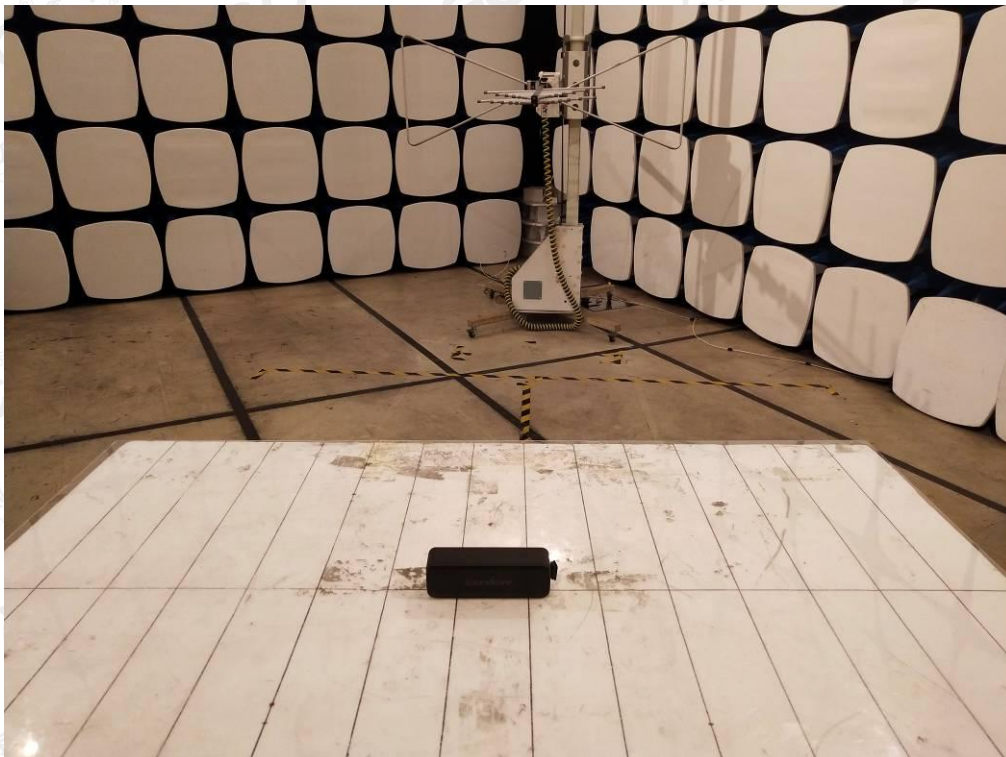

The results shown in this test report refer only to the sample(s) tested unless otherwise stated and the sample(s) are retained for 30 days only. The document is issued by AGC, this document cannot be reproduced except in full with our prior written permission. The more details and the authenticity of the report will be confirmed at <http://www.agc-cert.com>.

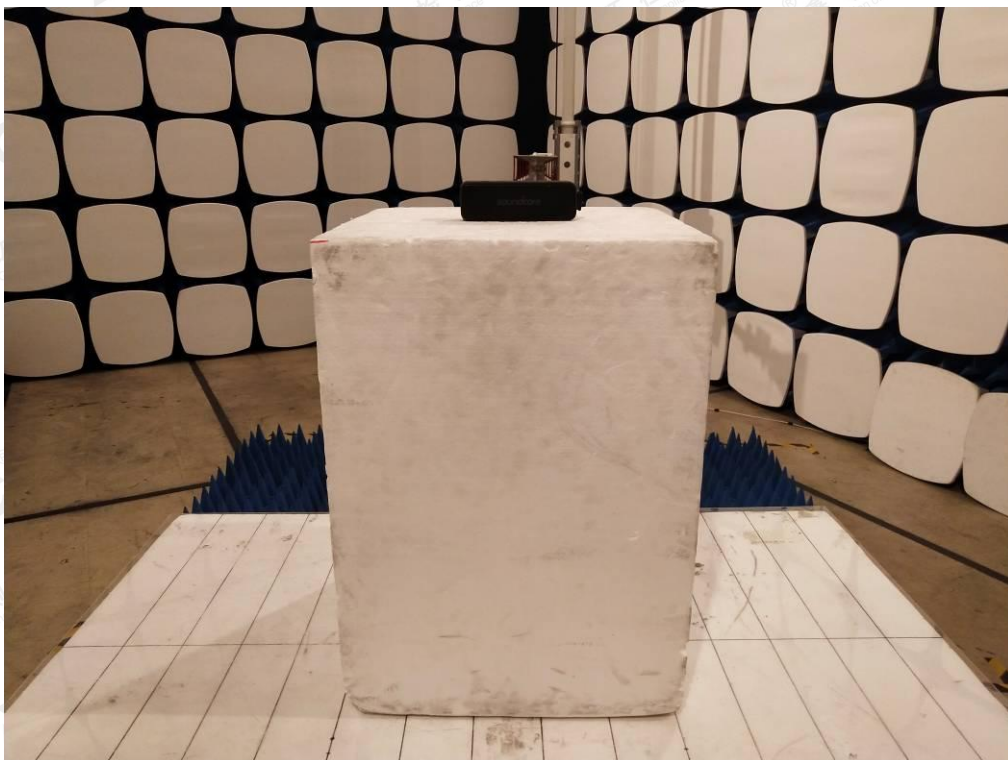
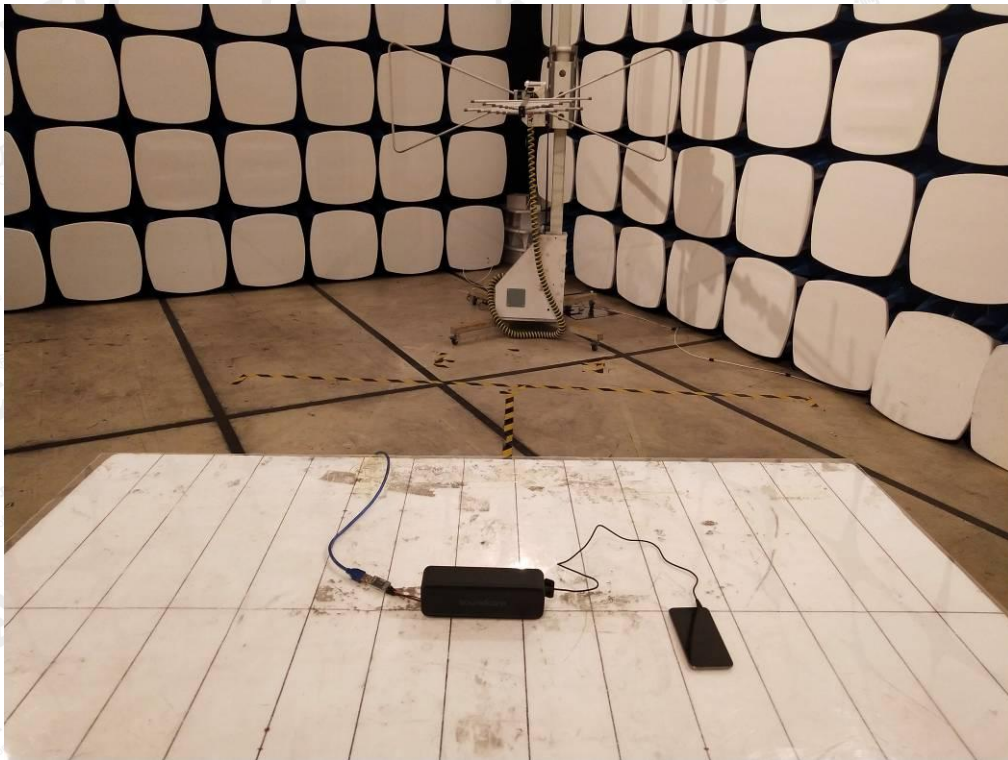

The results shown in this test report refer only to the sample(s) tested otherwise stated and the sample(s) are retained for 30 days only. The document is issued by AGC, this document cannot be reproduced except in full with our prior written permission. The more details and the authenticity of the report will be confirmed at <http://www.agc-cert.com>.

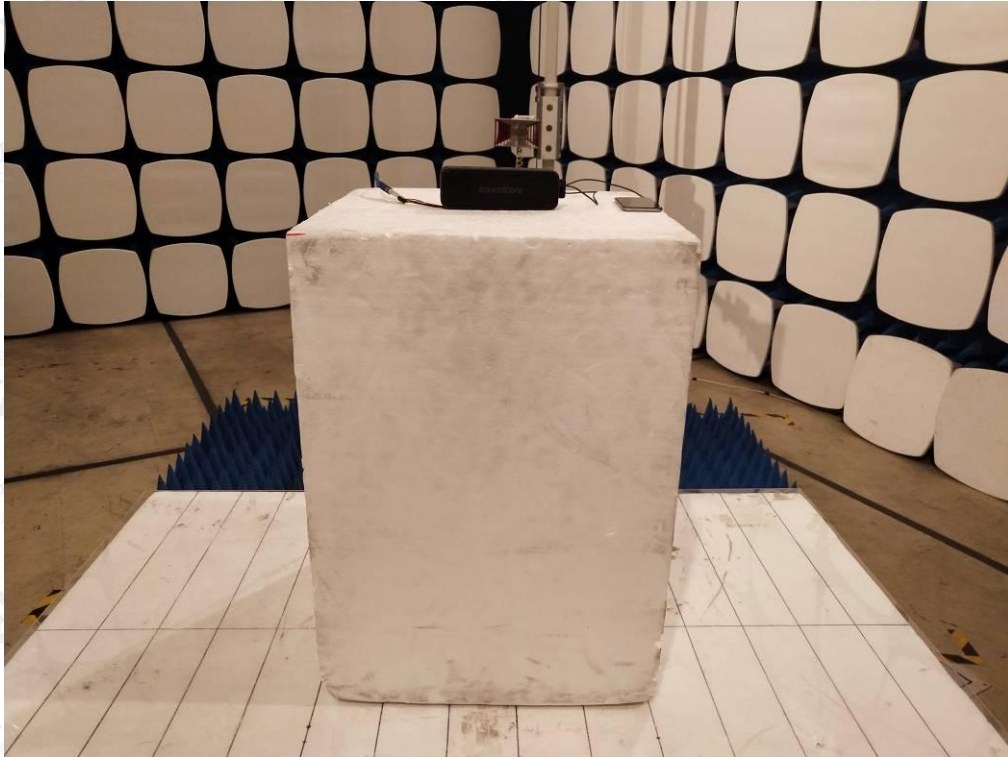

The results shown in this test report refer only to the sample(s) tested unless otherwise stated and the sample(s) are retained for 30 days only. The document is issued by AGC, this document cannot be reproduced except in full with our prior written permission. The more details and the authenticity of the report will be confirmed at <http://www.agc-cert.com>.

APPENDIX B: PHOTOGRAPHS OF EUT
ALL VIEW OF EUT



TOP VIEW OF EUT



The results shown in this test report refer only to the sample(s) tested unless otherwise stated and the sample(s) are retained for 30 days only. The document is issued by AGC, this document cannot be reproduced except in full with our prior written permission. The more details and the authenticity of the report will be confirmed at <http://www.agc-cert.com>.

BOTTOM VIEW OF EUT



FRONT VIEW OF EUT



The results shown in this test report refer only to the sample(s) tested unless otherwise stated and the sample(s) are retained for 30 days only. The document is issued by AGC, this document cannot be reproduced except in full with our prior written permission. The more details and the authenticity of the report will be confirmed at <http://www.agc-cert.com>.

BACK VIEW OF EUT

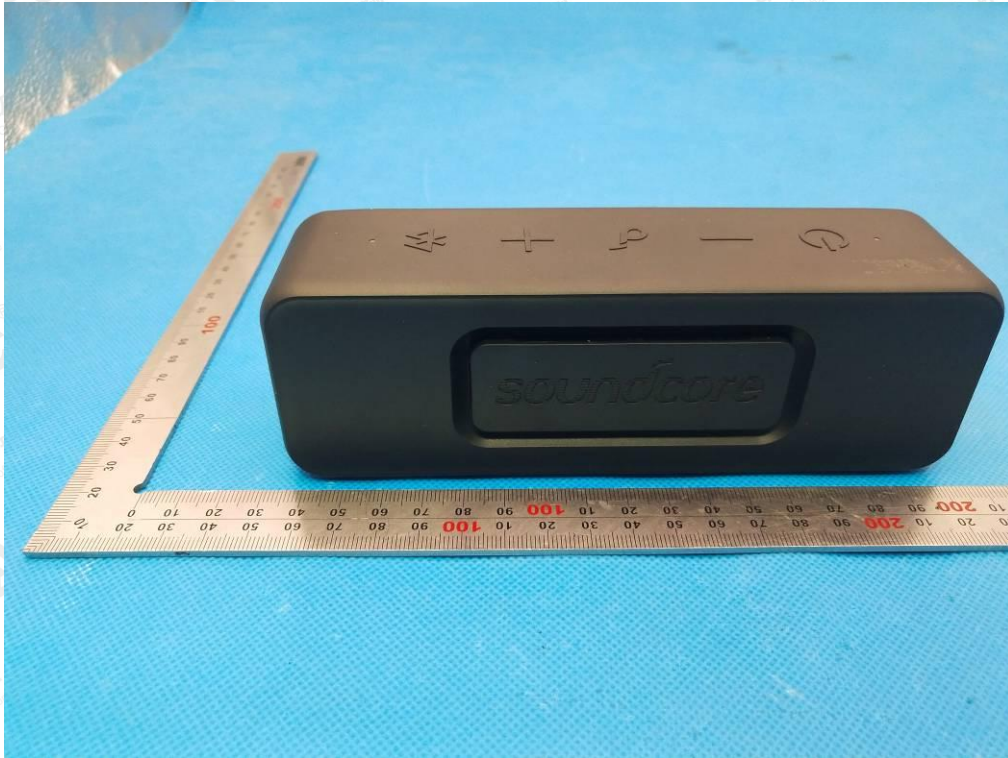

LEFT VIEW OF EUT

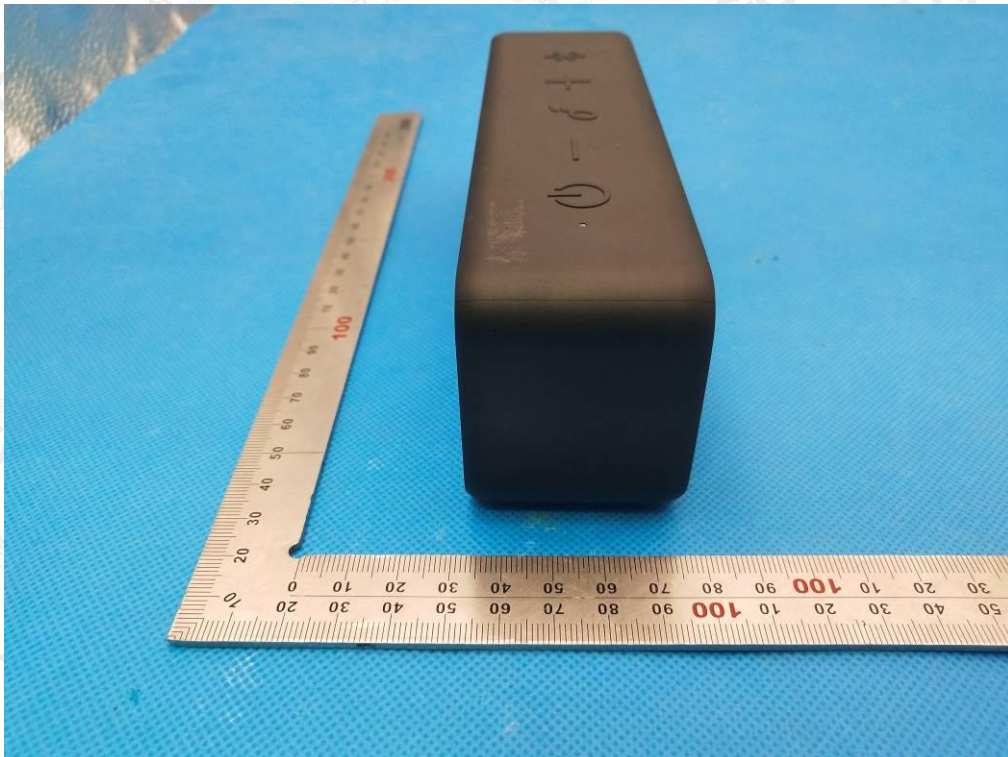

The results shown in this test report refer only to the sample(s) tested unless otherwise stated and the sample(s) are retained for 30 days only. The document is issued by AGC, this document cannot be reproduced except in full with our prior written permission. The more details and the authenticity of the report will be confirmed at <http://www.agc-cert.com>.

RIGHT VIEW OF EUT



VIEW OF EUT (PORT)



The results shown in this test report refer only to the sample(s) tested unless otherwise stated and the sample(s) are retained for 30 days only. The document is issued by AGC, this document cannot be reproduced except in full with our prior written permission. The more details and the authenticity of the report will be confirmed at <http://www.agc-cert.com>.

OPEN VIEW OF EUT



VIEW OF BATTERY

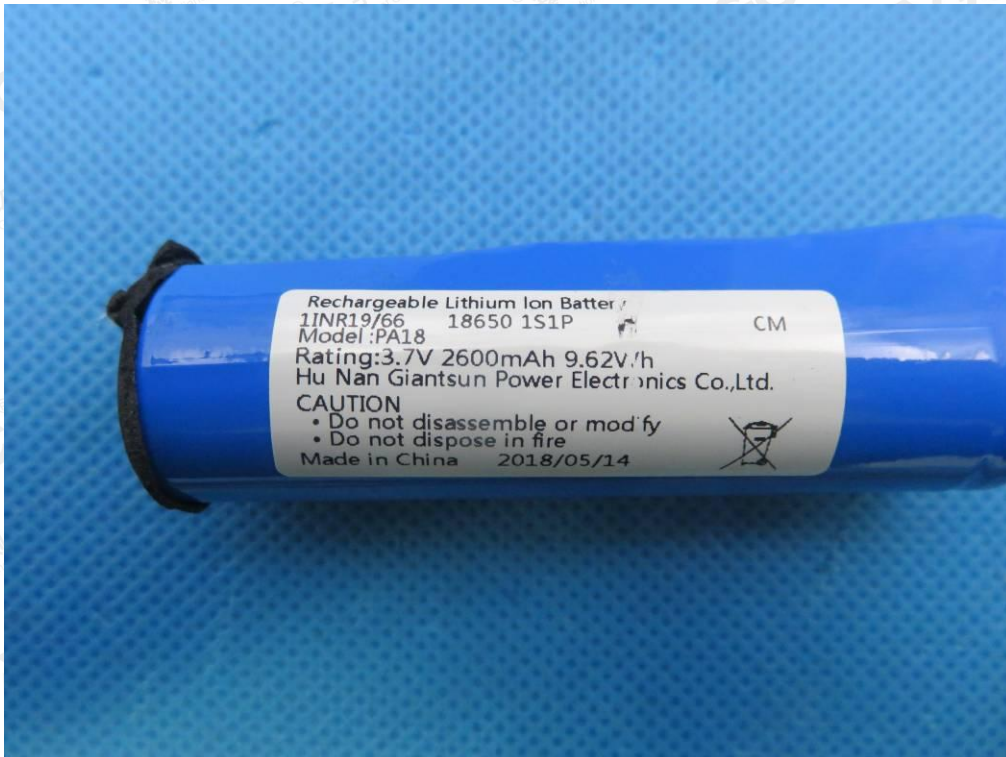

The results shown in this test report refer only to the sample(s) tested unless otherwise stated and the sample(s) are retained for 30 days only. The document is issued by AGC, this document cannot be reproduced except in full with our prior written permission. The more details and the authenticity of the report will be confirmed at <http://www.agc-cert.com>.

INTERNAL VIEW OF EUT-1

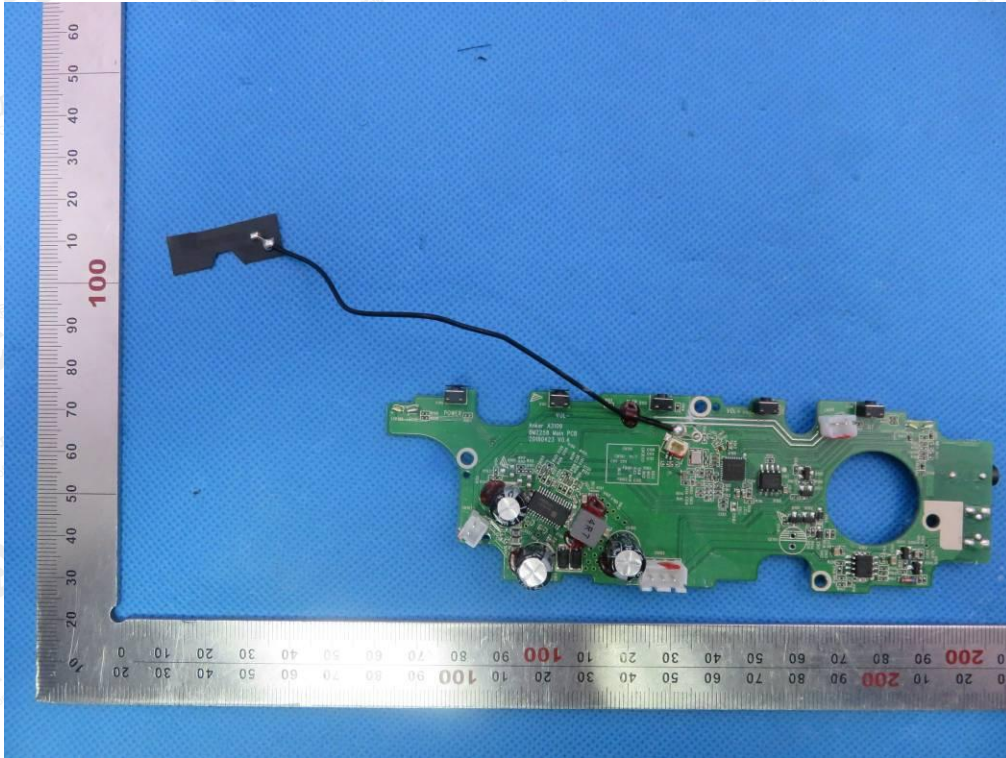

INTERNAL VIEW OF EUT-2

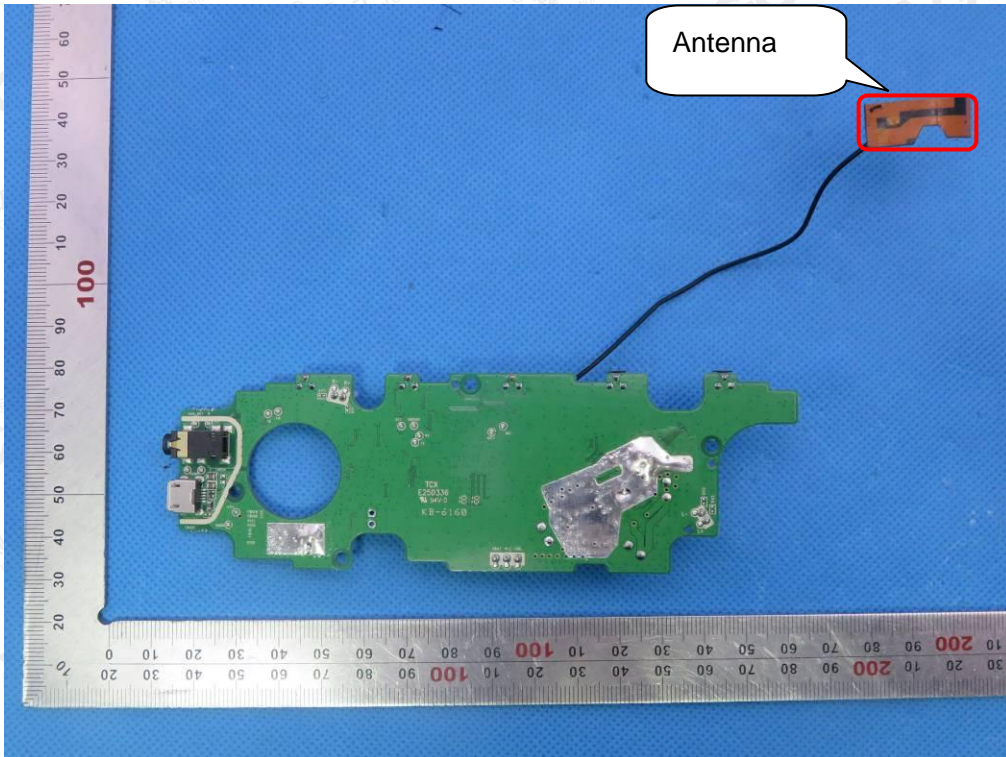

The results shown in this test report refer only to the sample(s) tested unless otherwise stated and the sample(s) are retained for 30 days only. The document is issued by AGC, this document cannot be reproduced except in full with our prior written permission. The more details and the authenticity of the report will be confirmed at <http://www.agc-cert.com>.

INTERNAL VIEW OF EUT-3

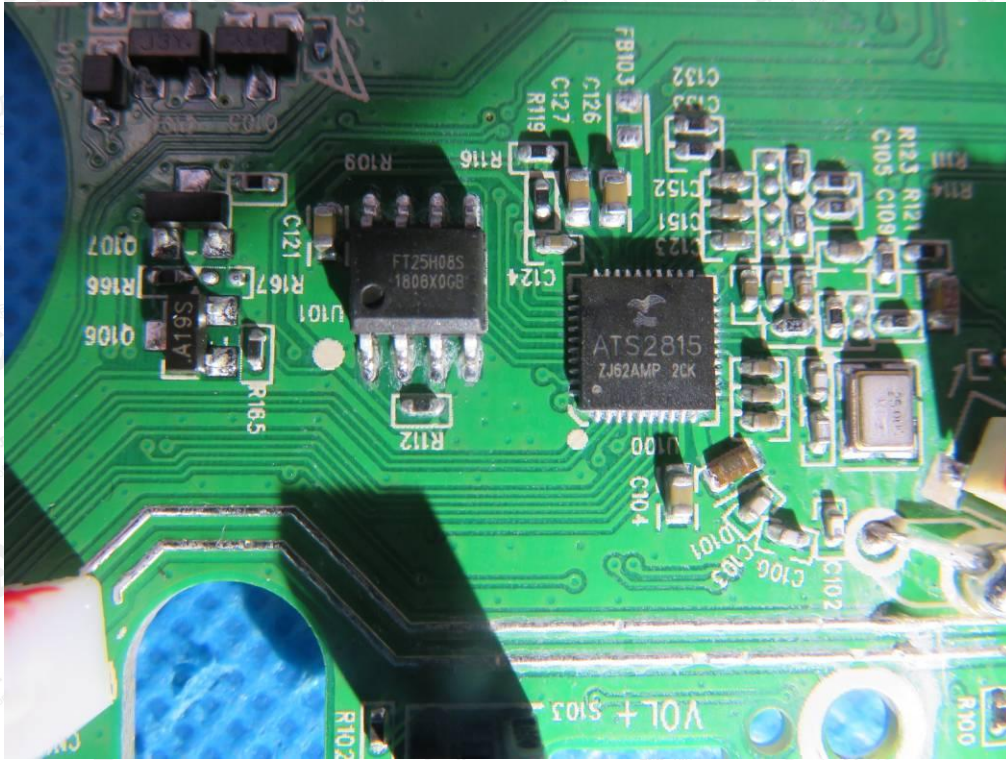

----END OF REPORT----

The results shown in this test report refer only to the sample(s) tested unless otherwise stated and the sample(s) are retained for 30 days only. The document is issued by AGC, this document cannot be reproduced except in full with our prior written permission. The more details and the authenticity of the report will be confirmed at <http://www.agc-cert.com>.