



湖南炬神电子有限公司

HUNAN GIANTSUN POWER ELECTRONICS CO., LTD

湖南郴州有色金属产业园区台湾工业园第 16、17 幢

电话(TEL): 0735-2668666

传真(FAX): 0735-2668000

共 5 页

规格承认书

Specification For Approval

收旧（作废）承认书	
GSP 料号	
版本	
日期	

版本 REV: _____

专案编码 (Case No.) : _____

炬神料号 (GSP Parts No.) : _____ 10801-0045

制造商名称/型号(Name/Model): A11 单线圈发射模组 A11 single coil launch

Moudle _____

元件规格(Components Spec.): A11 单线圈发射模组 A11 single coil launch

Moudle _____

制造商(简称)(Manufacturer): _____ 聚源

供应商(简称)(Supplier): _____ 聚源

承认书编号(No. of Approved): _____

承认日期(Date of Approved): _____

发行部门 Issue Departm ent (文管中心)Docum ent Control Center	承认部门 Accreditation Department					
	主管批准 Supervisor approval	审核 Check				拟制 Prepared
		环 保 environ ment pr otection <input type="checkbox"/>	安 规 Safety regulati ons <input type="checkbox"/>	电 子 Electro nic <input type="checkbox"/>	机 构 instituti on <input type="checkbox"/>	

	条件 接 收 Condi tional accepta nce <input type="checkbox"/>				
	接 收 accepta nce <input type="checkbox"/>				
<p>1. 如有任何变更，须于事前联系，取得承认后方可变更；</p> <p>2. 相关单位需建档保存，条件接收前提见检验报告；</p> <p>3. 如无特殊说明，收旧前一版本时，须将内部及供应商的承认书料号全部收旧。</p> <p>1. If there are any changes, prior contact must be made and approval obtained before making any changes;</p> <p>2. Relevant units need to establish archives for preservation, and the conditions for acceptance can be found in the inspection report;</p> <p>3. Unless otherwise specified, when replacing the previous version, all internal and supplier recognized part numbers must be replaced.</p>					

管理 NO.: GSP-3GC-163-001 A/2

产品型号: Model Number	A11 单线圈发射模组	客户料号: Customer P / N	10801-0045
	A11 single coil launch Moudle	供应商料号: Supplier P / N	18.00540

一, 外观与尺寸 (Appearance Size) : (单位/mm)

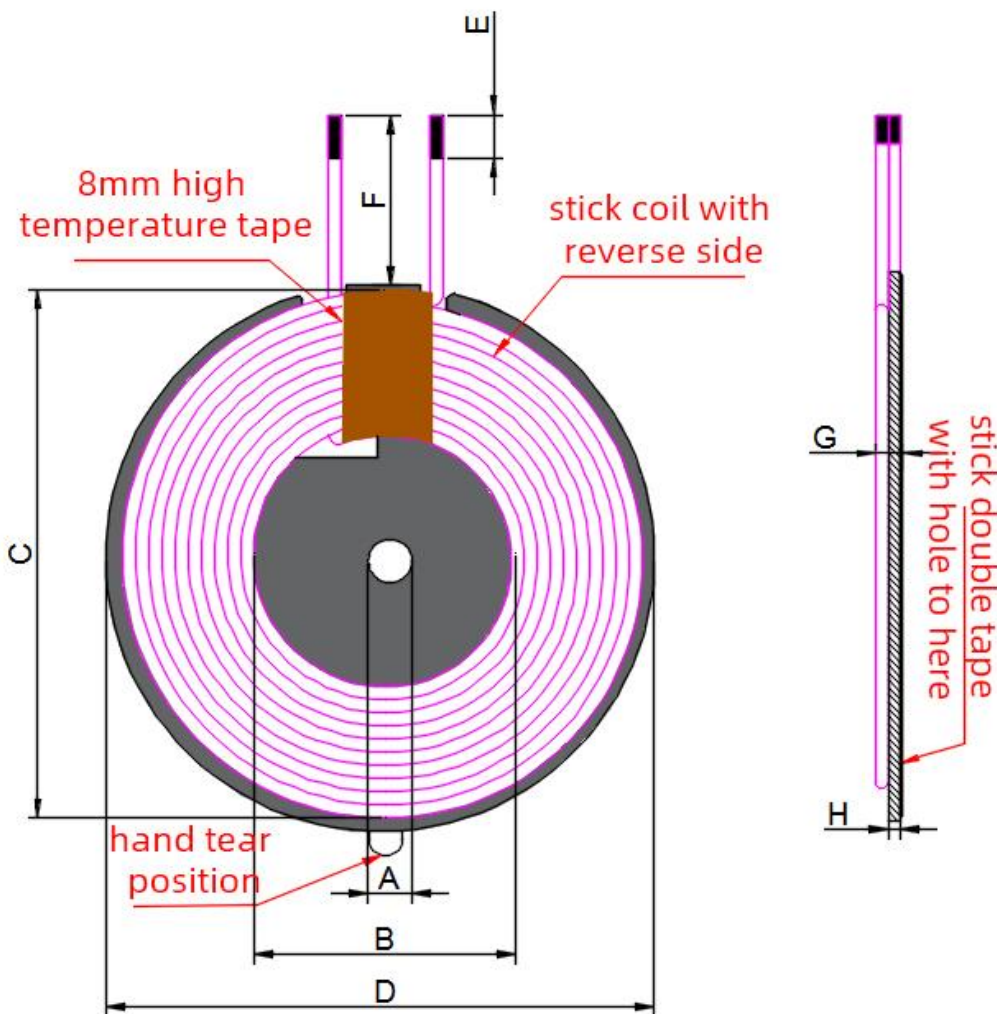

A	5.3±0.3
B	20.5±0.5
C	43MAX
D	44±1
E	3.5±1.5
F	10±2
G	2.6MAX Fix tape position
H	0.8±0.2
I	
J	
K	
L	
M	
N	
O	
P	
Q	
R	
S	
T	
U	
V	
W	
X	
Y	
Z	

二，原理图（Schematic Diagram）：

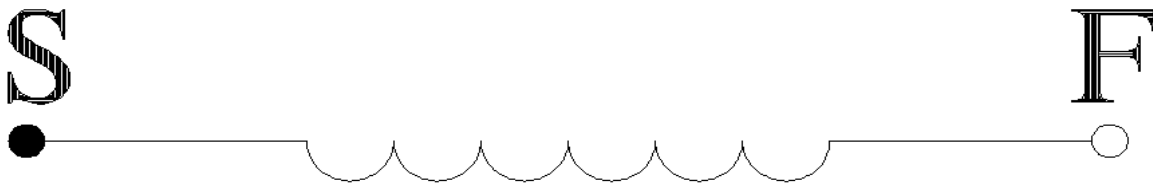

三，绕线参数（Winding Parameters）：

绕组 Winding	开始 Start	结束 Finish	圈数 Turns	线径 Line Diameter	绕线方式 Winding Way	绕线方向 Winding Direction	层数&圈数 Layer&Circle
	S	F	10TS	0.08*105P	单层密绕 Single layer close-packed wound	逆时针 anticlockwise	1层 layer/10TS

四，电气特性（Electrical Characteristics）：

项目 Item	端子 Terminal	测试条件 Test Conditions	测试仪器 Test Instrument	参数 Parameter	单位 Unit	数值 Numerical Value
电感 inductance	S-F	100KHz/1.00V/100Ω	1062 电桥 Electronic Bridge	Inductance @100KHz/1V	μH	6.3μH±10%
电阻 resist	S-F	100KHz/1.00V/100Ω	1062 电桥 Electronic Bridge	RS@100KHz/1V	mΩ	60MAX

ance						
Q 值 Q vaule	S-F	100KHz/1.00V/100Ω	1062 电桥 Electronic Bridge	Q@100KHz/1V		70MIN

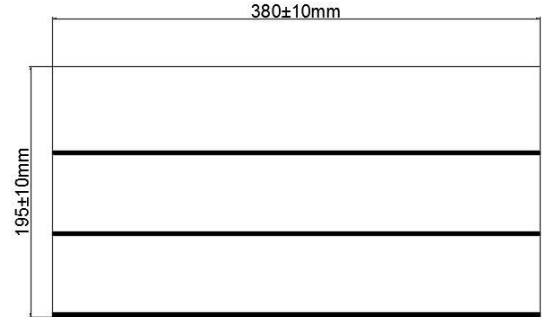
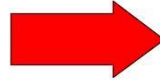
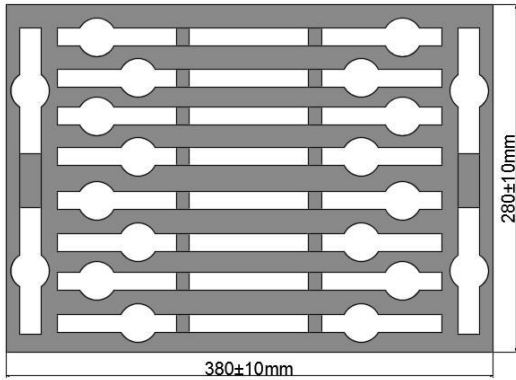

1. EPE size:38*28*6cm
2. Each EPE has 45 cells,6pcs per cell,total 270pcs

Each box is packed with 3 layers of EPE,The EPE is Separated by cardboard



1. Each layer of pearl cotton can hold 270 pcs of products;
2. Each box can contain 3 layers of pearl cotton, which can contain 280 products

产品 Product	单层数量 Single layer quantity	层数/箱 Layer/Box	总数/箱 Total/Box	重量 Weight
A11-G44	270pcs	3层	810pcs	

材料清单

Material List

客户料号: Customer P / N		10801-0045		制造商料号: Supplier P / N		18.00540	
序号 No.	材料名称 Material Name	材料规格 Material Specification	材料代号 Material Code	制造商 Manufacturer			
1	自粘丝包线 self-bonded oil enamelled wire	0.08*105P	01.00139				
2	无铅锡条 lead-free tin	高温 High temperature	05.00058				
3	胶水 glue	树脂胶	05.00001				
4	高温胶带 High temperature tape	宽 width 8mm	05.00023				
5	双槽带孔硬磁片 Hard magnets with double trough hole	G44*5.3*0.8mm	02.00003				
6	双面胶 Double tape	43*5*0.08mm	05.00020				
7	纸板 cardboard	378*270mm	04.00020				
8	包装盒 packing	390*280*47mm	04.00029				
9	纸箱 carton	400*300*190mm	04.00008				
10							
11							
12							
13							
14							

