

Model Number	A11	Customer P / N	A25M1
		Supplier P / N	

一, Appearance Size: (unit/mm)

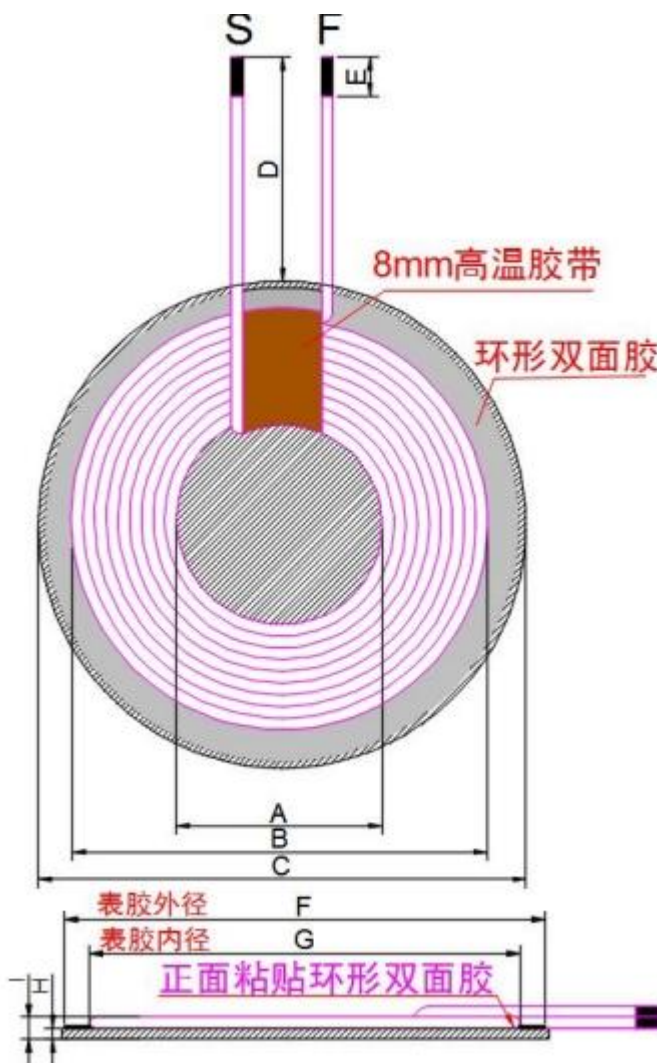

A	20.5±0.5
B	43.5±1
C	50±1
D	10±1
E	3.5±1.5
F	49.5±0.5
G	43±0.5
H	1.0±0.2
I	2.5MAX
J	
K	
L	
M	
N	
O	
P	
Q	
R	
S	
T	
U	
V	
W	
X	
Y	
Z	

二, Schematic Diagram:

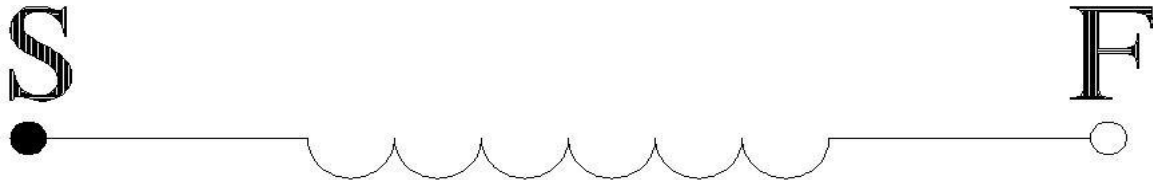

三, Winding Parameters:

Winding	Start	Finish	Turns	Line Diameter	Winding Way	Winding Direction	Layer&Circle
	S	F	10TS	0.08*105P	Single layer close-packed wound	anticlockwise	1layer/10TS

四, Electrical Characteristics:

Item	Terminal	Test Conditions	Test Instrument	Parameter	Unit	Numerical Value
induc tance	S-F	100KHz/1.00V/100Ω	1062 electrical-bridge	Inductance @100KHz/1V	μH	6.3μH±10%
resist ance	S-F	100KHz/1.00V/100Ω	1062 electrical-bridge	@100KHz/1V	mΩ	65MAX
Q Vaule	S-F	100KHz/1.00V/100Ω	1062 electrical-bridge	@100KHz/1V		70MIN

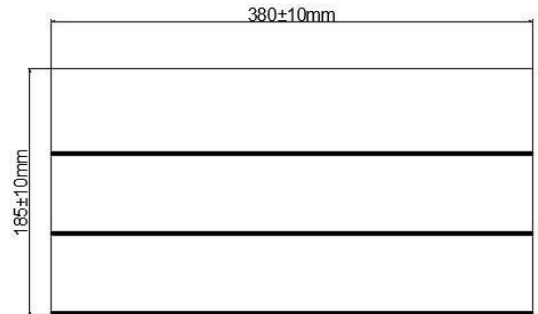
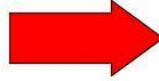
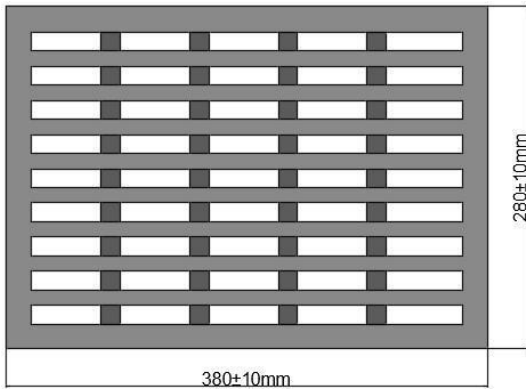

1. EPE size:38*28*6cm
2. Each EPE has 45 cells,The middle 270 cells are not filled

Each box is packed with 3 layers of EPE,The EPE is Separated by cardboard cotton, which can contain 810 products



1. Each layer of pearl cotton can hold 270 pcs of products;
2. Each box can contain 3 layers of pearl

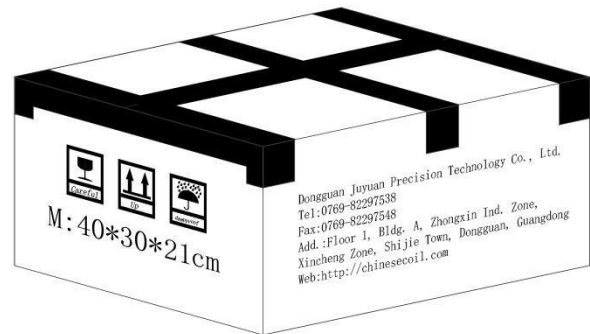

Product	Single layer quantity	Layer/Box	Total/Box	Weigh
A11	270pcs	3layer	810pcs	

Material List

Customer P / N		A25M1		Supplier P / N	
No.	Material Name	Material Specification	Material Code	Manufacturer	
1	self-bonded silk wrapped wire	0.08*105P	01.00139		
2	lead-free tin	High Temperature	05.00058		
3	Glue	resin adhesiveresin	05.00001		
4	High Temperature Tape	8mm	05.00023		
5	Round Hard Magnet	50*1mm	02.00035		
6	Double Side Tape	49*0.08mm	05.00070		
7	EPE	378*270mm	04.00020		
8	Package	380*280*55mm	04.00018		
9	Carton	400*300*190mm	04.00008		
10					
11					
12					
13					
14					

