

SPECIFICATION FOR APPROVAL

CUSTOMER: **SZ105**

CUST P/N:

FINE P/N:

DESC: **FYSZ10512023041501**

DATE: **2023/08/08**

Version: **A.0**

PREPARED BY	CHECKED BY	APPROVED BY	CUSTOMER APPROVE
Huangxiaoyuan	CAI jyu	Ding Baoyuan	

Dongguan FANYA Electronics Co., LTD

Factory address: No.194, Liuwu Technology East Road, Shijie Town, Dongguan City

TEL: 0769-22490287 / 22452492

FAX: 0769-22499451

E-mail: fineelec@163.com

SPECIFICATION

DESC	FYSZ10512023041501	Rev: A.0	CUST:	SZ105
			Fine P/N:	
			CUST P/N:	

一、DIMENSION:(mm)

HF ROHS

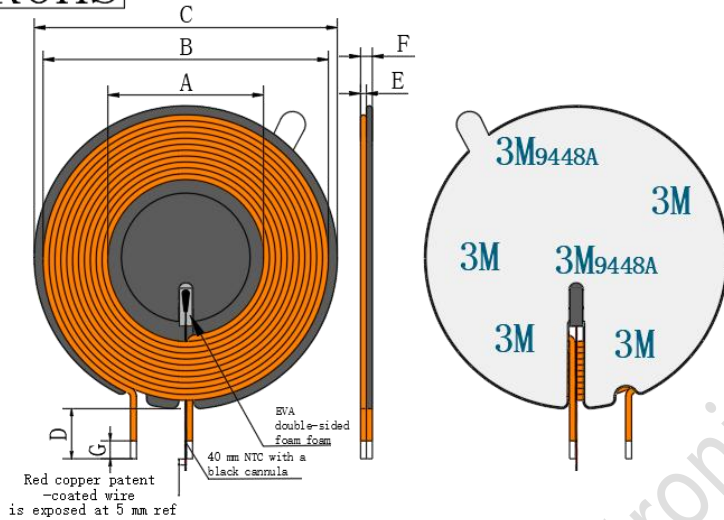

A	21.46±0.5
B	39.3±0.5
C	42.4±0.4
D	5.52±1.5
E	1.03±0.05
F	2.35-2.5 (Excluding the paper thickness)
G	2.5Max(No yellow gum)

注:

- 1.Coil backstick magnetic sheet, Coil backstick magnetic sheet,Middle patch ϕ 18mm * 0.75, slot 5.41*2.03mm, Small magnetic piece one side paste ϕ 15 * 0.08 straight groove with hand tear ordinary back glue;
2. ϕ 41.2 * 0.15 3M9448A with hand tear double-sided back tape.
- 3.EVA double-sided foam size
5. 3*1.8*1.5mm stick in the magnetic chip slot, NTC, model 10K 3380, length 40mm \pm 2, wear black heat-shrink sleeve, red copper patent wrap wire reserved 5 mm again; tin layer 2 \pm 1mm;

二、原理图 SCHEMATIC DIAGRAM:

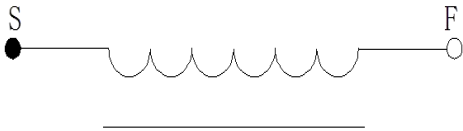

三、Winding Specification:

NO.	TERMINAL	WIRE	Turns	Winding Direction
1	S F	Litz0.08*65p	11Ts	CW

四、ELECTRICAL CHARACTERISTICS:

TEMPERATURE:25±10°C, RELATIVE HUMIDITY:65±20%

NO.	ITEM	TERMINAL	SPECIFICATION	TEST FREQUENCY	TEST EQUIPMENTS
1	IND.	S-F	8.4uH \pm 5%	360KHz/1.0V	TH2810
2	DCR	S-F	70m Ω Max	360KHz/1.0V	TH2810
3	ACR	S-F	150m Ω Max	360KHz/1.0V	TH2810

PREPARED BY/DATE	CHECKED BY/DATE
Huangxiaoyuan 2023/08/08	CAI jyu 2023/08/08

SPECIFICATION

DESC	FYSZ10512023041501	Rev: A.0	CUST:	SZ105
			Fine P/N:	
			CUST P/N:	

五、PACKONG:

5.1 Packing pictures:

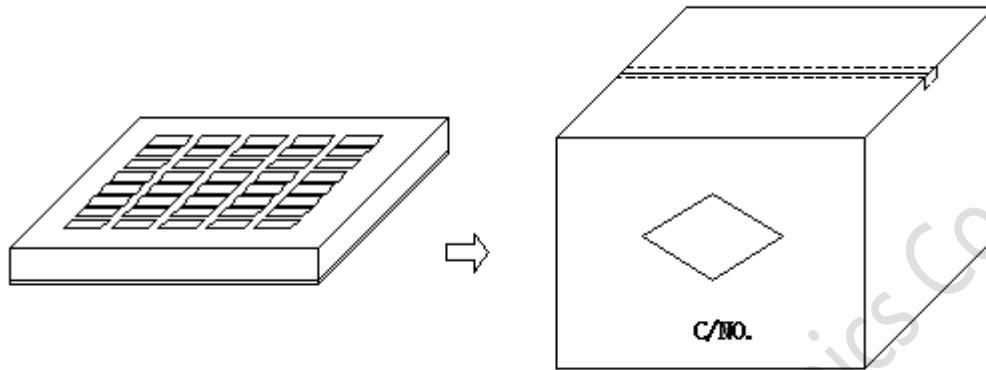

5.2 Packing Quantity:

Item	Quantity	Material
Box	200 Pcs	370*265*55mm
Big Carton	1000 Pcs	420*270*310mm

5.3 The packaging shall be based on the existing packing plate and the actual delivery package shall prevail. If there is any requirement, we can customize it.

六、Material list:

number	Material name	Description	Manufacturer
1	Litz0.08*65p	Litz0.08*65p	
2	No lead tin strip	No lead tin strip	
3	magnetic sheet	Magnetic chip size $\phi 42.4 \times 1.15$ mm, open double straight groove	
4	Small magnetic sheet	Small magnetic sheet	
5	3M9448A back glue	$\phi 41.2 * 0.15$ double groove 3M9448A with hand tear double-sided backing	
6	Ordinary back glue	$\phi 15 * 0.08$ straight groove with hand tear ordinary back glue	
7	EVA double-sided foam foam	Dimension: 5.3*1.8*1.5mm	
8	NTC	Model: 10K 3380, length 40mm, wear black heat-shrink sleeve	

PREPARED BY/DATE	CHECKED BY/DATE
Huangxiaoyuan 2023/08/08	CAI jyu 2023/08/08