

# SPECIFICATION FOR APPROVAL

## 1.MECHANICAL DIMENSION (UNIT:mm)

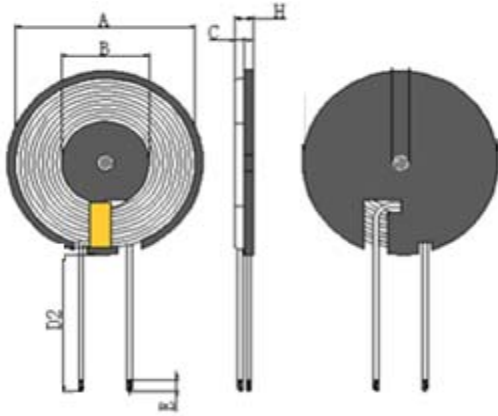

## 2. SCHEMATICS:

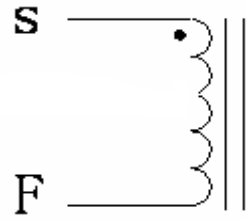

A	B	C	D2	E	H				I
50±1.0	20.5±0.5	0.8±0.1	5±3	4±2	2.8MAX				

## 3.WINDING:

STEP	START-FINISH	WIRE TYPE	TURNS	TAPE	REMARK
N1	S-F	∅0.08*105P 2UEW	10TS (Ref)		

## 4. ELECTRICAL SPECIFICATION:

ITEM	L	DCR		Q值	HI-POT
TEST	coil	S-F			
CON	100KHz, 0.25V	AT 25°C			
SPEC	6.5uH±10%	60mΩ Max			

## 5.BILF OF MATERIAL:

NO.	ITEM	MATERIAL SPECIFICATION	MANUFACTURER	SGS NO.
1	enamelled wire	0.08*105	NANJINGJINNINGCO,LTD	
2	Solder Bar	Solder Bar	QIAODO	
3	magnetic sheet	∅50 Manganese zinc hard magnetic sheet	TAIYI CO.,LTD	
4	glue	Yellow Glue9999	LIANCHENG CO.,LTD	
5	adhesive tape	8mm High temperature adhesive tape	CUDAK CO.,LTD	
6	Adhesive backing	∅25*0.1	CUDAK CO.,LTD	

HRSW ELECTRONICS CO.,LTD		PART NO	
		TITLE	G50+Adhesive backing5mm
DRAWN BY	CHECKED BY	APPROVED BY	

# SPECIFICATION FOR APPROVAL

6. SAMPLE TEST DATA									
6. 1DIMENSION TEST (UNIT:mm)									
TEST ITEM	A	B	C	D2	E	H			
SPEC	50±1.0	20.5±0.5	0.8±0.1	5±3	4±2	2.8MAX			
1	50.1	20.51	0.85	5.3	3.50	2.41			
2	49.98	20.53	0.83	5.2	3.60	2.43			
3	49.06	20.51	0.87	5.4	3.70	2.36			
4	49.68	20.49	0.89	4.9	3.80	2.30			
5	50	20.5	0.78	5.6	4.00	2.31			
6									
7									
8									
9									
10									
MAX	50.10	20.53	0.89	5.60	4.00	2.43			
MIN	49.06	20.49	0.78	4.90	3.50	2.30			
AVERAGE	49.76	20.51	0.84	5.28	3.72	2.36			
6. 2ELECTRICAL TEST									
TEST ITEM	L		DCR	IDC		Q	HI-POT		
	S-F		S-F						
TEST COND	100KHz/0.25v		AT 25°C						
SPEC	6.5uH ±10%		60mΩ(Max)						
1	6.51		46.80						
2	6.53		47.10						
3	6.49		46.90						
4	6.53		46.80						
5	6.51		47.90						
6									
7									
8									
9									
10									
MAX	6.53		47.90						
MIN	6.49		46.80						
AVERAGE	6.51		47.10						
HRSW ELECTRONICS CO., LTD					PART NO				
					TITLE		G50开槽+背胶5mm		
DRAWN BY			CHECKED BY			APPROVED BY			