

**ELECTROMAGNETIC EMISSIONS COMPLIANCE REPORT
INTENTIONAL RADIATOR CERTIFICATION TO
FCC PART 15 SUBPART C REQUIREMENT**

OF

DANALE AI CAMERA

Model No.: IH6S5H0S1

FCC ID: 2AOJSIH6S5H0S1

Trademark: *Danale*

Report No.: E01A22110901F00301

Issue Date: December 13, 2022

Prepared for

Alcidae Inc.

**Room 401, Building 14, Shenzhen Software Park, Keji Mid 2nd Road,
Yuehai Sub-district, Nanshan District, Shenzhen**

Prepared by

Dong Guan Anci Electronic Technology Co., Ltd.

**1-2 Floor, Building A, No.11, Headquarters 2 Road, Songshan, Lake
Hi-tech Industrial Development Zone, Dongguan City, Guangdong Pr.,
China.**

**This report shall not be reproduced, except in full, without the written approval of
Dong Guan Anci Eleaactronic Technology Co., Ltd.**

VERIFICATION OF COMPLIANCE

Applicant:	Alcidae Inc.. Room 401, Building 14, Shenzhen Software Park, Keji Mid 2nd Road, Yuehai Sub-district, Nanshan District, Shenzhen.
Manufacturer:	Alcidae Inc.. Room 401, Building 14, Shenzhen Software Park, Keji Mid 2nd Road, Yuehai Sub-district, Nanshan District, Shenzhen
Product Description:	DANALE AI CAMERA
Trade Mark:	Danale
Model Number:	IH6S5H0S1

We hereby certify that:

The above equipment was tested by Dong Guan Anci Electronic Technology Co., Ltd. The test data, data evaluation, test procedures, and equipment configurations shown in this report were made in accordance with the procedures given in ANSI C63.10-2013 and the energy emitted by the sample EUT tested as described in this report is in compliance with conducted and radiated emission limits of FCC Rules Part 15.247(2022).

Date of Test : December 09, 2022 to December 13, 2022

Prepared by :



Reviewer & Authorized
Signer :

Tiger Xu/ Supervisor

Modified Information

Version	Summary	Revision Date	Report No.
Ver.1.0	Original Report	/	E01A22110901F00301

Table of Contents

1. GENERAL INFORMATION	5
1.1 PRODUCT DESCRIPTION	5
1.2 TEST METHODOLOGY	6
2. SYSTEM TEST CONFIGURATION.....	6
2.1 EUT CONFIGURATION	6
2.2 EUT EXERCISE	6
2.3 TEST PROCEDURE	6
2.4 CONFIGURATION OF TESTED SYSTEM.....	6
3. DESCRIPTION OF TEST MODES	8
4. SUMMARY OF TEST RESULTS.....	14
5. TEST FACILITY.....	15
6. CONDUCTED EMISSIONS TEST	16
6.1 MEASUREMENT PROCEDURE:	16
6.2 TEST SET-UP (BLOCK DIAGRAM OF CONFIGURATION).....	16
6.3 MEASUREMENT EQUIPMENT USED:	16
6.4 CONDUCTED EMISSION LIMIT	16
6.5 MEASUREMENT RESULT:.....	17
7. RADIATED EMISSION TEST	19
7.1 MEASUREMENT PROCEDURE	19
7.2 TEST SET-UP (BLOCK DIAGRAM OF CONFIGURATION).....	20
7.3 MEASUREMENT EQUIPMENT USED	21
7.4 RADIATED EMISSION LIMIT	22
7.5 MEASUREMENT RESULT	24
8. 6DB BANDWIDTH TEST	29
8.1 MEASUREMENT PROCEDURE	29
8.2 TEST SET-UP (BLOCK DIAGRAM OF CONFIGURATION).....	29
8.3 MEASUREMENT EQUIPMENT USED	29
8.4 MEASUREMENT RESULTS.....	30
9. MAXIMUM PEAK OUTPUT POWER TEST	36
9.1 MEASUREMENT PROCEDURE	36
9.2 TEST SET-UP (BLOCK DIAGRAM OF CONFIGURATION).....	36
9.3 MEASUREMENT EQUIPMENT USED	36
9.4 PEAK POWER OUTPUT LIMIT	37
9.5 MEASUREMENT RESULTS.....	37
10. BAND EDGE TEST	38
10.1 MEASUREMENT PROCEDURE	38
10.2 TEST SET-UP (BLOCK DIAGRAM OF CONFIGURATION).....	39
10.3 MEASUREMENT EQUIPMENT USED	39
10.4 MEASUREMENT RESULTS.....	40
11. POWER DENSITY	47
11.1 TEST EQUIPMENT	47
11.2 MEASURING INSTRUMENTS AND SETTING.....	47
11.3 TEST PROCEDURES.....	47
11.4 BLOCK DIAGRAM OF TEST SETUP	48
11.5 LIMIT.....	48
11.6 TEST RESULT.....	48
12. ANTENNA PORT EMISSION	54

- 12.1 TEST EQUIPMENT 54
- 12.2 MEASURING INSTRUMENTS AND SETTING..... 54
- 12.3 TEST PROCEDURES..... 54
- 12.4 BLOCK DIAGRAM OF TEST SETUP..... 54
- 12.5 TEST RESULT 55
- 13. ANTENNA APPLICATION 65**
 - 13.1 ANTENNA REQUIREMENT..... 65
 - 13.2 RESULT 65
- 14. PHOTOS OF EUT 66**

1. General Information

1.1 Product Description

Characteristics	Description
Product Name	DANALE AI CAMERA
Model number	IH6S5H0S1
Power Supply	DC 5V, 1.5A
Test Power Supply	DC 5V from adapter
Adapter Information	Model: PS10UA050K1500UU Input: AC 100-240V, 50/60Hz, 0.35A Max Output: DC 5V, 1.5A 7.5W Model: ES568F-US-0500150 Input: AC 100-240V, 50/60Hz, 0.5A Max Output: DC 5V, 1.5A
Modulation	802.11b: DSSS(DBPSK/DQPSK/CCK) 802.11g/n: OFDM(BPSK/QPSK/16QAM/64QAM)
Operating Frequency Range	2412-2462MHz for 802.11b/g; 2412-2462MHz for 802.11n(HT20);
Number of Channels	11 channels for 802.11b/g; 11 channels for 802.11n(HT20);
Transmit Power Max	802.11b: 15.12dBm 802.11g: 15.39dBm 802.11n(HT20): 14.97dBm
Antenna Type	Internal antenna
Antenna Gain	2.82dBi
Sample receipt date	December 09, 2022

Note: for more details, please refer to the User's manual of the EUT.

1.2 Test Methodology

All the test program has follow FCC new test procedure KDB 558074 D01 15.247 Meas Guidance v05r02 and in accordance with the procedures given in ANSI C63.10-2013.

2. System Test Configuration

2.1 EUT Configuration

The EUT configuration for testing is installed on RF field strength measurement to meet the Commissions requirement and operating in a manner which intends to maximize its emission characteristics in a continuous normal application.

2.2 EUT Exercise

The Transmitter was operated in the normal operating mode. The TX frequency was fixed which was for the purpose of the measurements.

2.3 Test Procedure

2.3.1 Conducted Emissions

The EUT is a placed on as turn table which is 0.8 m above ground plane. According to the requirements in Section 13.1.4.1 of ANSI C63.10-2013 Conducted emissions from the EUT measured in the frequency range between 0.15 MHz and 30 MHz using CISPR Quasi-Peak and average detector mode.

2.3.2 Radiated Emissions

The EUT is a placed on as turn table which is 0.8 m above ground plane. The turn table shall rotate 360 degrees to determine the position of maximum emission level. EUT is set 3m away from the receiving antenna which varied from 1m to 4m to find out the highest emission. And also, each emission was to be maximized by changing the polarization of receiving antenna both horizontal and vertical. In order to find out the max. Emission, the relative positions of this hand-held transmitter (EUT) was rotated through three orthogonal axes according to the requirements in Section 13.1.4.1 of ANSI C63.10-2013.

2.4 Configuration of Tested System

Fig. 2-1 Configuration of Tested System

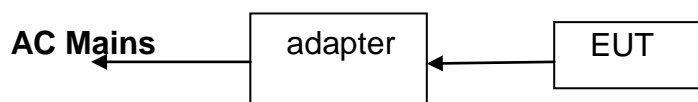

Table 2-1 Equipment Used in Tested System

Item	Equipment	Trademark	Model No.	FCC ID	Note
1.	DANALE AI CAMERA	Danale	IH6S5H0S1	2AOJSIH6S5H0S1	<i>EUT</i>
2.	Adapter	N/A	ES568F-US-0500150 PS1OUA050K1500UU	N/A	<i>Support EUT</i>

Note:

- (1) Unless otherwise denoted as EUT in 『Remark』 column, device(s) used in tested system is a support equipment.

3. Description of Test Modes

The EUT has been tested under its typical operating condition and Only the worst case data were reported. The EUT configuration for testing is installed on RF field strength measurement to meet the Commissions requirement and operating in a manner which intends to maximize its emission characteristics in a continuous normal application.

The Transmitter was operated in the normal operating mode. The TX frequency was fixed which was for the purpose of the measurements.

Test of channel included the lowest and middle and highest frequency to perform the test, then record on this report.

Those data rates (802.11b: 1 Mbps; 802.11g: 6 Mbps; 802.11n (HT20): MCS0) were used for all test. Pre-defined engineering program for regulatory testing used to control the EUT for staying in continuous transmitting mode is programmed. EUT is connected by com port, and transmit the control instruction via test software(SecureCRT V7.4.2.exe).

Frequency and Channel list for 802.11 b/g/n (HT20):

Channel	Frequency (MHz)	Channel	Frequency (MHz)	Channel	Frequency (MHz)
1	2412	5	2432	9	2452
2	2417	6	2437	10	2457
3	2422	7	2442	11	2462
4	2427	8	2447		

Test Frequency and Channel for 802.11 b/g/n (HT20):

Lowest Frequency		Middle Frequency		Highest Frequency	
Channel	Frequency (MHz)	Channel	Frequency (MHz)	Channel	Frequency (MHz)
1	2412	6	2437	11	2462

Operated Mode for Worst Duty cycle:

Duty Cycle:

Condition	Mode	Frequency (MHz)	Antenna	Duty Cycle (%)	Correction Factor (dB)	1/T (kHz)
NVNT	b	2412	Ant1	99.86	0	0
NVNT	b	2437	Ant1	99.85	0	0
NVNT	b	2462	Ant1	99.86	0	0
NVNT	g	2412	Ant1	98.7	0	0.37
NVNT	g	2437	Ant1	98.7	0	0.37
NVNT	g	2462	Ant1	98.7	0	0.37
NVNT	n20	2412	Ant1	98.6	0	0.39
NVNT	n20	2437	Ant1	98.6	0	0.39
NVNT	n20	2462	Ant1	98.6	0	0.39

All the modulation modes were tested , the data is recorded in the following pages:

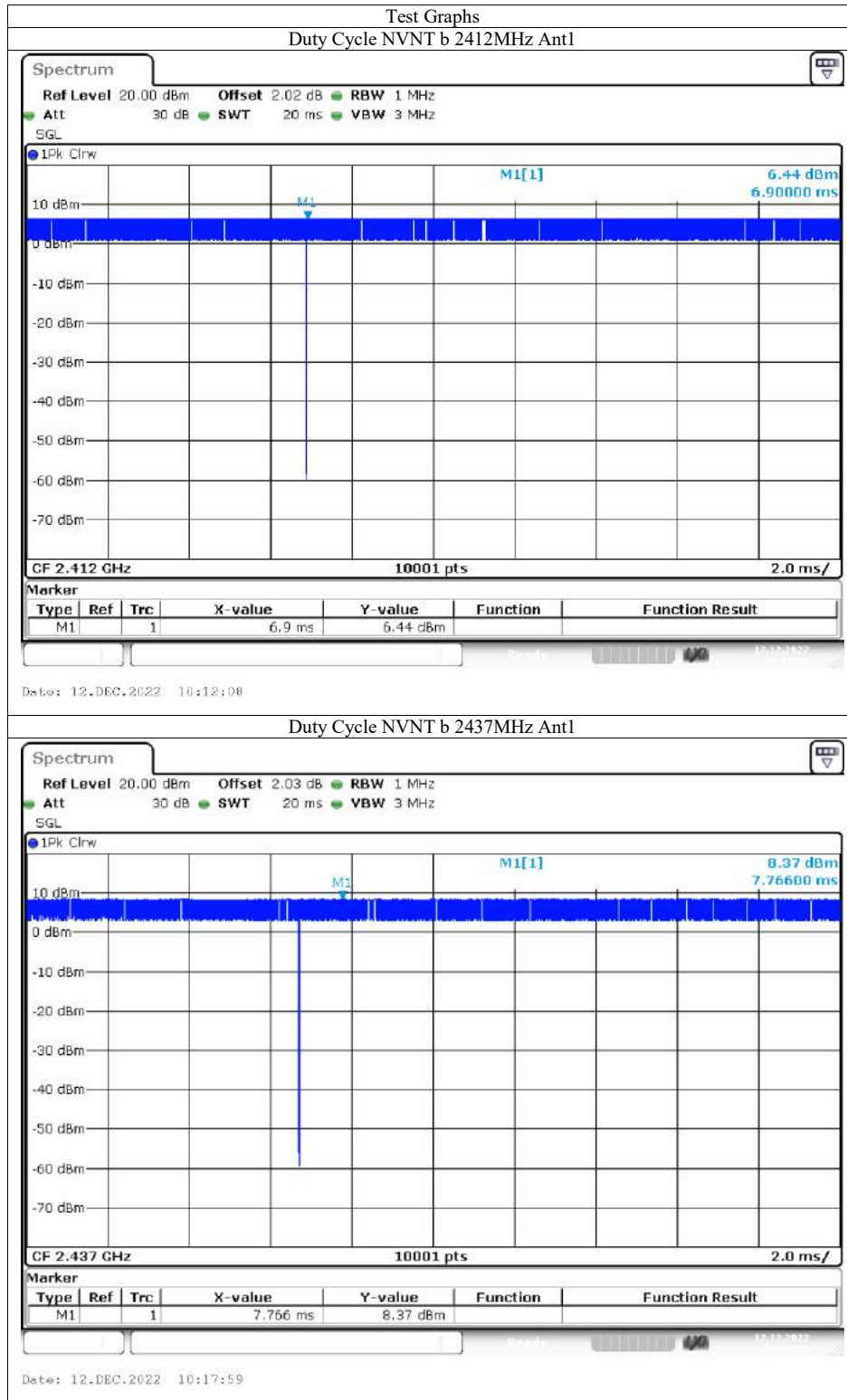

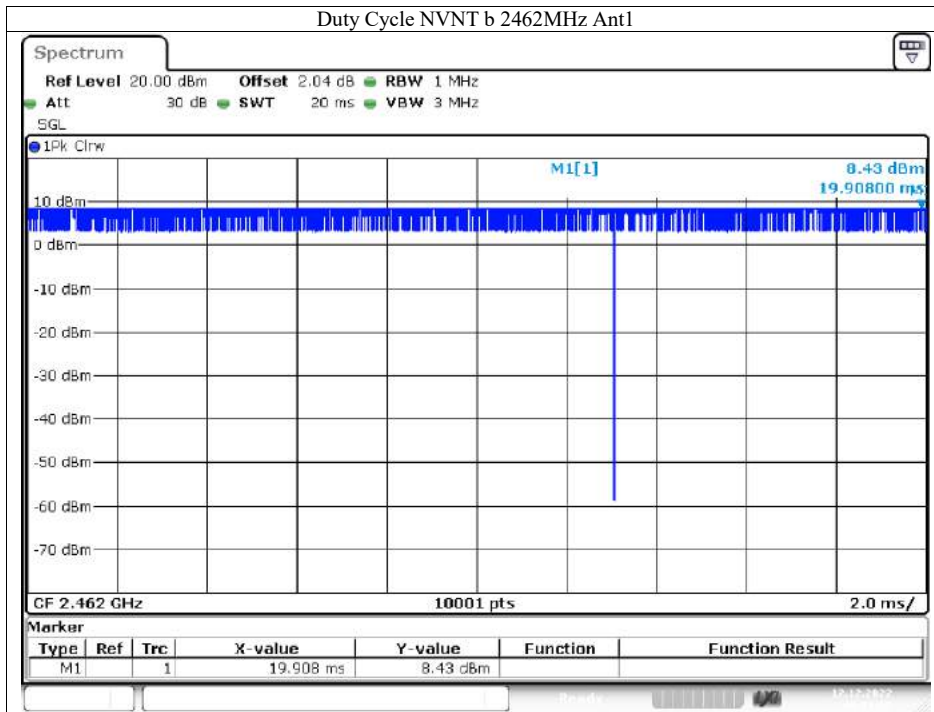

Date: 12-DEC-2022 10:21:27

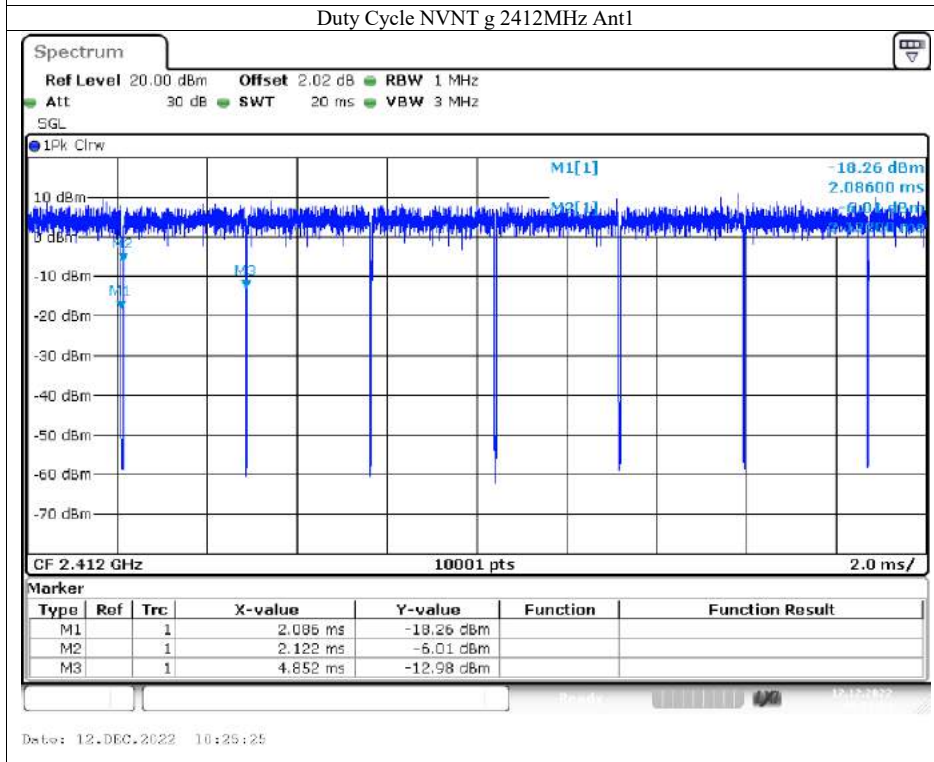

Date: 12-DEC-2022 10:25:25

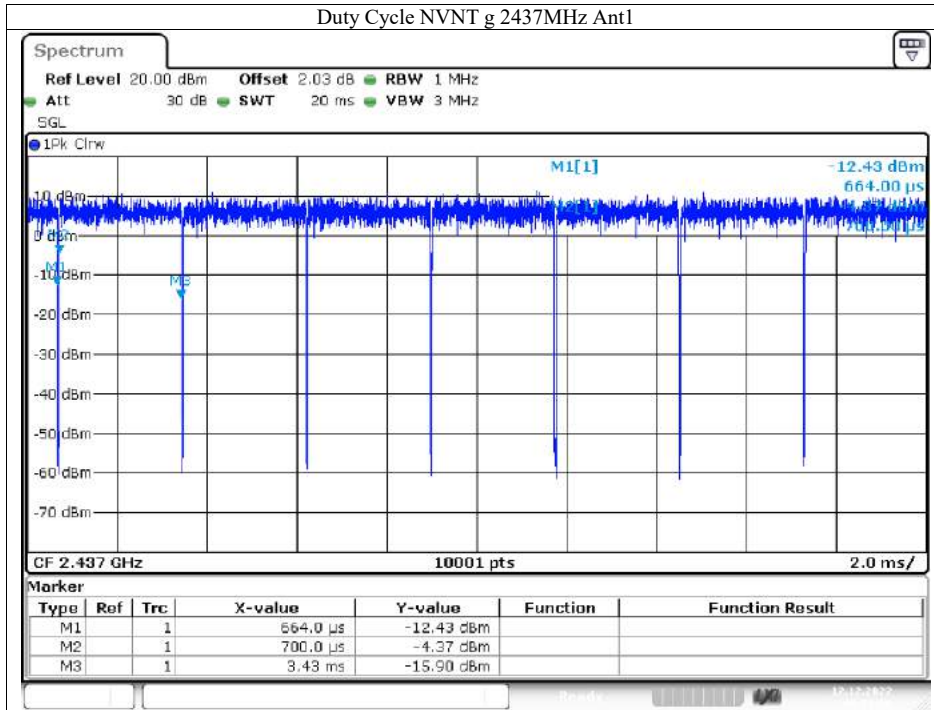

Date: 12.DEC.2022 10:29:37

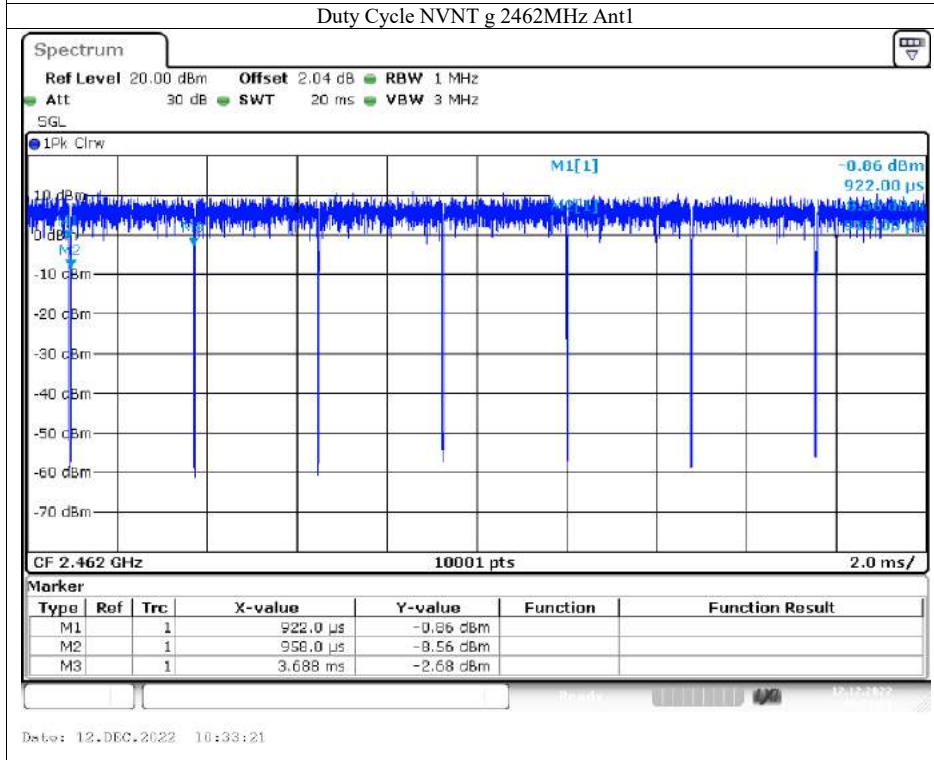

Date: 12.DEC.2022 10:33:21

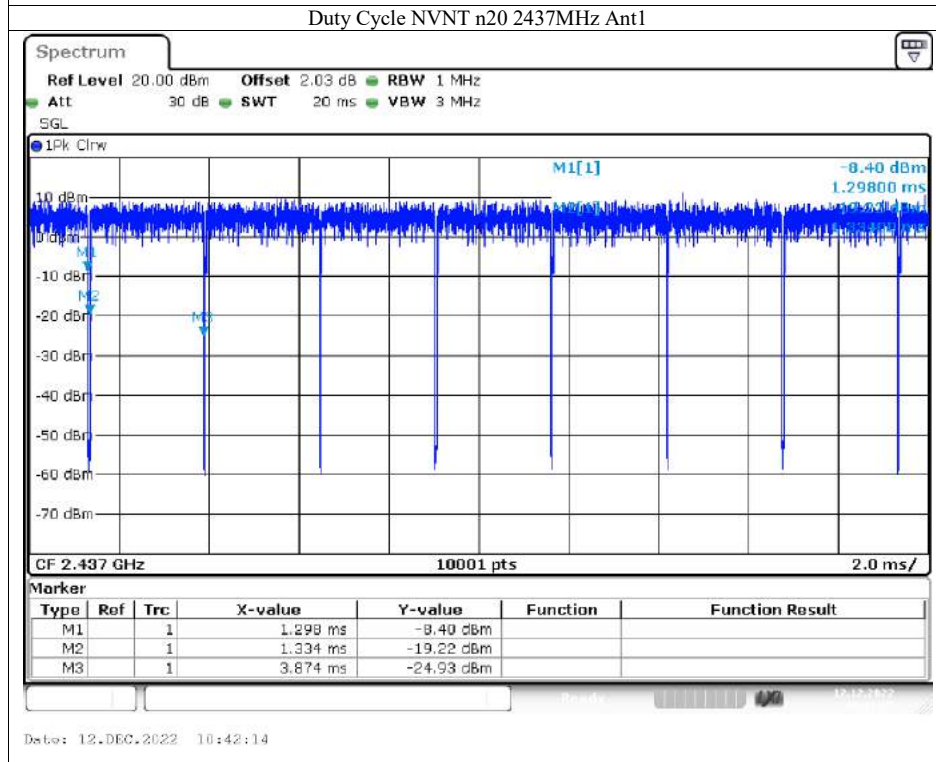
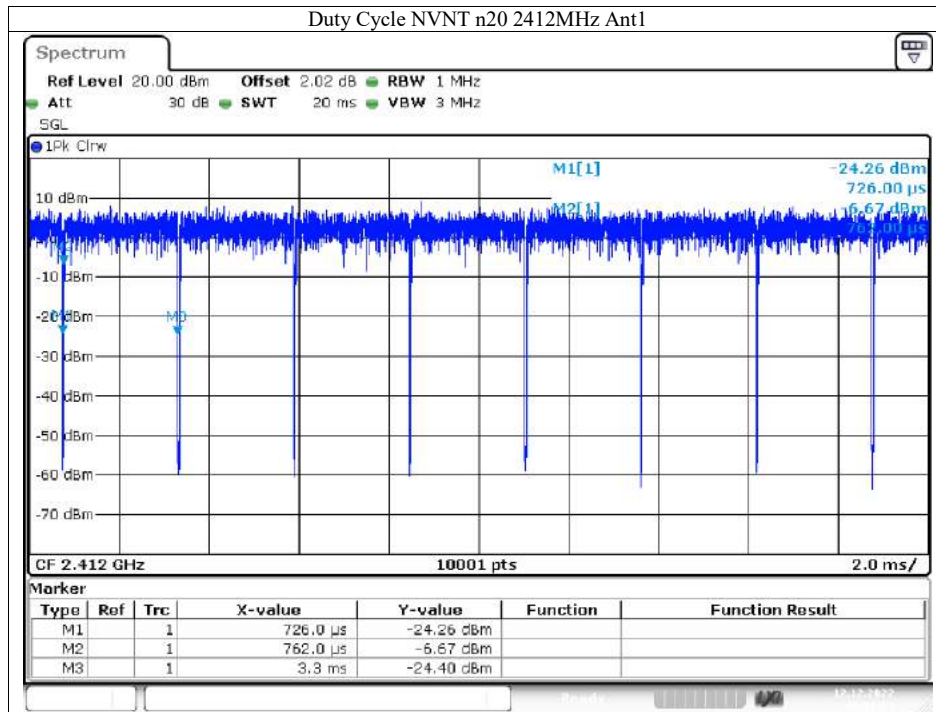

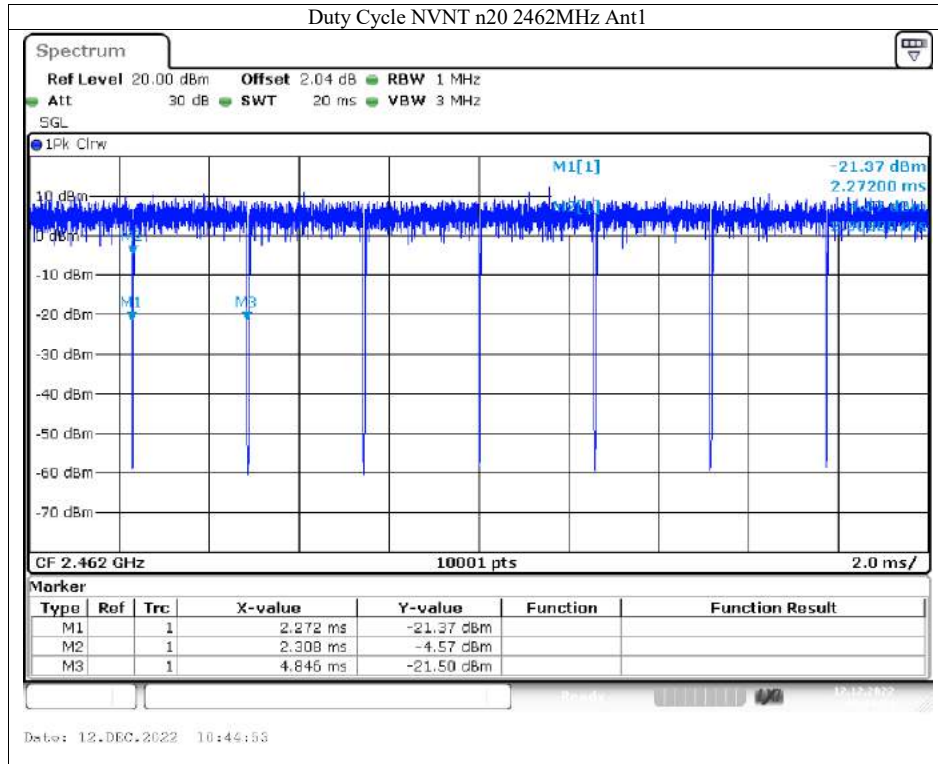

4. Summary of Test Results

FCC Rules	Description Of Test	Result
§15.247(a)(2)	6dB bandwidth	Pass
§15.247(b)(3)	Max Peak output Power test	Pass
§15.247(e)	Power density	Pass
§15.247(d)	Band edge test	Pass
§15.207	AC Power Conducted Emission	Pass
§15.247(d), §15.209	Radiated Emission	Pass
§15.247(d)	Antenna Port Emission	Pass
§15.247(b)&§15.203	Antenna Application	Pass
N/A (Not Applicable).		

5. Test Facility

Site Description

Name of Firm : Dong Guan Anci Electronic Technology Co., Ltd.
Site Location : 1-2 Floor, Building A, No.11, Headquarters 2 Road,
Songshan, Lake Hi-tech Industrial Development
Zone, Dongguan City, Guangdong Pr., China.

6. Conducted Emissions Test

6.1 Measurement Procedure:

1. The EUT was placed on a table, which is 0.8m above ground plane.
2. Maximum procedure was performed on the six highest emissions to ensure EUT compliance.
3. Repeat above procedures until all frequency measured was complete.

6.2 Test SET-UP (Block Diagram of Configuration)

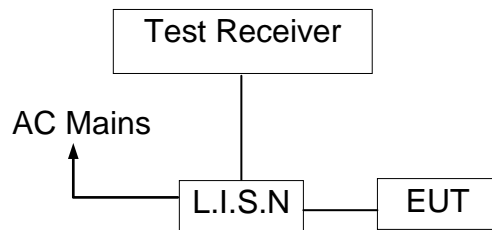

6.3 Measurement Equipment Used:

C	Instr.Code	Kind of Equipment	Manufacturer	Type No.	Serial No.	Calibrated until
1	AN-E010	L.I.S.N	SCHWARZBECK	NSLK 8127	8127-669	2023-05-12
2	AN-E078	TRANSIENT LIMITER	CYBERTEK	EM5010A	E1950100113	2023-05-12
3	AN-E022	RF Cable	N/A	ZT06S-BNCJ-NJ-7.5M	19044020	2023-05-12
4	AN-E020	EMI Test Receiver	ROHDE&SCHWARZ	ESCI	101358	2023-05-12
5	AN-E058	1# Shielded Room	chengyu	8m*4m*3.3m	N/A	2024-11-12
6	AN-E046	Test Software	Farad	EZ-EMC (Ver.ANCI-3A1)	N/A	N/A

6.4 Conducted Emission Limit

(7) Conducted Emission Frequency(MHz)

0.15-0.5

0.5-5.0

5.0-30.0

Quasi-peak

66-56

56

60

Average

56-46

46

50

Note:

1. The lower limit shall apply at the transition frequencies
2. The limit decreases in line with the logarithm of the frequency in the range of 0.15 to 0.50MHz.

6.5 Measurement Result:

All the modulation modes were tested the data of the worst mode (802.11 n20 TX2437) are recorded in the following pages and the others modulation methods do not exceed the limits. Please refer to following pages.

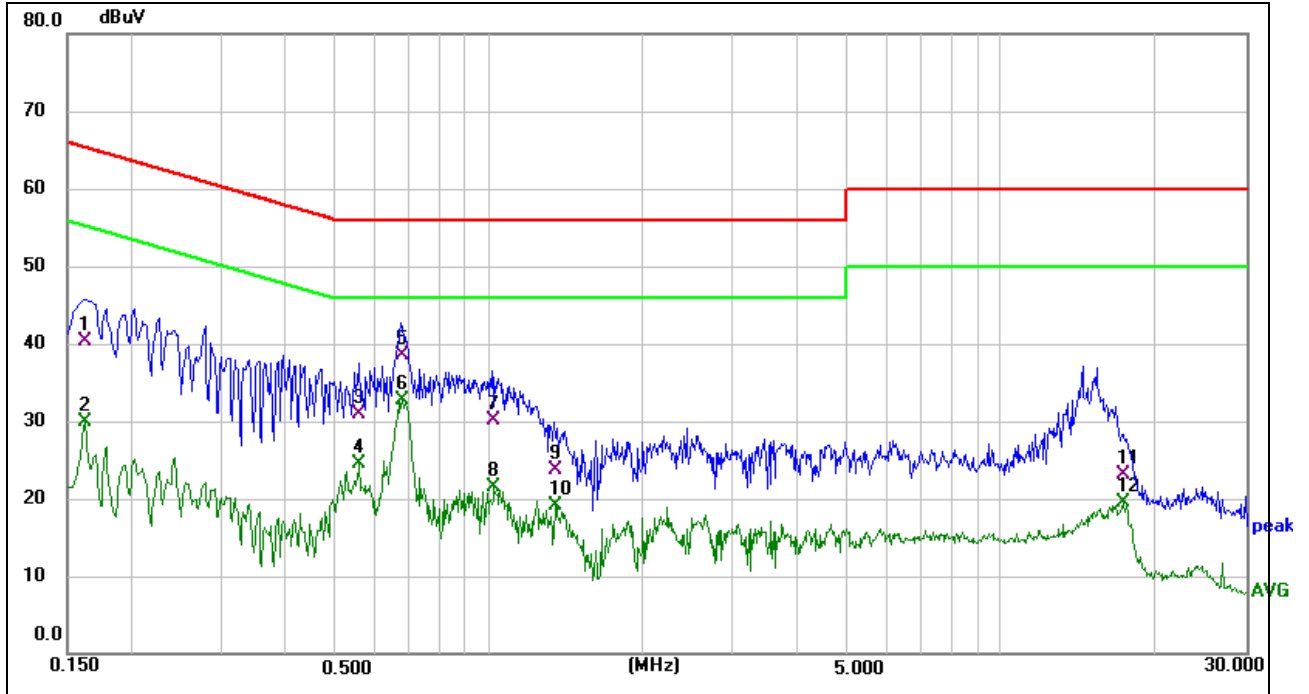

Site:	ANCI 843	Phase:	N	Temperature(C):	23.5(C)
Limit:	FCC Part 15 Class B Conduction(QP)			Humidity(%):	52.6%
EUT:	DANALE AI CAMERA	Test Time:	2022-12-13 8:50:28		
M/N.:	IH6S5H0S1	Power Rating:	AC 120V/60Hz		
Mode:	TX 2437	Test Engineer:	Jayce		
Note:	ES568F-US-0500150				

No.	Frequency (MHz)	Reading Level(dBuV)	Factor (dB)	Measurement(dBuV)	Limit (dBuV)	Over (dB)	Detector	Comment
1	0.1620	30.54	9.82	40.36	65.36	-25.00	QP	
2	0.1620	19.99	9.82	29.81	55.36	-25.55	AVG	
3	0.5580	21.31	9.68	30.99	56.00	-25.01	QP	
4	0.5580	14.74	9.68	24.42	46.00	-21.58	AVG	
5	0.6780	28.92	9.61	38.53	56.00	-17.47	QP	
6 *	0.6780	23.12	9.61	32.73	46.00	-13.27	AVG	
7	1.0220	20.18	9.99	30.17	56.00	-25.83	QP	
8	1.0220	11.60	9.99	21.59	46.00	-24.41	AVG	
9	1.3500	13.63	9.98	23.61	56.00	-32.39	QP	
10	1.3500	9.15	9.98	19.13	46.00	-26.87	AVG	
11	17.3340	12.97	10.23	23.20	60.00	-36.80	QP	
12	17.3340	9.31	10.23	19.54	50.00	-30.46	AVG	

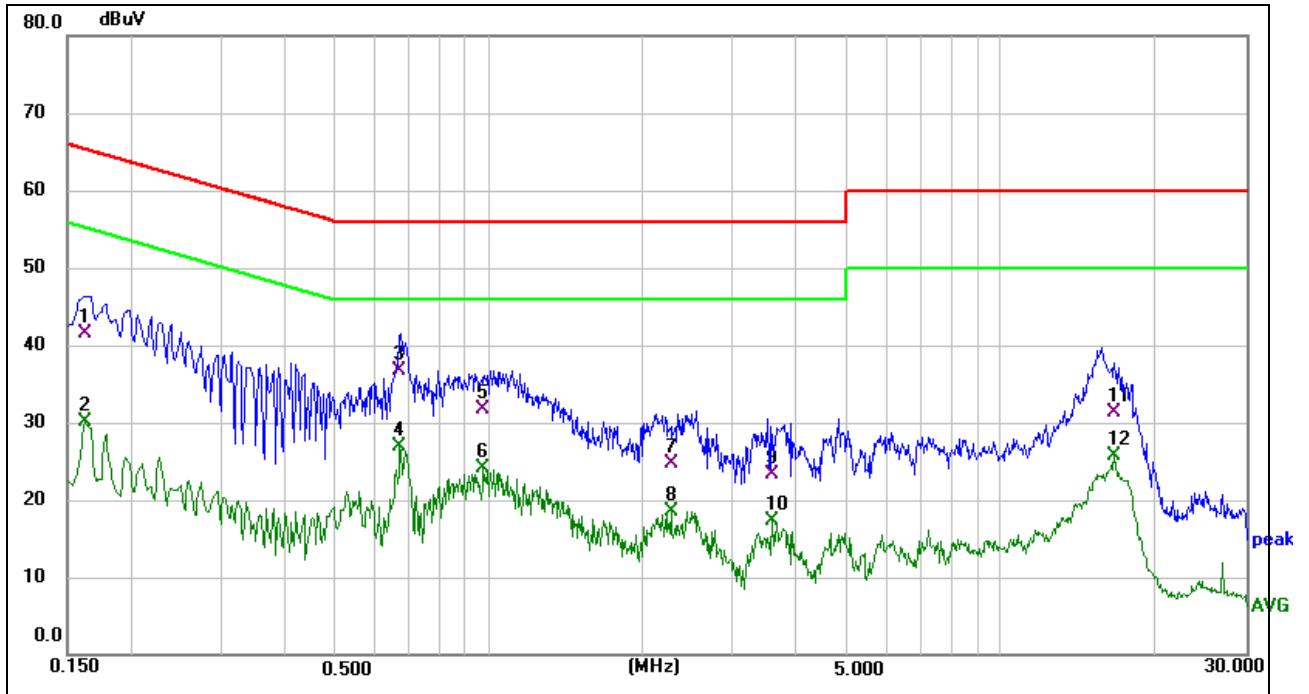

Site:	ANCI 843	Phase:	L1	Temperature(C):	23.5(C)
Limit:	FCC Part 15 Class B Conduction(QP)	Test Time:	2022-12-13 8:46:57	Humidity(%):	52.6%
EUT:	DANALE AI CAMERA	Power Rating:	AC 120V/60Hz	Test Engineer:	Jayce
M/N.:	IH6S5H0S1	Note:	ES568F-US-0500150		
Mode:	TX 2437				

No.	Frequency (MHz)	Reading Level(dBuV)	Factor (dB)	Measurement(dBuV)	Limit (dBuV)	Over (dB)	Detector	Comment
1	0.1620	31.59	9.87	41.46	65.36	-23.90	QP	
2	0.1620	20.15	9.87	30.02	55.36	-25.34	AVG	
3	0.6700	27.27	9.48	36.75	56.00	-19.25	QP	
4 *	0.6700	17.44	9.48	26.92	46.00	-19.08	AVG	
5	0.9740	21.71	10.02	31.73	56.00	-24.27	QP	
6	0.9740	14.01	10.02	24.03	46.00	-21.97	AVG	
7	2.2700	14.62	10.05	24.67	56.00	-31.33	QP	
8	2.2700	8.55	10.05	18.60	46.00	-27.40	AVG	
9	3.5700	13.28	10.03	23.31	56.00	-32.69	QP	
10	3.5700	7.25	10.03	17.28	46.00	-28.72	AVG	
11	16.6220	21.13	10.26	31.39	60.00	-28.61	QP	
12	16.6220	15.35	10.26	25.61	50.00	-24.39	AVG	

7. Radiated Emission Test

7.1 Measurement Procedure

1. Below 1000MHz, The EUT was placed on a turn table which is 0.8m above ground plane, And above 1000MHz, The EUT was placed on a styrofoam table which is 1.5m above ground plane.
2. Maximum procedure was performed on the six highest emissions to ensure EUT compliance.
3. And also, each emission was to be maximized by changing the polarization of receiving antenna both horizontal and vertical.
4. Repeat above procedures until all frequency measured was complete.

When spectrum scanned from 30MHz to 1GHz setting resolution bandwidth 120KHz and video bandwidth 300KHz:

EMI Test Receiver	Setting
Attenuation	Auto
RB	120KHz
VB	300KHz
Detector	QP
Trace	Max hold

When spectrum scanned above 1GHz setting resolution bandwidth 1MHz, video bandwidth 3MHz:

EMI Test Receiver	Setting
Attenuation	Auto
RB	1MHz
VB	3MHz
Detector	Peak
Trace	Max hold

When spectrum scanned above 1GHz setting resolution bandwidth 1MHz, video bandwidth 10Hz:

EMI Test Receiver	Setting
Attenuation	Auto
RB	1MHz
VB	10Hz
Detector	Peak
Trace	Max hold

7.2 Test SET-UP (Block Diagram of Configuration)

(A) Radiated Emission Test Set-Up, Frequency Below 30MHz

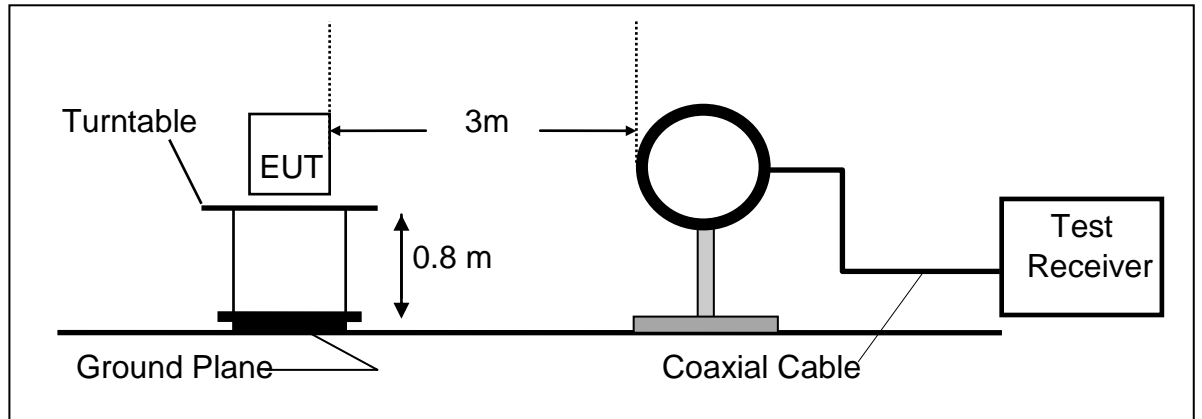

(B) Radiated Emission Test Set-Up, Frequency Below 1000MHz

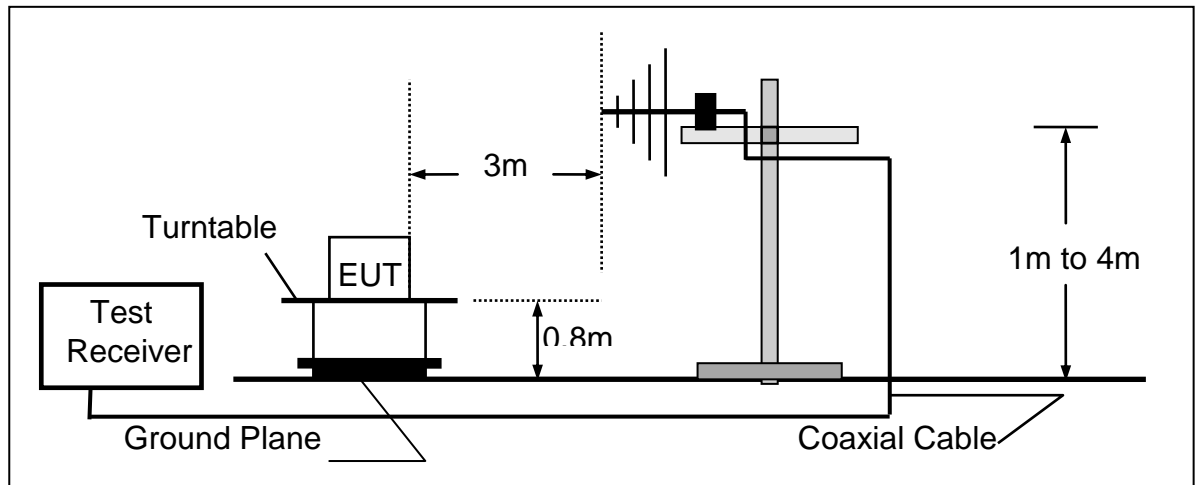

(C) Radiated Emission Test Set-Up, Frequency above 1000MHz

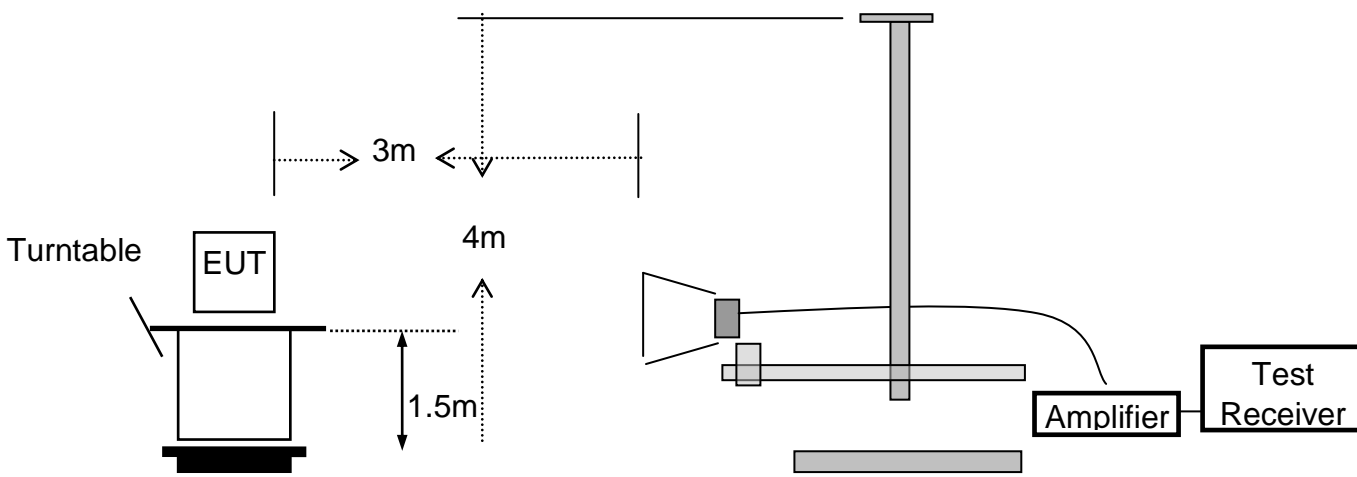

7.3 Measurement Equipment Used

3m Radiated Emission Measurement 30MHz-1GHz

Item	Instr. Code	Kind of Equipment	Manufacturer	Type No.	Serial No.	Calibrated until
1	AN-E060	EMI Test Receiver	Rohde & Schwarz	ESCI	100302	2023-05-12
2	AN-E061	Pre-Amplifier	Anritsu	MH648A	M57886	2023-05-12
3	AN-E076	Bilog Antenna	Schwarzbeck	VULB9163	VULB9163-1290	2022-11-11
4	AN-E063	RF Cable	N/A	ZT06S-NJ-NJ-11M	19060398	2023-05-12
5	AN-E064	RF Cable	N/A	ZT06S-NJ-NJ-0.5M	19060400	2023-05-12
6	AN-E065	RF Cable	N/A	ZT06S-NJ-NJ-2.5M	19060404	2023-05-12
7	AN-E056	3m Semi-anechoic Chamber	chengyu	9m*6m*6m	N/A	2024-11-12
8	AN-E069	Test Software	Farad	EZ-EMC Ver:ANCI-2A1	N/A	N/A

3m Radiated Emission Measurement 1GHz-18GHz

C	Instr.Code	Kind of Equipment	Manufacturer	Type No.	Serial No.	Calibrated until
1	AN-E037	Spectrum Analyzer	Rohde & Schwarz	FSV40	102257	2023-10-07
2	AN-E015	Low noise Amplifiers	A-INFO	LA1018N4009	J1013130524001	2023-05-12
3	AN-E014	Horn antenna	A-INFO	LB-10180-SF	J2031090612123	2023-05-14
4	AN-E065	RF Cable	N/A	ZT26-NJ-NJ-11M	19060401	2023-05-12
5	AN-E067	RF Cable	N/A	ZT26-NJ-NJ-2.5M	19060402	2023-05-12
6	AN-E068	RF Cable	N/A	ZT26-NJ-NJ-0.5M	19060403	2023-05-12
7	AN-E056	3m Semi-anechoic Chamber	chengyu	9m*6m*6m	N/A	2024-11-12
8	AN-E069	Test Software	Farad	EZ-EMC (Ver.FA-03A2 RE)	N/A	N/A

C "N/A" denotes No Model No. / Serial No. and No Calibration specified.

7.4 Radiated Emission Limit

The emissions from an intentional radiator shall not exceed the field strength levels specified in the following table 15.209(a):

Frequencies (MHz)	Field Strength (micovolts/meter)	Measurement Distance (meters)
0.009~0.490	2400/F(KHz)	300
0.490~1.705	24000/F(KHz)	30
1.705~30.0	30	30
30~88	100	3
88~216	150	3
216~960	200	3
Above 960	500	3

15.205 Restricted bands of operation

MHz	MHz	MHz	GHz
0.090 - 0.110	16.42 - 16.423	399.9 - 410	4.5 - 5.15
¹ 0.495 - 0.505	16.69475 - 16.69525	608 - 614	5.35 - 5.46
2.1735 - 2.1905	16.80425 - 16.80475	960 - 1240	7.25 - 7.75
4.125 - 4.128	25.5 - 25.67	1300 - 1427	8.025 - 8.5
4.17725 - 4.17775	37.5 - 38.25	1435 - 1626.5	9.0 - 9.2
4.20725 - 4.20775	73 - 74.6	1645.5 - 1646.5	9.3 - 9.5
6.215 - 6.218	74.8 - 75.2	1660 - 1710	10.6 - 12.7
6.26775 - 6.26825	108 - 121.94	1718.8 - 1722.2	13.25 - 13.4
6.31175 - 6.31225	123 - 138	2200 - 2300	14.47 - 14.5
8.291 - 8.294	149.9 - 150.05	2310 - 2390	15.35 - 16.2
8.362 - 8.366	156.52475 - 156.52525	2483.5 - 2500	17.7 - 21.4
8.37625 - 8.38675	156.7 - 156.9	2690 - 2900	22.01 - 23.12
8.41425 - 8.41475	162.0125 - 167.17	3260 - 3267	23.6 - 24.0
12.29 - 12.293	167.72 - 173.2	3332 - 3339	31.2 - 31.8
12.51975 - 12.52025	240 - 285	3345.8 - 3358	36.43 - 36.5
12.57675 - 12.57725	322 - 335.4	3600 - 4400	(²)

Remark 1. Emission level in dBuV/m=20 log (uV/m)

- :
2. Measurement was performed at an antenna to the closed point of EUT distance of meters.
 3. Only spurious frequency is permitted to locate within the Restricted Bands specified in provision of ξ 15.205, and the emissions located in restricted bands also comply with 15.209 limit.

7.5 Measurement Result

Below 30MHz:

All the modulation modes were tested the data of the test mode are recorded in the following pages.

Operation Mode:	TX Mode	Test Date :	2022-12-12
Frequency Range:	9KHz~30MHz	Temperature :	26°C
Test Result:	PASS	Humidity :	60 %
Measured Distance:	3m	Test By:	Sunshine

Freq. (MHz)	Ant.Pol. H/V	Emission Level (dBuV/m)	Limit 3m (dBuV/m)	Over (dB)
--	--	--	--	--

Note: the amplitude of spurious emission that is attenuated by more than 20dB below the permissible limit has no need to be reported.

Distance extrapolation factor = $40 \log(\text{Specific distance} / \text{test distance})$ (dB);

Limit line = Specific limits (dBuV) + distance extrapolation factor.

Below 1000MHz:

All the modulation modes were tested the data of the worst mode (TX 802.11n20 2437MHz) are recorded in the following pages and the others modulation methods do not exceed the limits.

Please refer to the following test plots:



Site:	LAB	Antenna::	Vertical	Temperature(C):	24.5(C)
Limit:	FCC Part 15 Class B 3m Radiation(QP)			Humidity(%):	53.2%
EUT:	DANALE AI CAMERA	Test Time:	2022/12/12 18:00:05		
M/N.:	IH6S5H0S1	Power Rating:	AC 120V/60Hz		
Mode:	TX 2437	Test Engineer:	Sunshine		
Note:	PS10UA050K1500UU				

No.	Frequency (MHz)	Reading (dBuV)	Factor (dB/m)	Level (dBuV/m)	Limit (dBuV/m)	Margin (dB)	Det.
1	66.2662	39.88	-9.51	30.37	40.00	-9.63	QP
2	135.0319	35.35	-11.71	23.64	43.50	-19.86	QP
3	207.1226	37.25	-11.28	25.97	43.50	-17.53	QP
4	408.9460	35.91	-2.77	33.14	46.00	-12.86	QP
5	595.1329	33.18	0.89	34.07	46.00	-11.93	QP
6 *	916.0687	32.46	5.84	38.30	46.00	-7.70	QP

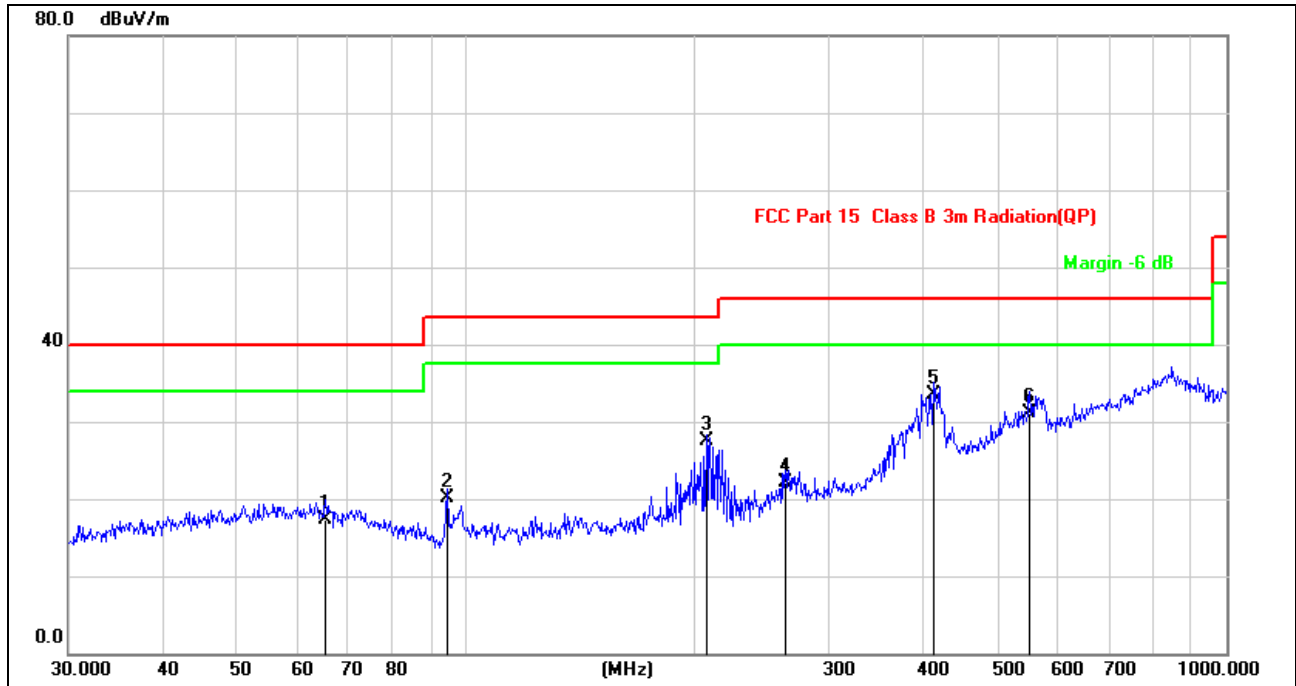

Site: LAB	Antenna:: Horizontal	Temperature(C): 24.5(C)
Limit: FCC Part 15 Class B 3m Radiation(QP)	Test Time:	Humidity(%): 53.2%
EUT: DANALE AI CAMERA	Power Rating:	2022/12/12 18:01:48
M/N.: IH6S5H0S1	Test Engineer:	AC 120V/60Hz
Mode: TX 2437		Sunshine
Note: PS10UA050K1500UU		

No.	Frequency (MHz)	Reading (dBuV)	Factor (dB/m)	Level (dBuV/m)	Limit (dBuV/m)	Margin (dB)	Det.
1	65.3432	26.72	-9.41	17.31	40.00	-22.69	QP
2	94.4284	32.53	-12.39	20.14	43.50	-23.36	QP
3	207.1226	38.86	-11.28	27.58	43.50	-15.92	QP
4	262.8955	30.84	-8.79	22.05	46.00	-23.95	QP
5 *	411.8240	36.30	-2.72	33.58	46.00	-12.42	QP
6	550.9480	30.97	0.04	31.01	46.00	-14.99	QP

Note: 1. Result Level = Read Level+ Antenna Factor+ Cable Loss- Amp. Factor

Above 1GHz:

All the modulation modes were tested the data of the worst mode (TX 802.11 n20) are recorded in the following pages and the others modulation methods do not exceed the limits. The frequency range from 1GHz to 25GHz is investigated.

Operation Mode: 802.11 n20 Lowest Test Date : 2022-12-12
 Test Voltage: AC 120V/60Hz Test by: Sunshine

Freq. (MHz)	Ant. Pol. H/V	Emission Level(dBuV/m)		Limit 3m(dBuV/m)		Over(dB)	
		PK	AV	PK	AV	PK	AV
4824	V	65.68	45.57	74	54	-8.32	-8.43
7236	V	60.01	41.25	74	54	-13.99	-12.75
9648	V	58.87	40.14	74	54	-15.13	-13.86
12060	V	55.05	41.01	74	54	-18.95	-12.99
14472	V	55.15	40.02	74	54	-18.85	-13.98
16884	V	55.31	39.32	74	54	-18.69	-14.68
4824	H	65.81	45.21	74	54	-8.19	-8.79
7236	H	60.35	41.05	74	54	-13.65	-12.95
9648	H	58.05	40.56	74	54	-15.95	-13.44
12060	H	57.35	38.07	74	54	-16.65	-15.93
14472	H	55.02	36.41	74	54	-18.98	-17.59
16884	H	56.28	38.24	74	54	-17.72	-15.76

Operation Mode: 802.11 n20 Middle Test Date : 2022-12-12
 Test Voltage: AC 120V/60Hz Test by: Sunshine

Freq. (MHz)	Ant. Pol. H/V	Emission Level(dBuV/m)		Limit 3m(dBuV/m)		Over(dB)	
		PK	AV	PK	AV	PK	AV
4874	V	64.28	44.31	74	54	-9.72	-9.69
7311	V	60.28	42.08	74	54	-13.72	-11.92
9688	V	59.38	40.21	74	54	-14.62	-13.79
12185	V	58.02	40.01	74	54	-15.98	-13.99
14622	V	58.01	40.31	74	54	-15.99	-13.69
17059	V	57.12	38.9	74	54	-16.88	-15.1
4874	H	63.03	64.12	74	54	-10.97	10.12
7311	H	60.21	41.35	74	54	-13.79	-12.65
9688	H	58.6	41.31	74	54	-15.4	-12.69
12185	H	58.41	40.01	74	54	-15.59	-13.99
14622	H	58.23	39.41	74	54	-15.77	-14.59
17059	H	58.01	39.21	74	54	-15.99	-14.79

Operation Mode: 802.11 n20 Highest

Test Date : 2022-12-12

Test Voltage: AC 120V/60Hz

Test by: Sunshine

Freq. (MHz)	Ant. Pol. H/V	Emission Level(dBuV/m)		Limit 3m(dBuV/m)		Over(dB)	
		PK	AV	PK	AV	PK	AV
4924	V	63.23	43.11	74	54	-10.77	-10.89
7386	V	60.25	41.31	74	54	-13.75	-12.69
9848	V	58.18	40.01	74	54	-15.82	-13.99
12310	V	58.27	40.31	74	54	-15.73	-13.69
14772	V	58.14	39.08	74	54	-15.86	-14.92
17234	V	58.58	39.14	74	54	-15.42	-14.86
4924	H	62.15	43.58	74	54	-11.85	-10.42
7386	H	61.25	42.31	74	54	-12.75	-11.69
9848	H	59	40.15	74	54	-15	-13.85
12310	H	58.01	38.14	74	54	-15.99	-15.86
14772	H	58.28	39.14	74	54	-15.72	-14.86
17234	H	58.05	39.56	74	54	-15.95	-14.44

All emissions not reported were more than 20dB below the specified limit or in the noise floor.

No others harmonics emissions are higher than 20 dB below the limits of 47 CFR Part 15.247.

- Note:**
- (1) All Readings are Peak Value and AV.
 - (2) Emission Level= Reading Level+Probe Factor +Cable Loss.
 - (3) Data of measurement within this frequency range shown “ – ” in the table above means the reading of emissions are attenuated more than 20dB below the permissible limits or the field strength is too small to be measured.

8. 6dB Bandwidth Test

8.1 Measurement Procedure

The EUT was operating in IEEE 802.11b, 802.11g, 802.11n(HT20), 802.11n(HT40) mode or could be controlled its channel. Printed out the test result from the spectrum by hard copy function. The testing follows the Measurement Procedure of FCC KDB No. 558074 D01 15.247 Meas Guidance v05r02 .

1. Set resolution bandwidth (RBW) = 100 kHz.
2. Set the video bandwidth (VBW) $\geq 3 \times$ RBW.
3. Detector = Peak.
4. Trace mode = max hold.
5. Sweep = auto couple.
6. Allow the trace to stabilize.
7. Measure the maximum width of the emission that is constrained by the frequencies associated with the two outermost amplitude points (upper and lower frequency) that are attenuated by 6 dB relative to the maximum level measured in the fundamental emission.

8.2 Test SET-UP (Block Diagram of Configuration)

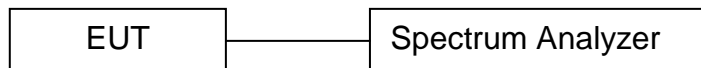

8.3 Measurement Equipment Used

Item	Instr.Code	Kind of Equipment	Manufacturer	Type No.	Serial No.	Calibrated until
1	AN-E037	Spectrum Analyzer	KEYSIGHT	N9020A	MY61250185	2023-10-07
2	AN-E040	WIDEBAND RADIO COMMUNICATION	Rohde & Schwarz	CMW500	157423	2023-10-07
3	AN-E039	MXG Vector Signal Generator	KEYSIGHT	N5182B	MY61250185	2023-10-07
4	AN-E038	EXG Analog Signal Generator	KEYSIGHT	N5173B	My61252603	2023-10-07
5	AN-E041	USB RF Power sensor	RadiPower	RPR3006W	17I00015SNO88	2023-10-07
6	AN-E042	USB RF Power sensor	RadiPower	RPR3006W	17I00015SNO89	2023-10-07
7	/	RF Test Software	MWRF-test	MTS 8310	N/A	N/A
8	AN-E092	Radio Frequency control box	MWRF-test	MW200-RFCB	MW220111ANCI	2023-05-12
9	AN-E093	Radio Frequency control box	MWRF-test	MW200-RFCB 2#	/	2023-05-12

Remark: The temporary antenna connector is soldered on the PCB board in order to perform conducted tests and this temporary antenna connector is listed in the equipment list.

8.4 Measurement Results

6db Bandwidth Test Data Chart:

Refer to attached data chart.

Spectrum Detector: PK Test Date : 2022-12-12
 Test By: Sunshine Temperature : 26°C
 Humidity : 60%

Mode	Frequency (MHz)	Antenna	-6 dB Bandwidth (MHz)	Limit -6 dB Bandwidth (MHz)	Verdict
b	2412	Ant1	9.069	0.5	Pass
b	2437	Ant1	9.078	0.5	Pass
b	2462	Ant1	9.069	0.5	Pass
g	2412	Ant1	16.347	0.5	Pass
g	2437	Ant1	16.347	0.5	Pass
g	2462	Ant1	16.341	0.5	Pass
n20	2412	Ant1	17.562	0.5	Pass
n20	2437	Ant1	17.586	0.5	Pass
n20	2462	Ant1	17.571	0.5	Pass

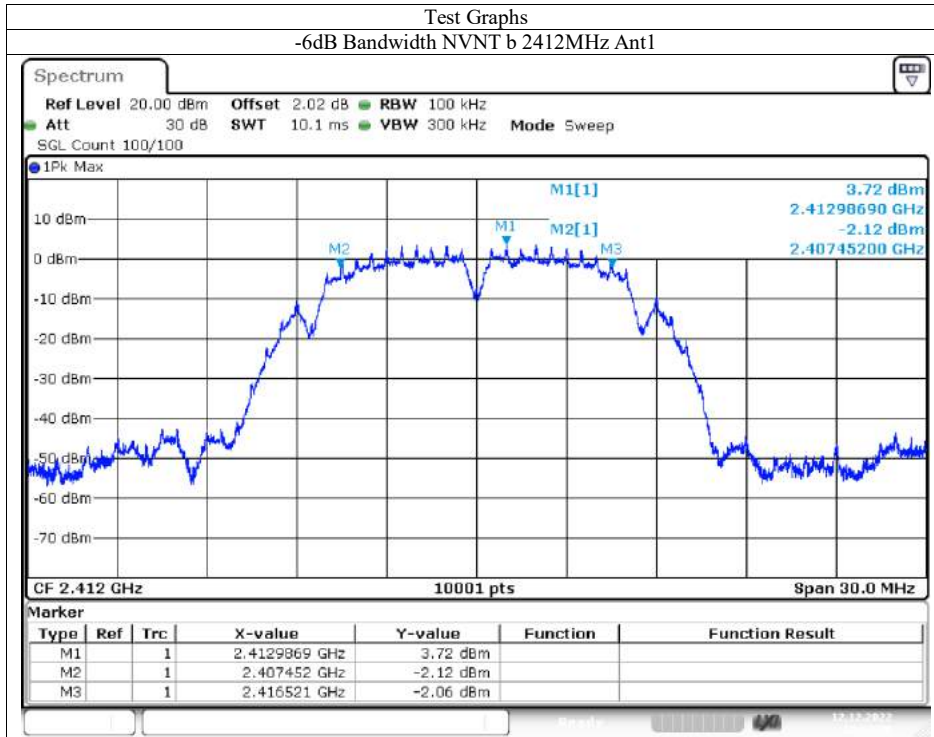

Date: 12.DEC.2022 10:12:37

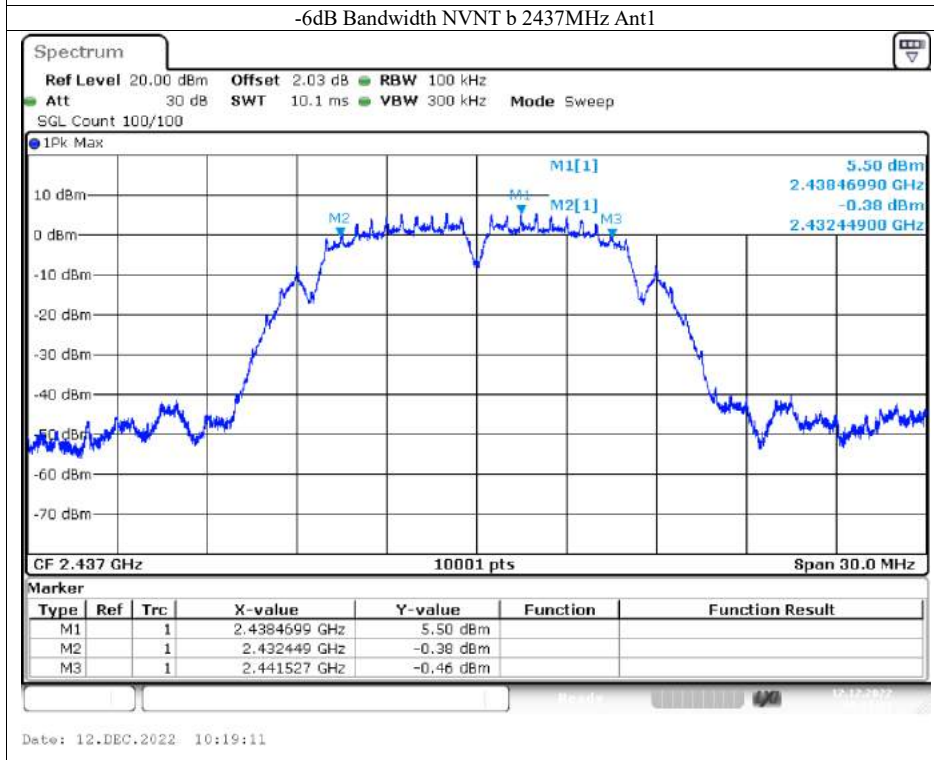

Date: 12.DEC.2022 10:19:11

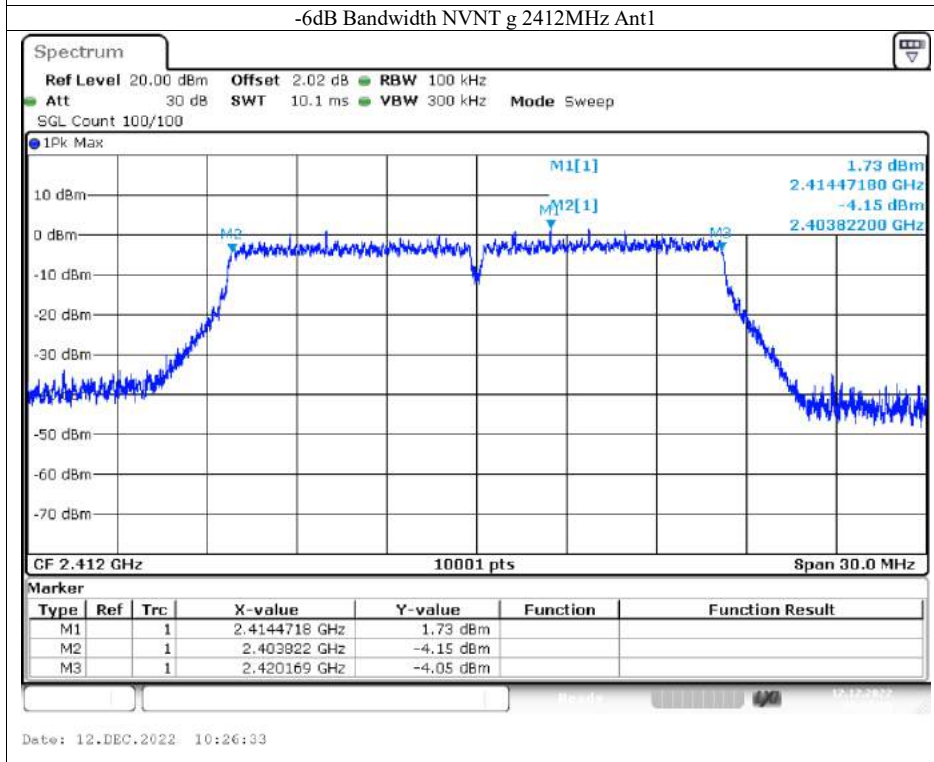
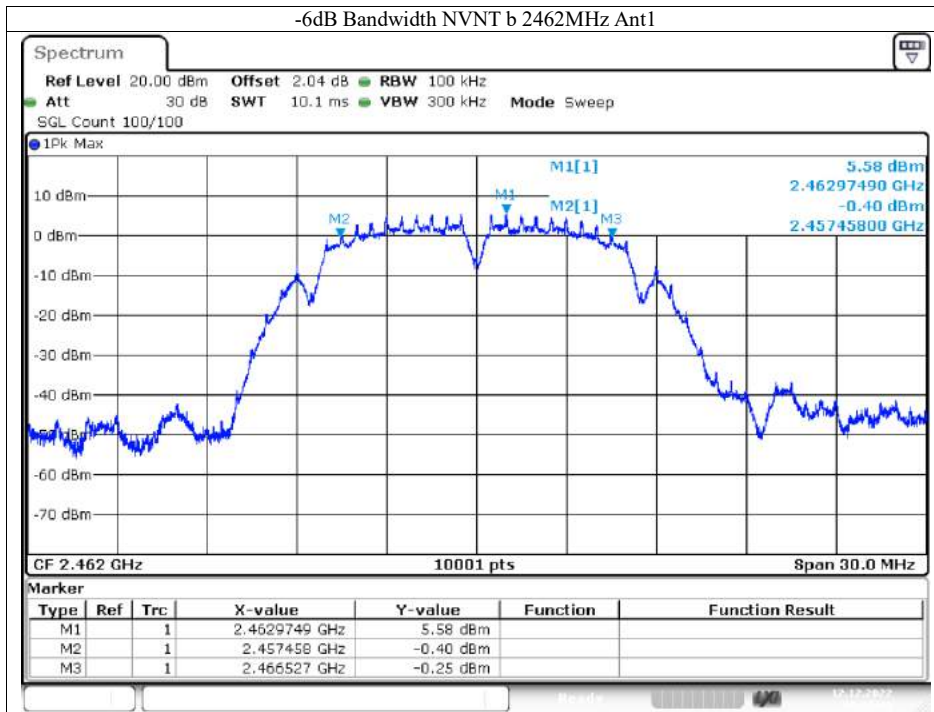

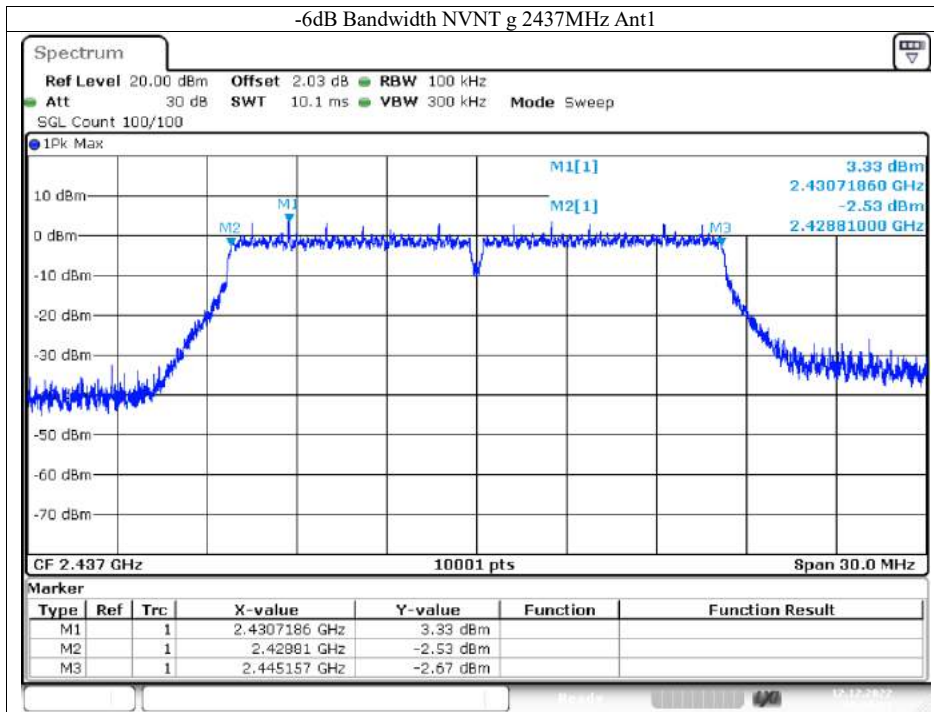

Date: 12.DEC.2022 10:30:31

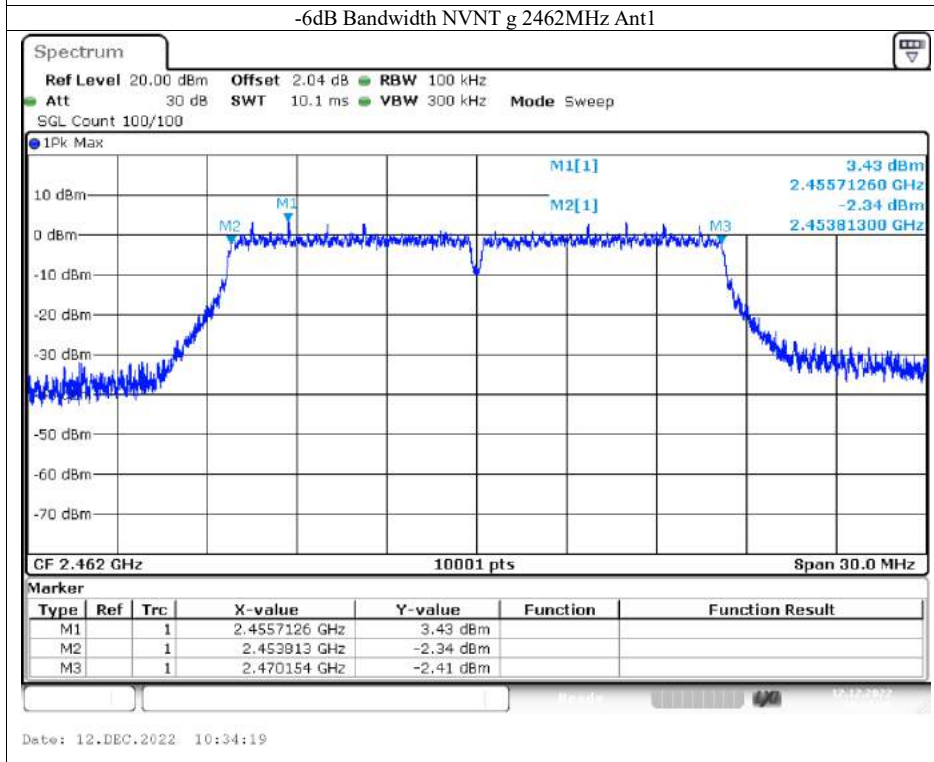

Date: 12.DEC.2022 10:34:19

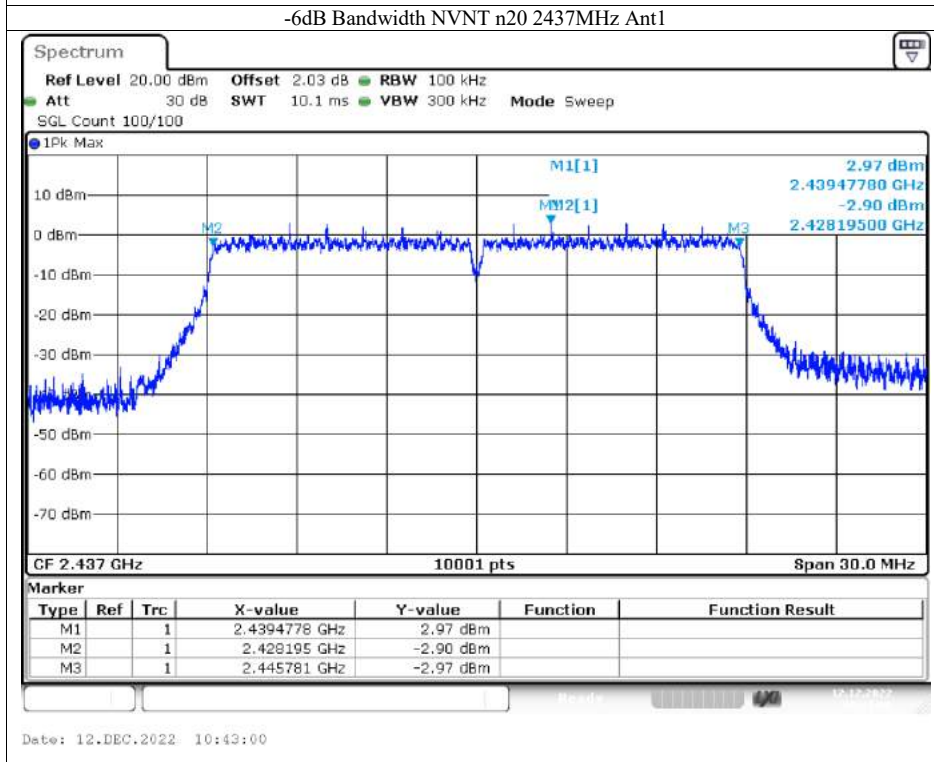
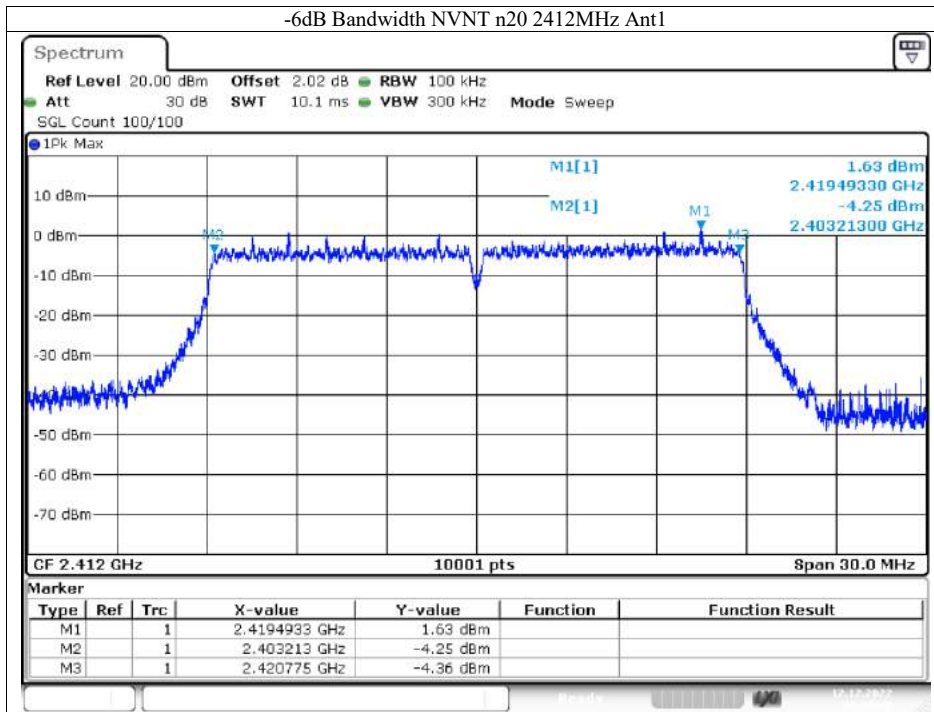

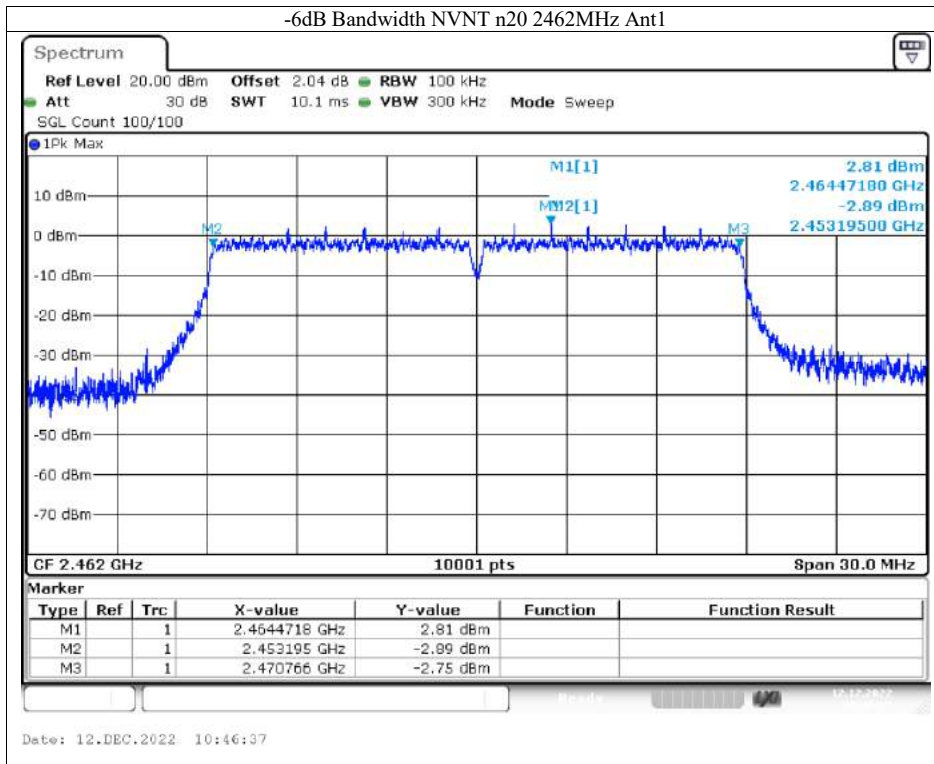

9. Maximum Peak Output Power Test

9.1 Measurement Procedure

1. The testing follows the Measurement Procedure of FCC KDB No. 558074 D01 15.247 Meas Guidance v05r02. The RF output of EUT was connected to the power meter by RF cable and attenuator. The path loss was compensated to the results for each measurement.
2. Set to the maximum power setting and enable the EUT transmit continuously.
3. Measure the conducted output power and record the results in the test report.

9.2 Test SET-UP (Block Diagram of Configuration)



9.3 Measurement Equipment Used

Remark: The temporary antenna connector is soldered on the PCB board in order to perform

Item	Instr.Code	Kind of Equipment	Manufacturer	Type No.	Serial No.	Calibrated until
1	AN-E037	Spectrum Analyzer	KEYSIGHT	N9020A	MY61250185	2023-10-07
2	AN-E040	WIDEBAND RADIO COMMUNICATION	Rohde & Schwarz	CMW500	157423	2023-10-07
3	AN-E039	MXG Vector Signal Generator	KEYSIGHT	N5182B	MY61250185	2023-10-07
4	AN-E038	EXG Analog Signal Generator	KEYSIGHT	N5173B	My61252603	2023-10-07
5	AN-E041	USB RF Power sensor	RadiPower	RPR3006W	17I00015SNO88	2023-10-07
6	AN-E042	USB RF Power sensor	RadiPower	RPR3006W	17I00015SNO89	2023-10-07
7	/	RF Test Software	MWRF-test	MTS 8310	N/A	N/A
8	AN-E092	Radio Frequency control box	MWRF-test	MW200-RFCB	MW220111ANCI	2023-05-12
9	AN-E093	Radio Frequency control box	MWRF-test	MW200-RFCB 2#	/	2023-05-12

conducted tests and this temporary antenna connector is listed in the equipment list.

9.4 Peak Power output limit

The maximum peak power shall be less 1Watt.

9.5 Measurement Results

Spectrum Detector:	PK	Test Date :	2022-12-12
Test By:	Sunshine	Temperature :	26°C
Test Result:	PASS	Humidity :	60%

Test Channel	Peak Output Power (dBm)			Limit(dBm)	Result
	802.11b	802.11g	802.11n(HT20)		
Lowest	13.22	13.73	13.11	30	Pass
Middle	15.03	15.39	14.95		
Highest	15.12	15.37	14.97		

10. Band Edge Test

10.1 Measurement Procedure

For Conducted Test

1. The testing follows FCC KDB Publication No. 5558074 D01 15.247 Meas Guidance v05r02.
2. The RF output of EUT was connected to the spectrum analyzer by RF cable and attenuator. The path loss was compensated to the results for each measurement.
3. Set to the maximum power setting and enable the EUT transmit continuously.
4. Set RBW = 100 kHz, VBW=300 kHz, Peak Detector. Unwanted Emissions measured in any 100 kHz bandwidth outside of the authorized frequency band shall be attenuated by at least 20 dB relative to the maximum in-band peak PSD level in 100 kHz when maximum peak conducted output power procedure is used. Measure and record the results in the test report.
5. The RF fundamental frequency should be excluded against the limit line in the operating frequency band.

For Radiated emission Test

1. The testing follows FCC KDB Publication No. 5558074 D01 15.247 Meas Guidance v05r02.
2. The EUT was arranged to its worst case and then tune the antenna tower (from 1 m to 4 m) and turntable (from 0 degree to 360 degrees) to find the maximum reading. A pre-amp and a high pass filter are used for the test in order to get better signal level.
3. The EUT was placed on a turntable with 0.8 meter above ground.
4. The EUT was set 3 meters from the interference receiving antenna, which was mounted on the top of a variable height antenna tower.
5. Corrected Reading: Antenna Factor + Cable Loss + Read Level - Preamp Factor = Level.
6. For measurement below 1GHz, If the emission level of the EUT measured by the peak detector is 3 dB lower than the applicable limit, the peak emission level will be reported. Otherwise, the emission measurement will be repeated using the quasi-peak detector and reported.
7. Repeat above procedures until all frequency measured were complete.

When spectrum scanned above 1GHz setting resolution bandwidth 1MHz, video bandwidth 3MHz.

EMI Test Receiver	Setting
Attenuation	Auto
RB	1MHz
VB	3MHz
Detector	Peak
Trace	Max hold

When spectrum scanned above 1GHz setting resolution bandwidth 1MHz, video bandwidth 10Hz.

EMI Test Receiver	Setting
Attenuation	Auto
RB	1MHz
VB	10Hz
Detector	AVG
Trace	Max hold

10.2 Test SET-UP (Block Diagram of Configuration)

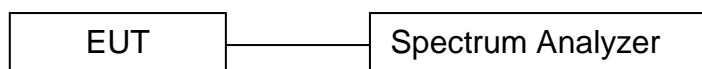

10.3 Measurement Equipment Used

Remark: The temporary antenna connector is soldered on the PCB board in order to perform

Item	Instr.Code	Kind of Equipment	Manufacturer	Type No.	Serial No.	Calibrated until
1	AN-E037	Spectrum Analyzer	KEYSIGHT	N9020A	MY61250185	2023-10-07
2	AN-E040	WIDEBAND RADIO COMMUNICATION	Rohde & Schwarz	CMW500	157423	2023-10-07
3	AN-E039	MXG Vector Signal Generator	KEYSIGHT	N5182B	MY61250185	2023-10-07
4	AN-E038	EXG Analog Signal Generator	KEYSIGHT	N5173B	My61252603	2023-10-07
5	AN-E041	USB RF Power sensor	RadiPower	RPR3006W	17I00015SNO88	2023-10-07
6	AN-E042	USB RF Power sensor	RadiPower	RPR3006W	17I00015SNO89	2023-10-07
7	/	RF Test Software	MWRF-test	MTS 8310	N/A	N/A
8	AN-E092	Radio Frequency control box	MWRF-test	MW200-RFCB	MW220111ANCI	2023-05-12
9	AN-E093	Radio Frequency control box	MWRF-test	MW200-RFCB 2#	/	2023-05-12

conducted tests and this temporary antenna connector is listed in the equipment list.

10.4 Measurement Results

1. Conducted Test

Spectrum Detector: PK Test Date : 2022-12-12
Test By: Sunshine Temperature : 26°C
Humidity : 60%

Mode	Frequency (MHz)	Antenna	Max Value (dBc)	Limit (dBc)	Verdict
b	2412	Ant1	-50.86	-20	Pass
b	2462	Ant1	-54.53	-20	Pass
g	2412	Ant1	-37.91	-20	Pass
g	2462	Ant1	-42.15	-20	Pass
n20	2412	Ant1	-36.3	-20	Pass
n20	2462	Ant1	-40.87	-20	Pass

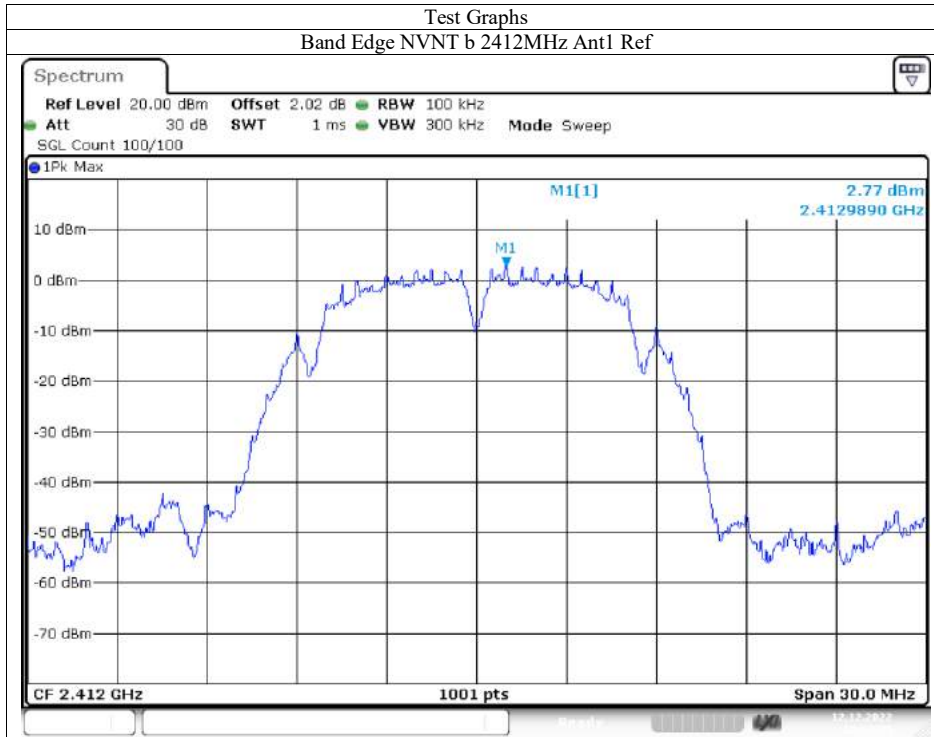

Date: 12.DEC.2022 10:14:35

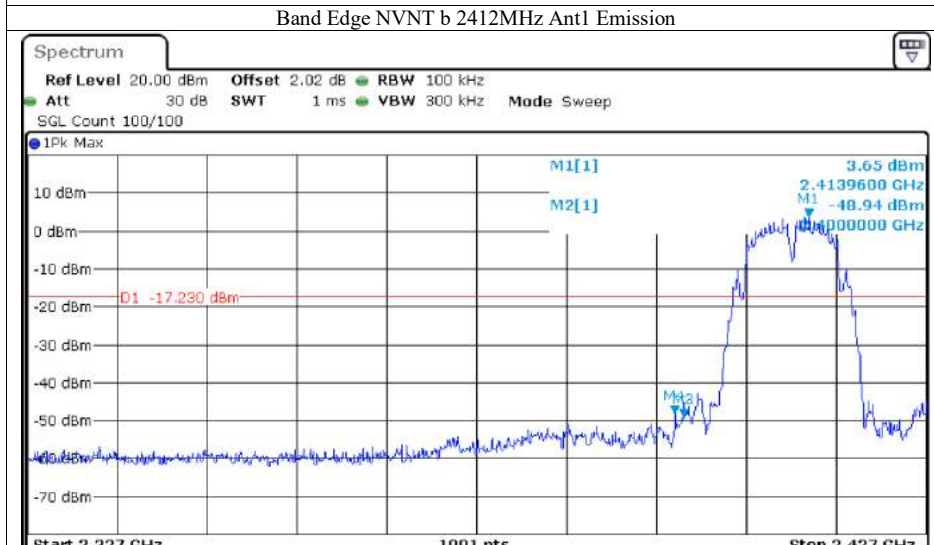

Marker

Type	Ref	Trc	X-value	Y-value	Function	Function Result
M1		1	2.41396 GHz	3.65 dBm		
M2		1	2.4 GHz	-48.94 dBm		
M3		1	2.4 GHz	-48.94 dBm		
M4		1	2.399 GHz	-48.09 dBm		

Date: 12.DEC.2022 10:14:39

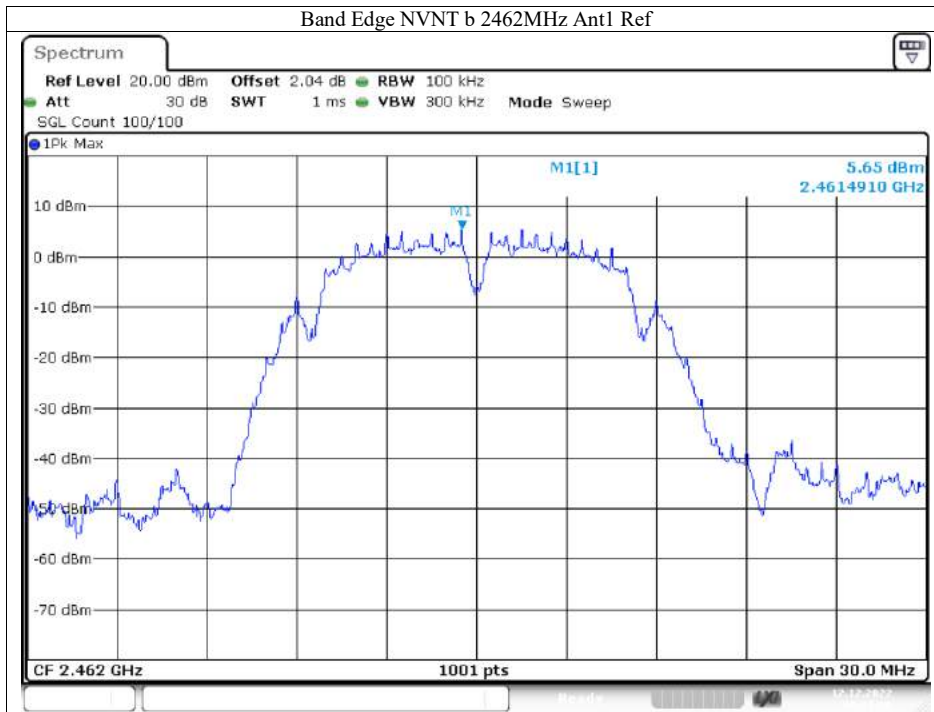

Date: 12.DEC.2022 10:23:30

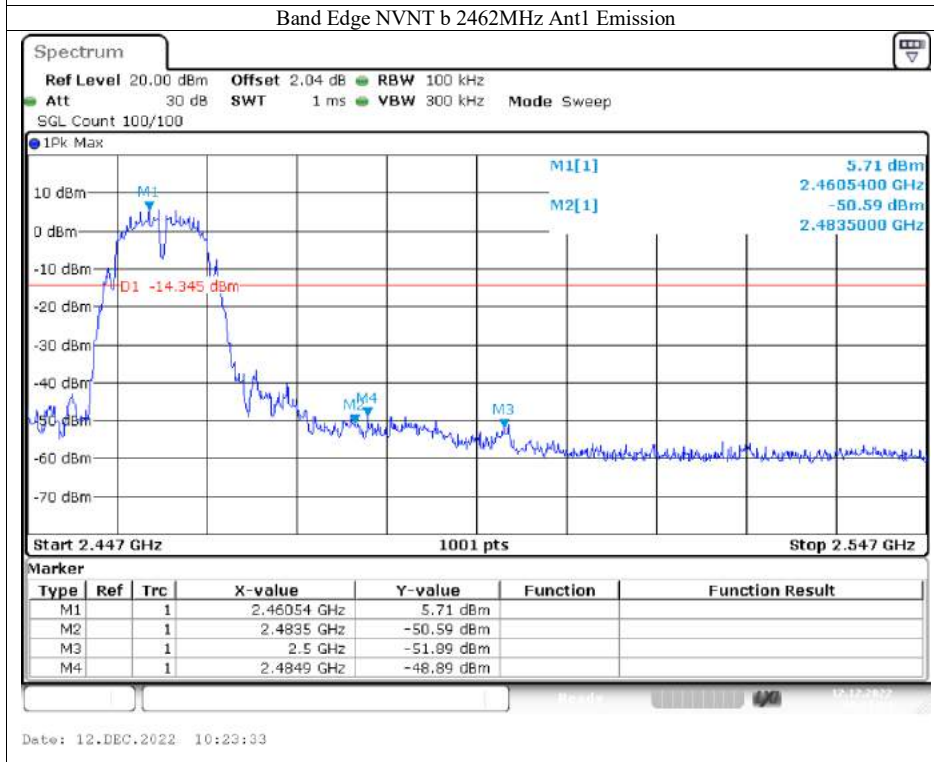

Date: 12.DEC.2022 10:23:33

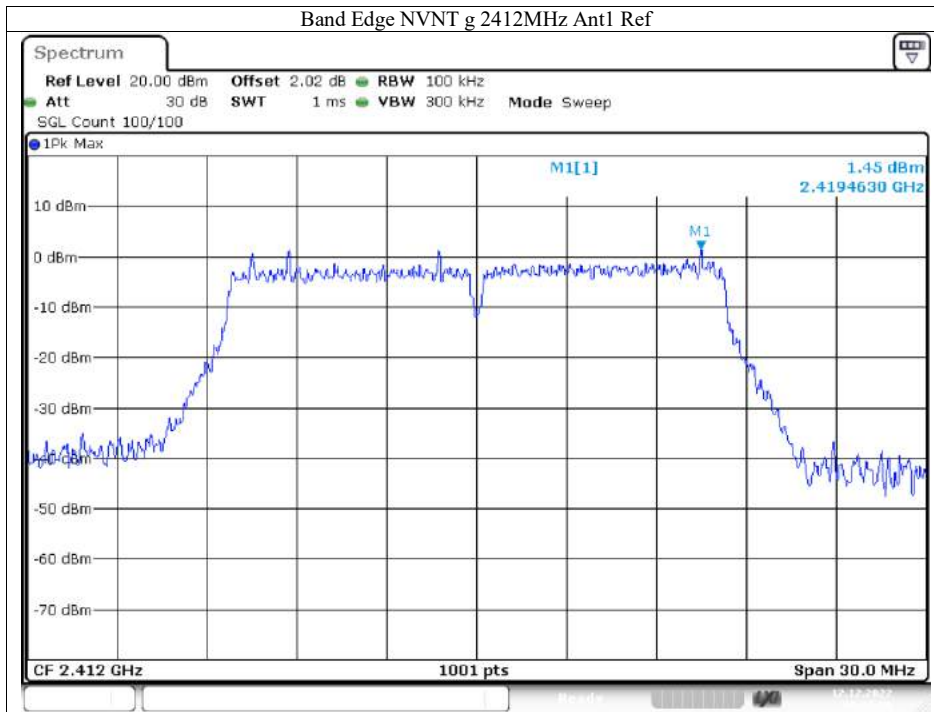

Date: 12.DEC.2022 10:27:59

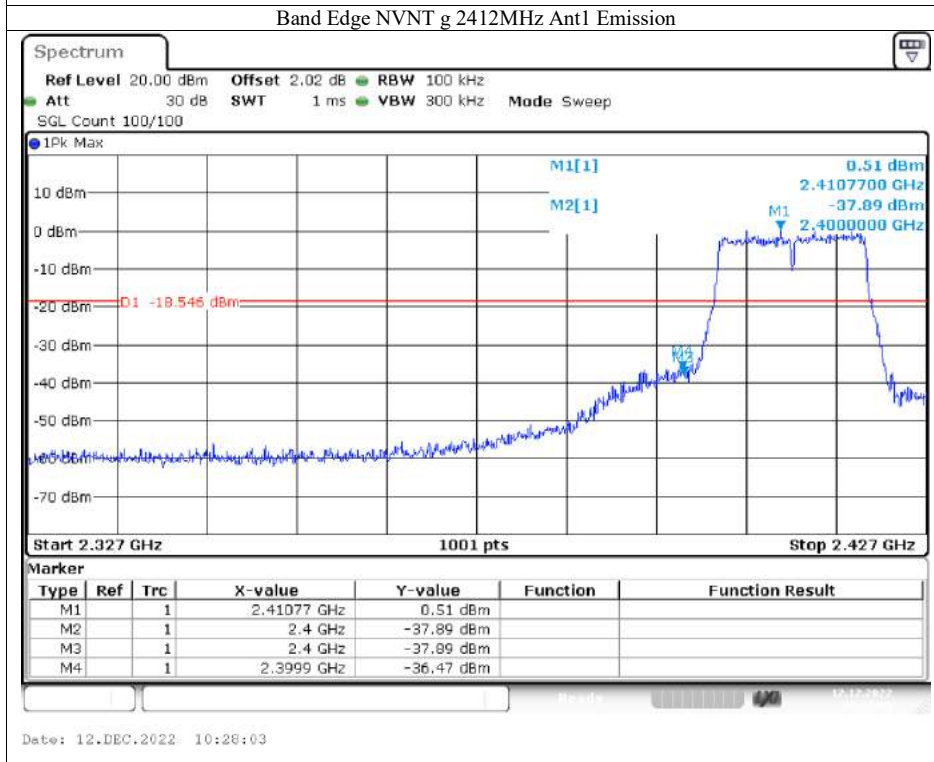

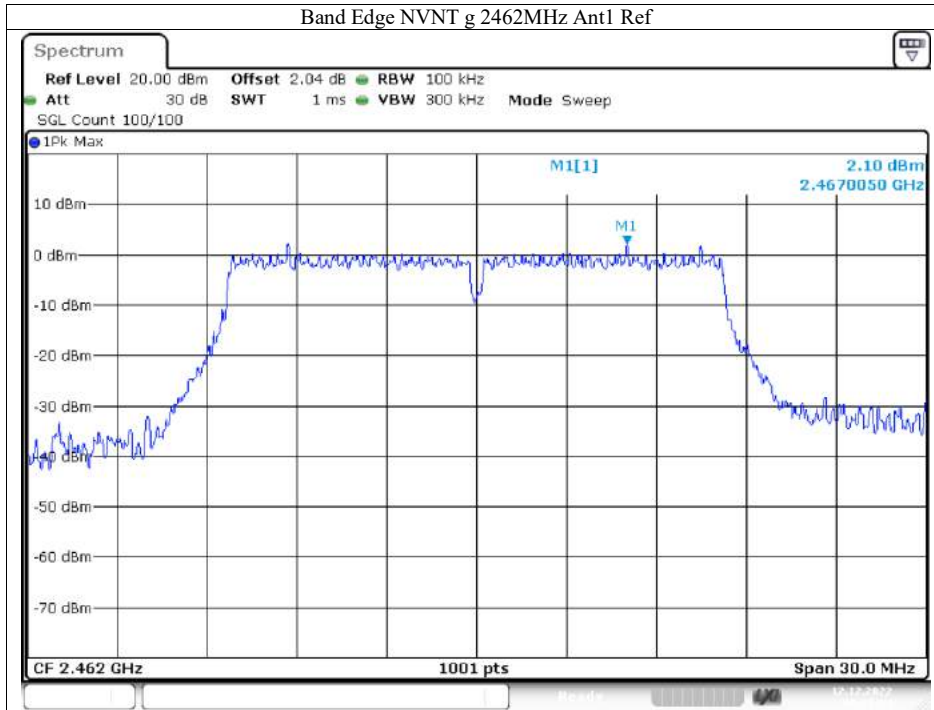

Date: 12.DEC.2022 10:35:23

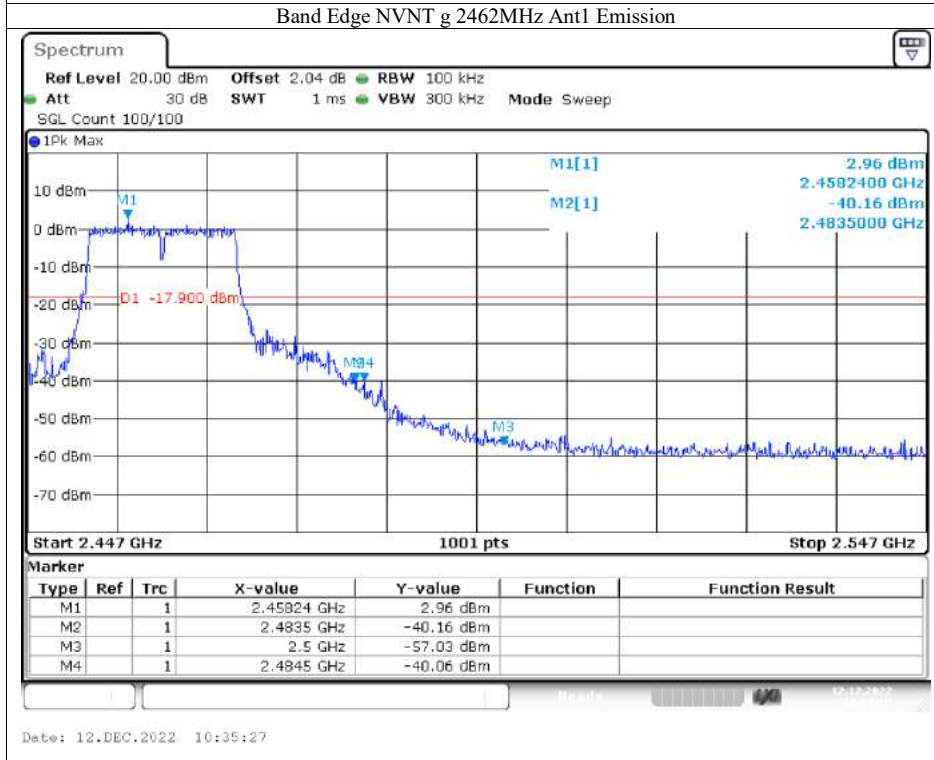

Date: 12.DEC.2022 10:35:27

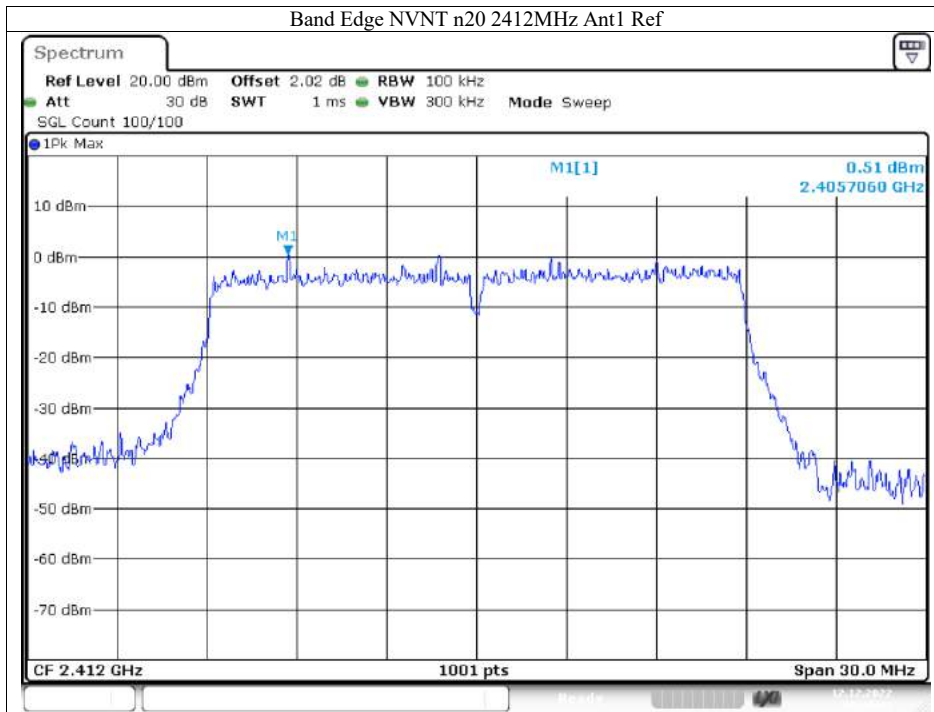

Date: 12.DEC.2022 10:40:41

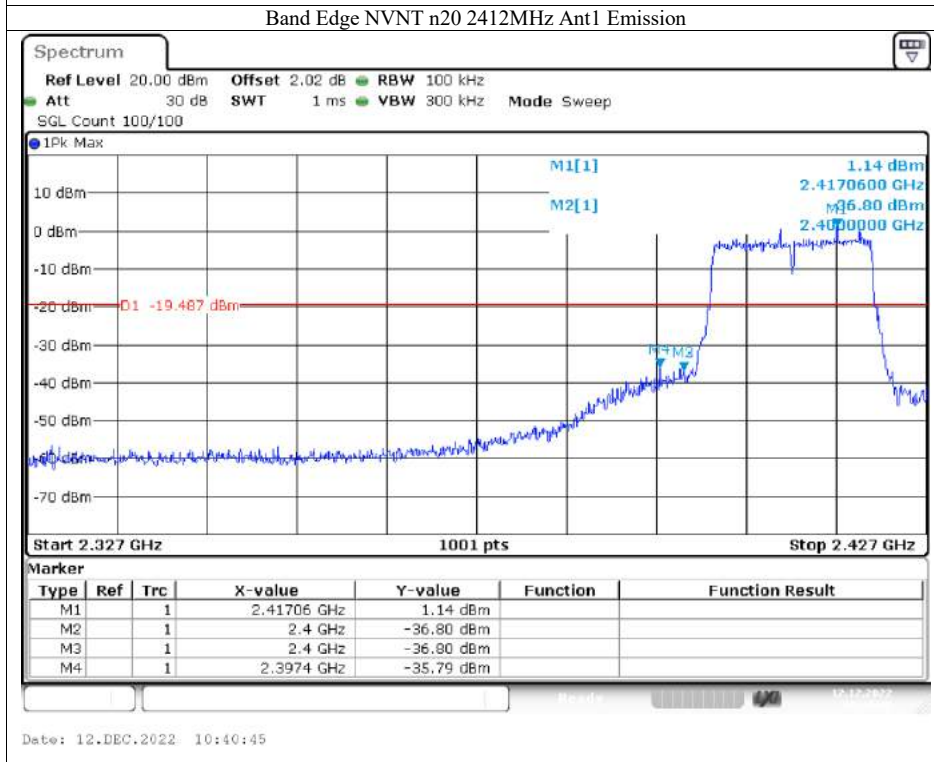

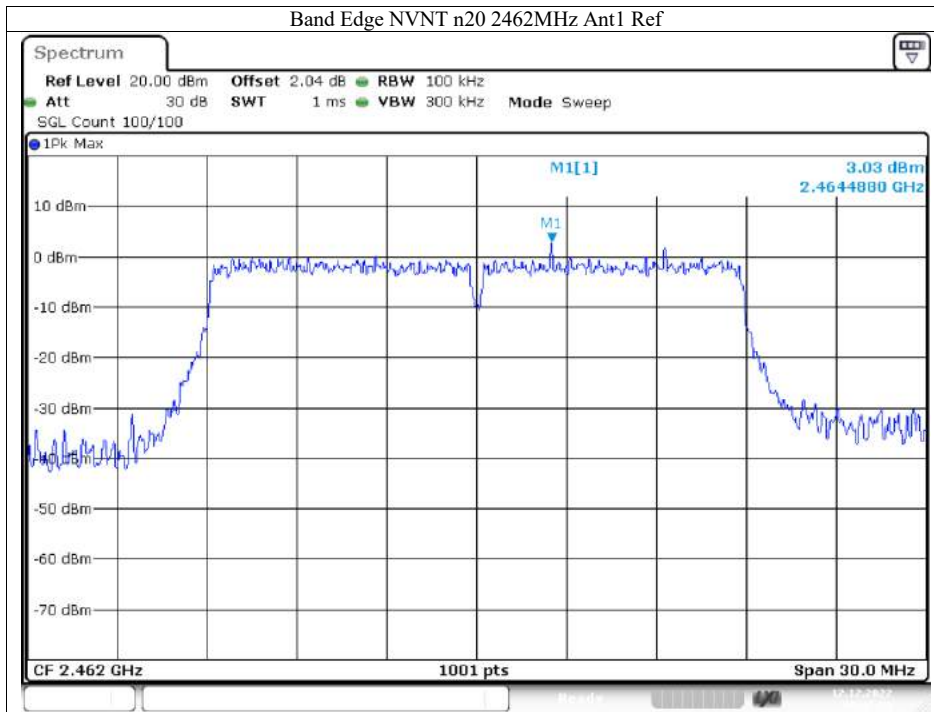

Date: 12.DEC.2022 10:47:53

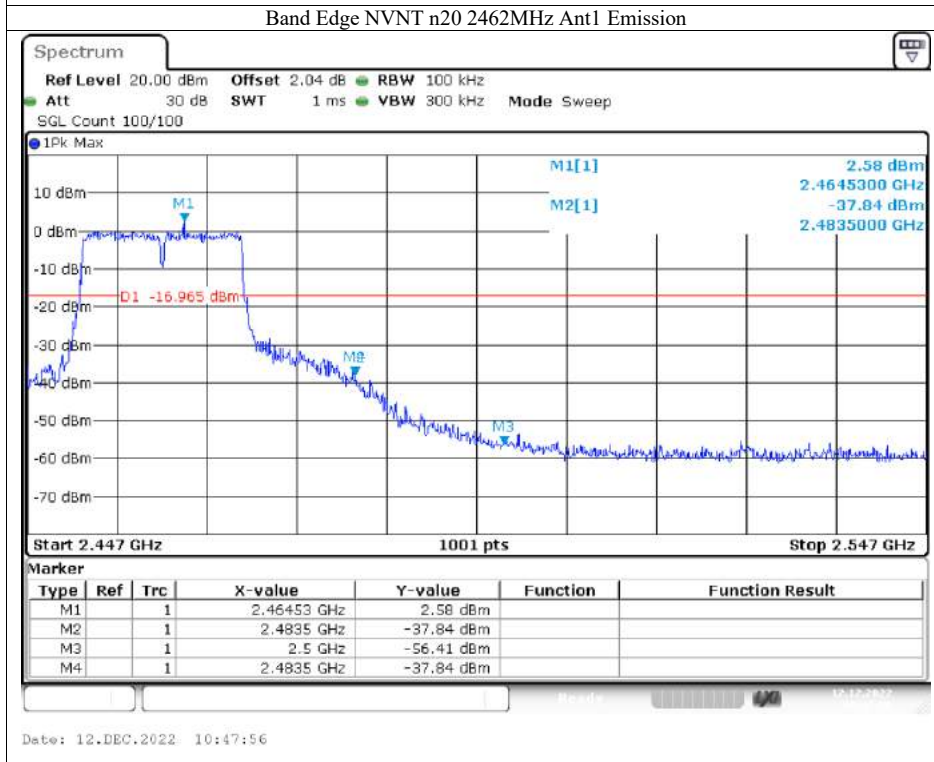

11. Power Density

11.1 Test Equipment

Remark: The temporary antenna connector is soldered on the PCB board in order to perform

Item	Instr.Code	Kind of Equipment	Manufacturer	Type No.	Serial No.	Calibrated until
1	AN-E037	Spectrum Analyzer	KEYSIGHT	N9020A	MY61250185	2023-10-07
2	AN-E040	WIDEBAND RADIO COMMUNICATION	Rohde & Schwarz	CMW500	157423	2023-10-07
3	AN-E039	MXG Vector Signal Generator	KEYSIGHT	N5182B	MY61250185	2023-10-07
4	AN-E038	EXG Analog Signal Generator	KEYSIGHT	N5173B	My61252603	2023-10-07
5	AN-E041	USB RF Power sensor	RadiPower	RPR3006W	17100015SNO88	2023-10-07
6	AN-E042	USB RF Power sensor	RadiPower	RPR3006W	17100015SNO89	2023-10-07
7	/	RF Test Software	MWRF-test	MTS 8310	N/A	N/A
8	AN-E092	Radio Frequency control box	MWRF-test	MW200-RFCB	MW220111ANCI	2023-05-12
9	AN-E093	Radio Frequency control box	MWRF-test	MW200-RFCB 2#	/	2023-05-12

conducted tests and this temporary antenna connector is listed in the equipment list.

11.2 Measuring Instruments and Setting

The following table is the setting of spectrum analyzer.

Spectrum analyzer	Setting
Attenuation	Auto
Span Frequency	Set the span to 1.5 times the DTS bandwidth.
RB	3kHz
VB	10KHz
Detector	Peak
Trace	Max hold
Sweep Time	Automatic

11.3 Test Procedures

The testing follows the Measurement Procedure of FCC KDB No. 558074 D01 15.247 Meas Guidance v05r02.

- The transmitter output (antenna port) was connected to the spectrum analyzer.
- Set analyzer center frequency to DTS channel center frequency.
- Set the analyzer span to a minimum of 1.5 times the DTS bandwidth.
- Set the RBW \geq 3 kHz. Set the VBW \geq 3 x RBW.
- Detector = peak.
- Sweep time = auto couple.
- Trace mode = max hold.
- Allow trace to fully stabilize.
- Use the peak marker function to determine the maximum amplitude level.

11.4 Block Diagram of Test Setup

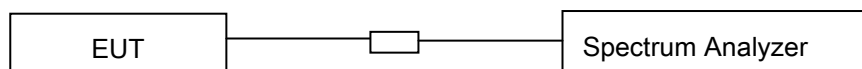

11.5 Limit

The transmitted power density averaged over any 1 second interval shall not be greater +8dBm in any 3 kHz bandwidth.

11.6 Test Result

Spectrum Detector: PK Test Date : 2022-12-12
 Test By: Sunshine Temperature : 26°C
 Test Result: PASS Humidity : 60%

Mode	Frequency (MHz)	Antenna	Conducted PSD (dBm/3kHz)	Duty Factor (dB)	Total PSD (dBm/3kHz)	Limit (dBm/3kHz)	Verdict
b	2412	Ant1	-9.82	0	-9.82	8	Pass
b	2437	Ant1	-8.27	0	-8.27	8	Pass
b	2462	Ant1	-7.67	0	-7.67	8	Pass
g	2412	Ant1	-10.59	0	-10.59	8	Pass
g	2437	Ant1	-8.49	0	-8.49	8	Pass
g	2462	Ant1	-9.26	0	-9.26	8	Pass
n20	2412	Ant1	-11.13	0	-11.13	8	Pass
n20	2437	Ant1	-10.38	0	-10.38	8	Pass
n20	2462	Ant1	-9.48	0	-9.48	8	Pass

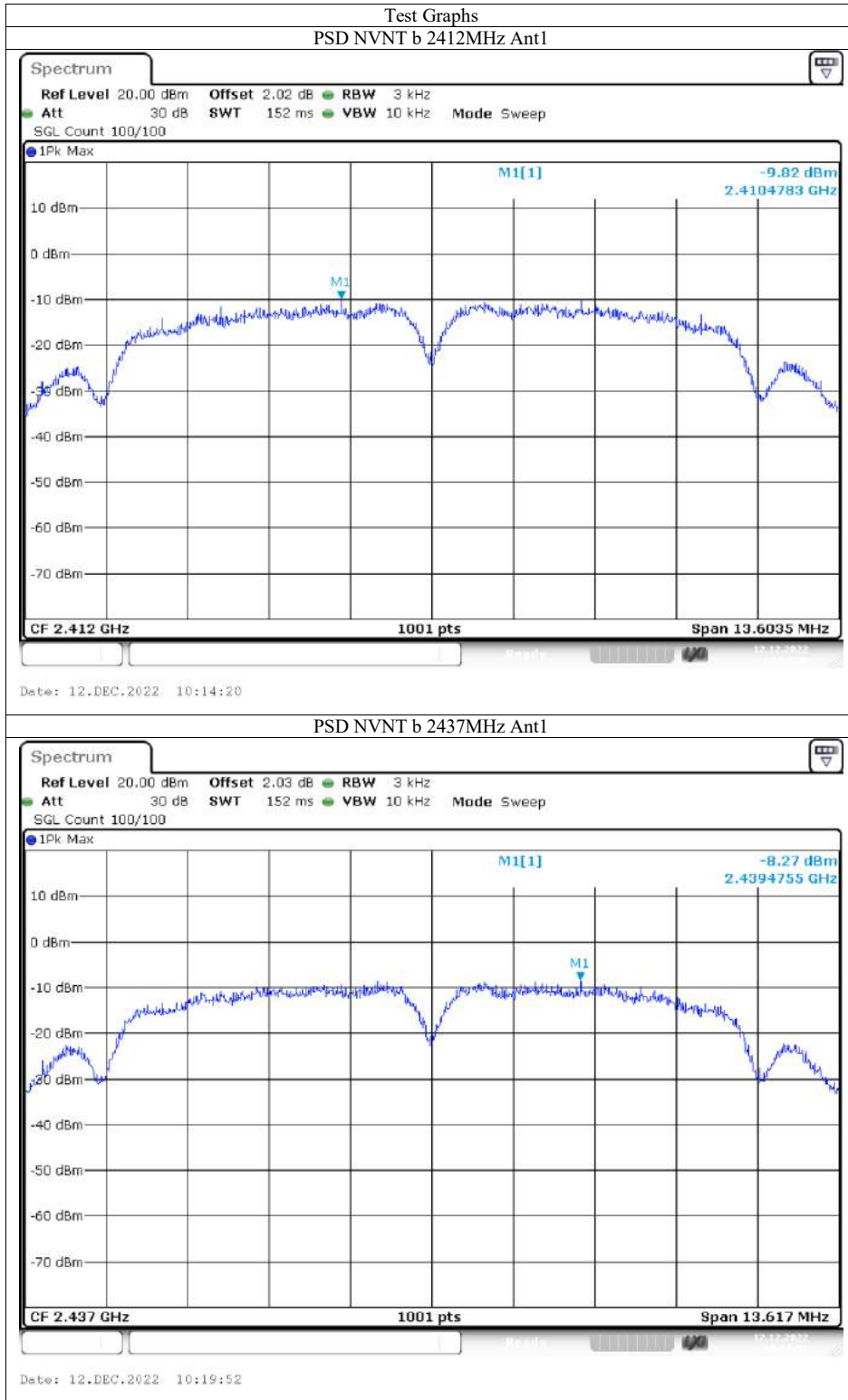

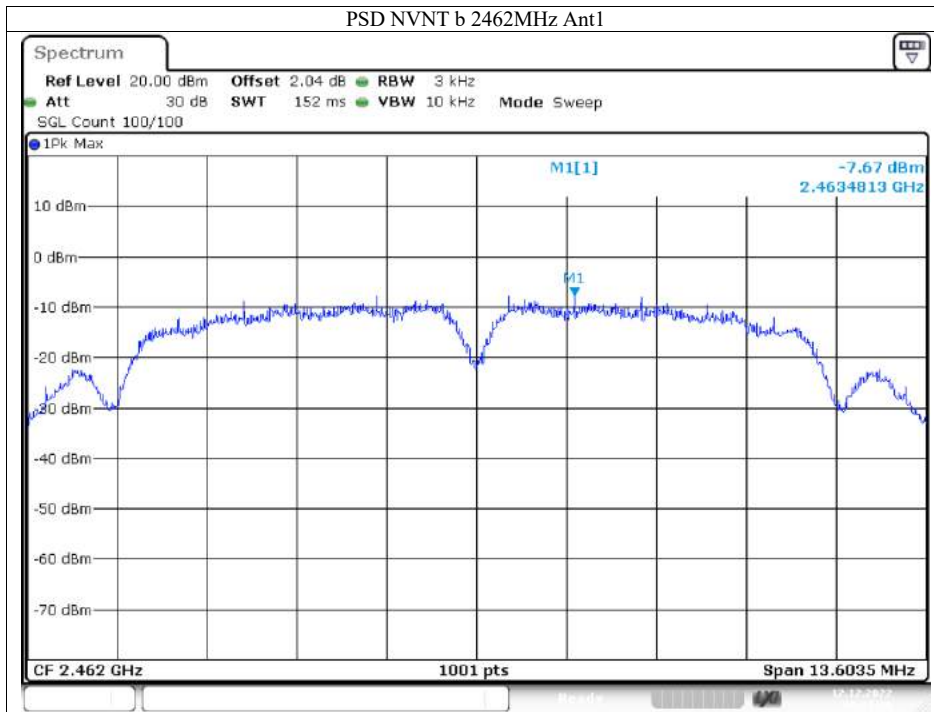

Date: 12.DEC.2022 10:23:19

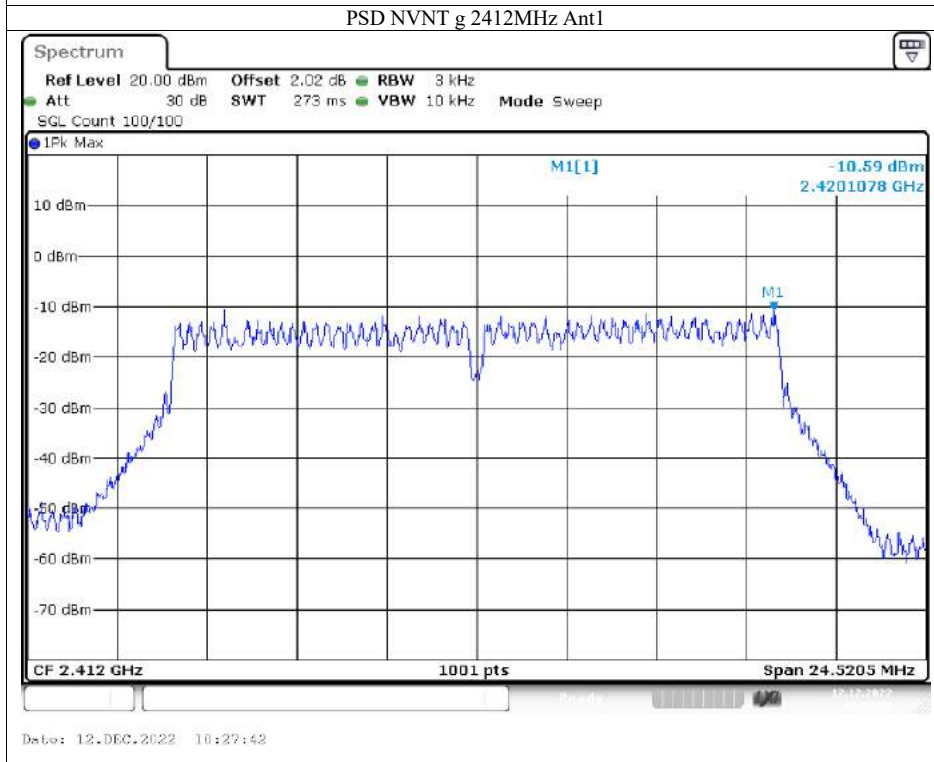

Date: 12.DEC.2022 10:27:42

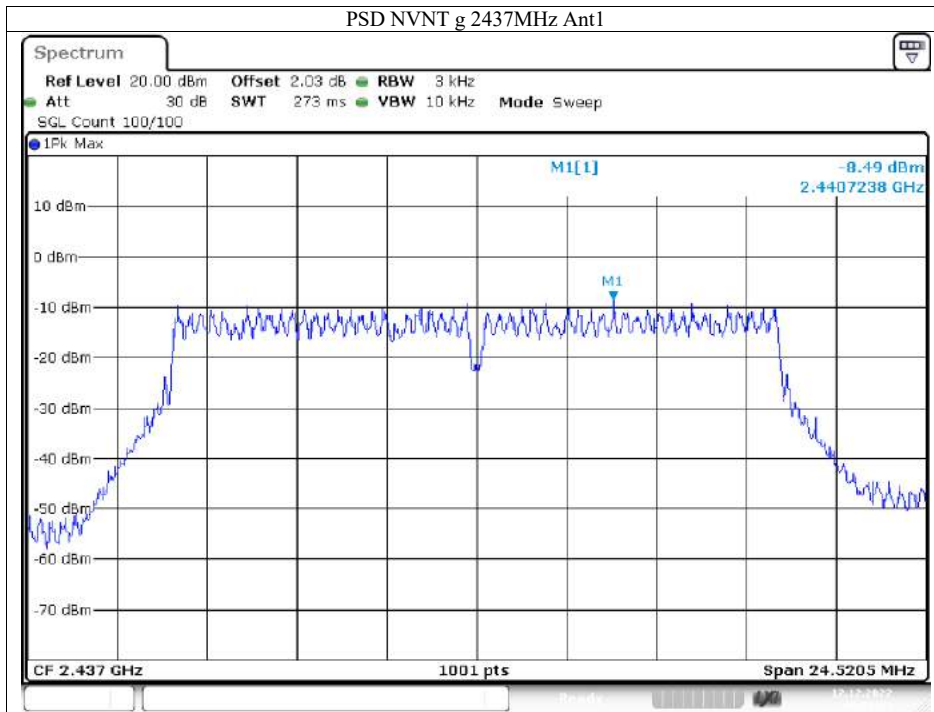

Date: 12.DEC.2022 10:32:13

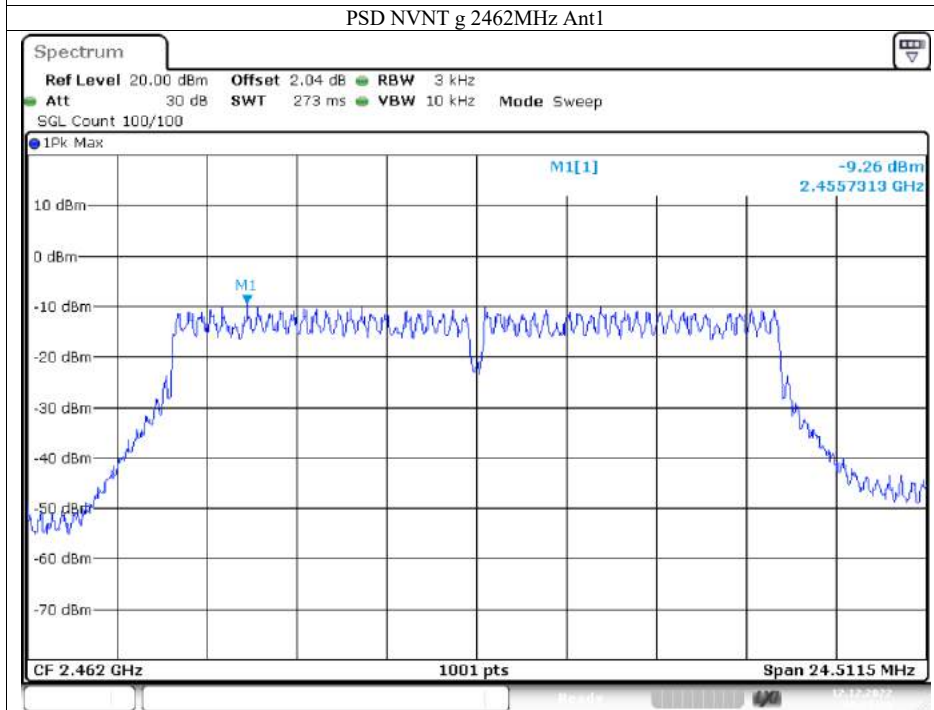

Date: 12.DEC.2022 10:35:13

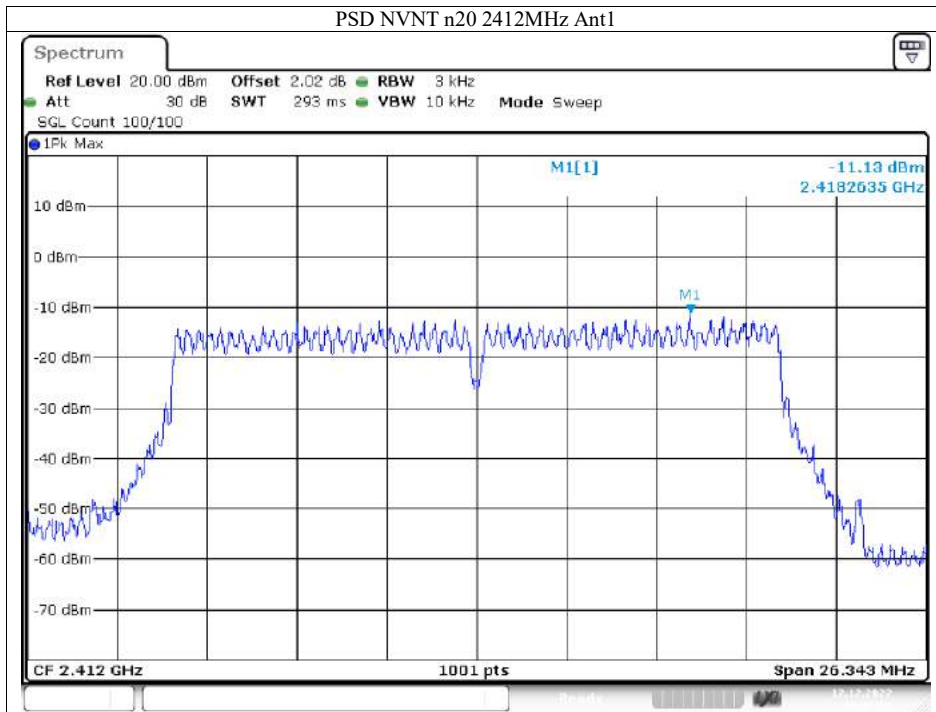

Date: 12.DEC.2022 10:40:26

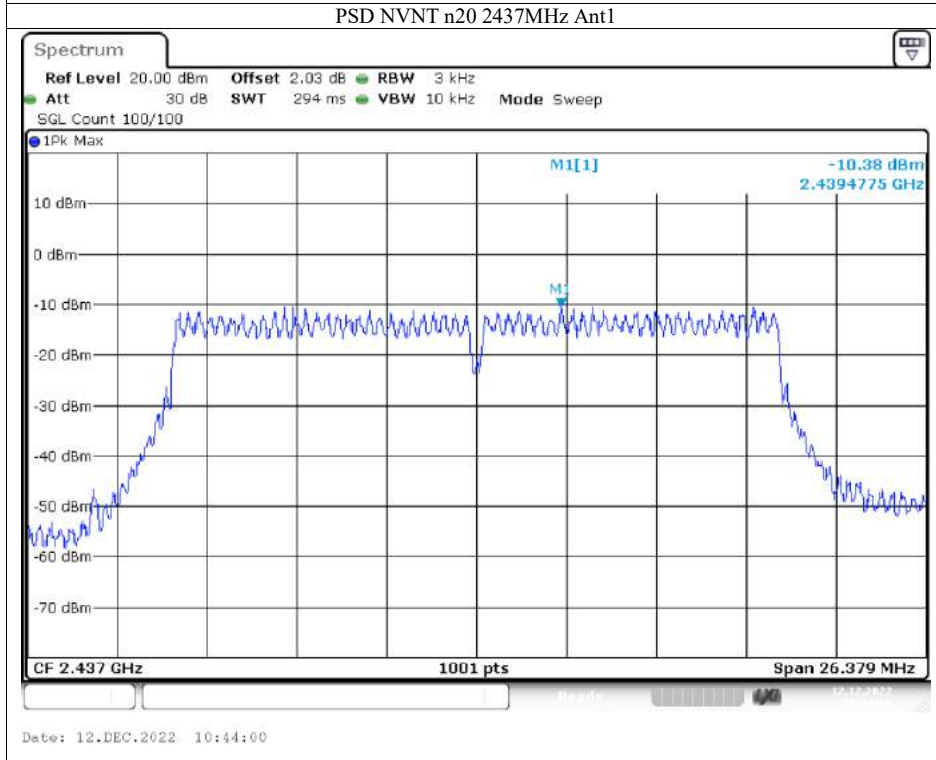

Date: 12.DEC.2022 10:44:00

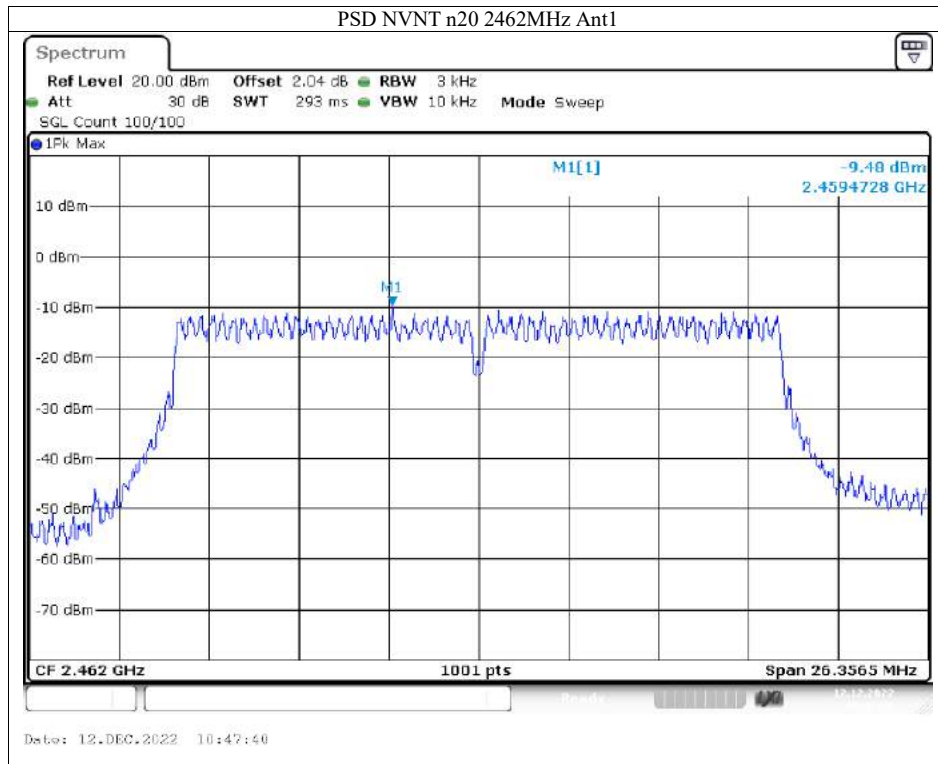

12. Antenna Port Emission

12.1 Test Equipment

Item	Instr.Code	Kind of Equipment	Manufacturer	Type No.	Serial No.	Calibrated until
1	AN-E037	Spectrum Analyzer	KEYSIGHT	N9020A	MY61250185	2023-10-07
2	AN-E040	WIDEBAND RADIO COMMUNICATION	Rohde & Schwarz	CMW500	157423	2023-10-07
3	AN-E039	MXG Vector Signal Generator	KEYSIGHT	N5182B	MY61250185	2023-10-07
4	AN-E038	EXG Analog Signal Generator	KEYSIGHT	N5173B	My61252603	2023-10-07
5	AN-E041	USB RF Power sensor	RadiPower	RPR3006W	17I00015SNO88	2023-10-07
6	AN-E042	USB RF Power sensor	RadiPower	RPR3006W	17I00015SNO89	2023-10-07
7	/	RF Test Software	MWRF-test	MTS 8310	N/A	N/A
8	AN-E092	Radio Frequency control box	MWRF-test	MW200-RFCB	MW220111ANCI	2023-05-12
9	AN-E093	Radio Frequency control box	MWRF-test	MW200-RFCB 2#	/	2023-05-12

Remark: The temporary antenna connector is soldered on the PCB board in order to perform conducted tests and this temporary antenna connector is listed in the equipment list.

12.2 Measuring Instruments and Setting

The following table is the setting of spectrum analyzer.

Spectrum analyzer	Setting
Attenuation	Auto
RB	100kHz
VB	300kHz
Detector	Peak
Trace	Max hold

12.3 Test Procedures

The testing follows the Measurement Procedure of FCC KDB No. 558074 D01 15.247 Meas Guidance v05r02 .

The conducted spurious emissions were measured conducted using a spectrum analyzer at low, Middle, and high channels, the limit was determined by attenuation 20dB of the RF peak power output.

12.4 Block Diagram of Test setup

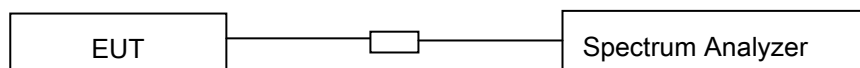

12.5 Test Result**PASS.**

Please refer to following pages.

Spectrum Detector: PK Test Date : 2022-12-12
 Test By: Sunshine Temperature : 26°C
 Test Result: PASS Humidity : 60%

Mode	Frequency (MHz)	Antenna	Max Value (dBc)	Limit (dBc)	Verdict
b	2412	Ant1	-39.21	-20	Pass
b	2437	Ant1	-39.87	-20	Pass
b	2462	Ant1	-41.97	-20	Pass
g	2412	Ant1	-45.95	-20	Pass
g	2437	Ant1	-44.3	-20	Pass
g	2462	Ant1	-48.32	-20	Pass
n20	2412	Ant1	-47.09	-20	Pass
n20	2437	Ant1	-44.87	-20	Pass
n20	2462	Ant1	-48.32	-20	Pass

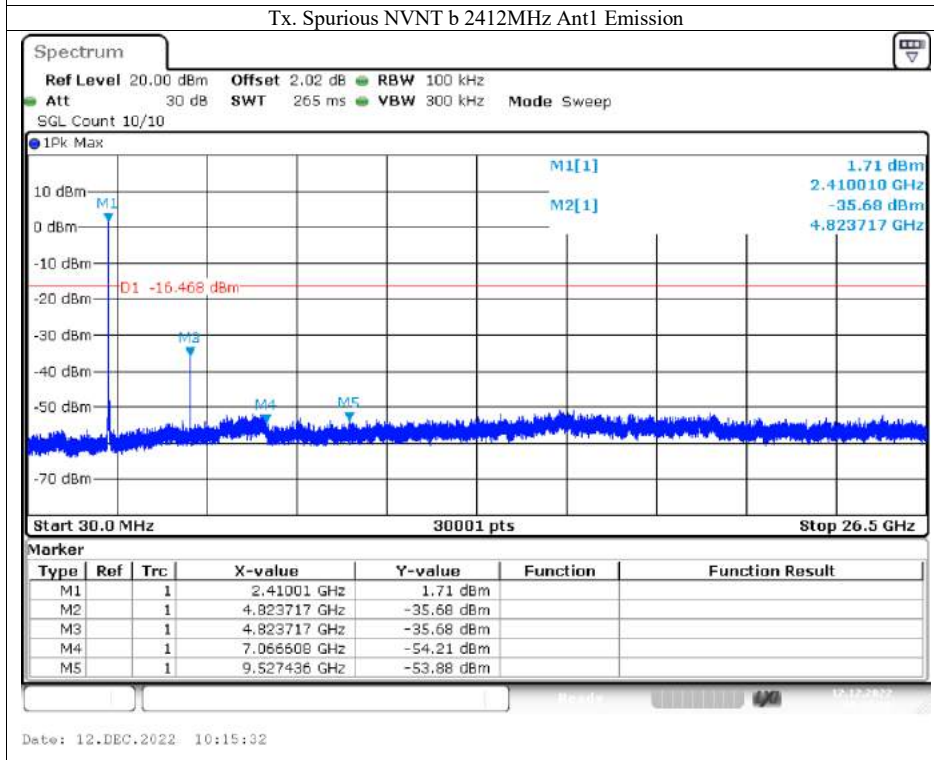
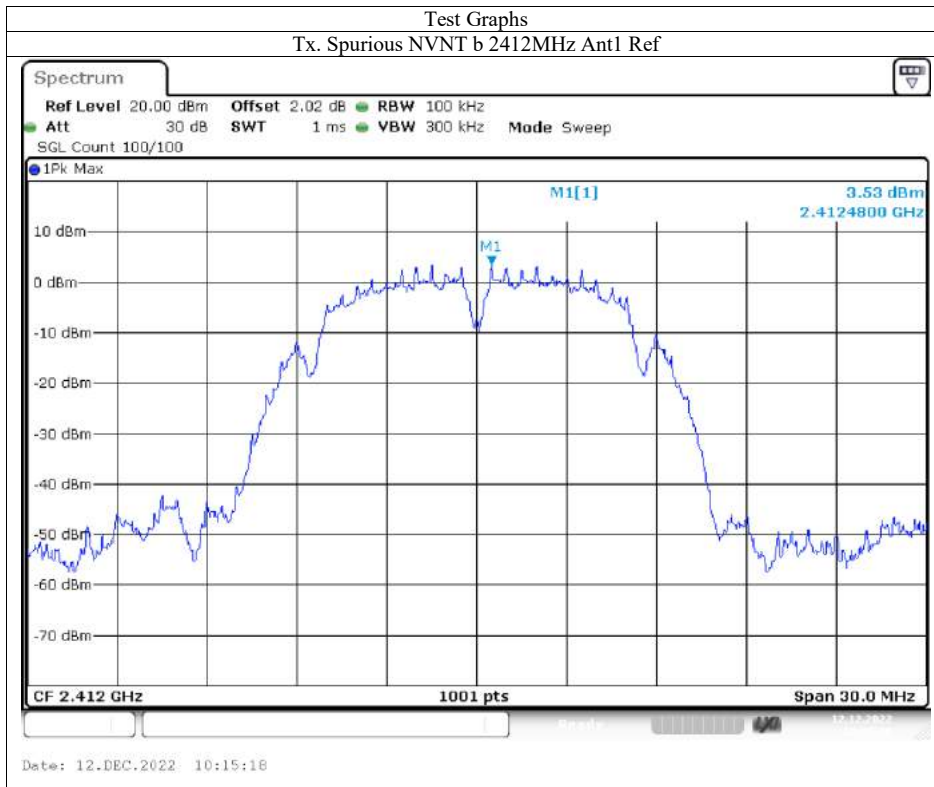

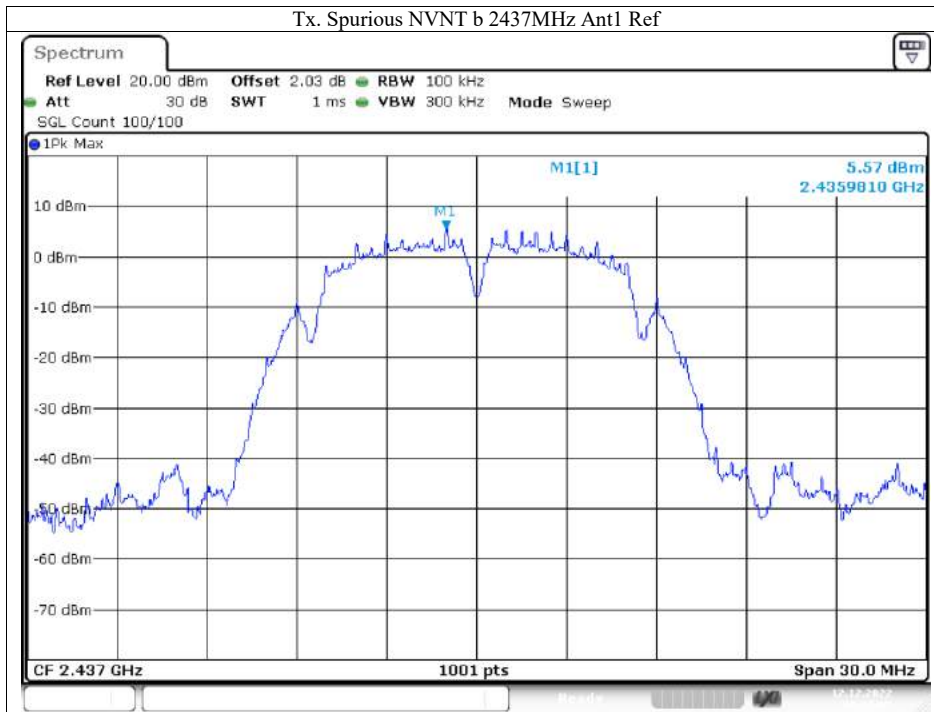

Date: 12.DEC.2022 10:20:07

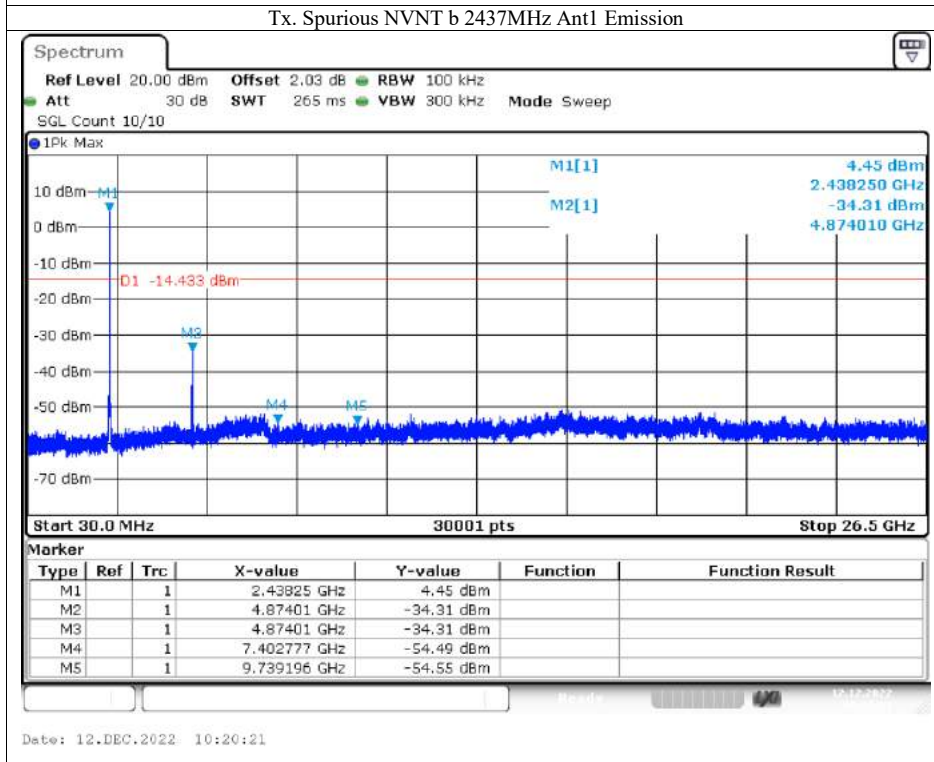

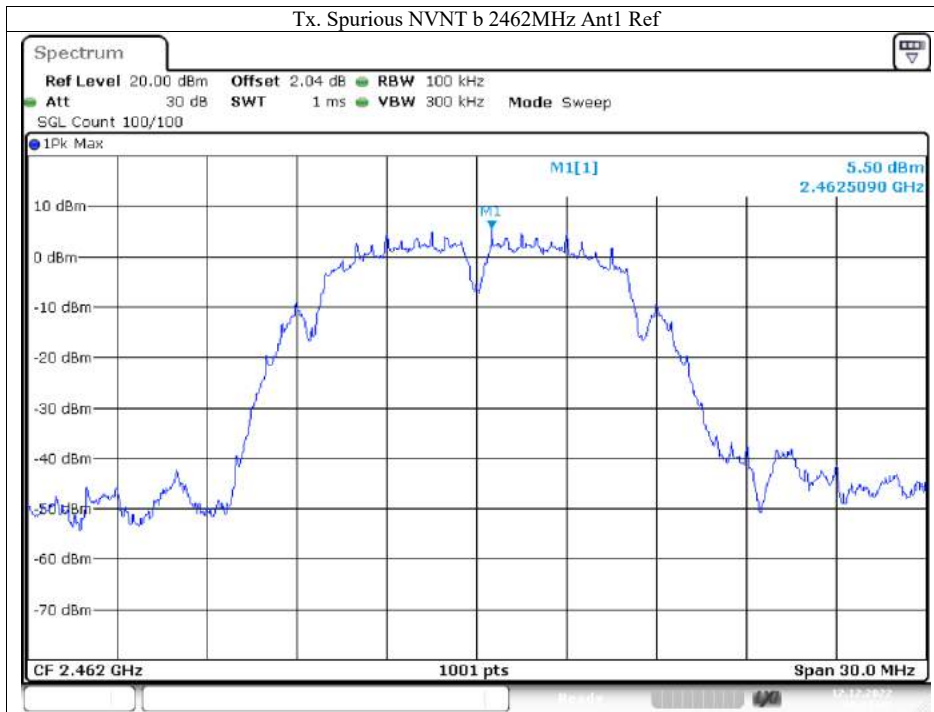

Date: 12.DEC.2022 10:23:47

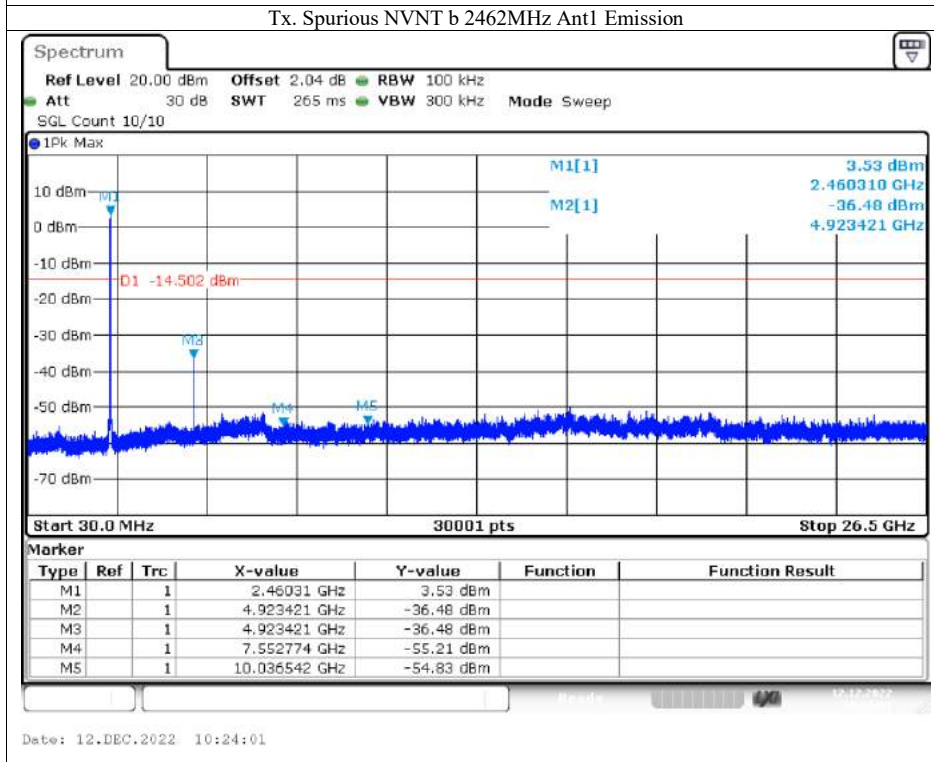

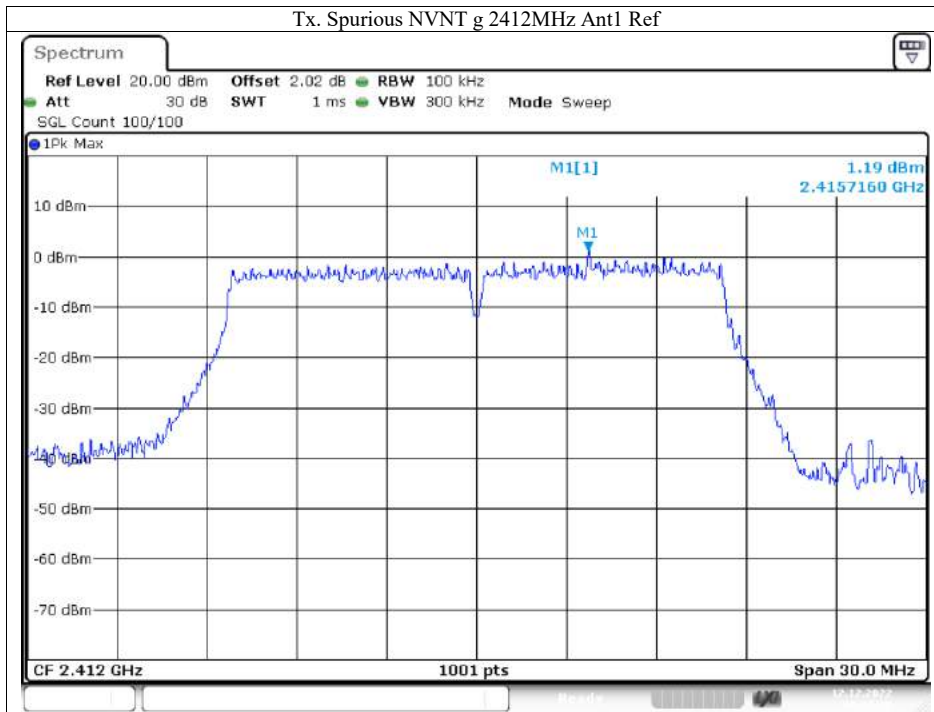

Date: 12.DEC.2022 10:28:15

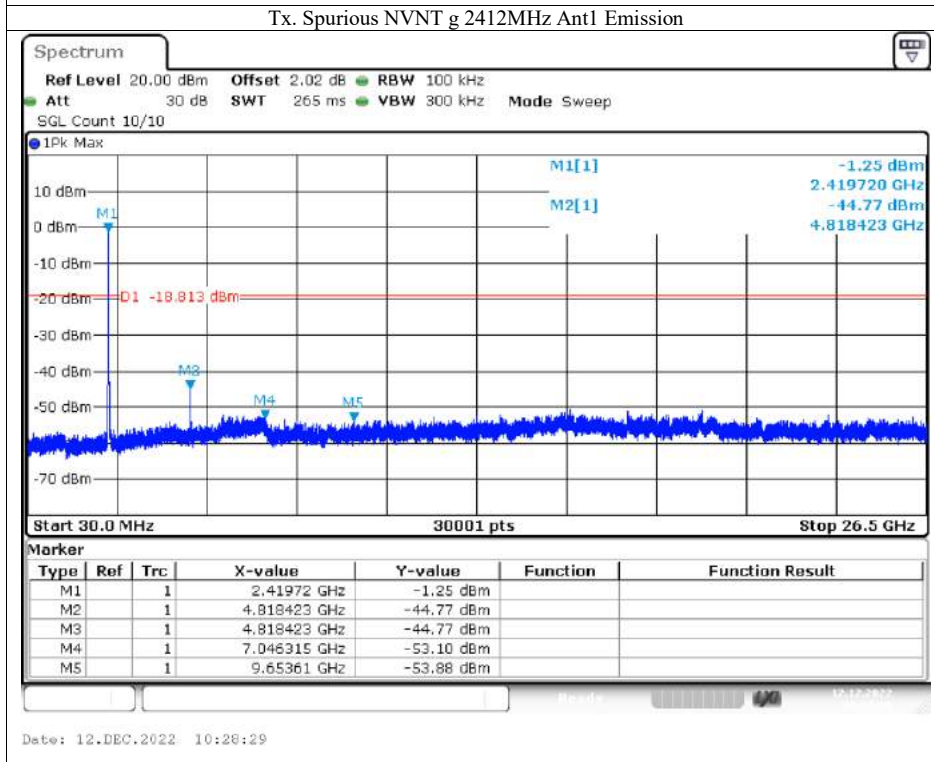

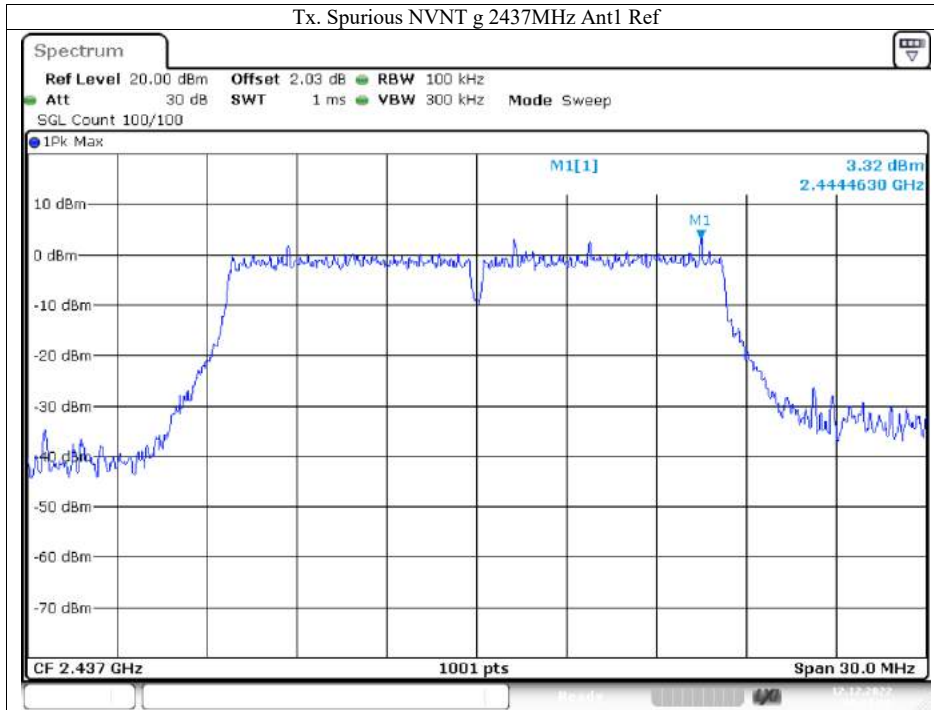

Date: 12.DEC.2022 10:32:21

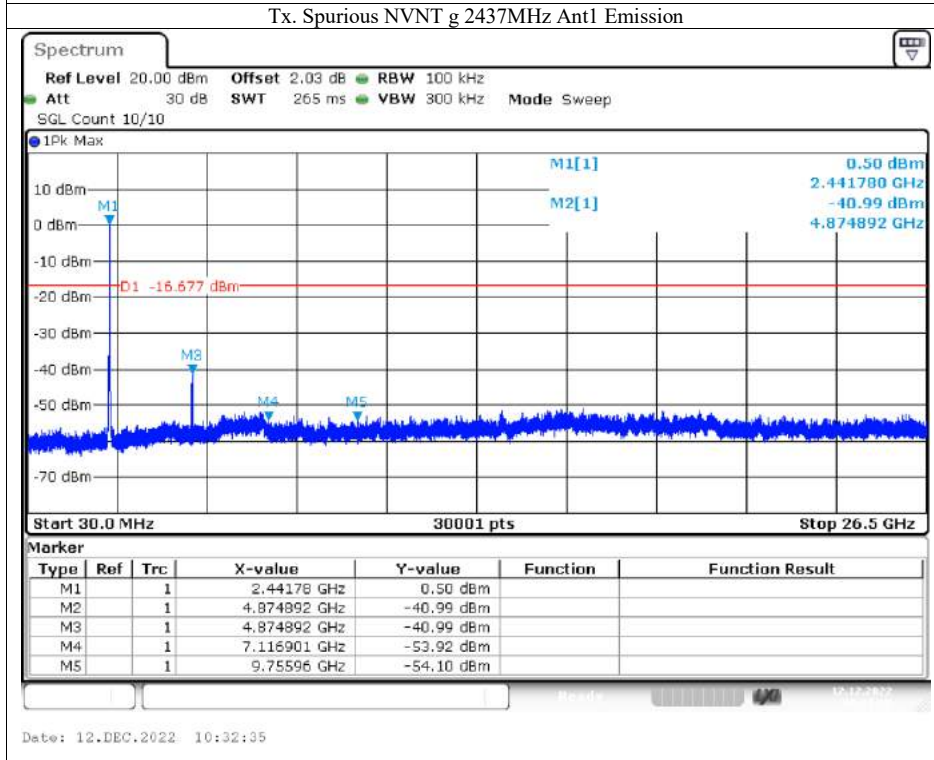

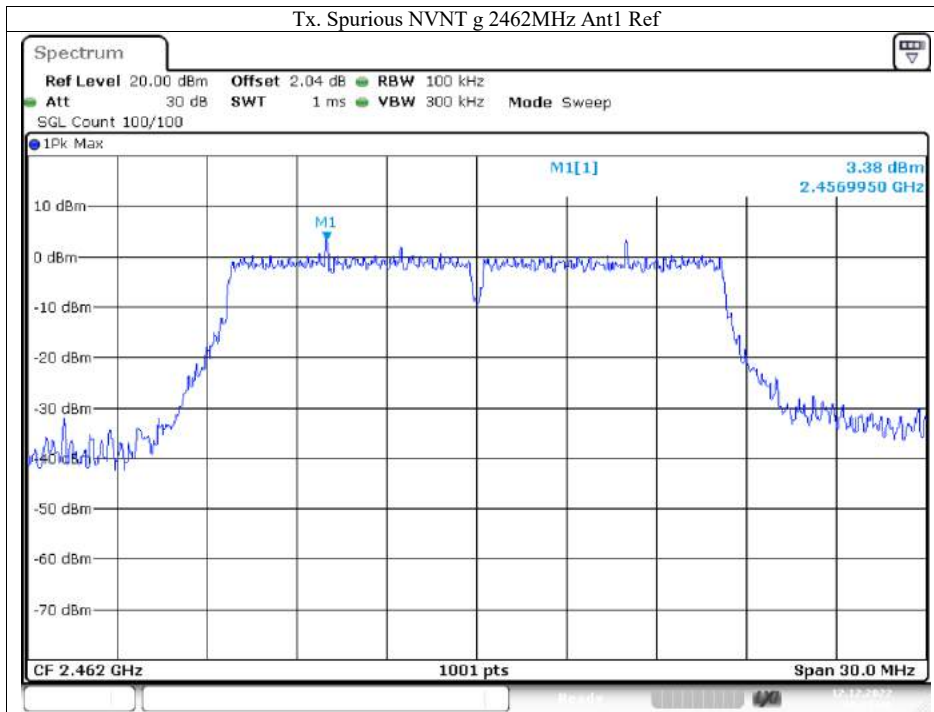

Date: 12.DEC.2022 10:35:46

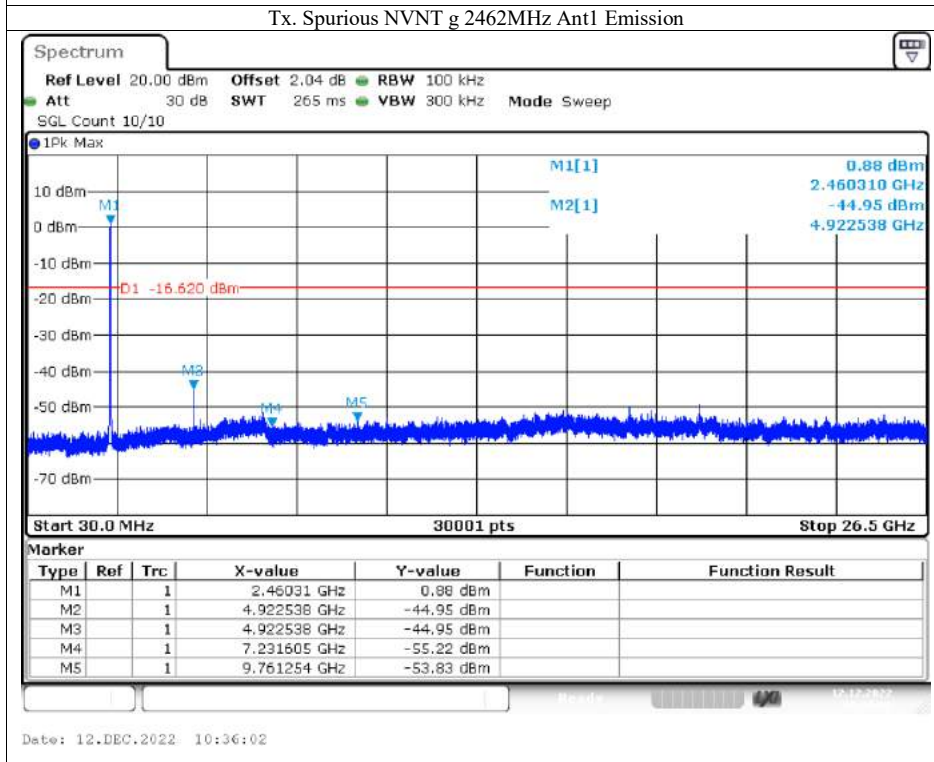

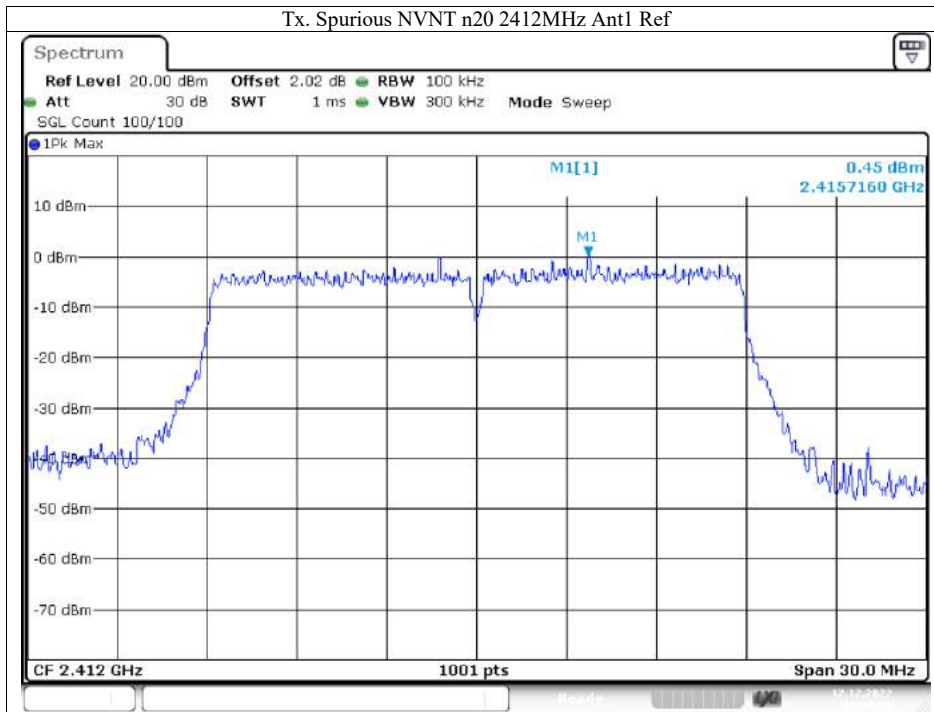

Date: 12.DEC.2022 10:40:55

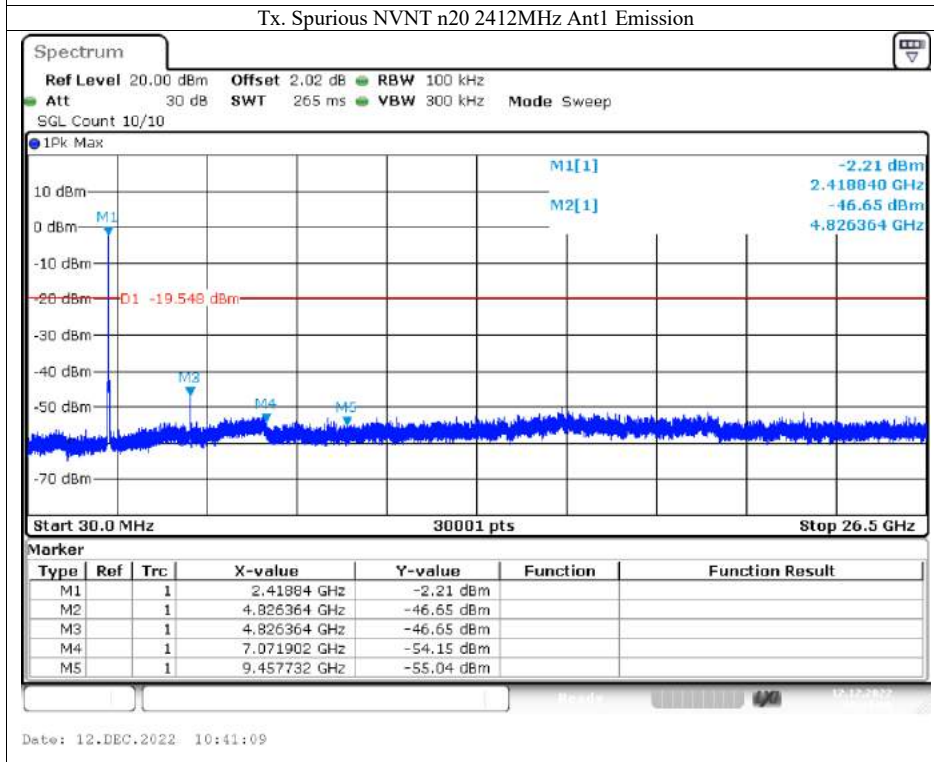

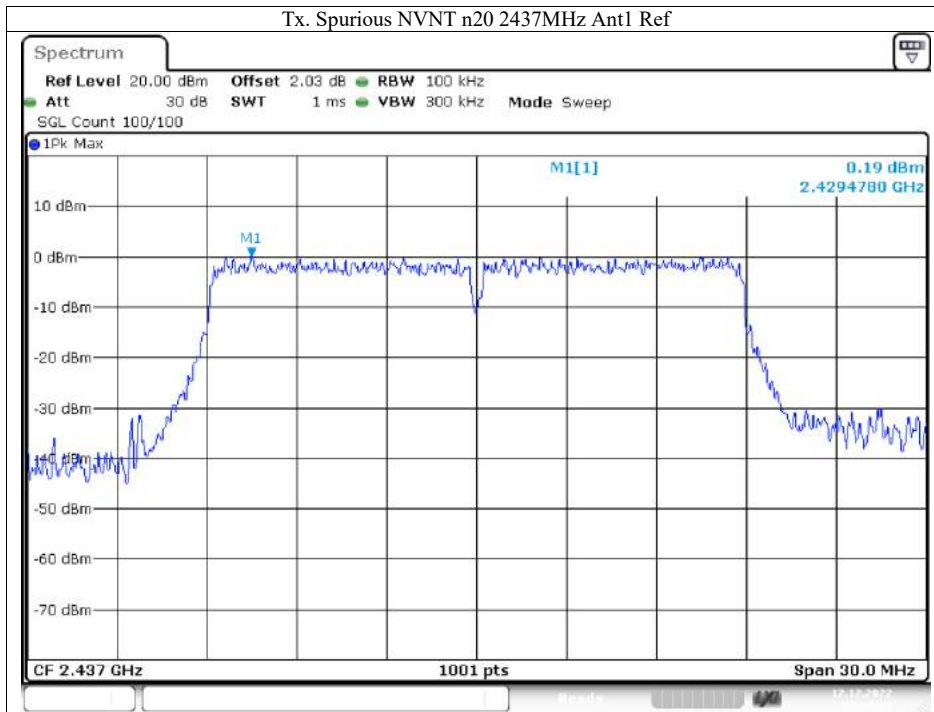

Date: 12.DEC.2022 10:44:10

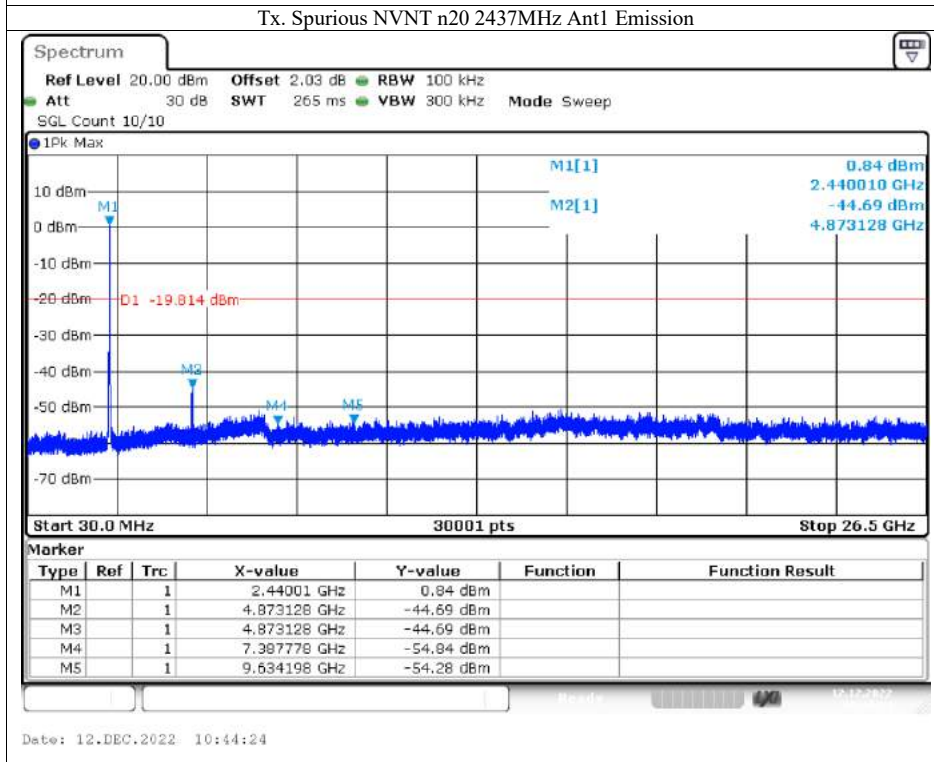

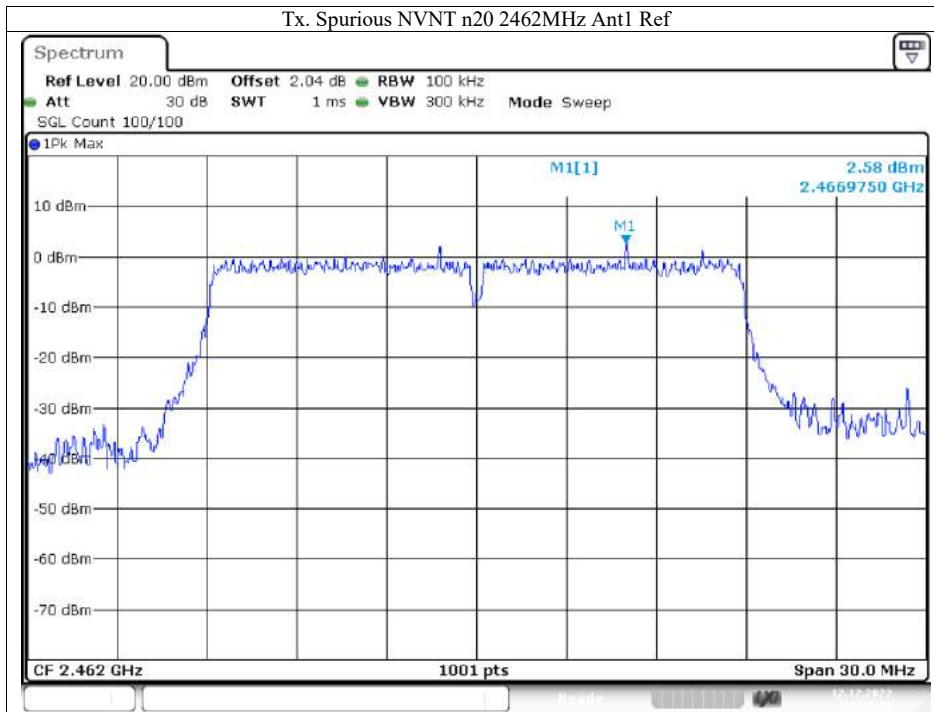

Date: 12.DEC.2022 10:48:16

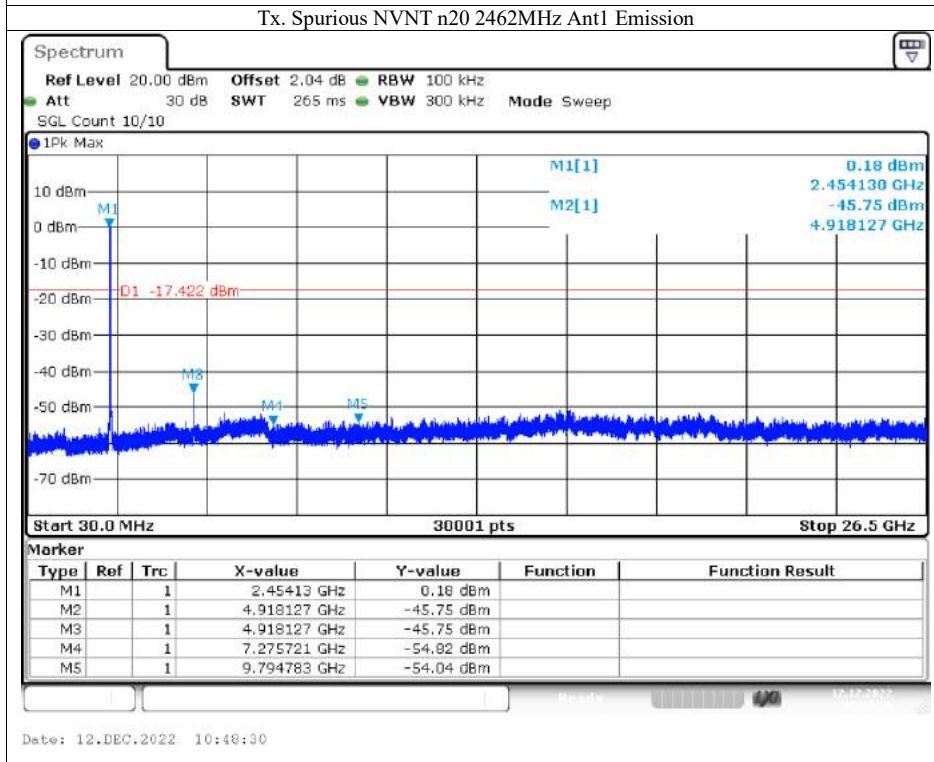

13. Antenna Application

13.1 Antenna Requirement

For intentional device, according to FCC 47 CFR Section 15.203, an intentional radiator shall be designed to ensure that no antenna other than that furnished by the responsible party shall be used with the device. And according to FCC 47 CFR Section 15.247 (b), if transmitting antennas of directional gain greater than 6dBi are used, the power shall be reduced by the amount in dB that the directional gain of the antenna exceeds 6dBi.

13.2 Result

The EUT'S antenna is an internal antenna. The antenna's gain is 2.82dBi and meets the requirement.

14. Photos of EUT

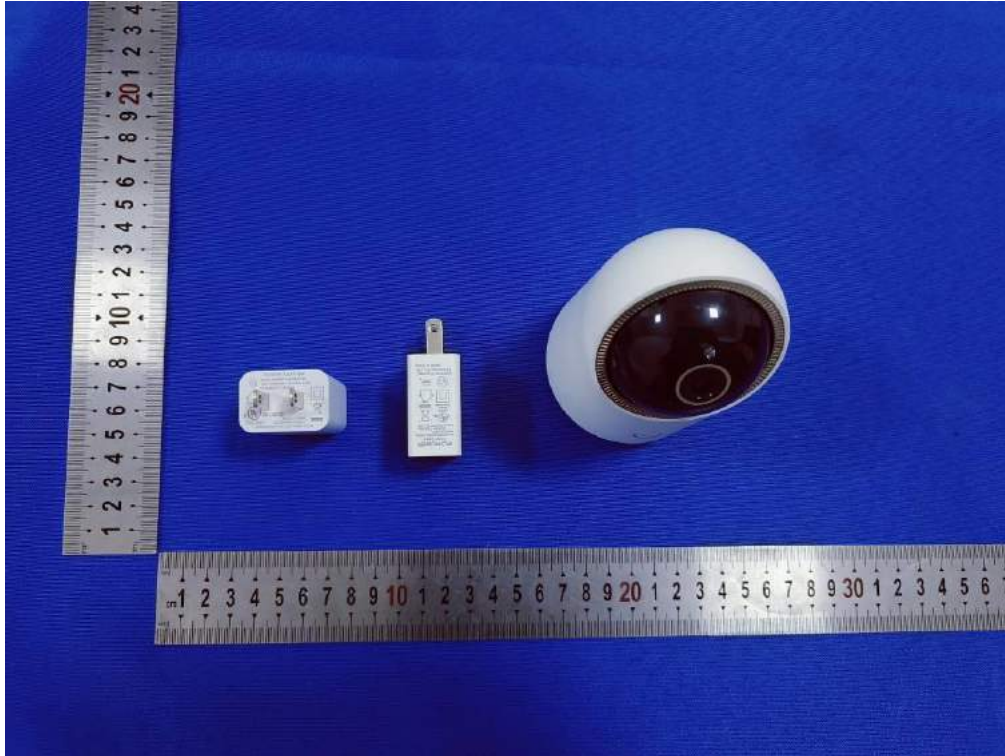

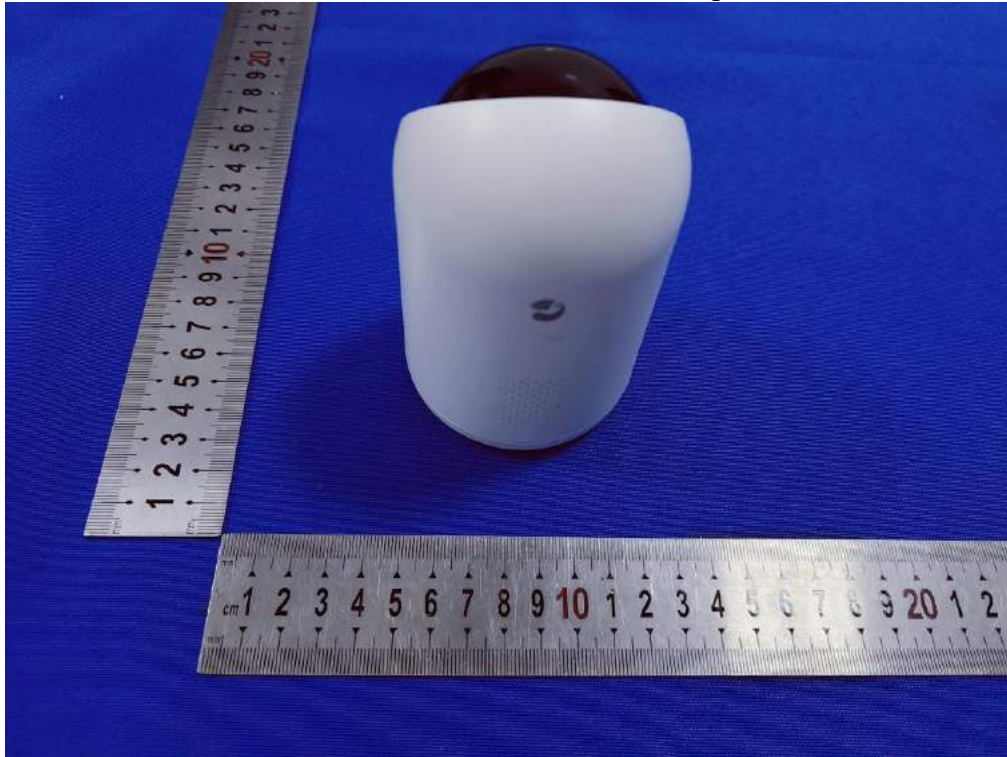

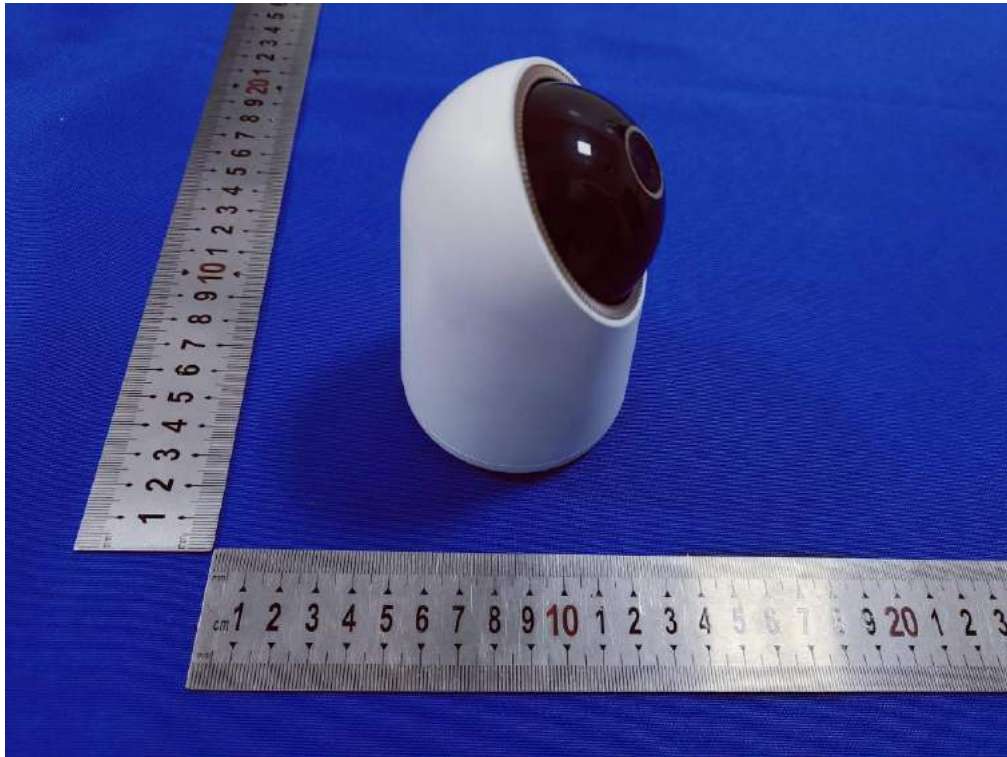
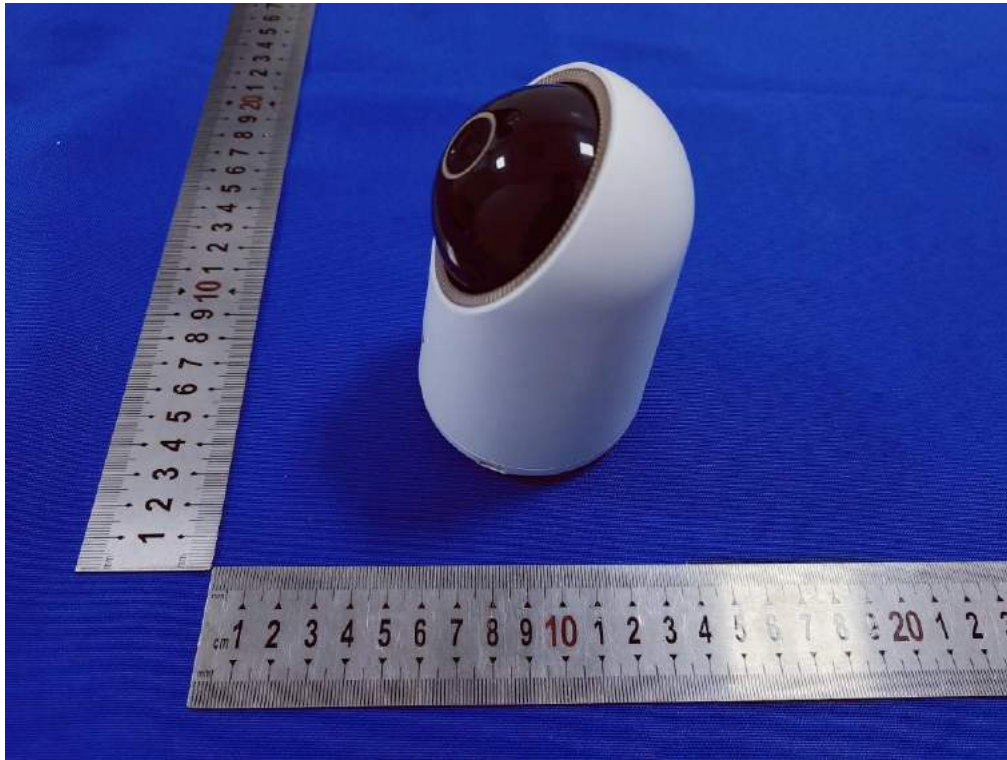



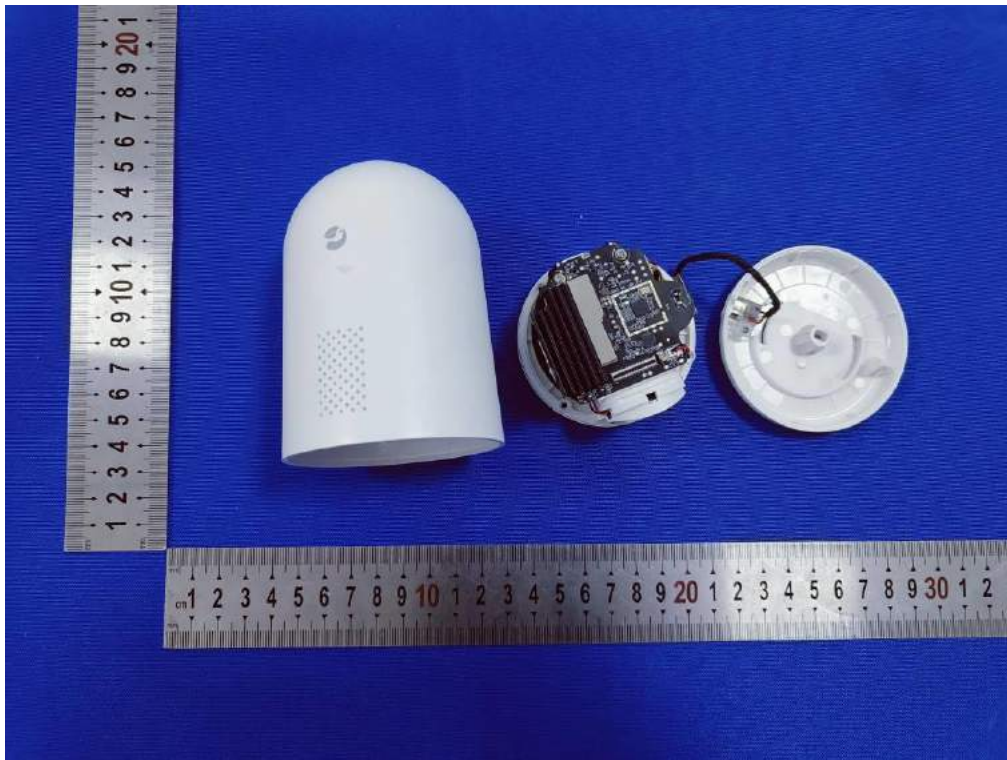
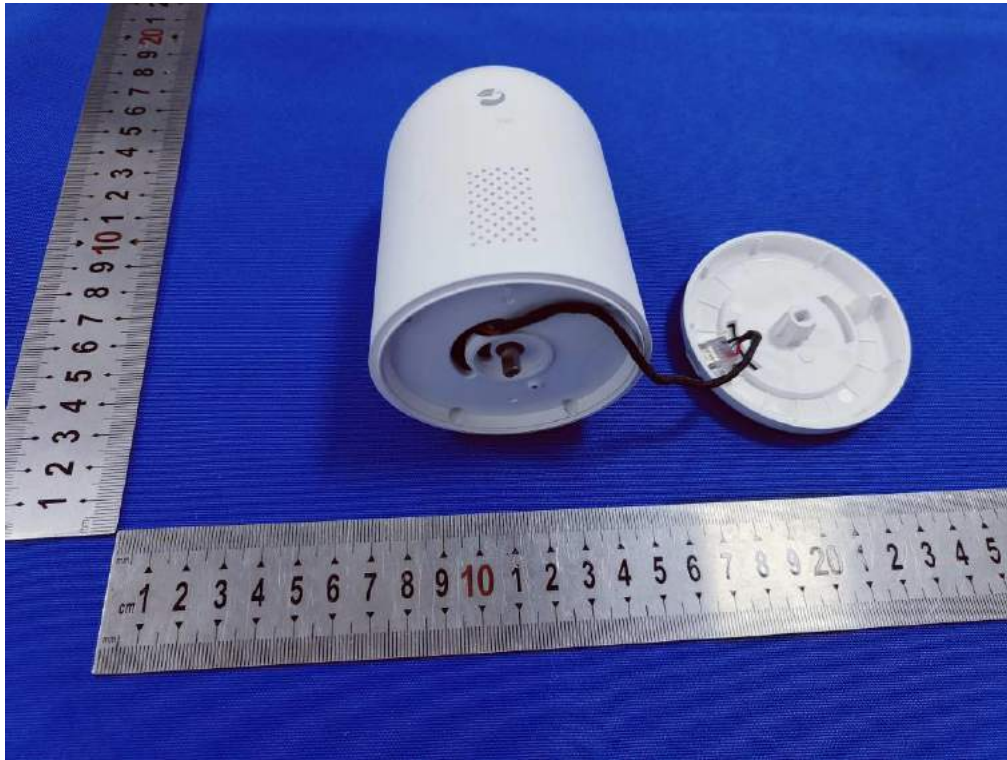

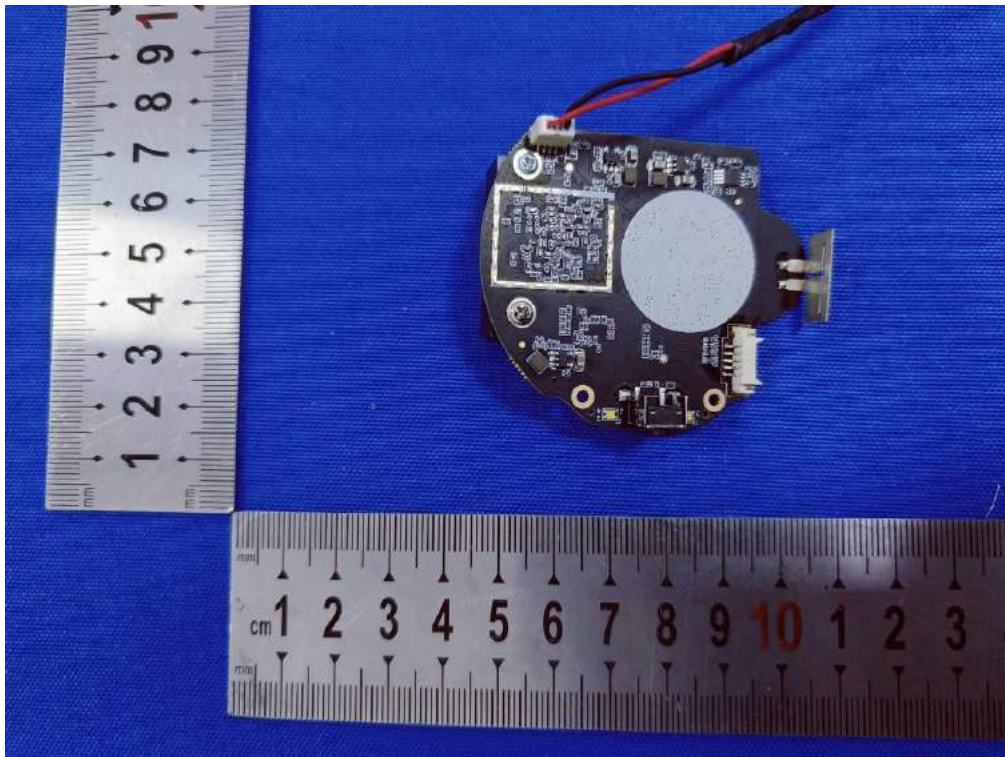
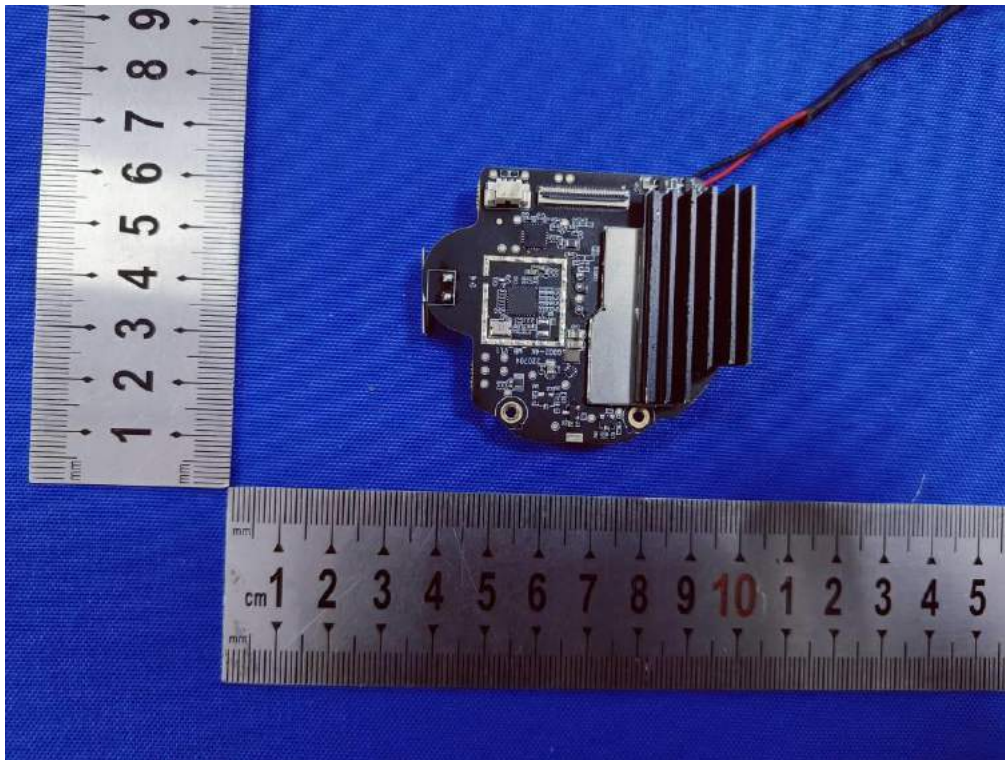

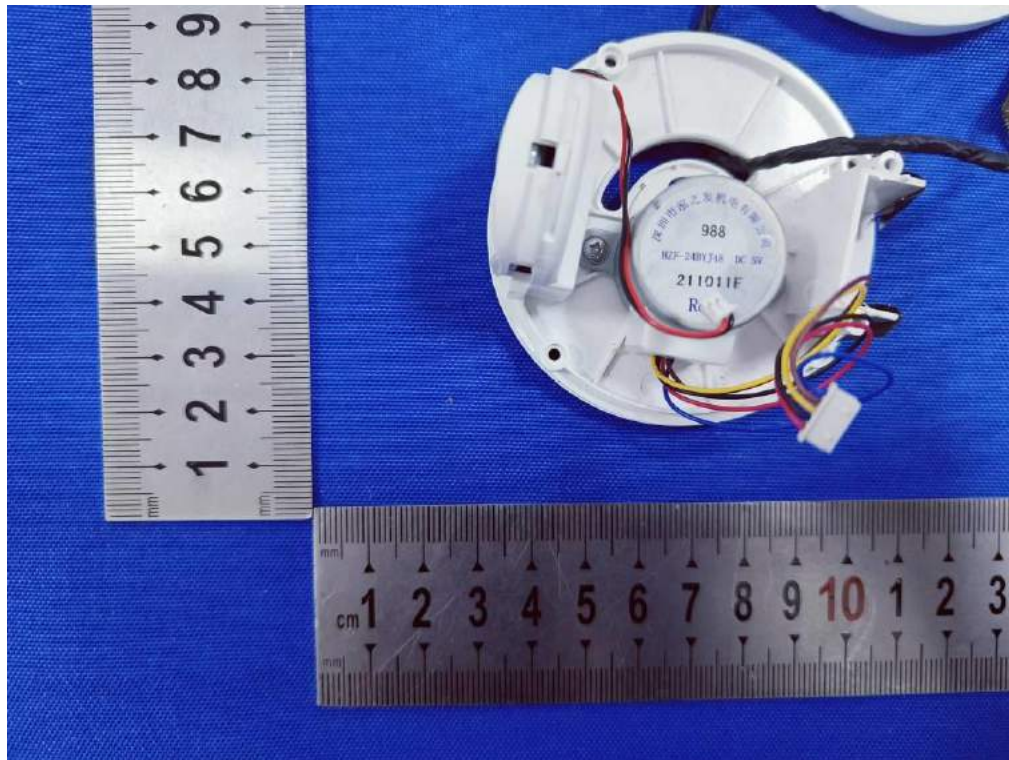
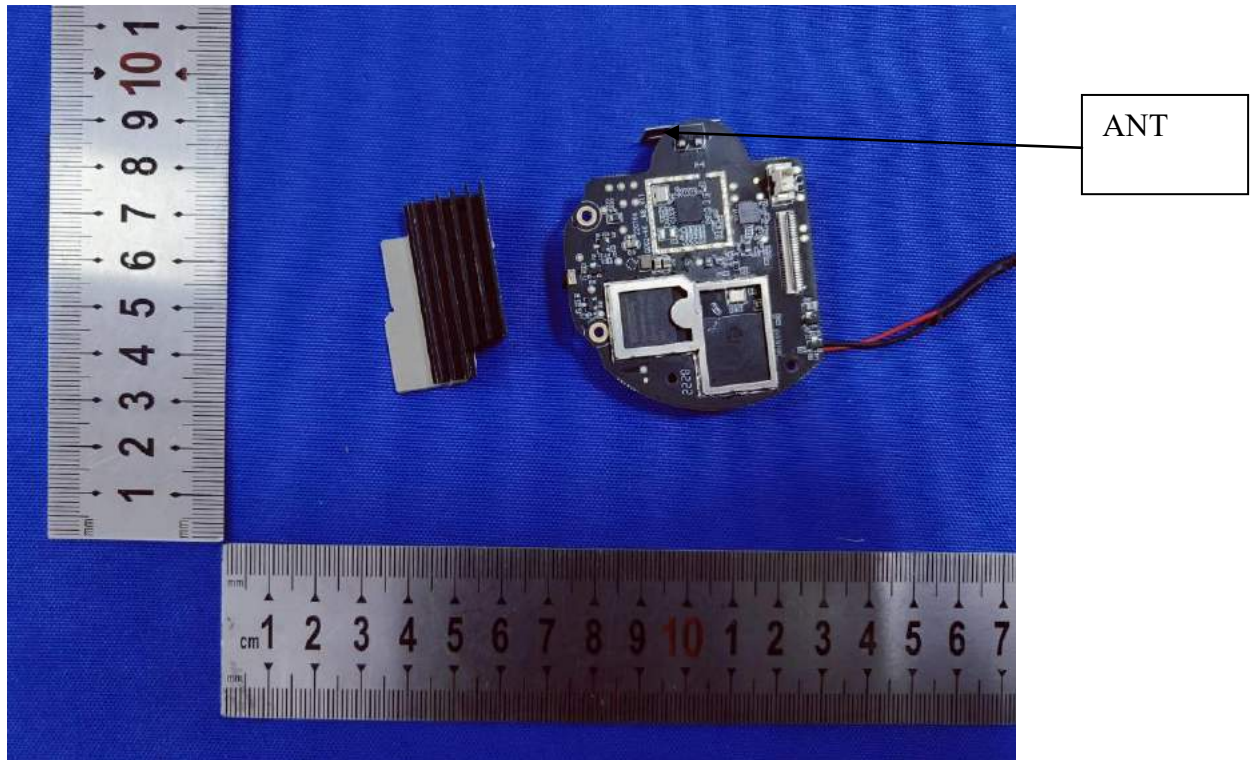

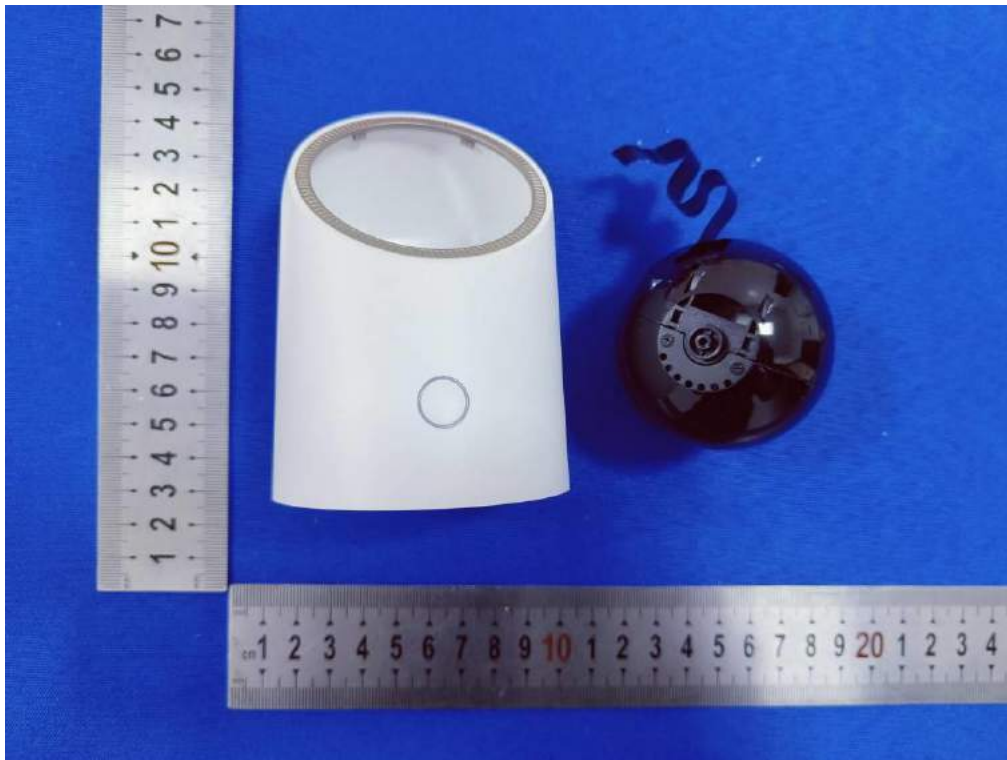
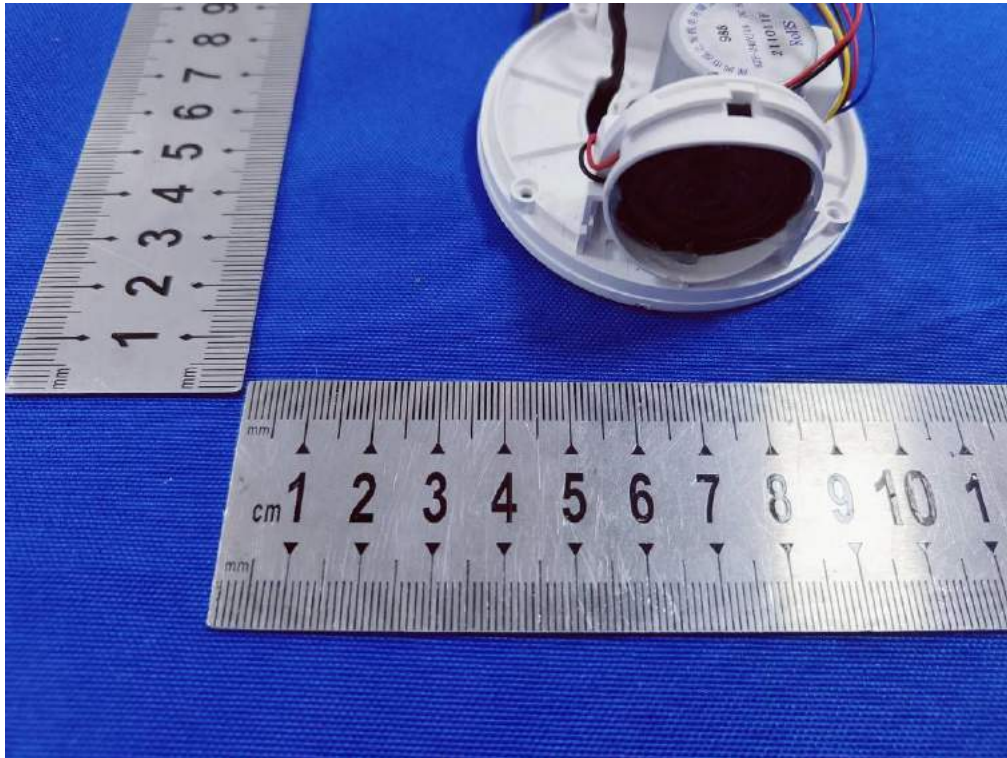

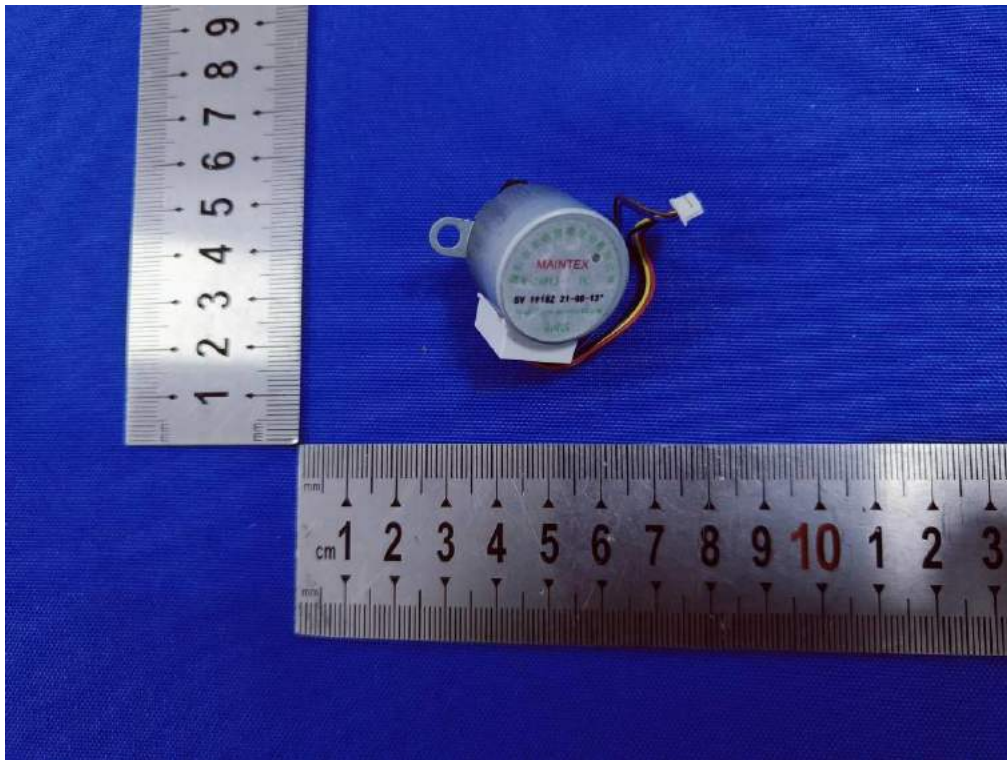

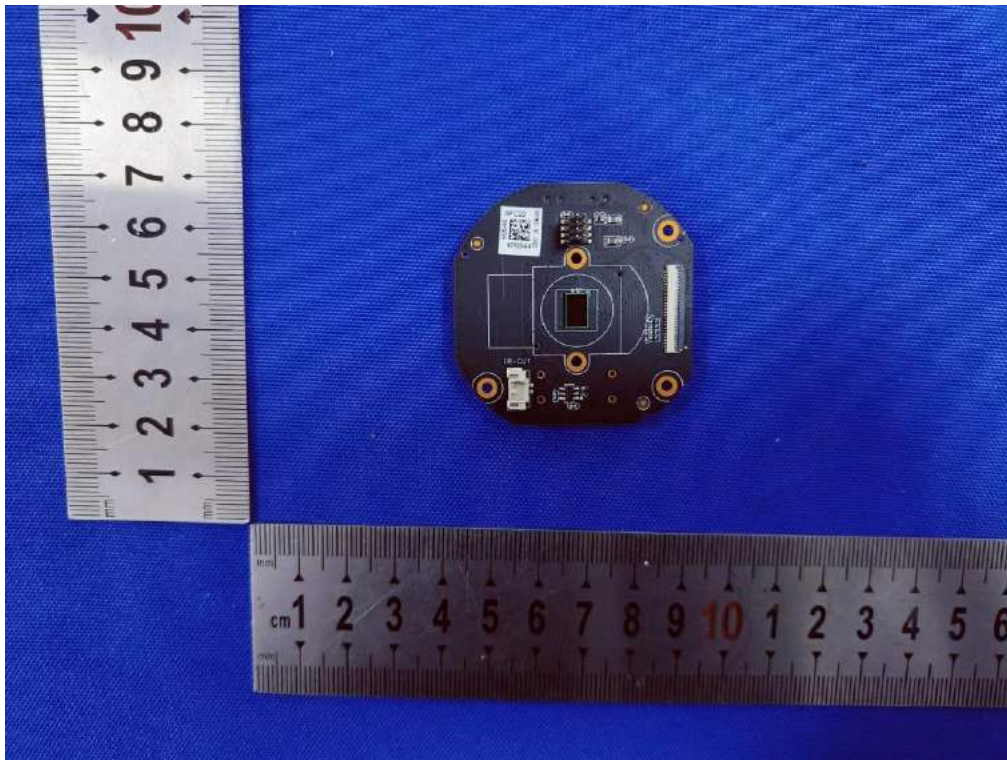
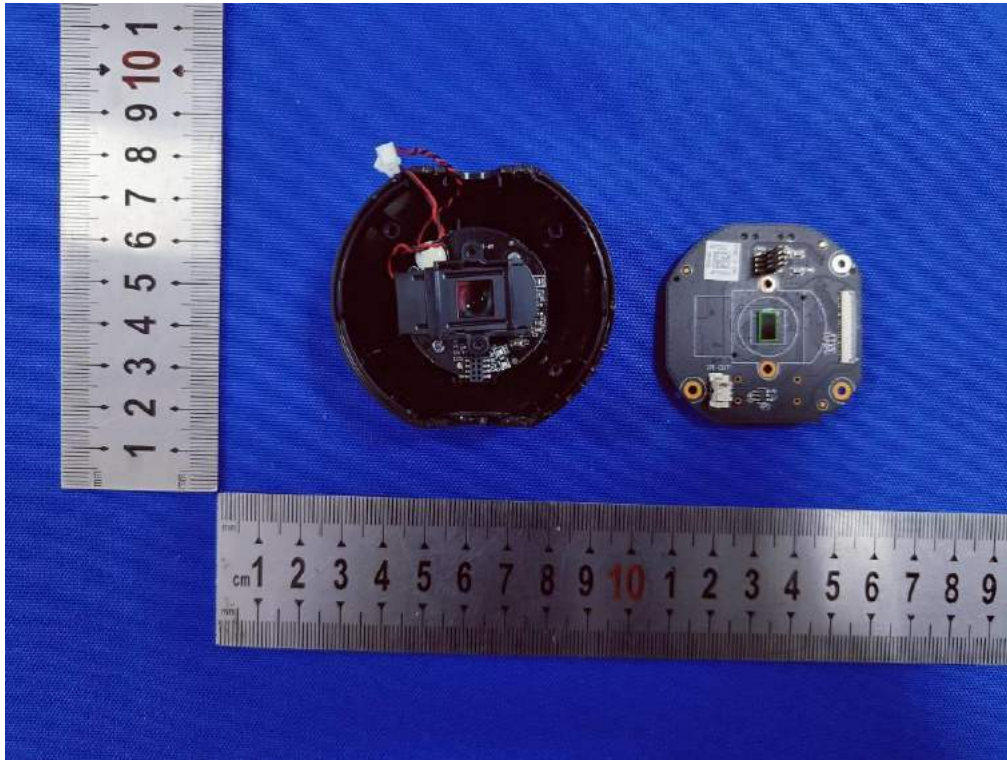

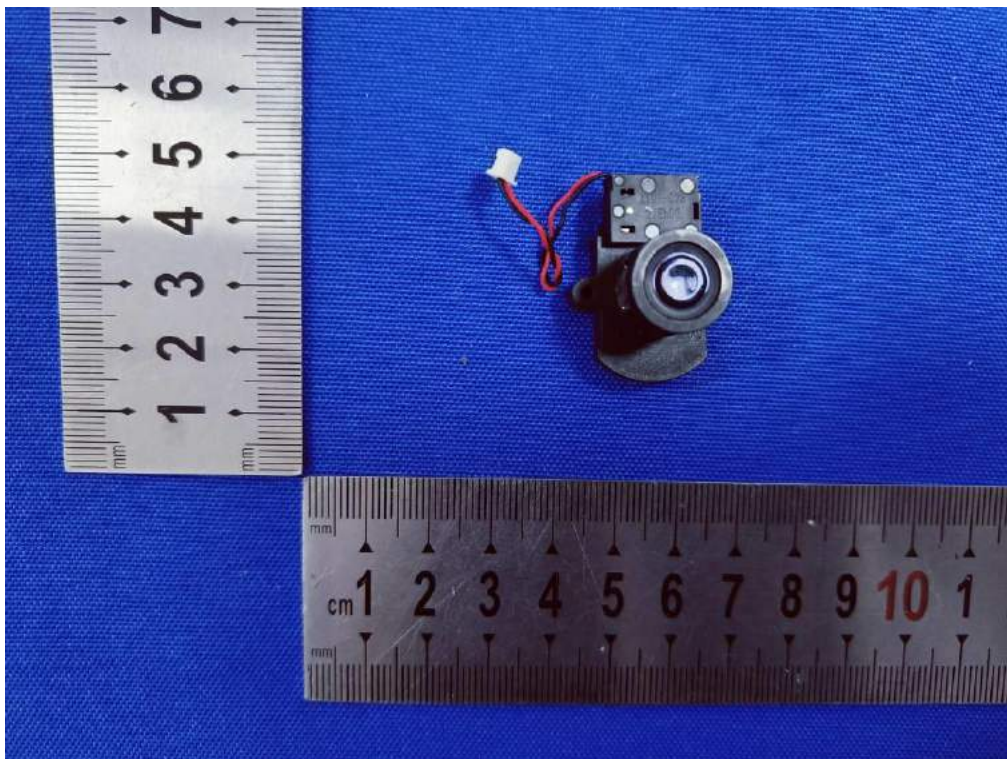
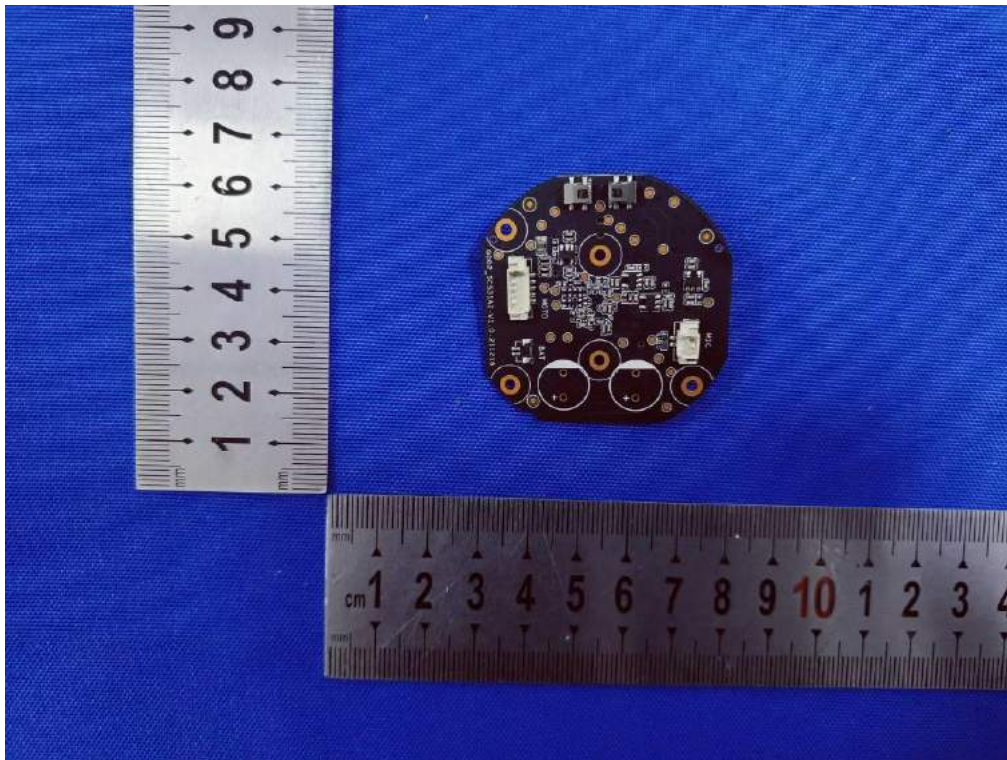

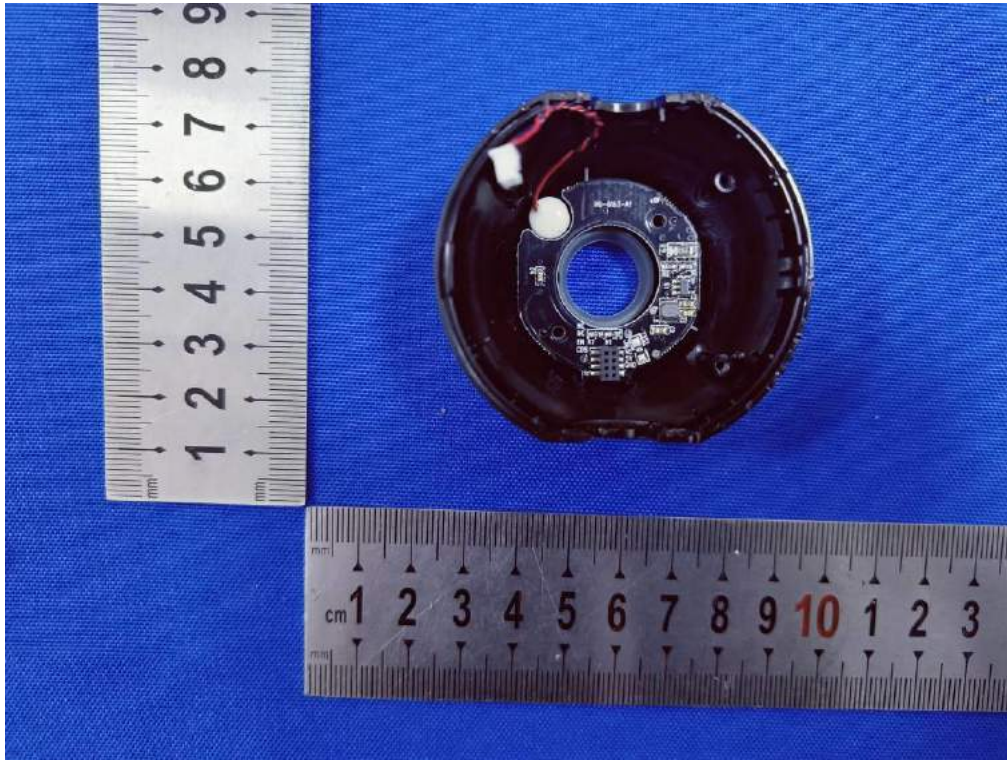



---The end of report---