

Above 1GHz

Test Mode:	Transmitting Mode
-------------------	--------------------------

Frequency (MHz)	Meter Reading (dBμV)	Antenna Factor (dB)	Cable loss (dB)	Preamp factor (dB)	Emission Level (dBμV/m)	Limits (dBμV/m)	Margin (dB)	Detector (PK/AV)	Polarity (H/V)
Low Channel:802.11b(Worst Case)-2412MHz									
2390	40.56	28.72	3.36	26.32	46.32	74	-27.68	peak	Vertical
4824	31.78	32.94	3.98	27.49	41.21	54	-12.79	Average	Vertical
4824	41.84	32.94	3.98	27.49	51.27	74	-22.73	peak	Vertical
7236	31.32	25.28	5.51	27.94	34.17	54	-19.83	Average	Vertical
7236	41.89	25.28	5.51	27.94	44.74	74	-29.26	peak	Vertical
2390	40.74	28.72	3.36	26.32	46.50	74	-27.50	peak	Horizontal
4824	30.79	32.94	3.98	27.49	40.22	54	-13.78	Average	Horizontal
4824	41.58	32.94	3.98	27.49	51.01	74	-22.99	peak	Horizontal
7236	30.74	25.28	5.51	27.94	33.59	54	-20.41	Average	Horizontal
7236	40.08	25.28	5.51	27.94	42.93	74	-31.07	peak	Horizontal
Middle Channel:802.11b(Worst Case)-2437MHz									
4874	31.75	32.11	4.04	27.53	40.37	54	-13.63	Average	Vertical
4874	41.58	32.11	4.04	27.53	50.20	74	-23.80	peak	Vertical
7311	30.83	24.33	5.58	27.96	32.78	54	-21.22	Average	Vertical
7311	41.76	24.33	5.58	27.96	43.71	74	-30.29	peak	Vertical
4874	31.28	32.11	4.04	27.53	39.90	54	-14.10	Average	Horizontal
4874	41.49	32.11	4.04	27.53	50.11	74	-23.89	peak	Horizontal
7311	31.48	24.33	5.58	27.96	33.43	54	-20.57	Average	Horizontal
7311	40.55	24.33	5.58	27.96	42.50	74	-31.50	peak	Horizontal
High Channel:802.11b(Worst Case)-2462MHz									
2483.5	40.74	28.79	3.48	26.34	46.67	74	-27.33	peak	Vertical
4924	31.79	31.32	4.12	27.58	39.65	54	-14.35	Average	Vertical
4924	41.64	31.32	4.12	27.58	49.50	74	-24.50	peak	Vertical
7386	31.64	24.38	5.68	27.99	33.71	54	-20.29	Average	Vertical
7386	41.58	24.38	5.68	27.99	43.65	74	-30.35	peak	Vertical
2483.5	39.78	28.79	3.48	26.34	45.71	74	-28.29	peak	Horizontal
4924	30.42	31.32	4.12	27.58	38.28	54	-15.72	Average	Horizontal
4924	41.55	31.32	4.12	27.58	49.41	74	-24.59	peak	Horizontal
7386	31.69	24.38	5.68	27.99	33.76	54	-20.24	Average	Horizontal
7386	41.48	24.38	5.68	27.99	43.55	74	-30.45	peak	Horizontal

NOTE:1.Absolute Level= ReadingLevel+antenna Factor+cable loss-preamp factor.

Note:

- 1, The testing has been conformed to 10*2462MHz=24,620MHz
- 2, All other emissions more than 30 dB below the limit
- 3, X-Axis, Y-Axis and Z-Axis were investigated. The results above show only the worst case.
- 4, The radiated spurious test above 18GHz is subcontracted to SIEMIC (Nanjing-China) Laboratories. and found 30dB below the limit at least.

Annex A. TEST INSTRUMENT

Instrument	Model	Serial #	Cal Date	Cal Due	In use
AC Line Conducted					
EMI test receiver	ESCS30	8471241027	09/15/2017	09/14/2018	<input checked="" type="checkbox"/>
Line Impedance	LI-125A	191106	09/23/2017	09/22/2018	<input checked="" type="checkbox"/>
Line Impedance	LI-125A	191107	09/23/2017	09/22/2018	<input checked="" type="checkbox"/>
ISN	ISN T800	34373	09/23/2017	09/22/2018	<input type="checkbox"/>
Transient Limiter	LIT-153	531118	08/30/2017	08/29/2018	<input type="checkbox"/>
RF conducted test					
Agilent ESA-E SERIES	E4407B	MY45108319	09/15/2017	09/14/2018	<input checked="" type="checkbox"/>
Power Splitter	1#	1#	08/30/2017	08/29/2018	<input checked="" type="checkbox"/>
DC Power Supply	E3640A	MY40004013	09/15/2017	09/14/2018	<input checked="" type="checkbox"/>
Radiated Emissions					
EMI test receiver	ESL6	100262	09/15/2017	09/14/2018	<input checked="" type="checkbox"/>
Positioning Controller	UC3000	MF780208282	11/17/2017	11/16/2018	<input checked="" type="checkbox"/>
OPT 010 AMPLIFIER (0.1-1300MHz)	8447E	2727A02430	08/30/2017	08/29/2018	<input checked="" type="checkbox"/>
Microwave Preamplifier (1 ~ 26.5GHz)	8449B	3008A02402	03/23/2017	03/22/2018	<input checked="" type="checkbox"/>
Horn Antenna	BBHA9170	3145226D1	09/27/2017	09/26/2018	<input checked="" type="checkbox"/>
Active Antenna (9kHz-30MHz)	AL-130	121031	10/12/2017	10/11/2018	<input checked="" type="checkbox"/>
Bilog Antenna (30MHz~6GHz)	JB6	A110712	09/19/2017	09/18/2018	<input checked="" type="checkbox"/>
Double Ridge Horn Antenna (1 ~18GHz)	AH-118	71283	09/22/2017	09/21/2018	<input checked="" type="checkbox"/>
Universal Radio Communication Tester	CMU200	121393	09/23/2017	09/22/2018	<input checked="" type="checkbox"/>

Annex B. EUT and Test Setup Photographs

Annex B.i. Photograph: EUT External Photo

Whole Package View



EUT - Front View

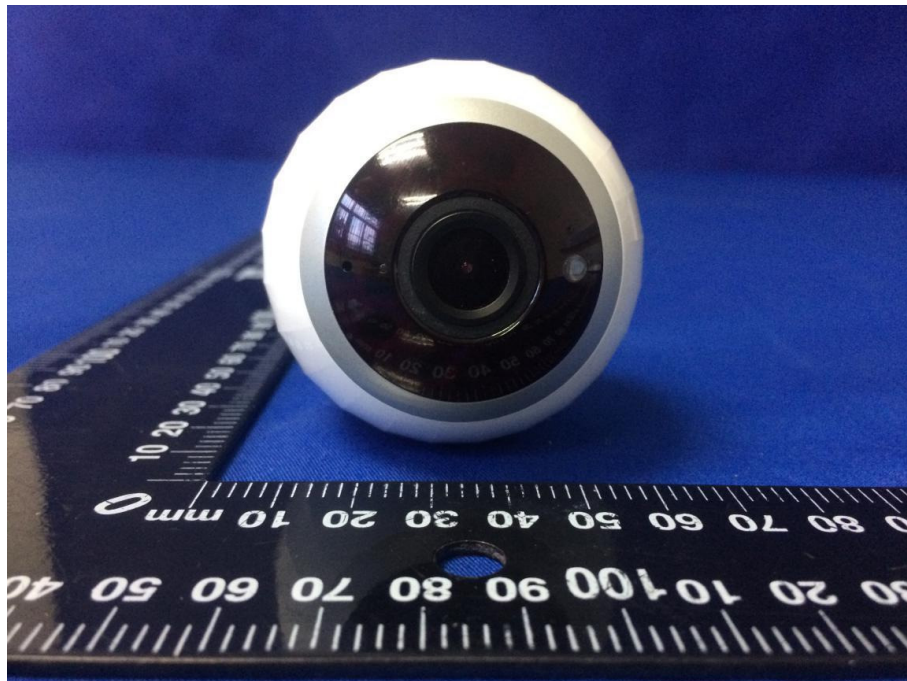

EUT - Rear View

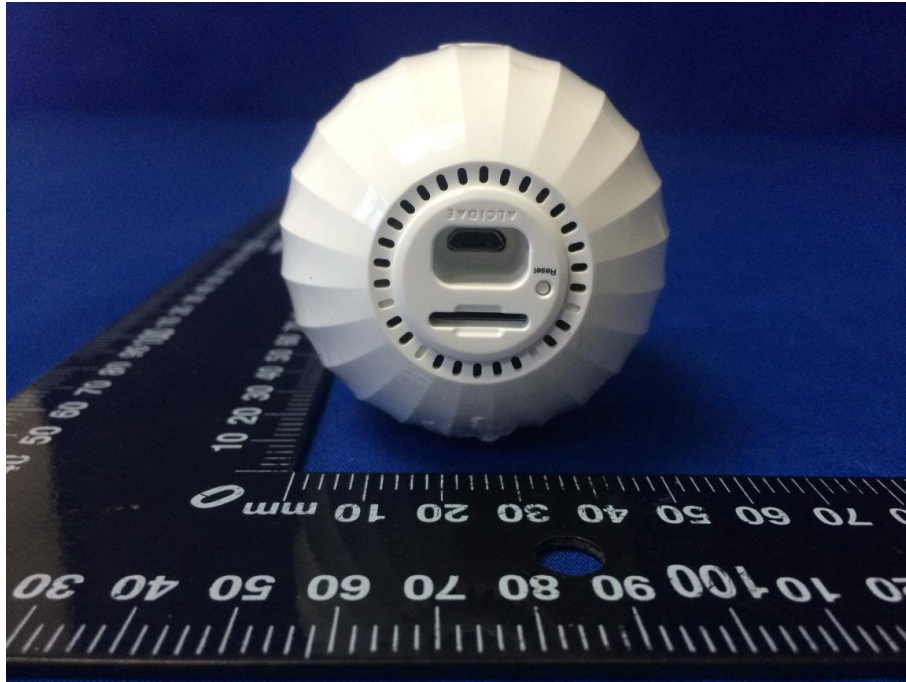

EUT - Top View



EUT - Bottom View



EUT - Left View

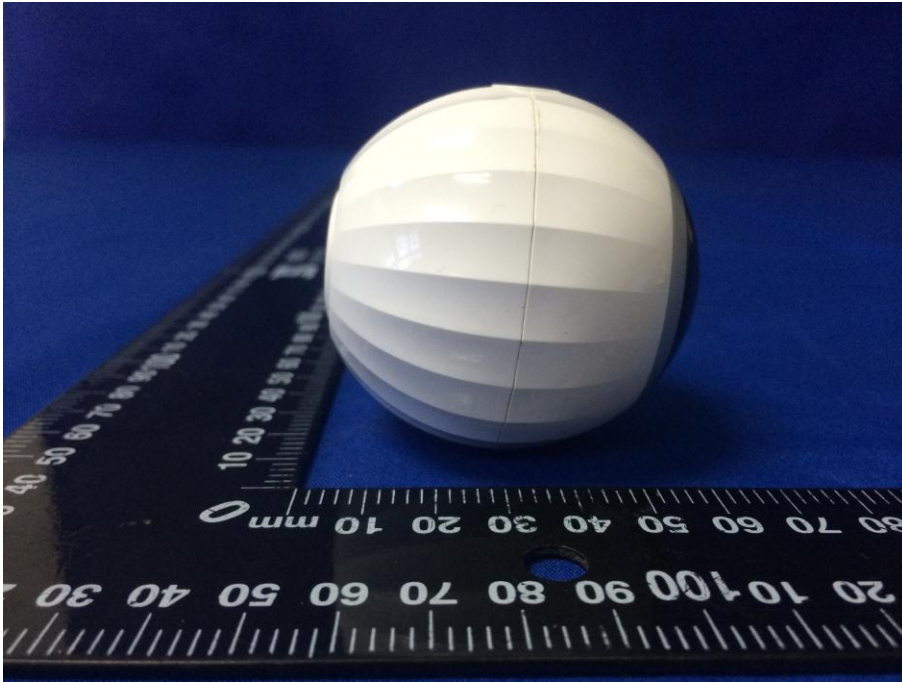

EUT - Right View

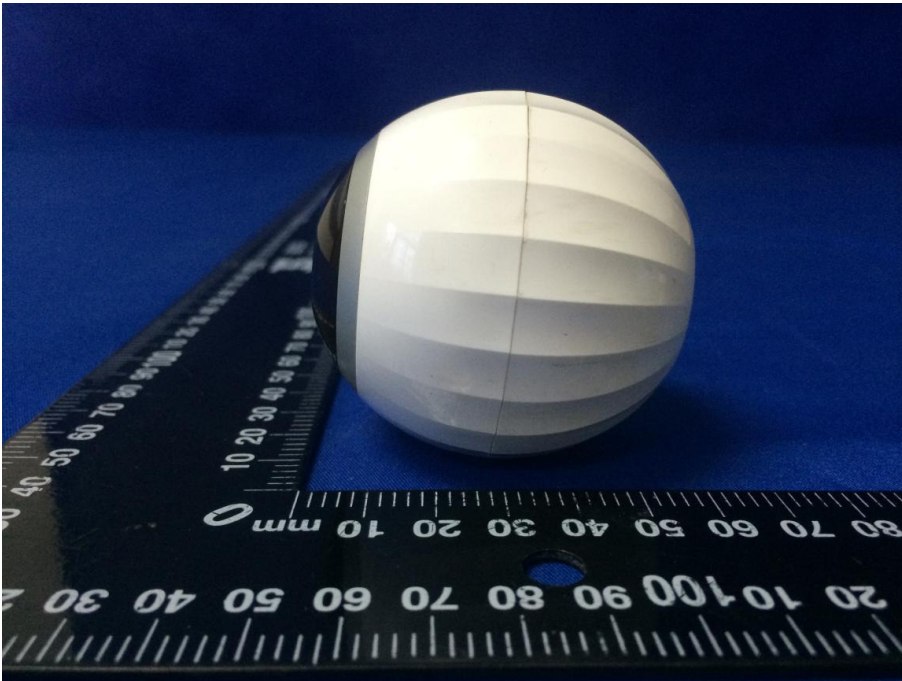

Base front View

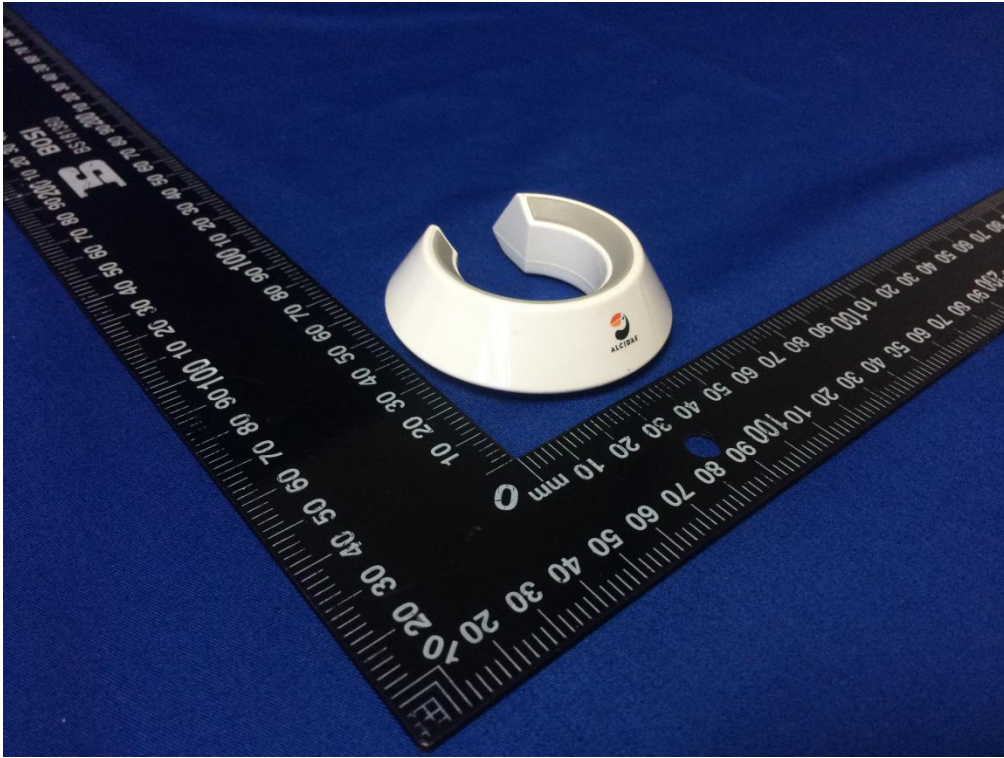

Base front View

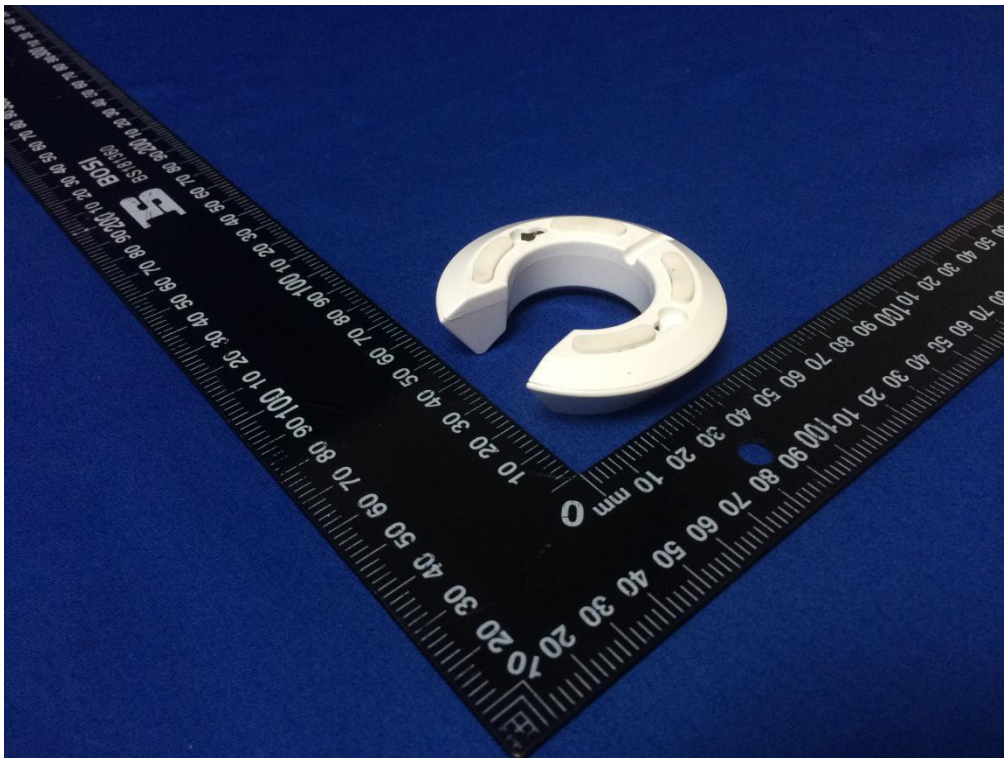

Test Report No.	17071408-FCC-R-V1
Page	48 of 64

Adapter label View



Annex B.ii. Photograph: EUT Internal Photo

Cover Off - Top View 1

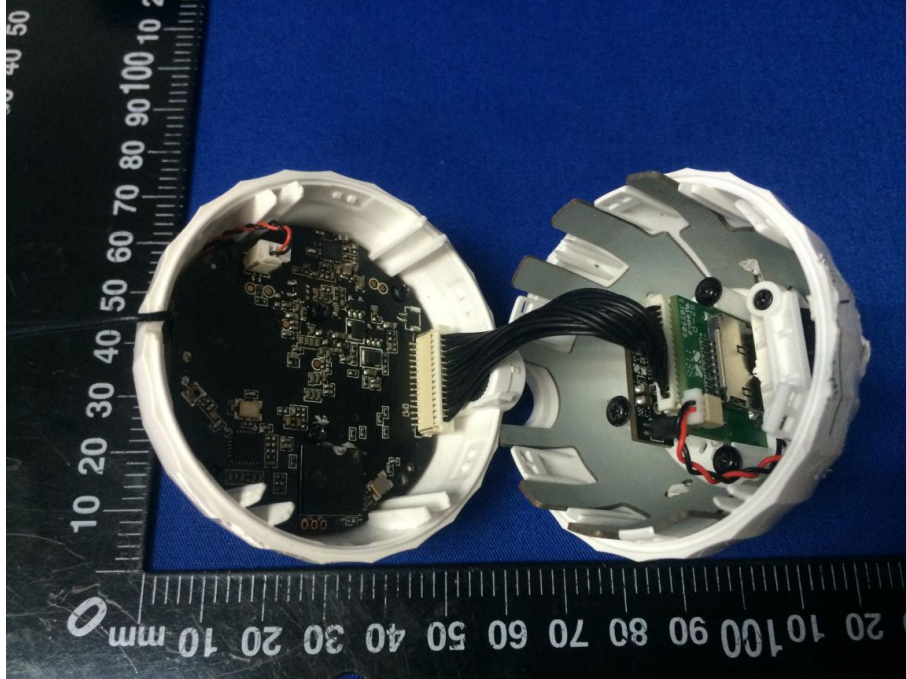

Cover Off - Top View 2

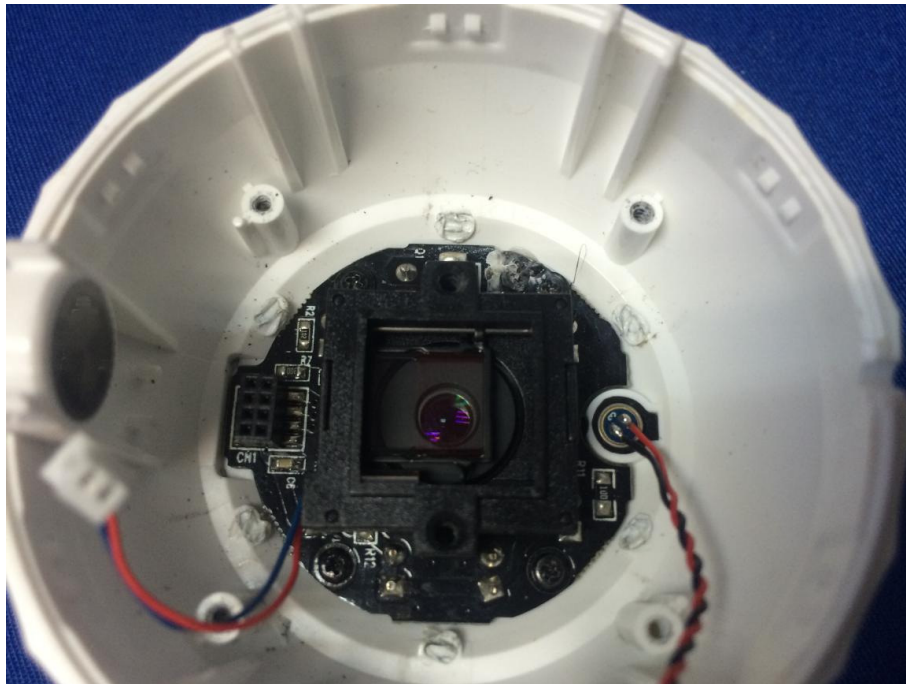

Mainboard - Front View

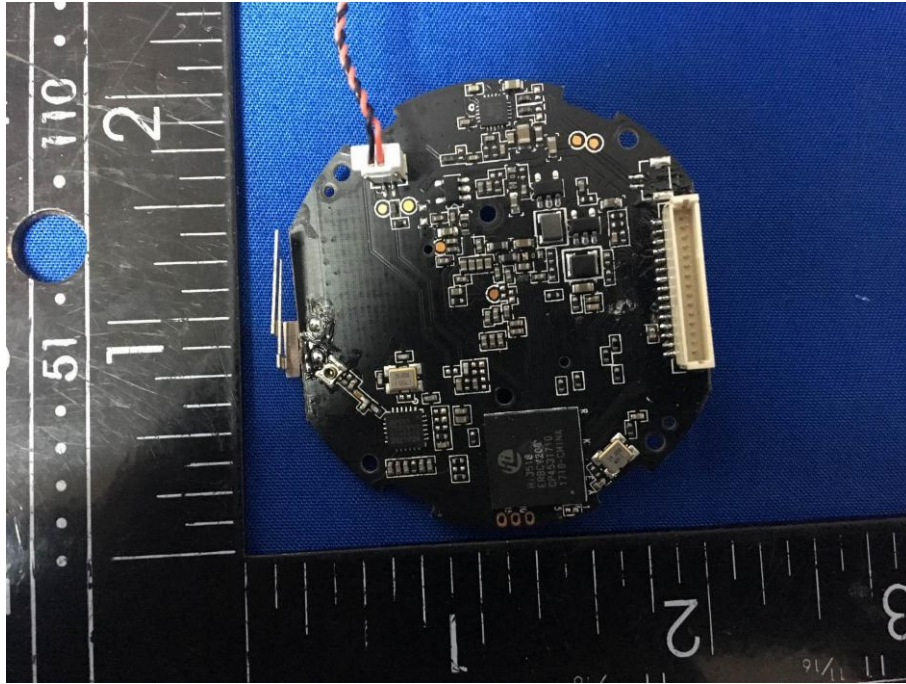

Mainboard - Rear View

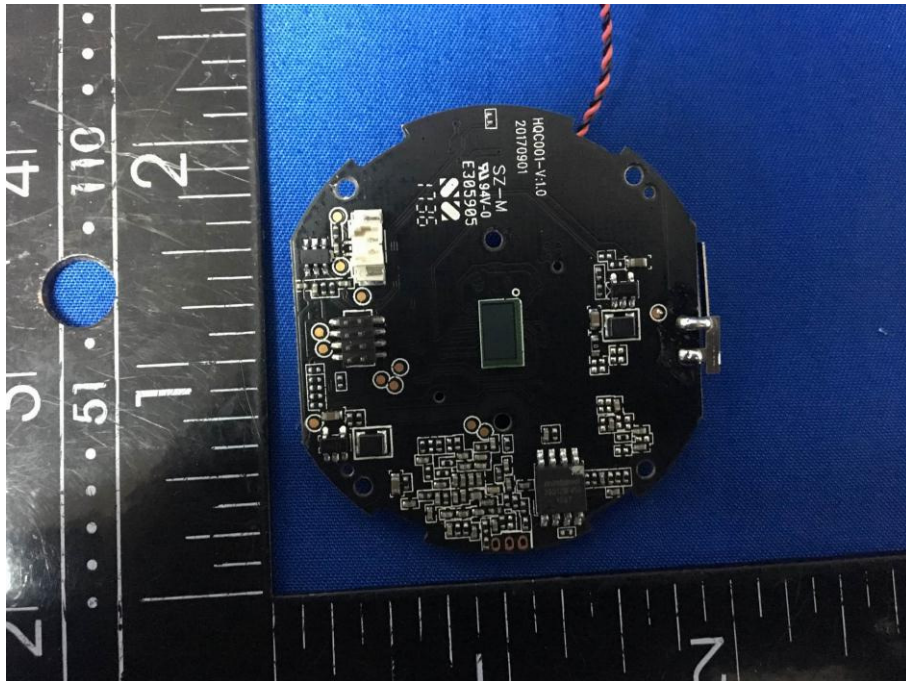

USB board – Front View

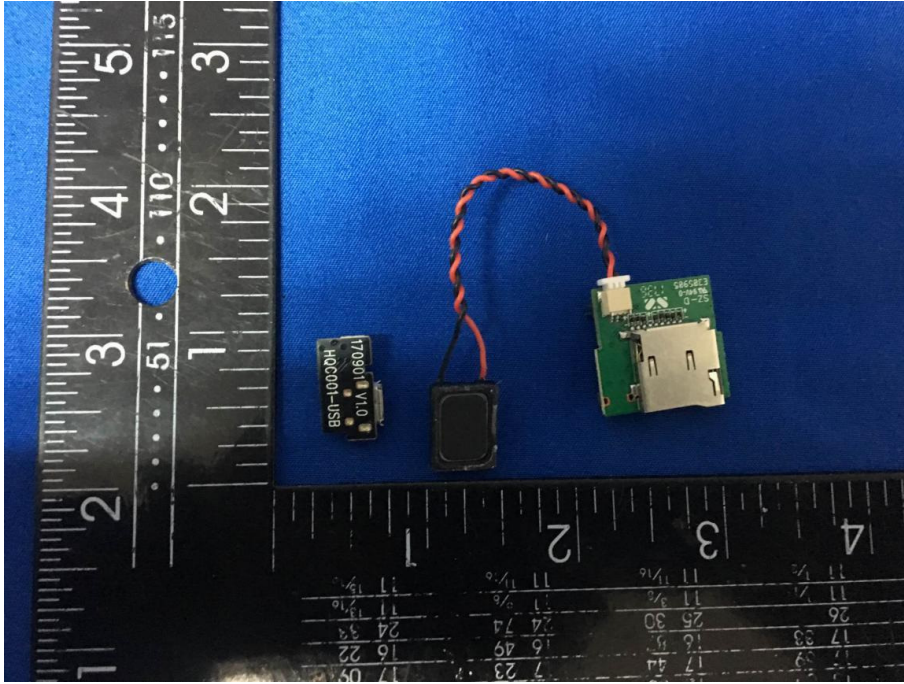

USB board – Rear View

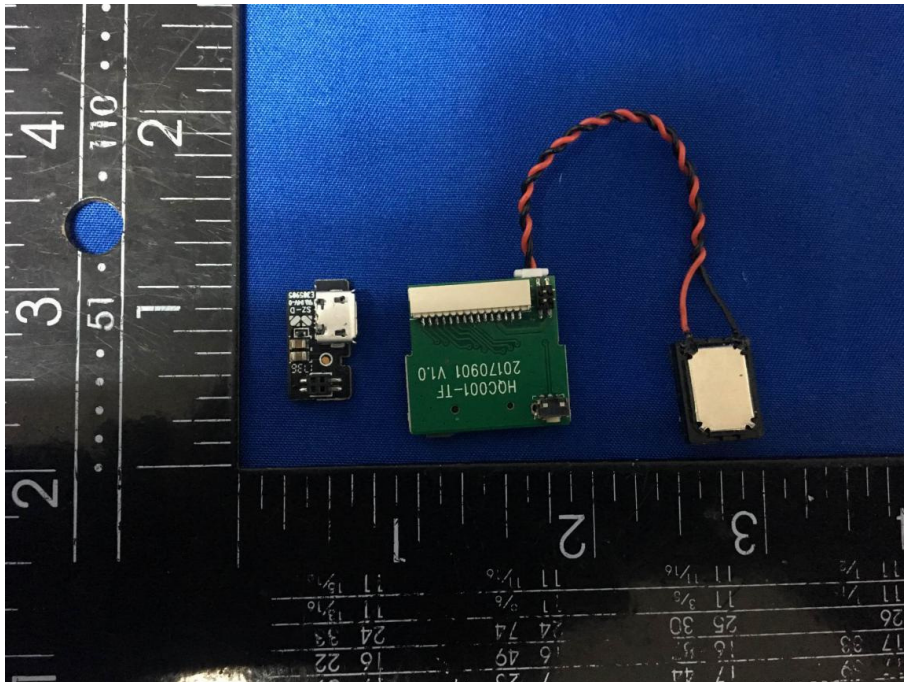

LED – Front View



LCD – Rear View

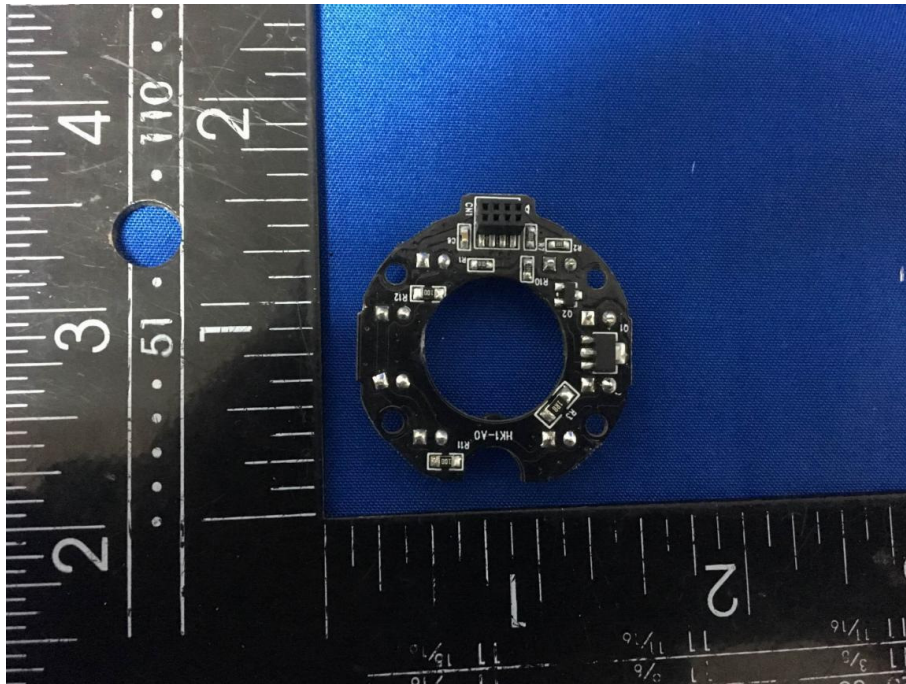

USB board – Front View

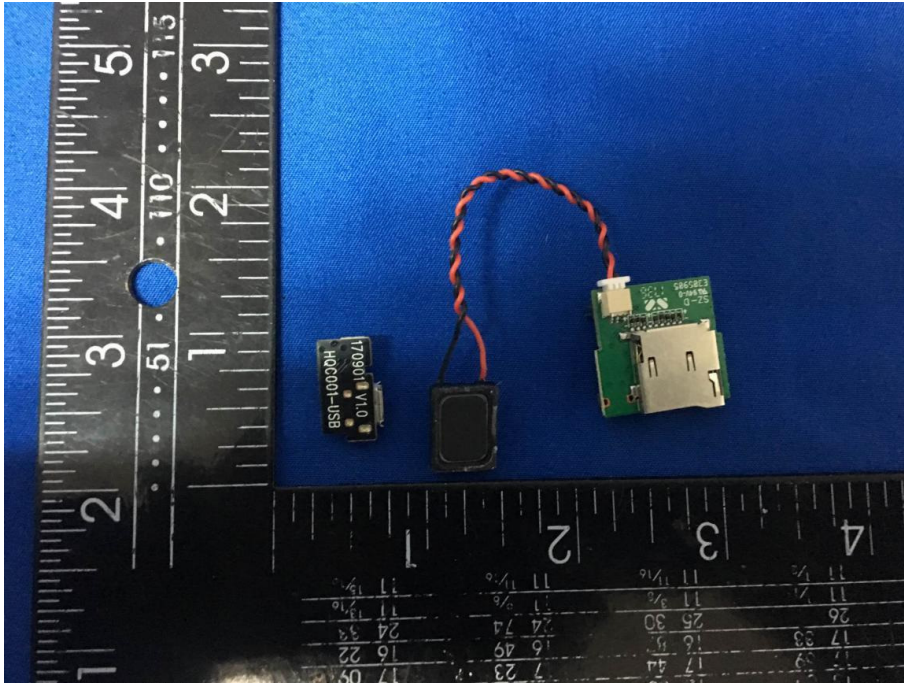

USB board – Rear View

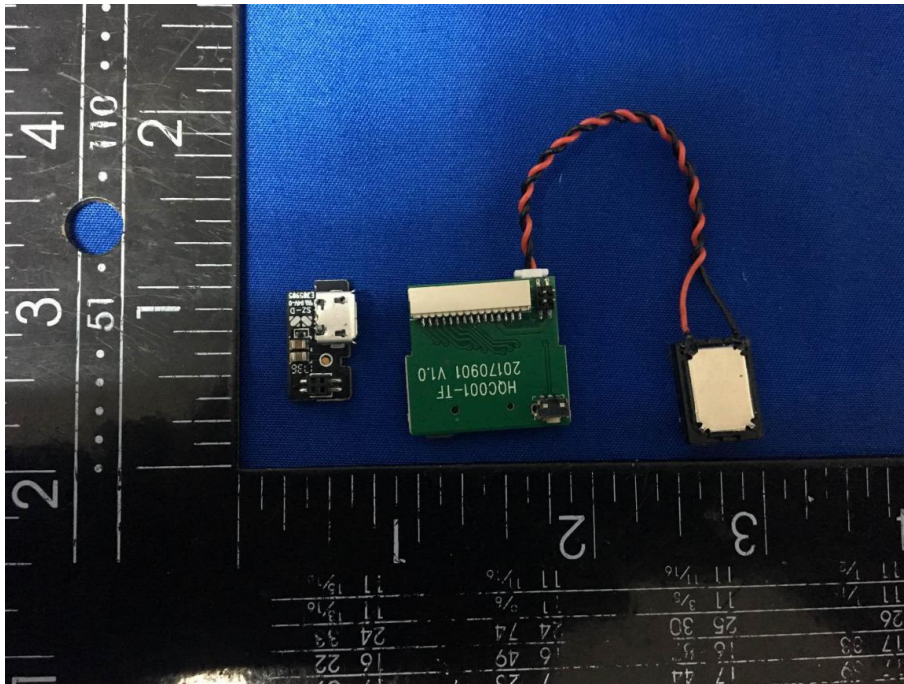

LED – Front View

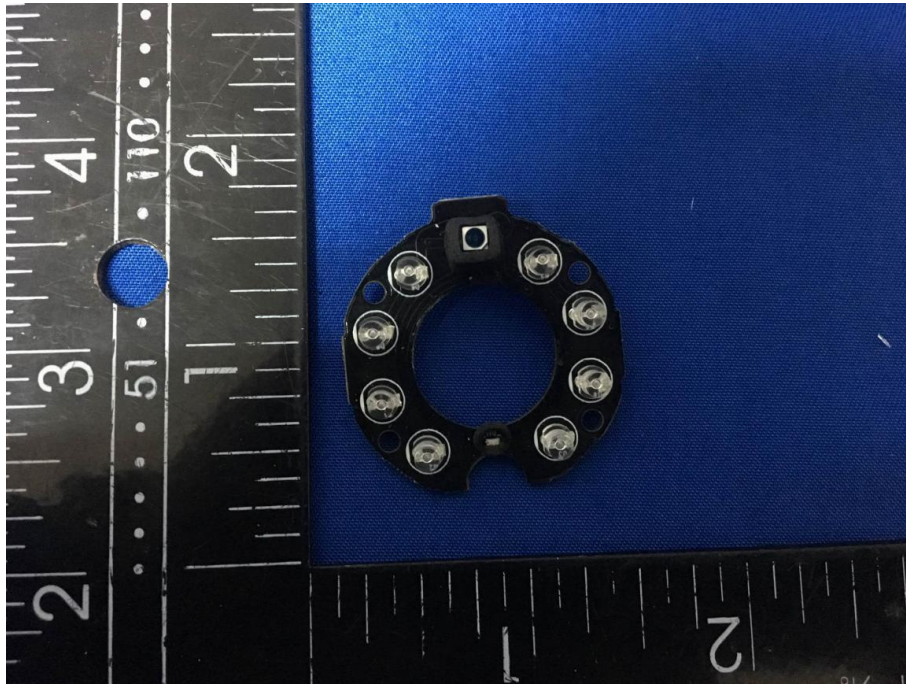

LCD – Rear View

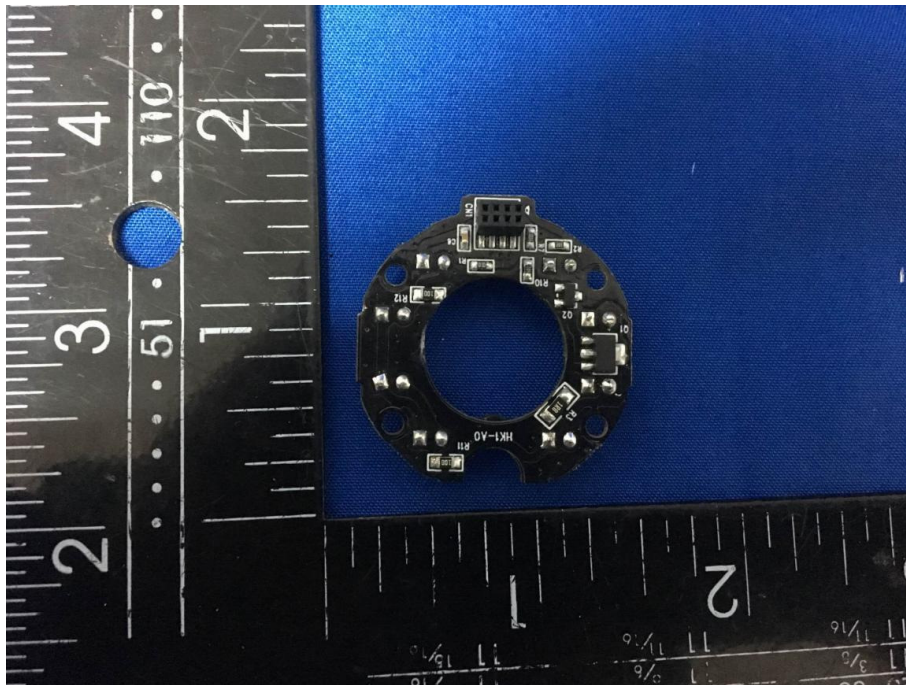

USB board – Front View

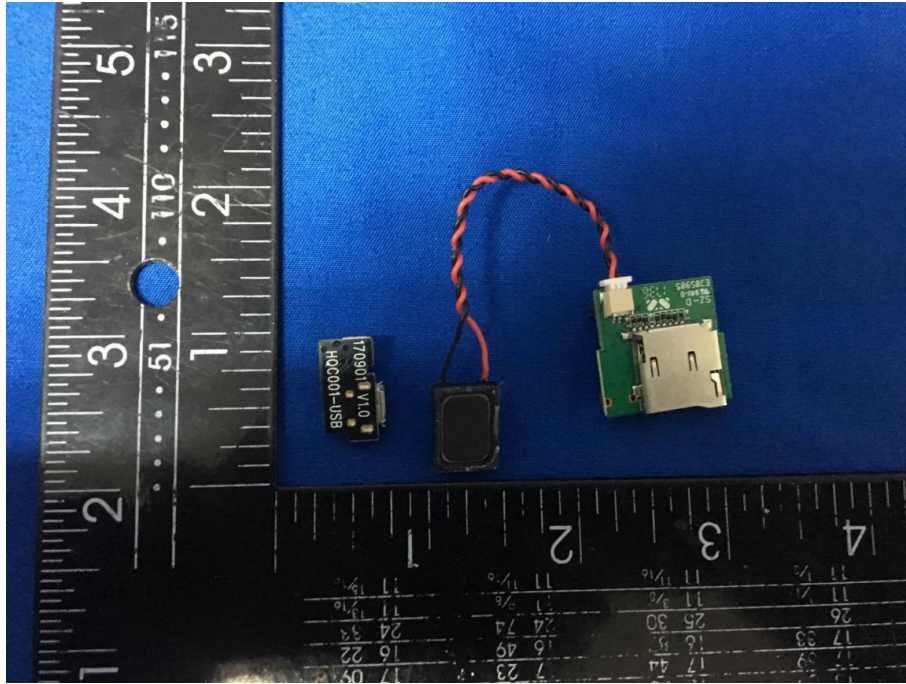

USB board – Rear View

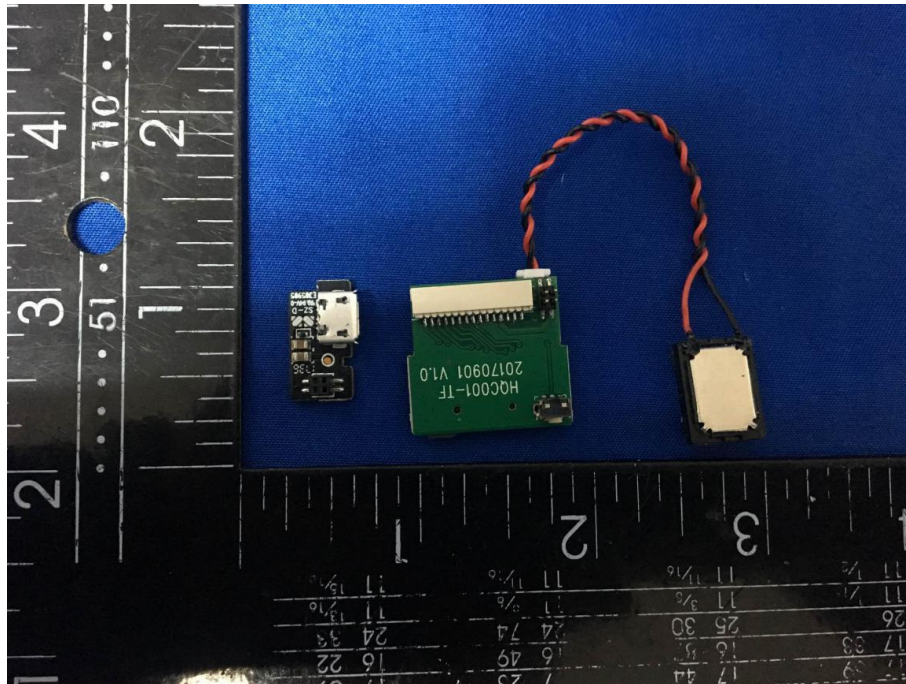

Camera – Front View

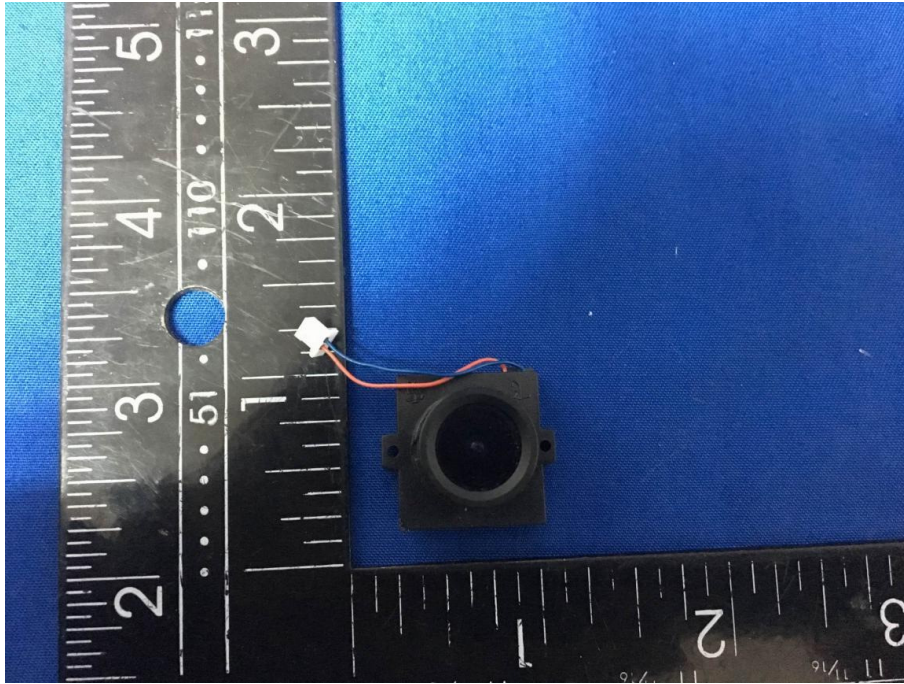

Camera– Rear View

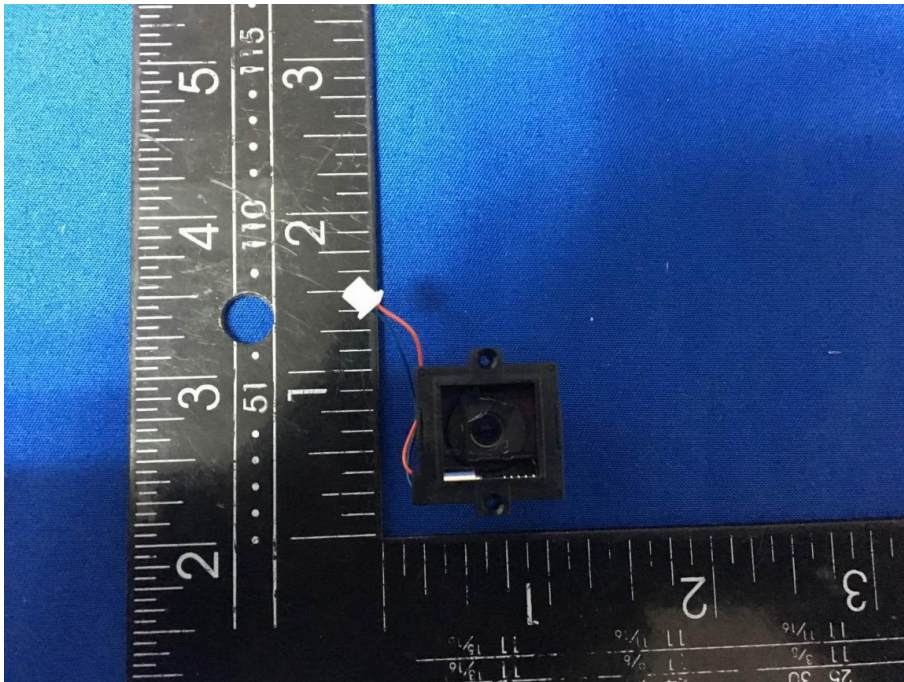

Antenna View

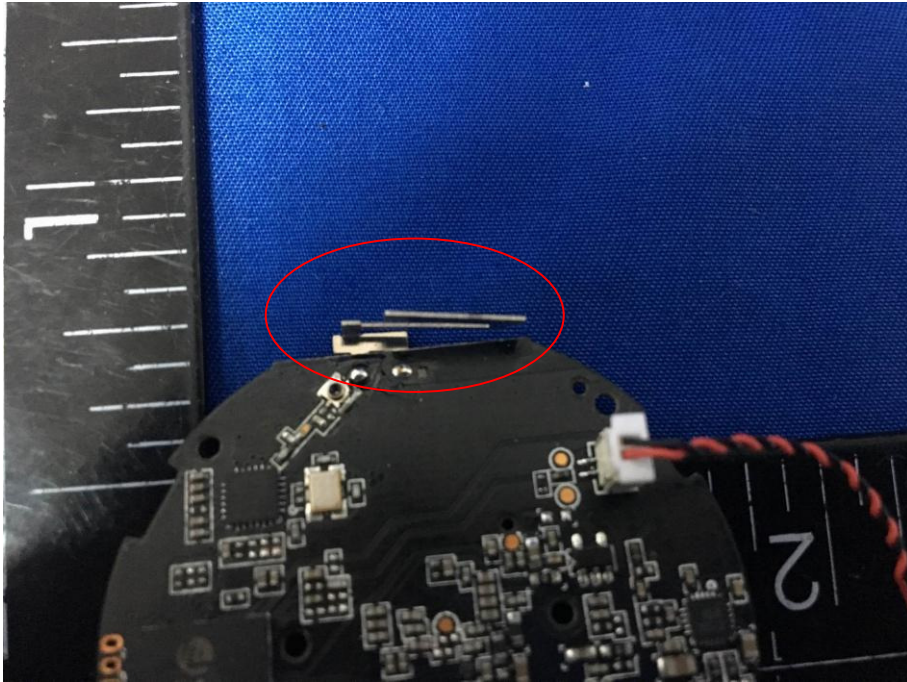

Annex B.iii. Photograph: Test Setup Photo



Conducted Emissions Test Setup Front View



Conducted Emissions Test Setup Side View



Radiated Spurious Emissions Test Setup Below 1GHz

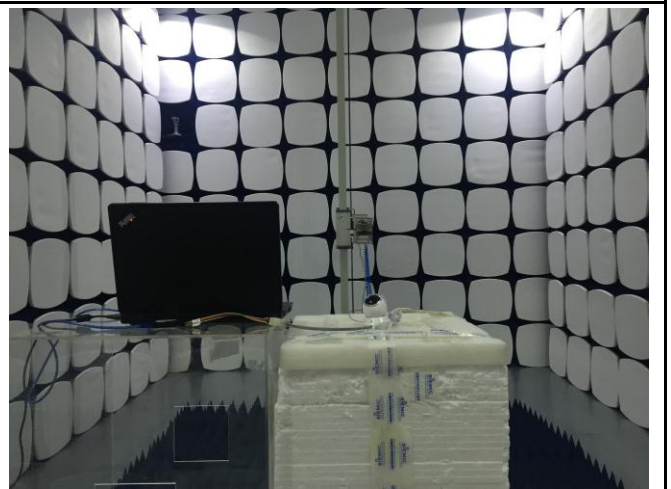

Radiated Spurious Emissions Test Setup Above
1GHz

Annex C. TEST SETUP AND SUPPORTING EQUIPMENT

Annex C.ii. TEST SET UP BLOCK

Block Configuration Diagram for AC Line Conducted Emissions

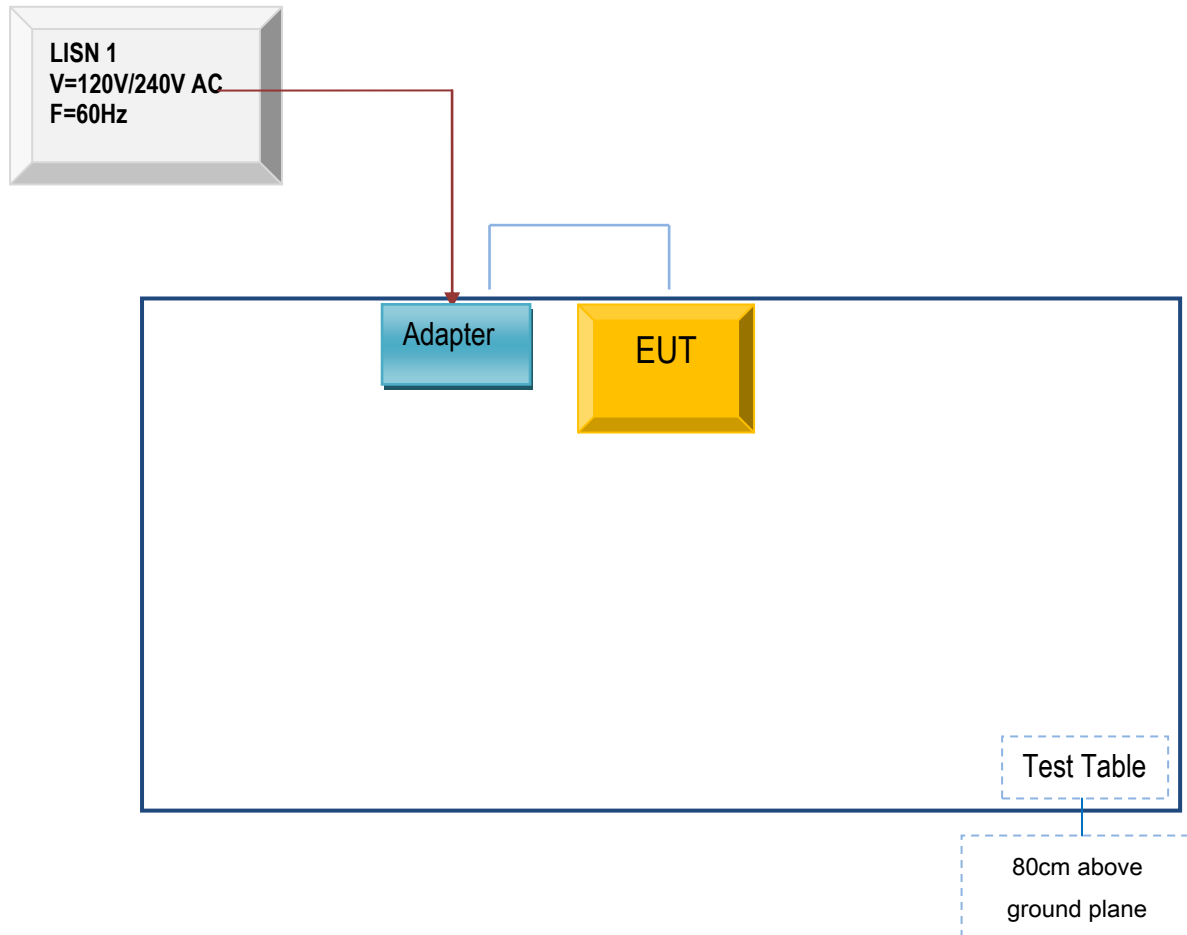

Block Configuration Diagram for Radiated Emissions (Below 1GHz) .

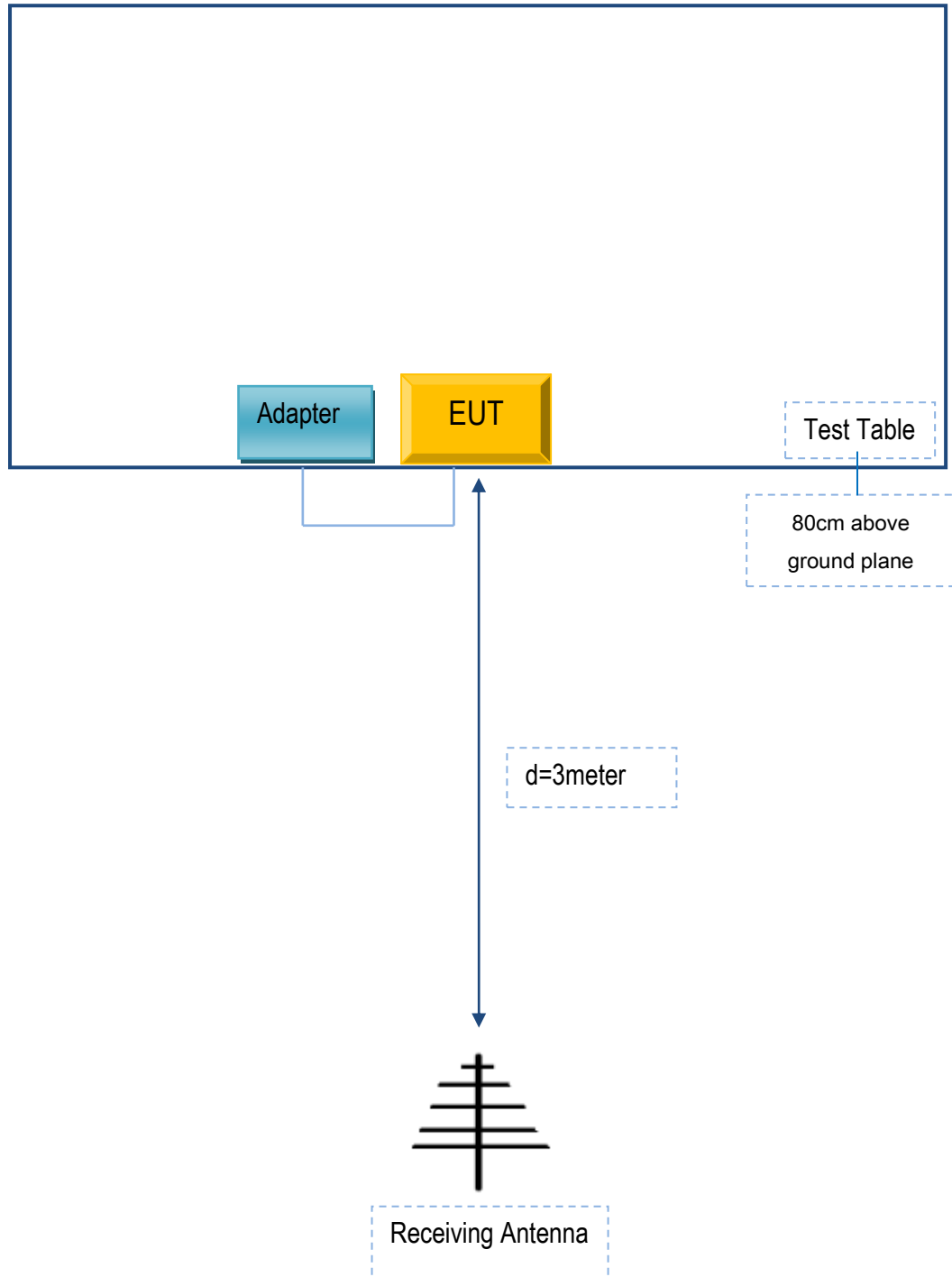

Block Configuration Diagram for Radiated Emissions (Above 1GHz) .

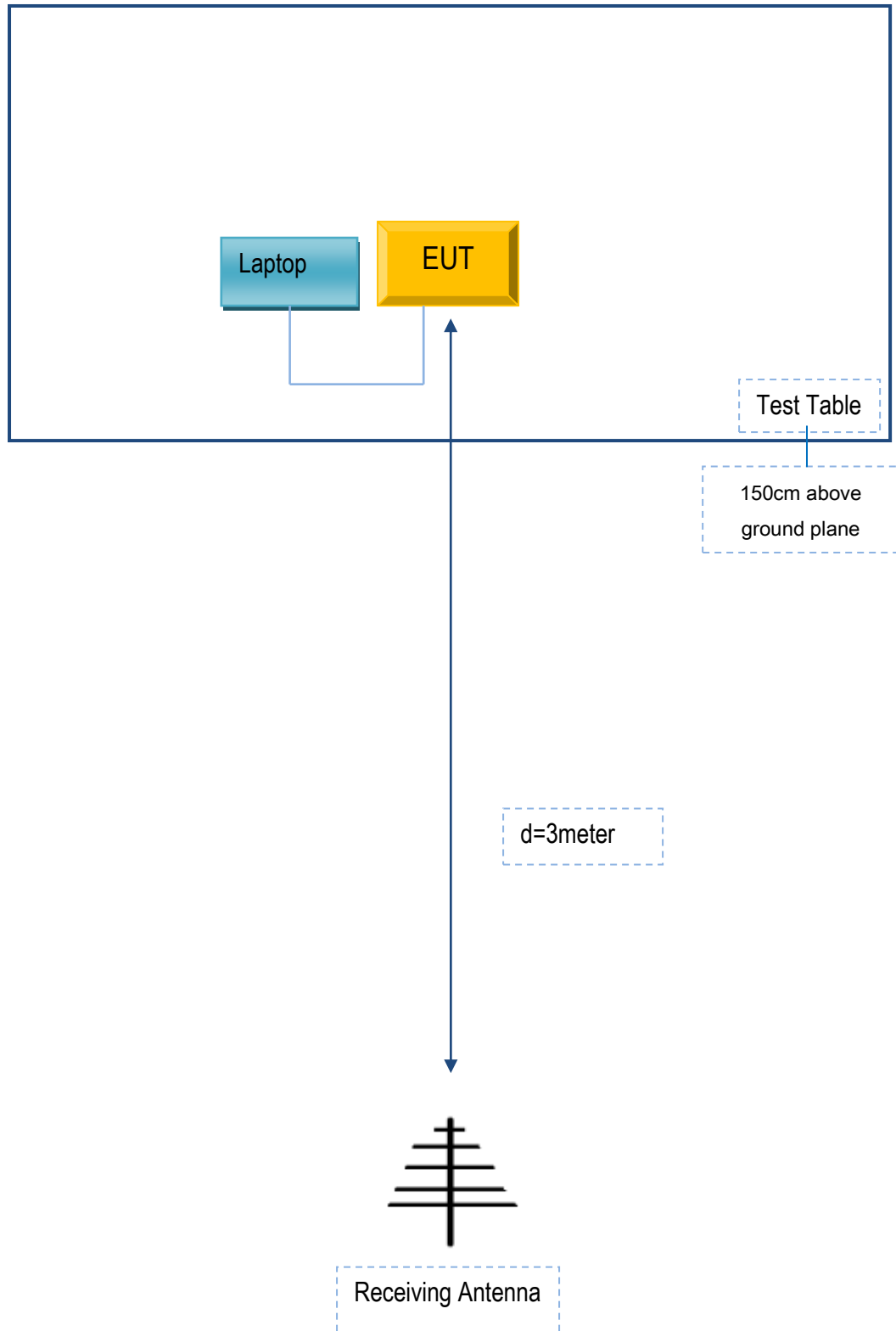

Annex C. ii. SUPPORTING EQUIPMENT DESCRIPTION

The following is a description of supporting equipment and details of cables used with the EUT.

Supporting Equipment:

Manufacturer	Equipment Description	Model	Serial No
Alcidae Inc.	Adapter	TEKA006-0501000UK	N/A
Lenovo	Laptop	E40	N/A

Supporting Cable:

Cable type	Shield Type	Ferrite Core	Length	Serial No
USB Cable	Un-shielding	No	0.8m	N/A

Test Report No.	17071408-FCC-R-V1
Page	63 of 64

Annex D. User Manual / Block Diagram / Schematics / Partlist

Please see the attachment

Test Report No.	17071408-FCC-R-V1
Page	64 of 64

Annex E. DECLARATION OF SIMILARITY

N/A