FCC PART 90S TEST REPORT

Report Number	BWTR-2013-FCCPCE
FCC ID	2AOJA-PTSP
Applicant	SOURCENEXT CORPORATION
Product Name	POCKETALK S Plus
Marketing Name	N/A
Brand Name	SOURCENEXT
Model Name	PTSP
Serial Number	No.1: 864727048560539 No.2: 864727048560471
Test Standard	FCC 47 CFR Part 90 Subpart S
Tested Date	Aug. 20, 2020 – Sep. 10, 2020

CONTENTS

1	Summary of Test Result	4
2	General Information	5
2.1	Applicant.....	5
2.2	Manufacturer	5
2.3	Product Feature of Equipment Under Test	5
2.4	Ancillary Equipment.....	5
2.5	Description of Test Modes	6
2.6	Applicable Standards	7
2.7	Test Facilities.....	7
3	Test Result	8
3.1	RF Output Power.....	8
3.2	Peak to Average Power Ratio (PAPR).....	11
3.3	Effective Radiated Power	13
3.4	Occupied Bandwidth	15
3.5	Spurious Emission at Antenna Terminal.....	24
3.6	Field Strength of Spurious Radiation.....	25
3.7	Band Edge	27
3.8	Frequency Stability.....	31
4	Test Instruments	33

Revision History

Revision	Description	Issued Date
A	Initial issue of report	2020/9/1
B	<ol style="list-style-type: none">1. Remove the EUT information of 64 QAM in section 2.3 and the corresponding test data2. Update the extreme operating temperature information of EUT in section 2.33. Retest and update the data of Frequency Stability based on the change of EUT extreme operating temperature	2020/9/14
C	Update the information of Antenna Type in section 2.3	2020/9/15
D	<ol style="list-style-type: none">1. Update the EUT information of 64 QAM and antenna gain in section 2.32. Add a note information for section 2.3	2020/9/27
E	Update the EUT information of antenna gain in section 2.3	2020/10/23

1 Summary of Test Result

Report Section	FCC Section	Description	Result
3.1	90.635 (b)	RF Output Power	Pass
3.2	KDB 971168 D01 v03 - 5.7	Peak to Average Power Ratio (PAPR)	Pass
3.3	90.635 (b)	Effective Radiated Power	Pass
3.4	90.209 (a)	Occupied Bandwidth	Pass
3.5	90.691	Spurious Emission at Antenna Terminal	Pass
3.6	90.691	Field Strength of Spurious Radiation	Pass
3.7	90.691	Band Edge	Pass
3.8	90.213	Frequency Stability	Pass

We, Beijing Boomwave Test Service Co. Ltd., would like to declare that the tested sample has been evaluated and in compliance with the requirements of applicable standards.

Prepared by: 高雅南 2020.10.23
15:15:04 +08'00'

Reviewed by: 王克 2020.10.23
15:18:13 +08'00'

Approved by: 赵娟 2020.10.23
20:48:24 +08'00'

Rationale:

The test results in this report apply exclusively to the tested model / sample.

The electrical copy of test report is invalid without the signatures. The hard copy is invalid without seal.

The test report shall not be modified, republished or copied without the written authorization of the laboratory.

2 General Information

2.1 Applicant

SOURCENEXT CORPORATION

Shiodome City Center 33F, 1-5-2 Higashi Shimbashi Minato-ku, Tokyo 105-7133

2.2 Manufacturer

SOURCENEXT CORPORATION

Shiodome City Center 33F, 1-5-2 Higashi Shimbashi Minato-ku, Tokyo 105-7133

2.3 Product Feature of Equipment Under Test

Product Name	POCKETALK S Plus
Marketing Name	N/A
Model Name	PTSP
Sample Status	Production
Operating Frequency Range	814MHz~824MHz
Type of Wireless Technology	FDD LTE - Band 26
Modulation Type	QPSK, 16QAM, 64QAM (Downlink Only)
Channel Bandwidth	1.4MHz, 3MHz, 5MHz, 10MHz
Antenna Type	Planner Inverted-F Antenna
Antenna Gain	-3.75dBi
Extreme Operating Temperature	Minimum: -20°C
	Maximum: +50°C
Power Supply	Normal Voltage: 3.80V
	Lowest Voltage: 3.50V
	Highest Voltage: 4.35V
Hardware Version	PT3L_MB_V1.0
Software Version	1.1.6
Sample Received Date	2020/8/18

Note: The EUT has some color variants.

2.4 Ancillary Equipment

The EUT has been tested as an independent unit together with other necessary accessories or support units. The following ancillary equipment were used to form a representative test configuration during the tests.

Support Unit	Li-Lon Battery
Manufacturer	Guangdong Pow-Tech New Power Co.,Ltd
Model Name	PT305070
Capacity	1550mAh
Nominal Voltage	3.8V
Serial Number	---

2.5 Description of Test Modes

The EUT was linked by base station simulator to work in continuous transmitting and receiving mode. Pre-Scan has been conducted to determine the worst-case mode from all possible combinations between available modulations, bandwidth, resource block (RB) and RB offset.

Following channels were selected for test:

Channel Bandwidth	Low Channel		Mid Channel		High Channel	
	Frequency (MHz)	Channel No.	Frequency (MHz)	Channel No.	Frequency (MHz)	Channel No.
1.4MHz	814.7	26697	819.0	26740	823.3	26783
3MHz	815.5	26705	819.0	26740	822.5	26775
5MHz	816.5	26715	819.0	26740	821.5	26765
10MHz	---		819.0	26740	---	

Following modes were selected as the worst case configuration for each test:

Test Items	Channel	BW (MHz)	RB Size	RB Offset	Modulation	Antenna Orientation
RF Output Power	L\M\H	1.4	1\3\6	0\5\2	QPSK,16QAM	N/A
		3	1\8\15	0\14\4		
		5	1\12\25	0\24\6		
		10	1\24\50	0\49\12		
Peak to Average Power Ratio	M	1.4\3\5\10	1	0	QPSK,16QAM	N/A
Effective Radiated Power	L\M\H	1.4\3\5\10	1	0	QPSK,16QAM	X axis
Occupied Bandwidth	L\M\H	1.4	6	0	QPSK,16QAM	N/A
		3	15			
		5	25			
		10	50			
Spurious Emission at Antenna Terminal	M	10	1	0	QPSK	N/A
Field Strength of Spurious Radiation	M	10	1	0	QPSK	X axis
Band Edge	L\H	1.4	1\6	0\5	QPSK	N/A
		3	1\15	0\14		
		5	1\25	0\24		
		10	1\50	0\49		
Frequency Stability	L\H	1.4\3\5\10	1	0	QPSK	N/A

2.6 Applicable Standards

Standard	Version	Title
FCC 47 CFR Part 90 Subpart S	2019	Regulations Governing Licensing and Use of Frequencies in the 806-824, 851-869, 896-901, and 935-940 MHz Bands
ANSI C63.26	2015	American National Standard for Compliance Testing of Transmitters Used in Licensed Radio Services

2.7 Test Facilities

Company Name: Beijing Boomwave Test Service Co. Ltd

Address: EMC Building, No.1 Wang Jing East Road, Chao Yang District Beijing, P.R. China 100102

FCC Test Firm Registration Number: 613197

ISED Canada Registration No.: 24289 (CAB Identifier: CN0010)

VCCI Registration No.: R-20062, G-20063, C-20050, T-20049

Test Site	Description	Dimension	Ground Plane Size
<input type="checkbox"/> SAC10	10m semi-anechoic chamber	19.5m×12.9m×8.6m	4m×4m
<input checked="" type="checkbox"/> SAC3	3m semi-anechoic chamber	9.6m×6.4m×6.0m	9.6m×6.4m
<input type="checkbox"/> SR#1	Shielding Room for EMS test	8.1m×4.05m×2.755m	8.1m×4.05m
<input checked="" type="checkbox"/> SR#2	Shielding Room for RF test	8.1m×4.05m×2.755m	---

3 Test Result

3.1 RF Output Power

3.1.1. Limit

FCC 47 CFR Part 90 Subpart S - §90.635(b)
The maximum output power of the transmitter for mobile station is 100 watts (20dBw).

3.1.2. Test Setup

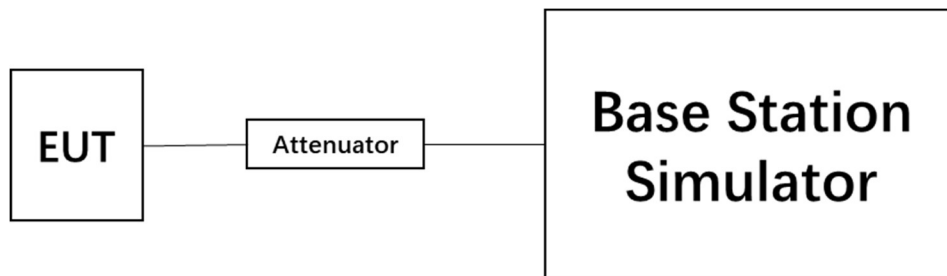

3.1.3. Test Procedures

- 1) The measurement procedure follows ANSI C63.26-2015, clause 5.2.
- 2) The RF output of EUT and BS simulator are connected via a sufficient attenuation.
- 3) EUT is configured to transmit the maximum output power while the measurement is performed.

3.1.4. Test Result

Test Engineer	Xu Dongxu	Test Date	2020.08.20
Temperature	22.0°C	Relative Humidity	51.1%
Pressure	101.6kPa	Test Sample Selected	No.1

Modulation Type	Frequency (MHz)	BW (MHz)	RB Size	RB Offset	Output Power (dBm)
QPSK	814.7	1.4	1	0	21.64
			1	5	21.66
			3	2	20.83
			6	0	20.80
	819.0		1	0	21.53
			1	5	21.58
			3	2	20.73
			6	0	20.85
	823.3		1	0	21.50
			1	5	21.63
			3	2	20.82
			6	0	20.65
16QAM	814.7	1.4	1	0	20.79
			1	5	20.77
			3	2	19.86
			6	0	19.72
	819.0		1	0	20.88
			1	5	20.95
			3	2	19.83
			6	0	19.67
	823.3		1	0	20.82
			1	5	20.88
			3	2	19.83
			6	0	19.60

Modulation Type	Frequency (MHz)	BW (MHz)	RB Size	RB Offset	Output Power (dBm)
QPSK	815.5	3	1	0	21.47
			1	14	21.57
			8	4	20.68
			15	0	20.80
	819.0		1	0	21.59
			1	14	21.70
			8	4	20.70
			15	0	20.79
	822.5		1	0	21.49
			1	14	21.65
			8	4	20.76
			15	0	20.65
16QAM	815.5	3	1	0	20.87
			1	14	20.85
			8	4	19.79
			15	0	19.62
	819.0		1	0	20.92
			1	14	20.94
			8	4	19.78
			15	0	19.72
	822.5		1	0	20.77
			1	14	20.90
			8	4	19.70
			15	0	19.68

Modulation Type	Frequency (MHz)	BW (MHz)	RB Size	RB Offset	Output Power (dBm)
QPSK	816.5	5	1	0	21.76
			1	24	21.76
			12	6	20.95
			25	0	20.93
	819.0		1	0	21.81
			1	24	21.81
			12	6	20.95
			25	0	20.95
	821.5		1	0	21.78
			1	24	21.78
			12	6	20.95
			25	0	20.93
16QAM	816.5	5	1	0	21.01
			1	24	21.01
			12	6	19.98
			25	0	19.90
	819.0		1	0	21.07
			1	24	21.07
			12	6	19.98
			25	0	19.92
	821.5		1	0	21.06
			1	24	21.06
			12	6	19.94
			25	0	19.87

Modulation Type	Frequency (MHz)	BW (MHz)	RB Size	RB Offset	Output Power (dBm)
QPSK	819.0	10	1	0	21.85
			1	49	21.85
			24	12	20.97
			50	0	21.00
16QAM	819.0	10	1	0	21.10
			1	49	21.10
			24	12	19.99
			50	0	19.98

3.1.5. Uncertainty

$$U_{lab}=1.48\text{dB} (k=2)$$

3.2 Peak to Average Power Ratio (PAPR)

3.2.1. Limit

In measuring transmissions in this band using an average power technique, the peak-to-average ratio (PAR) of the transmission may not exceed 13dB.

3.2.2. Test Setup

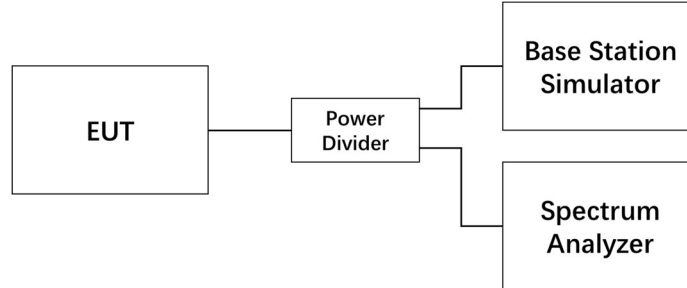

3.2.3. Test Procedures

- 1) The measurement procedure follows ANSI C63.26-2015, clause 5.2.6.
- 2) The RF output of the EUT, BS simulator and spectrum analyzer are connected via a power divider.
- 3) Measure the total peak power and record as P_{Pk} .
- 4) Measure the total average power and record as P_{Avg} .
- 5) Calculate the PAPR from: $PAPR (dB) = P_{Pk} (dBm) - P_{Avg} (dBm)$.

3.2.4. Test Result

Test Engineer	Xu Dongxu	Test Date	2020.08.23
Temperature	21.8°C	Relative Humidity	49.1%
Pressure	101.6kPa	Test Sample Selected	No.1

Frequency (MHz)	Channel No.	BW (MHz)	RB Size	RB Offset	QPSK	16-QAM
819.0	26740	1.4	1	0	Fig.1	Fig.2
		3	1	0	Fig.3	Fig.4
		5	1	0	Fig.5	Fig.6
		10	1	0	Fig.7	Fig.8

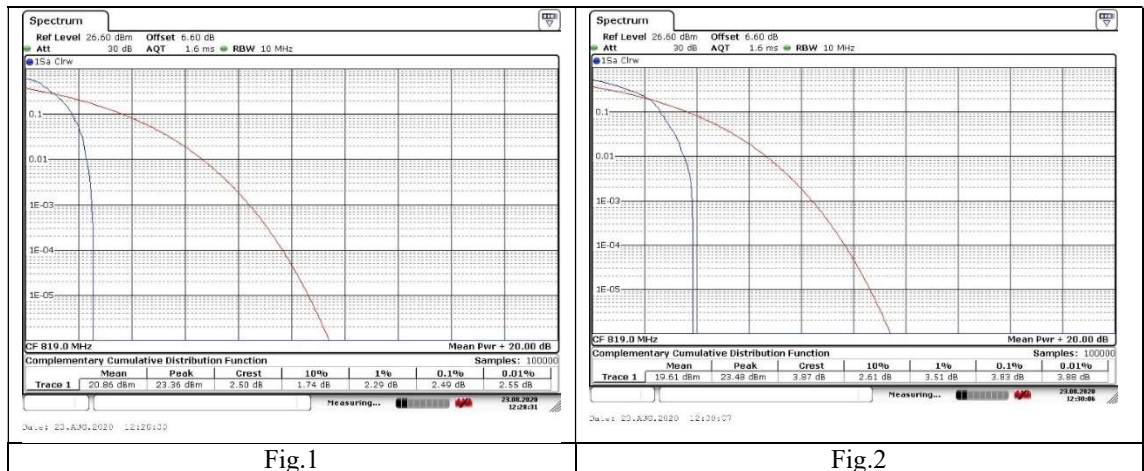

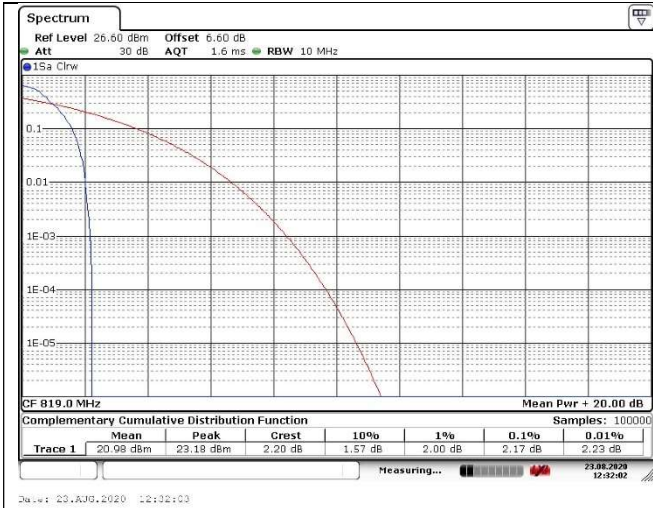

Fig.3

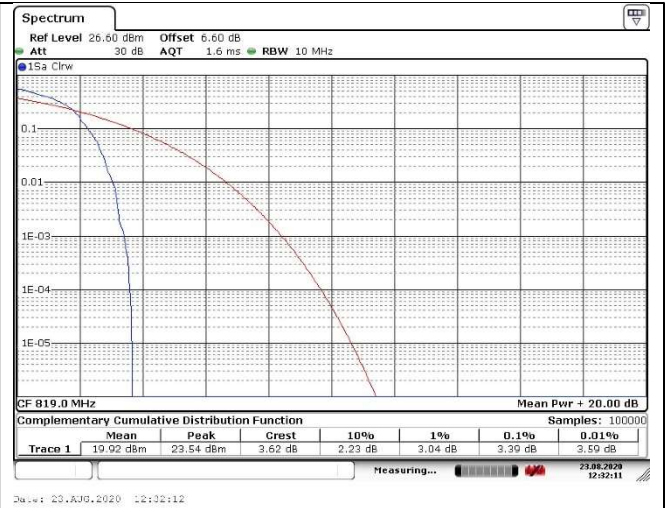

Fig.4



Fig.5



Fig.6

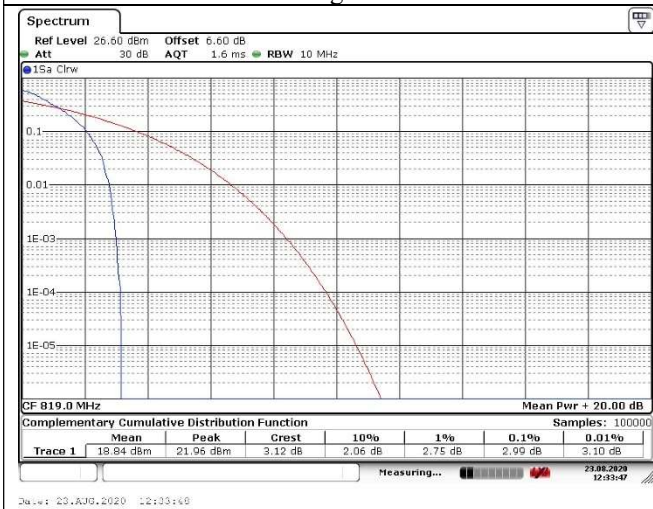

Fig.7

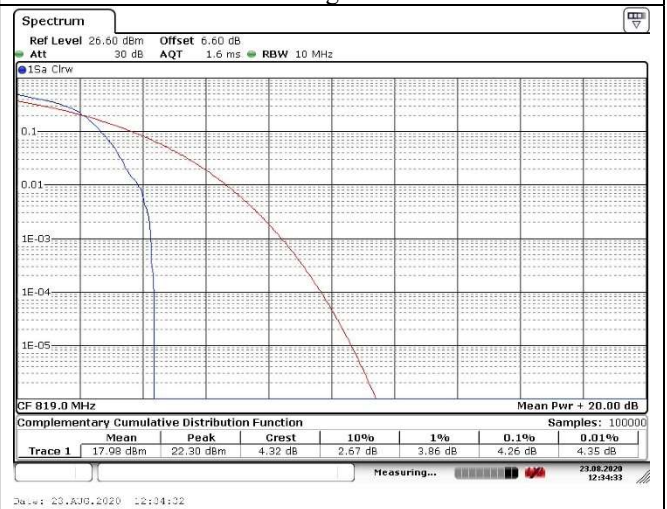

Fig.8

3.2.5. Uncertainty

$$U_{lab}=1.48\text{dB} (k=2)$$

3.3 Effective Radiated Power

3.3.1. Limit

FCC 47 CFR Part 90 Subpart S - §90.635 (b)

The maximum output power of the transmitter for mobile station is 100 watts (20dBw).

3.3.2. Test Setup

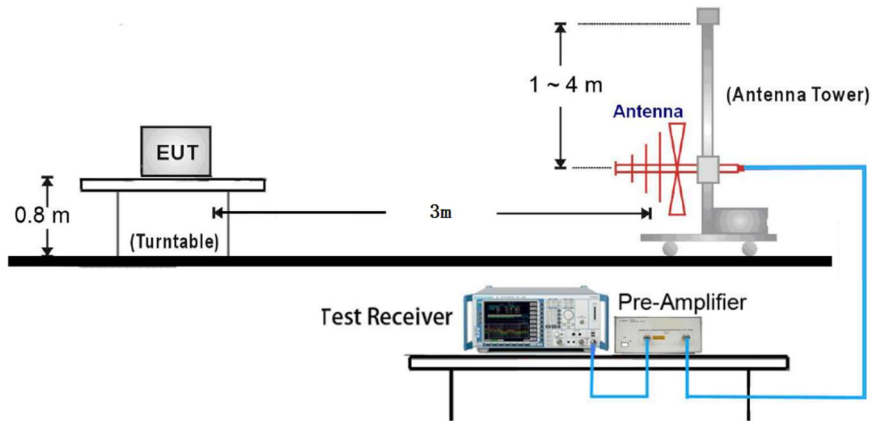

3.3.3. Test Procedures

- 1) The measurement procedure follows ANSI C63.26-2015, clause 5.2.7.
- 2) Connect the equipment as illustrated. Mount the equipment with the manufacturer specified antenna in a vertical orientation on a manufacturer specified mounting surface located on a non-conducting rotating platform of a RF anechoic chamber (preferred) or a standard radiation site.
- 3) Key the transmitter, then rotate the EUT 360° azimuthally and record spectrum analyzer power level (LVL) measurements at angular increments that are sufficiently small to permit resolution of all peaks. If a standard radiation test site is used, raise and lower the test antenna to obtain a maximum reading at each angular increment. (Note: several batteries may be needed to offset the effect of battery voltage droop, which should not exceed 5% of the manufactured specified battery voltage during transmission).
- 4) Replace the transmitter under test with a vertically polarized half-wave dipole (or an antenna whose gain is known relative to an ideal half-wave dipole). The center of the antenna should be at the same location as the center of the antenna under test.
- 5) Connect the antenna to a signal generator with a known output power and record the path loss (in dB) as LOSS. If a standard radiation test site is used, raise and lower the test antenna to obtain a maximum reading. $LOSS = \text{Generator Output Power (dBm)} - \text{Analyzer reading (dBm)}$.
- 6) Determine the effective radiated output power at each angular position from the readings in steps 2) and 4) using the following equation: $ERP \text{ (dBm)} = LVL \text{ (dBm)} + LOSS \text{ (dB)}$
- 7) The maximum ERP is the maximum value determined in the preceding step.
- 8) When calculating ERP, in addition to knowing the antenna radiation and matching characteristics, it is necessary to know the loss values of all elements (e.g. transmission line attenuation, mismatches, filters, combiners) interposed between the point where transmitter output power is measured, and the point where power is applied to the antenna. ERP can then be calculated as follows:

$$EIRP \text{ (dBm)} = \text{Output Power (dBm)} - \text{Losses (dB)} + \text{Antenna Gain (dBi)}$$

where: dB refers to gain relative to an ideal dipole.

$$EIRP \text{ (dBm)} = ERP \text{ (dBm)} + 2.15 \text{ (dB)}$$

The RB allocation refers the configuration of maximum output power.

3.3.4. Test Result

Test Engineer	Gao Yanan	Test Date	2020.8.26
Temperature	25.1°C	Relative Humidity	50.9%
Pressure	103.1kPa	Test Sample Selected	No.2

Modulation	BW (MHz)	Frequency (MHz)	RB/RB offset	EIRP/ERP (dBm)	EIRP/ERP (W)
QPSK	1.4	814.7	1#0	20.84	0.121
QPSK	1.4	819.0	1#0	20.73	0.118
QPSK	1.4	823.3	1#0	20.70	0.117
16QAM	1.4	814.7	1#0	19.99	0.100
16QAM	1.4	819.0	1#0	20.08	0.102
16QAM	1.4	823.3	1#0	20.02	0.100
QPSK	3	815.5	1#0	20.67	0.117
QPSK	3	819.0	1#0	20.79	0.120
QPSK	3	822.5	1#0	20.69	0.117
16QAM	3	815.5	1#0	20.07	0.102
16QAM	3	819.0	1#0	20.12	0.103
16QAM	3	822.5	1#0	19.97	0.099
QPSK	5	816.5	1#0	20.96	0.125
QPSK	5	819.0	1#0	21.01	0.126
QPSK	5	821.5	1#0	20.98	0.125
16QAM	5	816.5	1#0	20.21	0.105
16QAM	5	819.0	1#0	20.27	0.106
16QAM	5	821.5	1#0	20.26	0.106
QPSK	10	819.0	1#0	21.05	0.127
16QAM	10	819.0	1#0	20.30	0.107

3.3.5. Uncertainty

$$U_{lab}=3.24\text{dB} (k=2)$$

3.4 Occupied Bandwidth

3.4.1. Limit

FCC 47 CFR Part 90 Subpart S - §90.209 (a)

Each authorization issued to a station licensed under this part will show an emission designator representing the class of emission authorized. The designator will be prefixed by a specified necessary bandwidth. This number does not necessarily indicate the bandwidth occupied by the emission at any instant. In those cases where §2.202 of this chapter does not provide a formula for the computation of necessary bandwidth, the occupied bandwidth, as defined in part 2 of this chapter, may be used in lieu of the necessary bandwidth.

3.4.2. Test Setup

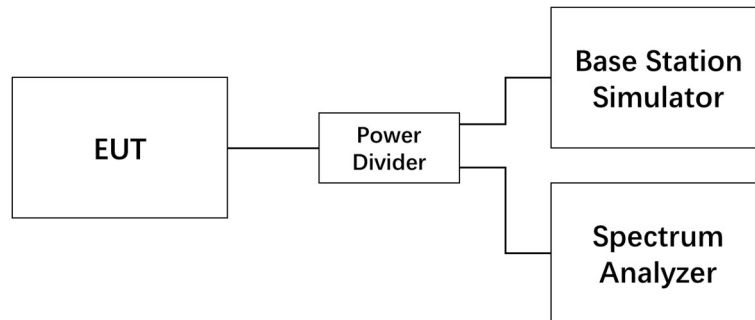

3.4.3. Test Procedures

- 1) The measurement procedure follows ANSI C63.26-2015, clause 5.2.7
- 2) The RF output of the EUT, BS simulator and spectrum analyzer are connected via a power divider.
- 3) The nominal RBW of spectrum analyzer shall be in the range of 1% to 5% of the anticipated OBW, and the VBW shall be set $\geq 3 \times$ RBW.
- 4) Record the measured results of 26dB and 99% bandwidth.

3.4.4. Test Result

Test Engineer	Xu Dongxu	Test Date	2020.08.20
Temperature	22.0°C	Relative Humidity	51.1%
Pressure	101.6kPa	Test Sample Selected	No.1

Frequency (MHz)	Channel No.	BW (MHz)	RB Size	RB Offset	Bandwidth of -26dB (MHz)			
					QPSK		16-QAM	
814.7	26697	1.4	6	0	1.086	Fig.1	1.086	Fig.2
819.0	26740		6	0	1.094	Fig.3	1.094	Fig.4
823.3	26783		6	0	1.086	Fig.5	1.086	Fig.6
815.5	26705	3	15	0	2.692	Fig.7	2.683	Fig.8
819.0	26740		15	0	2.692	Fig.9	2.683	Fig.10
822.5	26775		15	0	2.674	Fig.11	2.683	Fig.12
816.5	26715	5	25	0	4.501	Fig.13	4.501	Fig.14
819.0	26740		25	0	4.515	Fig.15	4.501	Fig.16
821.5	26765		25	0	4.486	Fig.17	4.486	Fig.18
819.0	26740	10	50	0	9.030	Fig.19	9.030	Fig.20

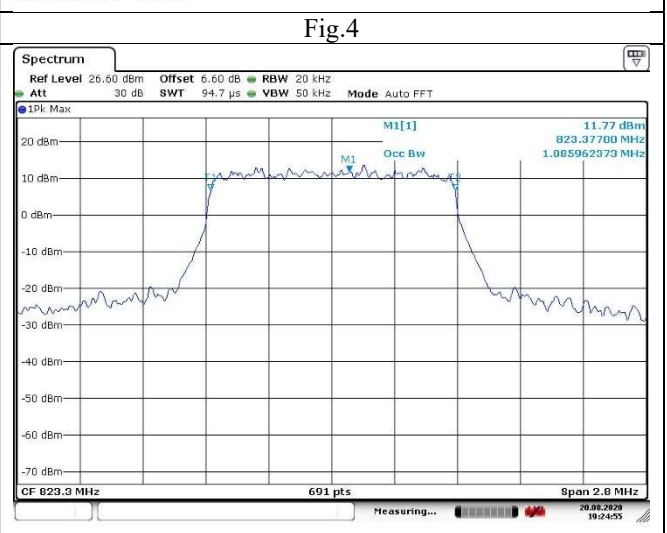
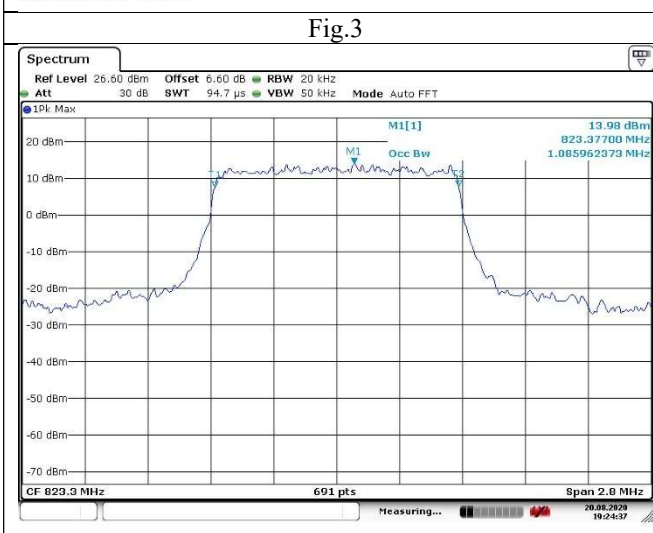
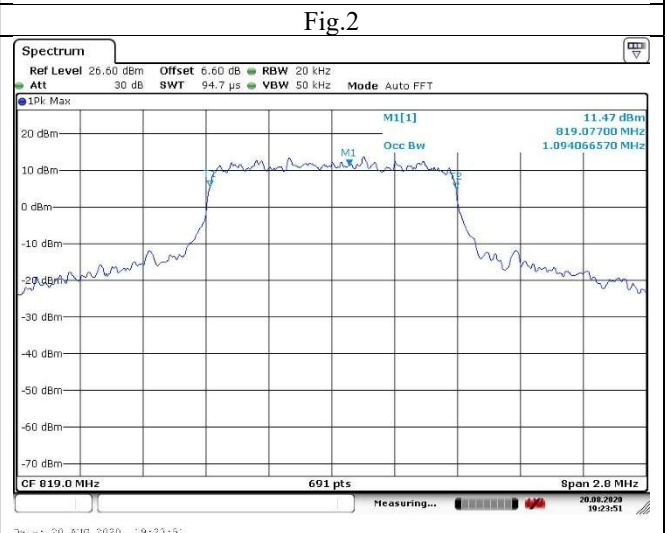
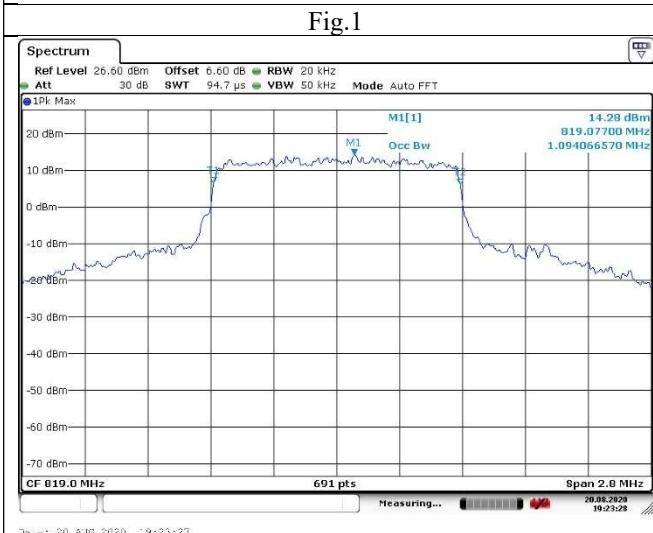
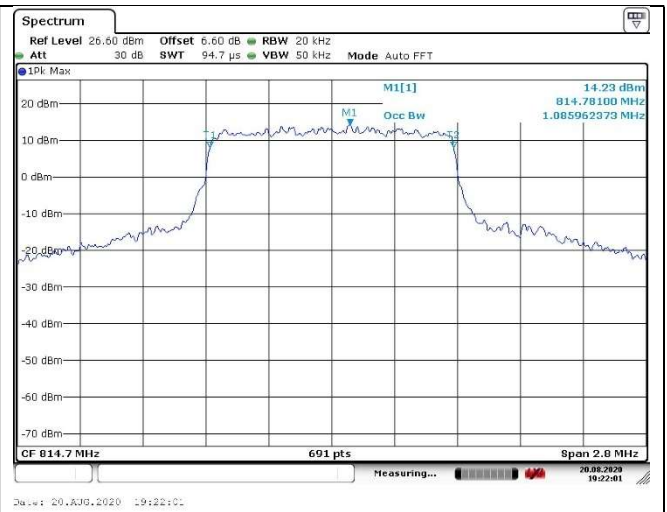
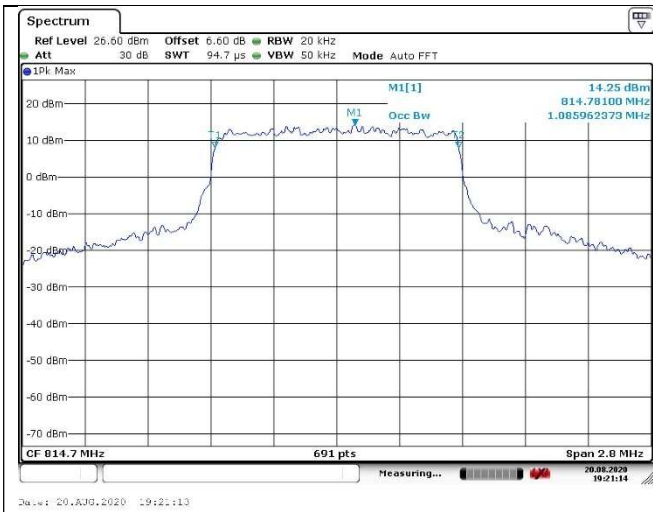

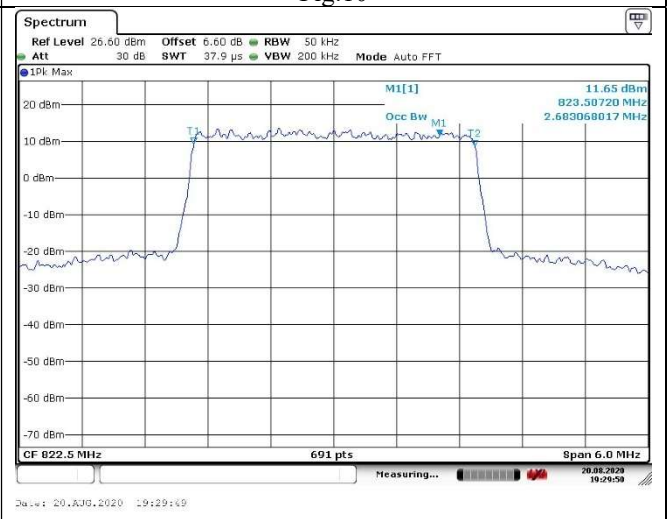
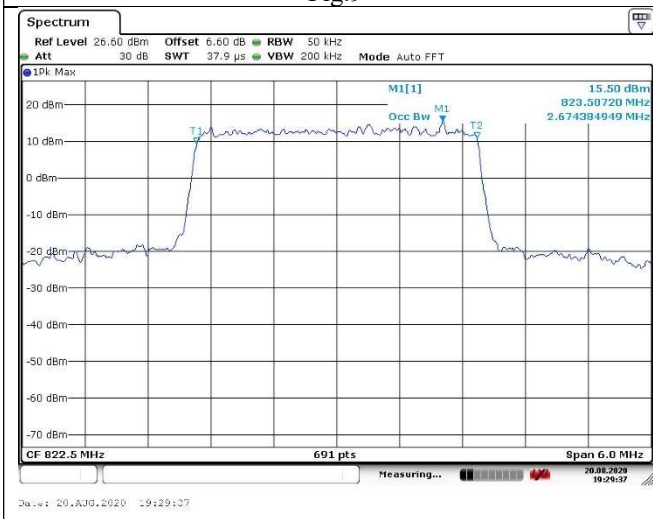
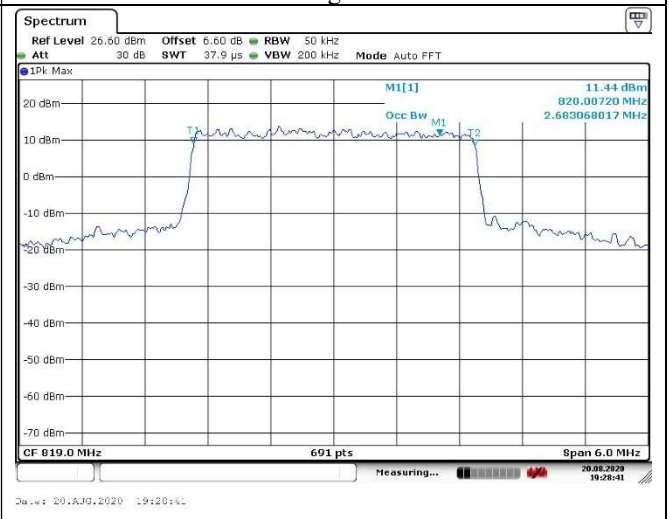
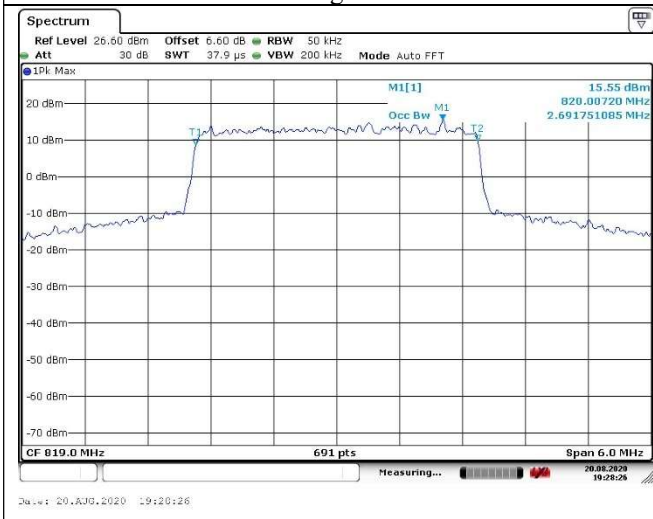
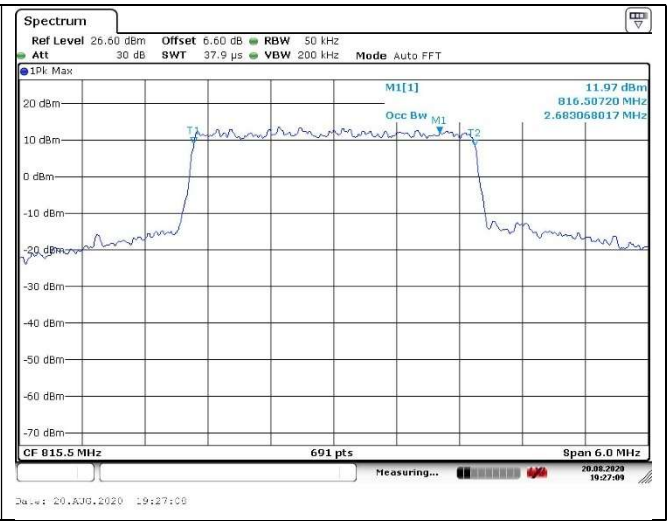
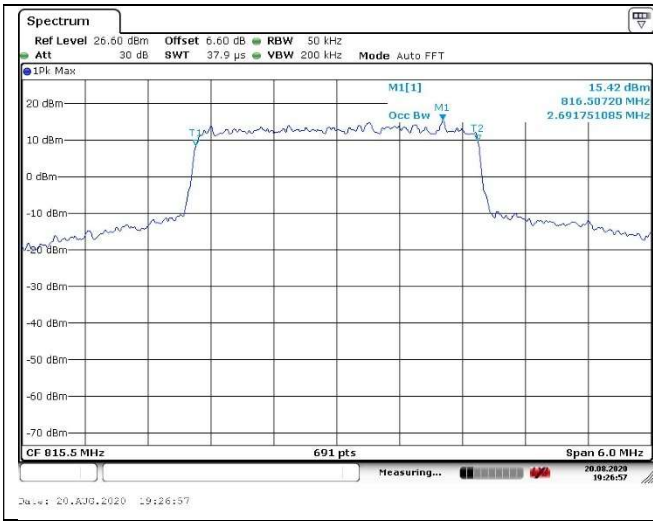

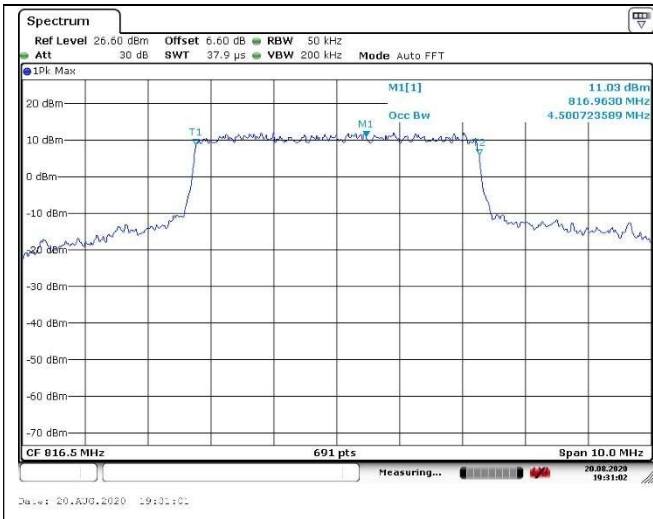

Fig.13

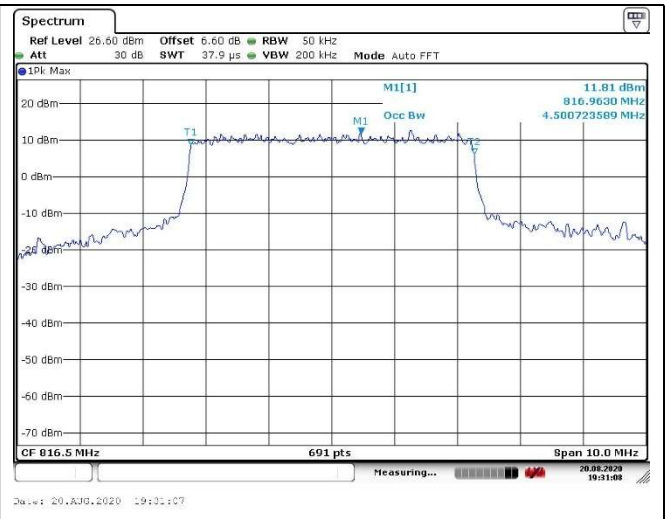

Fig.14

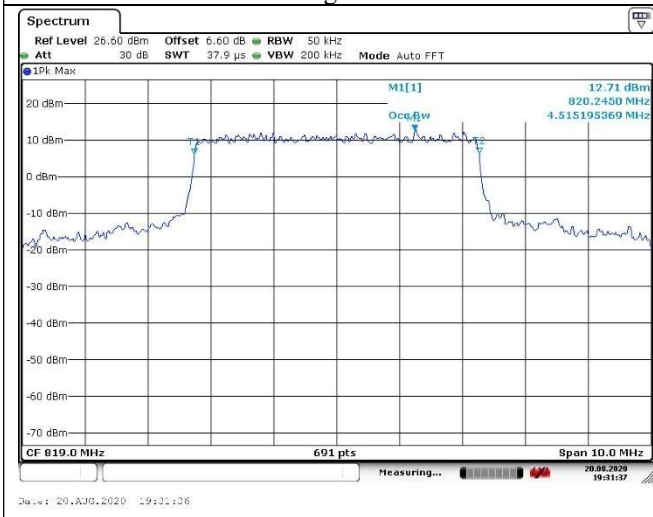

Fig.15

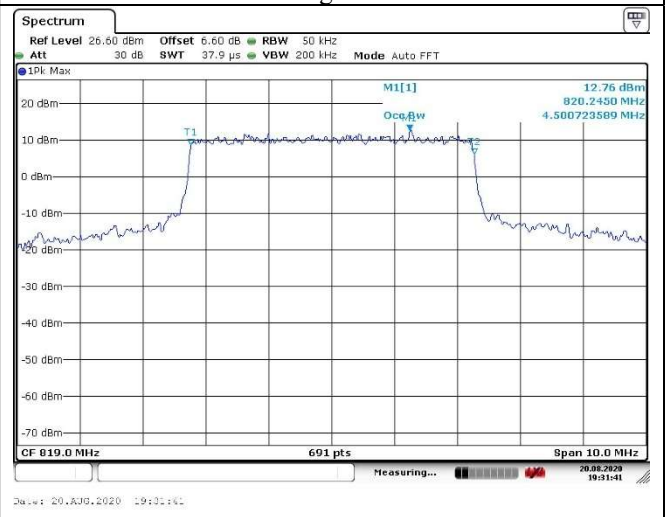

Fig.16

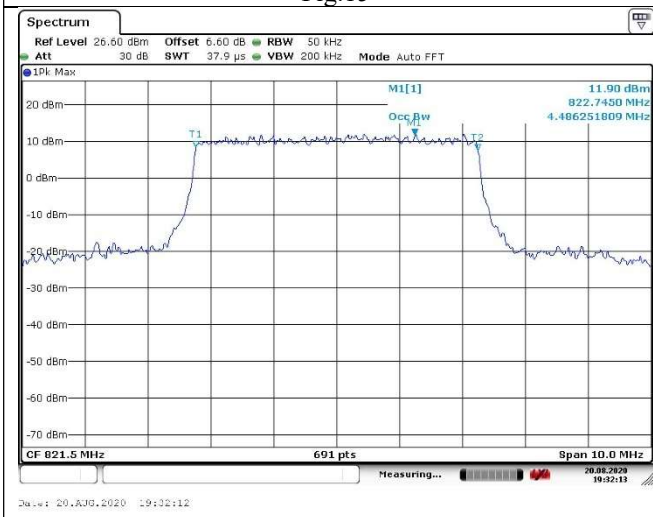

Fig.17

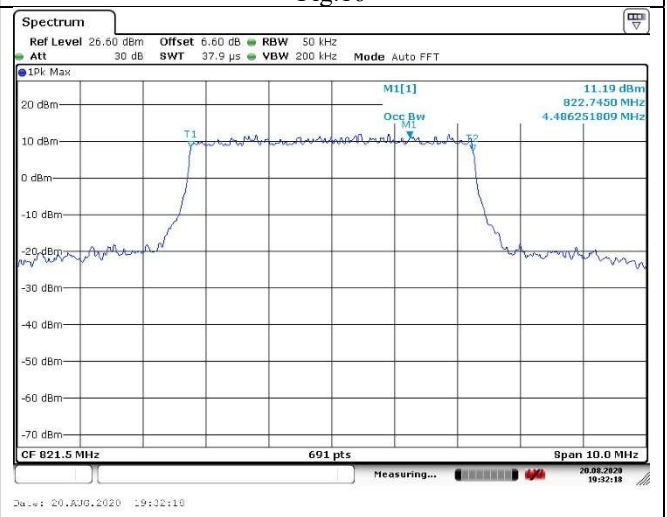
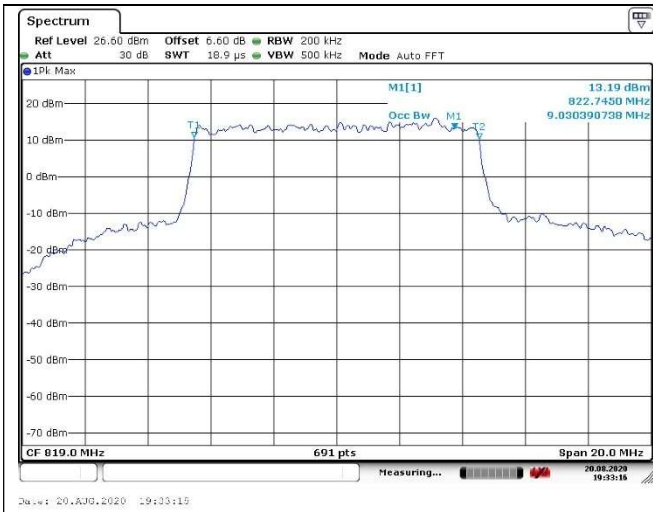
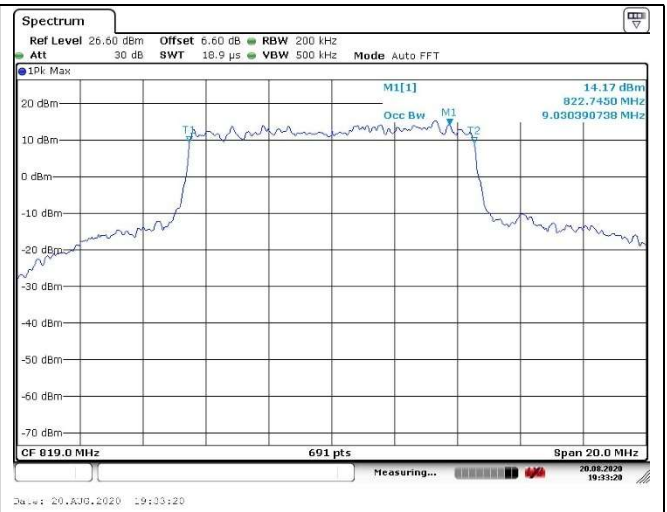

Fig.18

Fig.19

Fig.20

Test Engineer	Xu Dongxu	Test Date	2020.08.24
Temperature	22.5°C	Relative Humidity	50.9%
Pressure	102.5kPa	Test Sample Selected	No.1

Frequency (MHz)	Channel No.	BW (MHz)	RB Size	RB Offset	Bandwidth of -26dB (MHz)			
					QPSK		16-QAM	
814.7	26697	1.4	6	0	1.293	Fig.1	1.276	Fig.2
819.0	26740		6	0	1.426	Fig.3	1.204	Fig.4
823.3	26783		6	0	1.426	Fig.5	1.305	Fig.6
815.5	26705	3	15	0	2.944	Fig.7	2.926	Fig.8
819.0	26740		15	0	3.534	Fig.9	2.944	Fig.10
822.5	26775		15	0	2.891	Fig.11	2.909	Fig.12
816.5	26715	5	25	0	5.818	Fig.13	5.152	Fig.14
819.0	26740		25	0	5.137	Fig.15	5.152	Fig.16
821.5	26765		25	0	5.080	Fig.17	5.109	Fig.18
819.0	26740	10	50	0	10.507	Fig.19	9.957	Fig.20

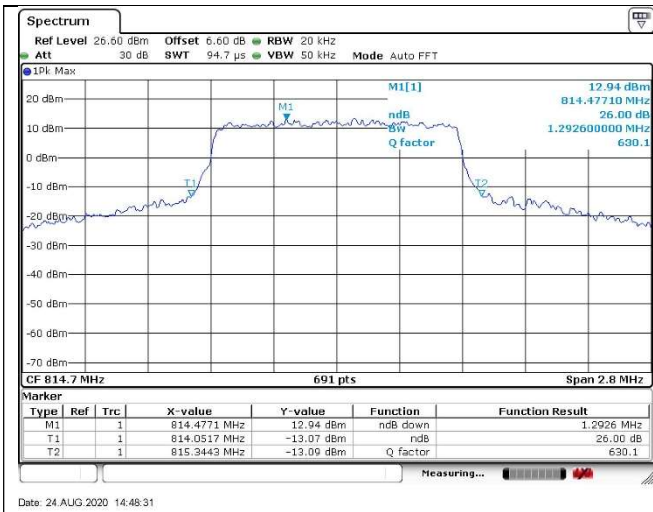

Fig.1

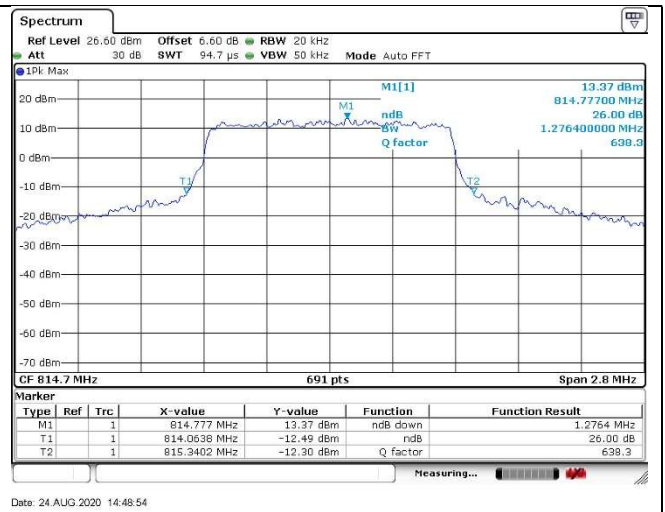

Fig.2

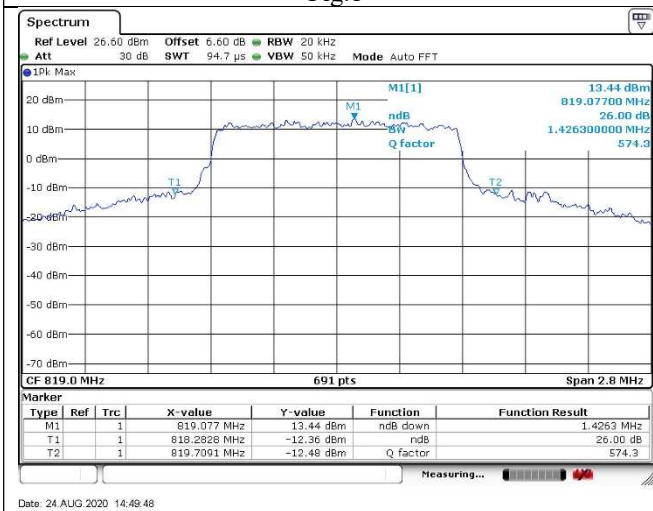

Fig.3

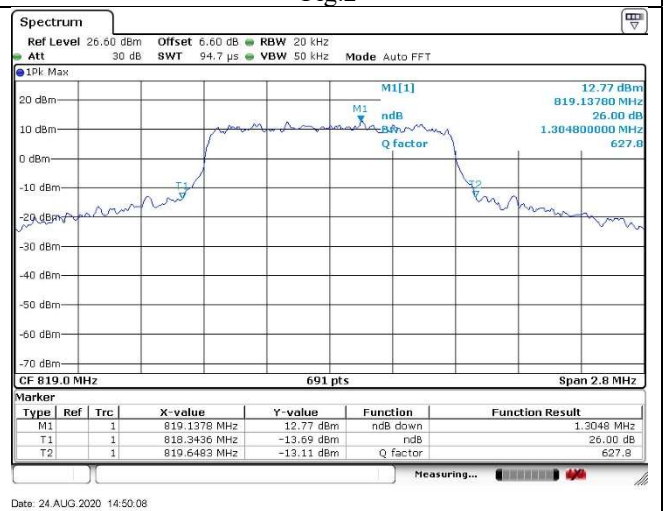

Fig.4

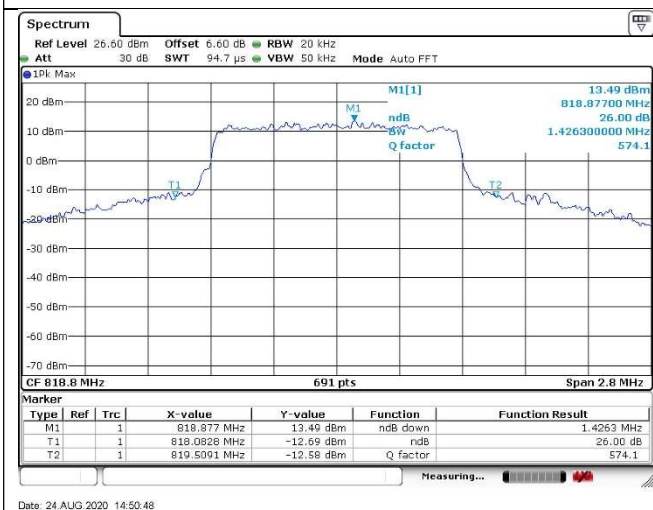

Fig.5

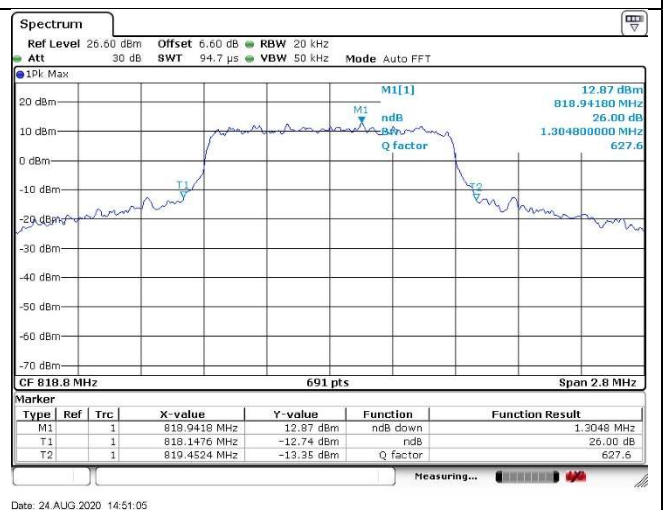
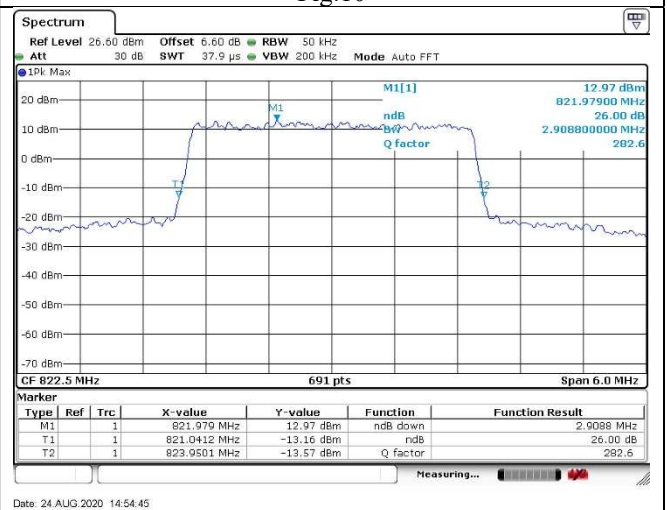
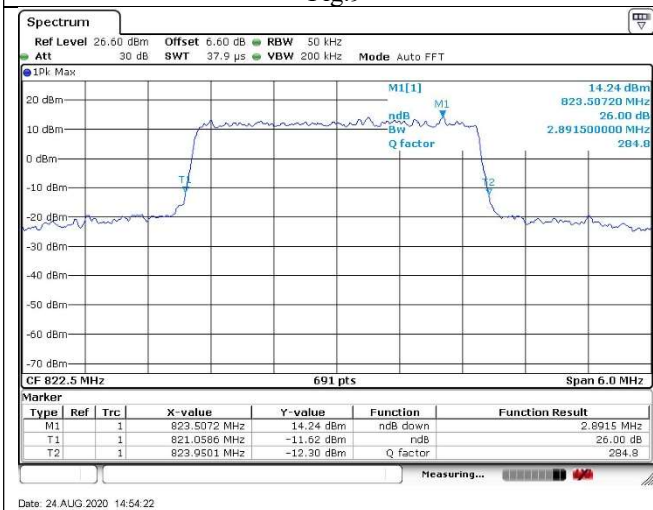
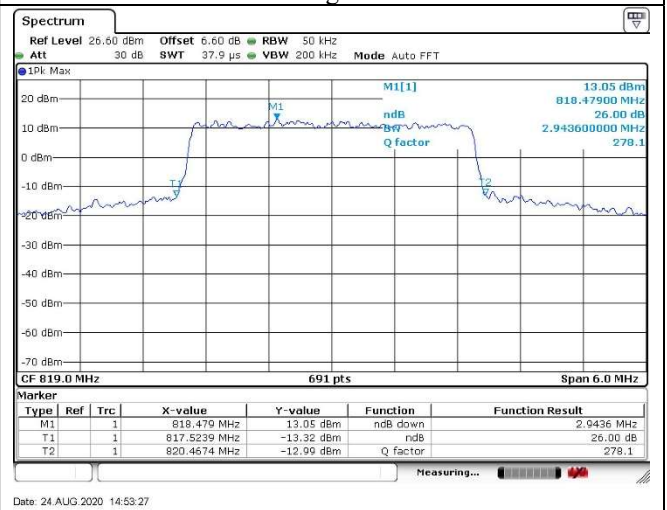
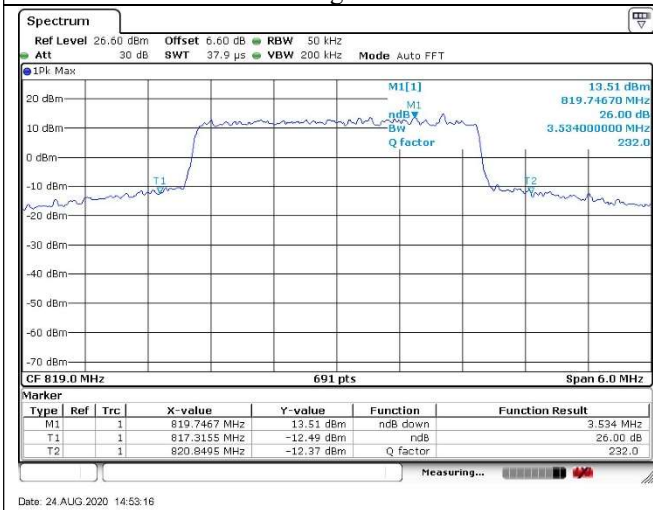
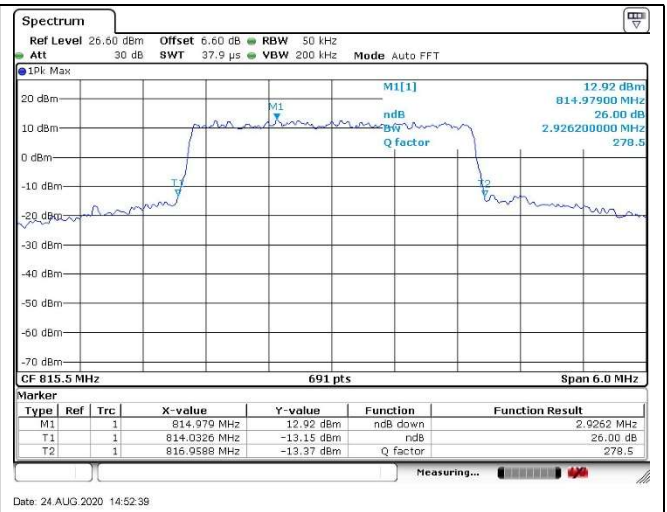
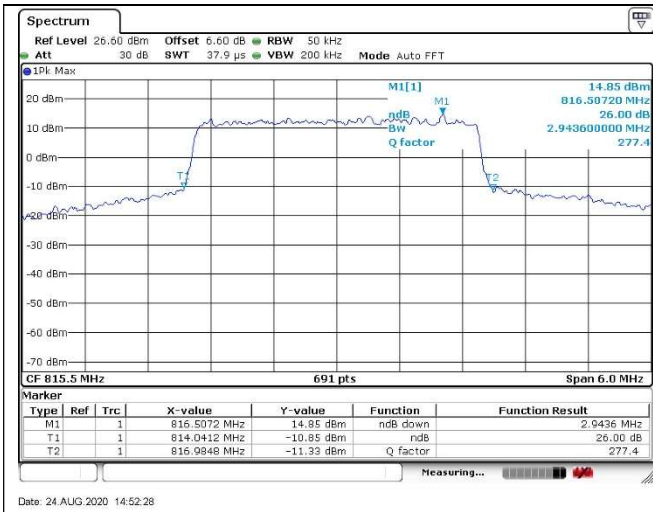

Fig.6



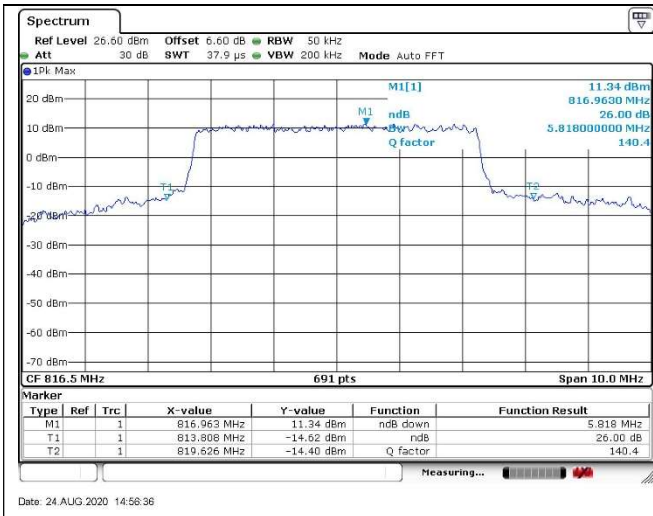

Fig.13

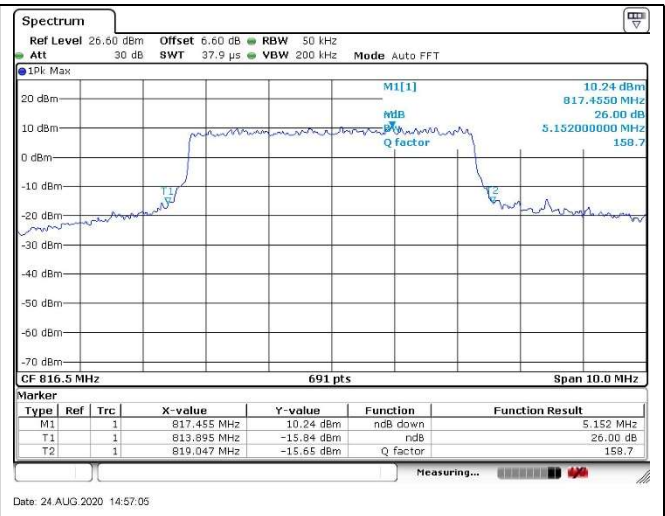

Fig.14

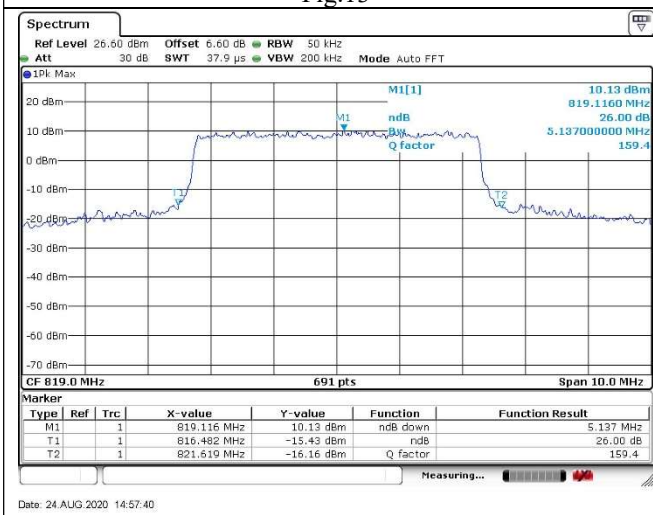

Fig.15

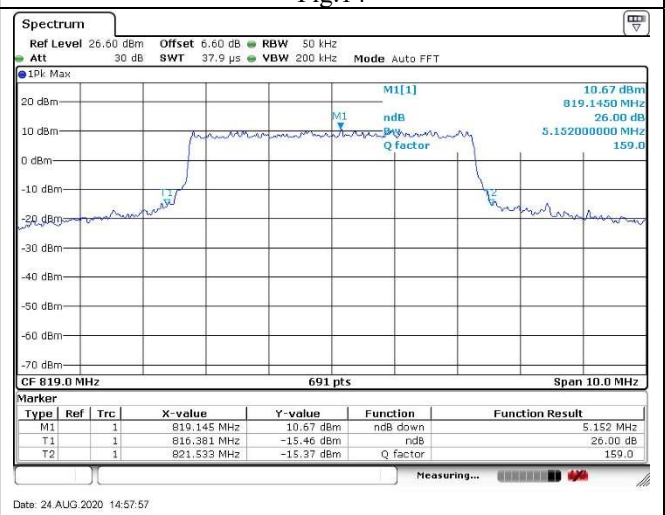

Fig.16

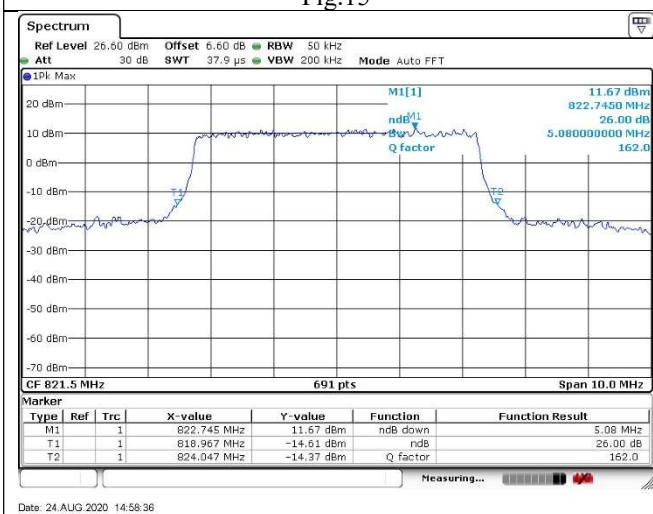

Fig.17

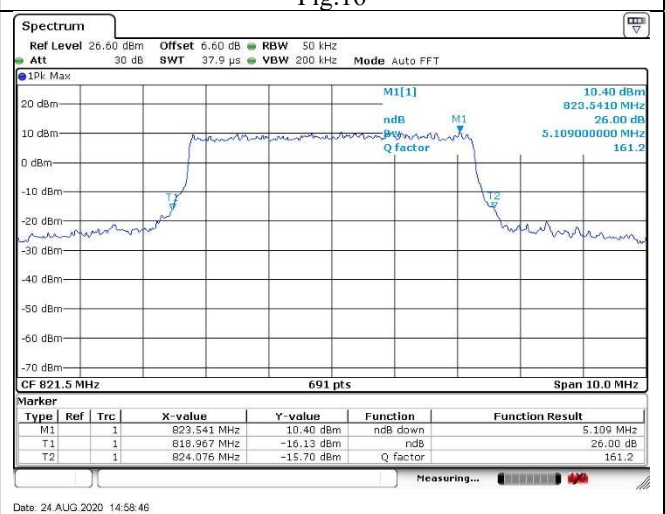
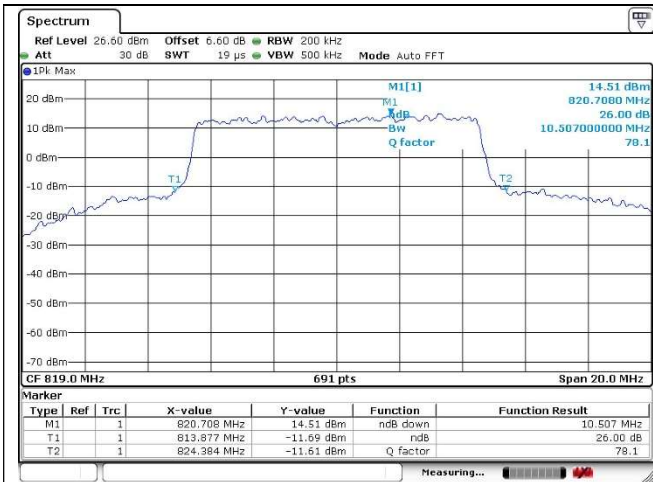
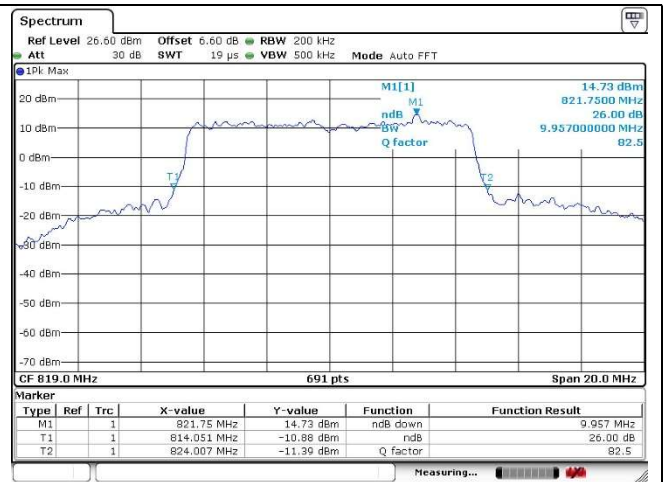

Fig.18

Fig.19

Fig.20

3.4.5. Uncertainty

Frequency (MHz)	U_{lab}	k
814.7	71.15Hz	2
819.0	71.44Hz	2
823.3	71.73Hz	2
815.5	71.21Hz	2
822.5	71.68Hz	2
816.5	71.27Hz	2
821.5	71.61Hz	2

3.5 Spurious Emission at Antenna Terminal

3.5.1. Limit

FCC 47 CFR Part 90 Subpart S - §90.691

For any frequency removed from the EA licensee's frequency block greater than 37.5 kHz, the power of any emission shall be attenuated below the transmitter power (P) in watts by at least $43 + 10\text{Log}_{10}(P)$ decibels or 80 decibels, whichever is the lesser attenuation, where f is the frequency removed from the center of the outer channel in the block in kilohertz and where f is greater than 37.5 kHz.

3.5.2. Test Setup

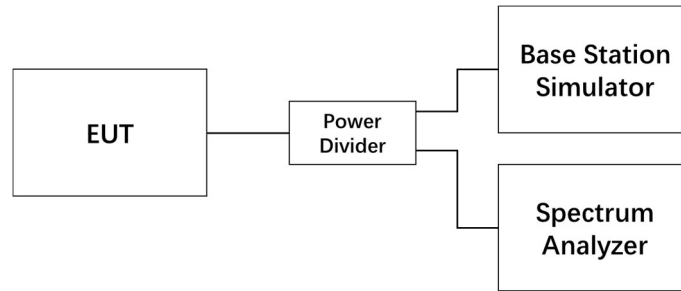

3.5.3. Test Procedures

- 1) The measurement procedure follows ANSI C63.26-2015, clause 5.7.
- 2) The RF output of EUT, BS simulator and spectrum analyzer is connected via a power divider.
- 3) EUT is configured to transmit continuously at fully power while the compliance measurement is performed.
- 4) The span in Spectrum analyzer shall be from 30MHz to 10 times the operating frequency in GHz, with an appropriate resolution bandwidth, video bandwidth, sweep time and detector type.
- 5) Check if some unwanted emission happens, and if amplitude of unwanted emission is higher than the limit.
- 6) The result in worse case will be recorded.

3.5.4. Test Result

Test Engineer	Xu Dongxu	Test Date	2020.08.23
Temperature	21.8°C	Relative Humidity	49.1%
Pressure	101.6kPa	Test Sample Selected	No.1

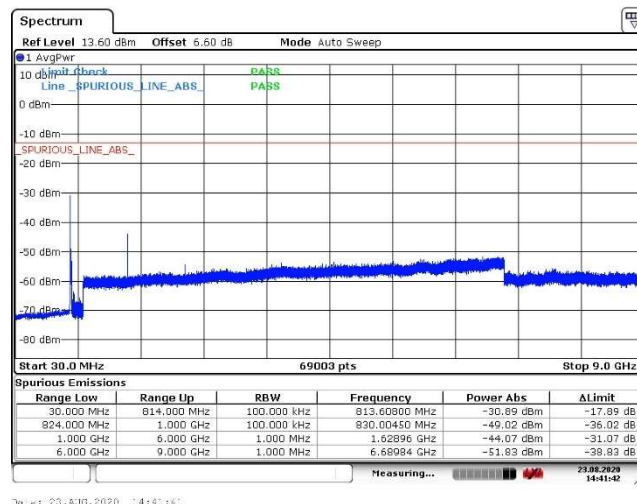

3.5.5. Uncertainty

$$U_{lab}=1.48\text{dB} (k=2)$$

3.6 Field Strength of Spurious Radiation

3.6.1. Limit

FCC 47 CFR Part 90 Subpart S - §90.691

For any frequency removed from the EA licensee's frequency block greater than 37.5 kHz, the power of any emission shall be attenuated below the transmitter power (P) in watts by at least $43 + 10\text{Log}_{10}(P)$ decibels or 80 decibels, whichever is the lesser attenuation, where f is the frequency removed from the center of the outer channel in the block in kilohertz and where f is greater than 37.5 kHz.

3.6.2. Test Setup

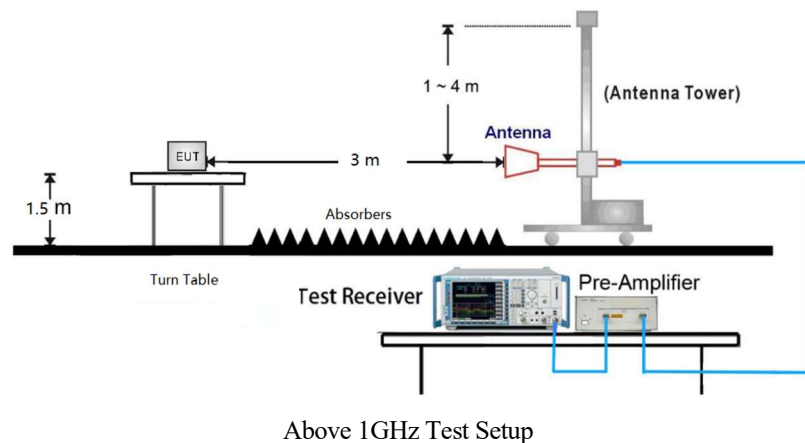
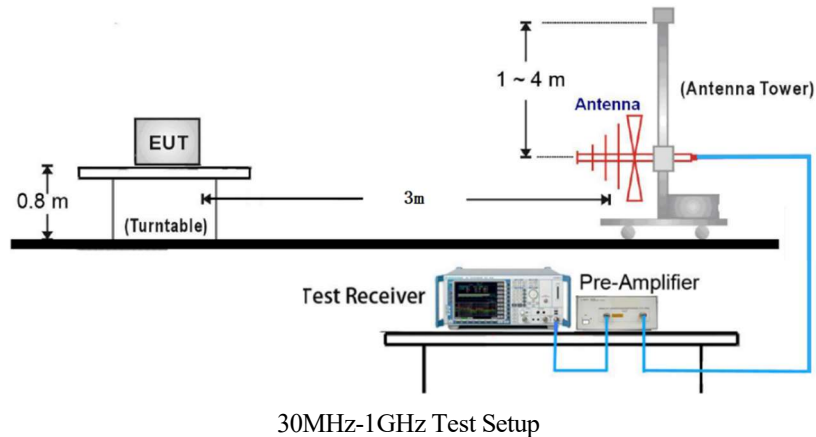

3.6.3. Test Procedures

- 1) The measurement procedure follows ANSI C63.26-2015, clause 5.5.2.5 and 5.5.3.
- 2) Pre-scan is performed to determine the general EUT radiated emissions characteristics and, when necessary, the EUT-to-measurement antenna orientation that produces the maximum emission amplitude.
- 3) Use the substitution method to measure the spurious emissions:
 - (a) Place the EUT in the center of the turntable. The antenna of EUT shall be positioned to produce the worst-case emission at the fundamental operating frequency;
 - (b) Each emission under consideration shall be evaluated:
 - i) Raise and lower the measurement antenna to enable detection of the maximum emission amplitude relative to measurement antenna height.
 - ii) Rotate the EUT through 360° to determine the maximum emission level relative to the axial position.
 - iii) Return the turntable to the azimuth where the highest emission amplitude level was

- observed.
- iv) Vary the measurement antenna height again through 1 m to 4 m again to find the height associated with the maximum emission amplitude.
 - v) Record the measured emission amplitude level and frequency using the appropriate RBW.
- (c) Repeat step (b) for each emission frequency with the measurement antenna oriented in both the horizontal and vertical polarizations to determine the orientation that gives the maximum emissions amplitude.
 - (d) Set-up the substitution measurement with the reference point of the substitution antenna located as near as possible to where the center of the EUT radiating element was located during the initial EUT measurement
 - (e) Connect a signal generator to the substitution antenna. Set the signal generator to the frequency where emissions are detected, and set an output power level such that the radiated signal can be detected by the measurement instrument, with sufficient dynamic range relative to the noise floor.
 - (f) For each emission that was detected and measured in the initial test [in step (b) and step (c)].
 - (g) Repeat step (f) with the measurement antenna oriented in the opposite polarization.
 - (h) Calculate the emission power in dBm referenced to a half-wave dipole using the following equation: $P_e = P_s(\text{dBm}) - \text{cable loss (dB)} + \text{antenna gain (dBd)}$
where
 P_e = equivalent emission power in dBm
 P_s = source (signal generator) power in dBm
 - (i) Correct the antenna gain of the substitution antenna if necessary, to reference the emission power to a half-wave dipole. When using measurement antennas with the gain specified in dBi, the equivalent dipole-referenced gain can be determined from: $\text{gain (dBd)} = \text{gain (dBi)} - 2.15 \text{ dB}$. If necessary, the antenna gain can be calculated from calibrated antenna factor information

3.6.4. Test Result

Test Engineer	Gao Yanan	Test Date	2020.8.28
Temperature	23.4°C	Relative Humidity	54.7%
Pressure	103.6kPa	Test Sample Selected	No.2

Frequency (MHz)	Generator Level (dBm)	Cable Loss (dB)	Gain (dBi)	Level (dBm)	Limit (dBm)	Margin (dB)	Height (cm)	Pol	Azimuth (deg)
87.650000	-61.85	0.33	-0.5	-62.68	-13.00	49.68	100.0	V	90.0
2727.500000	-58.97	1.62	8.99	-51.60	-13.00	38.60	200.0	H	0.0
3276.080000	-52.04	1.88	9.01	-44.91	-13.00	31.91	100.0	H	1.0
4929.591000	-54.11	2.28	9.81	-46.58	-13.00	33.58	100.0	H	1.0
8721.825000	-48.76	2.93	11.49	-40.20	-13.00	27.20	200.0	V	254.0
9737.200000	-47.52	3.14	11.91	-38.75	-13.00	25.75	100.0	H	270.0

3.6.5. Uncertainty

Frequency (MHz)	U_{lab}	k
Below 1GHz	3.24	2
1GHz - 18GHz	3.40	2

3.7 Band Edge

3.7.1. Limit

FCC 47 CFR Part 90 Subpart S - §90.691

For any frequency removed from the EA licensee's frequency block by up to and including 37.5 kHz, the power of any emission shall be attenuated below the transmitter power (P) in watts by at least $116 \text{Log}_{10}(f/6.1)$ decibels or $50 + 10 \text{Log}_{10}(P)$ decibels or 80 decibels, whichever is the lesser attenuation, where f is the frequency removed from the center of the outer channel in the block in kilohertz and where f is greater than 12.5 kHz.

For any frequency removed from the EA licensee's frequency block greater than 37.5 kHz, the power of any emission shall be attenuated below the transmitter power (P) in watts by at least $43 + 10\text{Log}_{10}(P)$ decibels or 80 decibels, whichever is the lesser attenuation, where f is the frequency removed from the center of the outer channel in the block in kilohertz and where f is greater than 37.5 kHz.

3.7.2. Test Setup

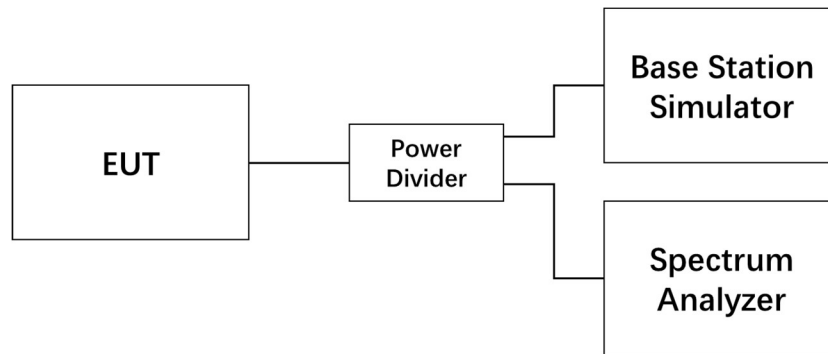

3.7.3. Test Procedures

- 1) The measurement procedure follows ANSI C63.26-2015, clause 5.7.3.
- 2) The RF output of EUT, BS simulator and spectrum analyzer are connected via a power divider.
- 3) EUT is configured to transmit continuously at fully power while the compliance measurement is performed.
- 4) Set the spectrum analyzer center frequency to the block, band, or channel edge frequency.
- 5) Set the span wide enough to capture the fundamental emission closest to the band edge, and to include all modulation products that spill into the immediately adjacent frequency band.
- 6) Set the number of points in sweep $\geq 2 \times \text{span} / \text{RBW}$. And Sweep time should be auto.

3.7.4. Test Result

Test Engineer	Xu Dongxu	Test Date	2020.08.23
Temperature	21.8°C	Relative Humidity	49.1%
Pressure	101.6kPa	Test Sample Selected	No.1

Frequency (MHz)	Channel No.	BW (MHz)	RB Size	RB Offset	Band Edges Plot
					QPSK
814.7	26697	1.4	1	0	Fig.1
			6	0	Fig.2
1	5		Fig.3		
6	0		Fig.4		
815.5	26705	3	1	0	Fig.5
			15	0	Fig.6
1	14		Fig.7		
15	0		Fig.8		
816.5	26715	5	1	0	Fig.9
			25	0	Fig.10
1	24		Fig.11		
25	0		Fig.12		
819.0	26740	10	1	0	Fig.13
			50	0	Fig.14
			1	49	Fig.15
50	0		Fig.16		

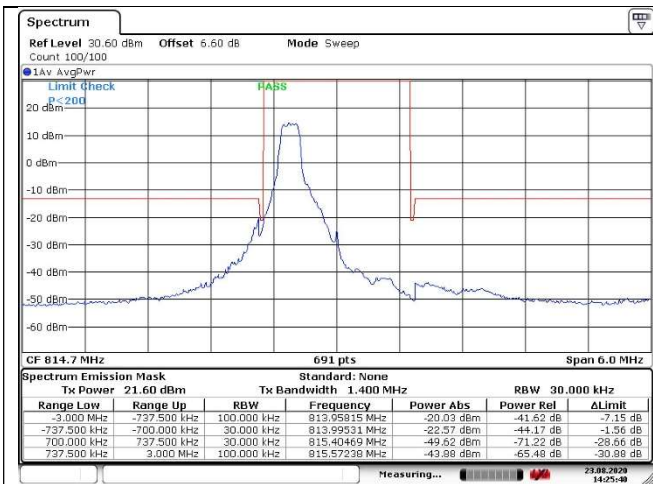
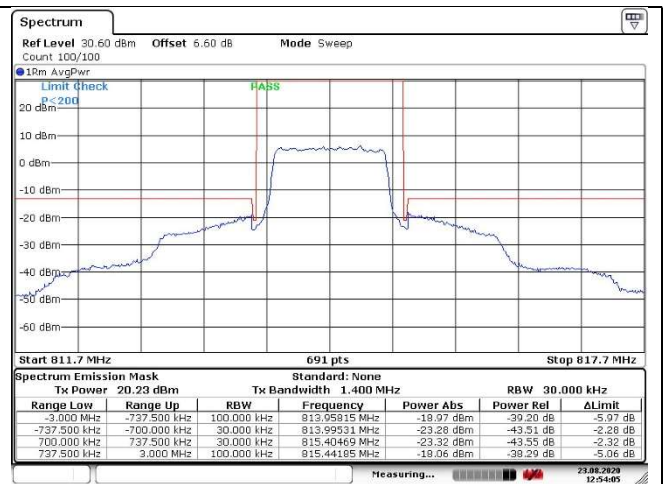
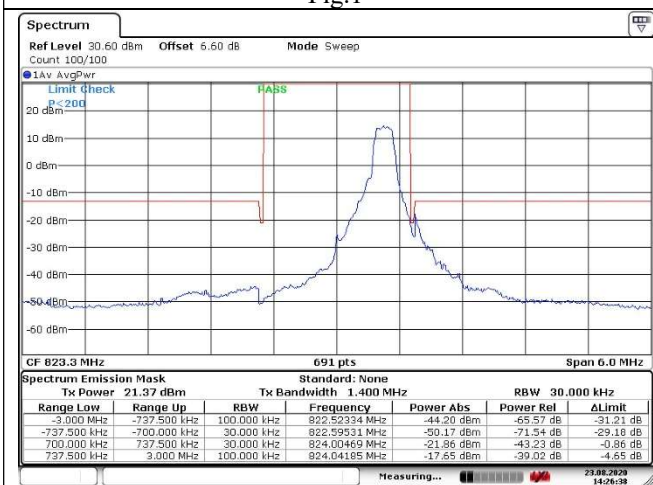
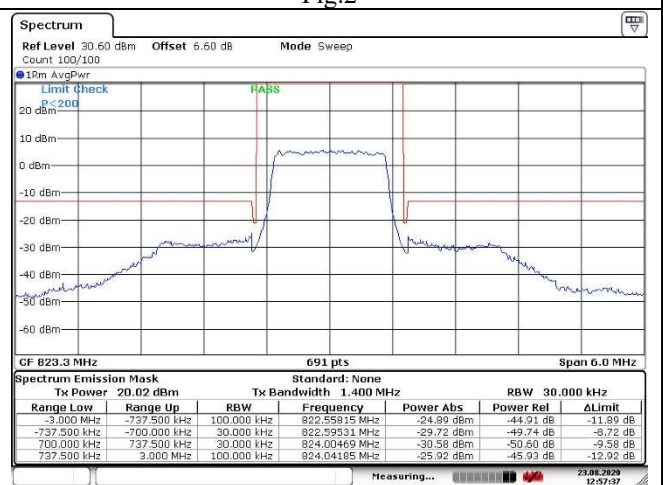
Fig.1

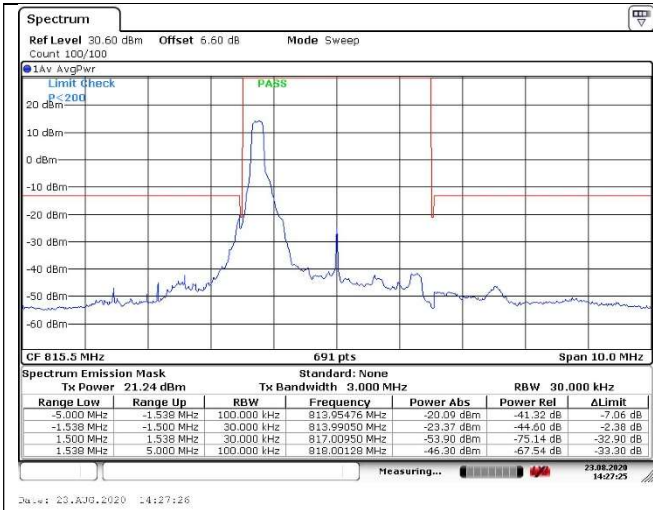
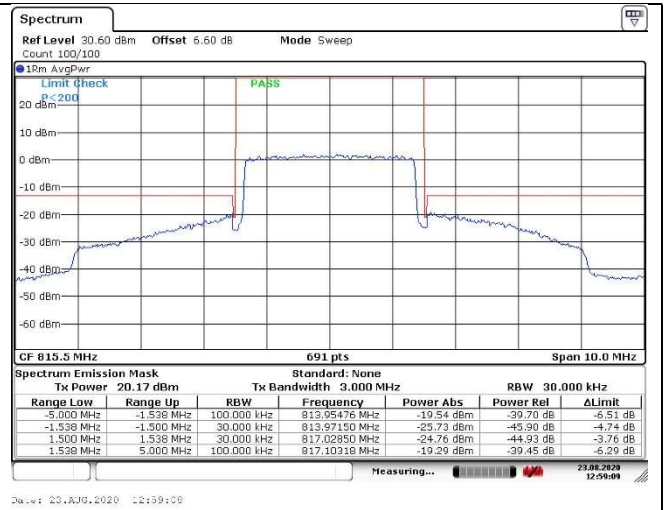
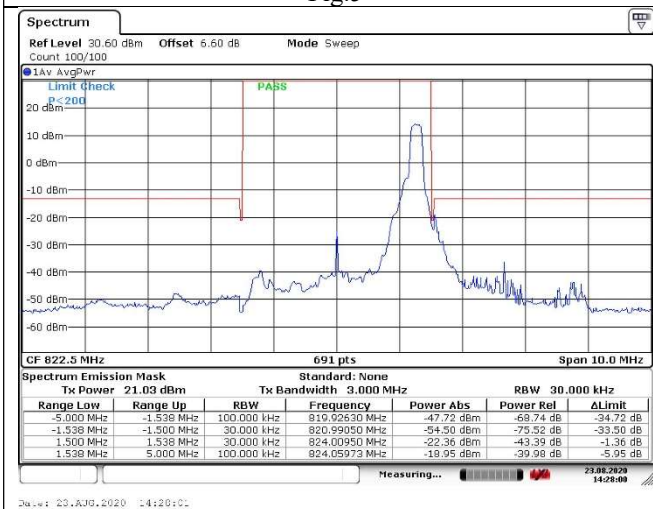
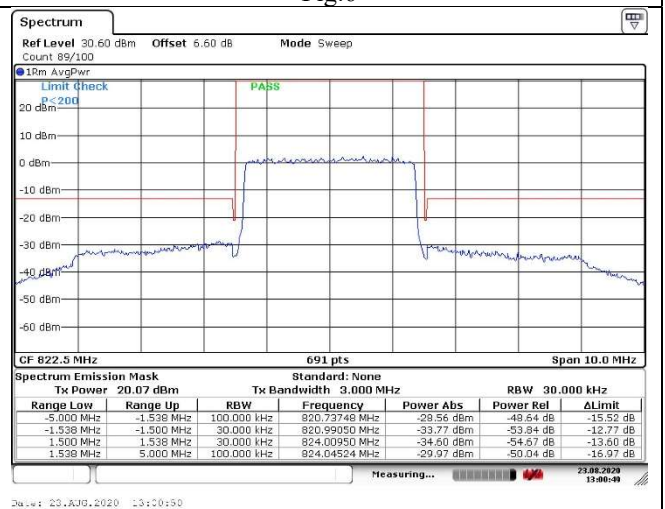
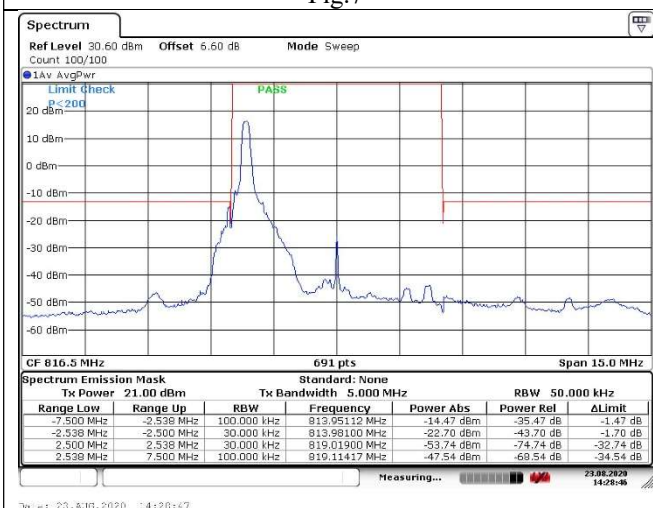
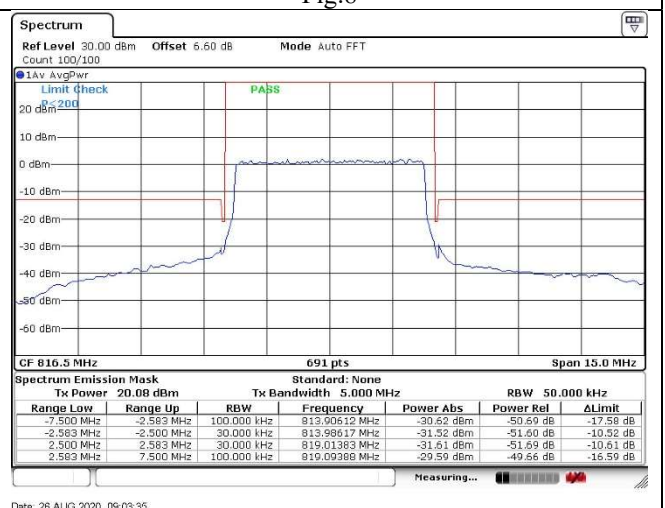
Fig.2

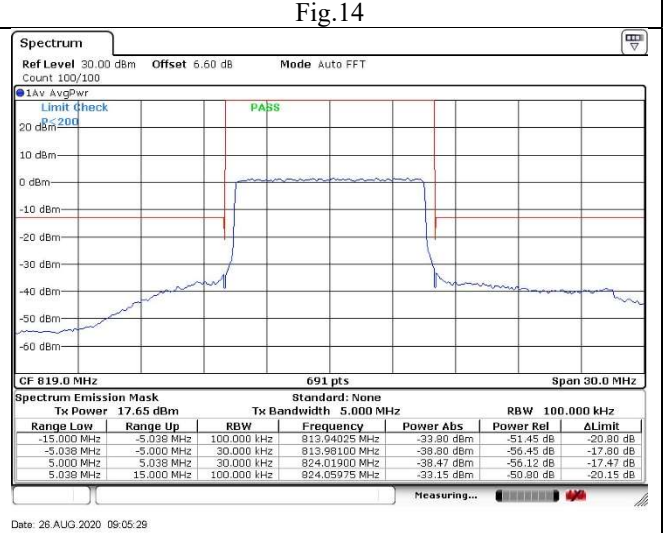
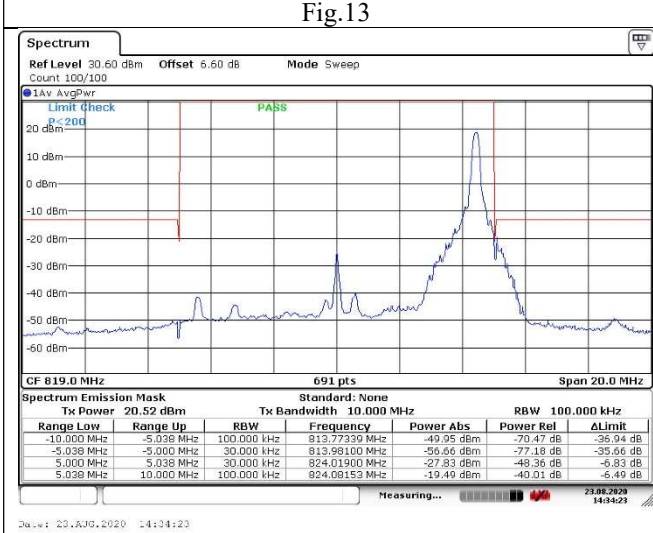
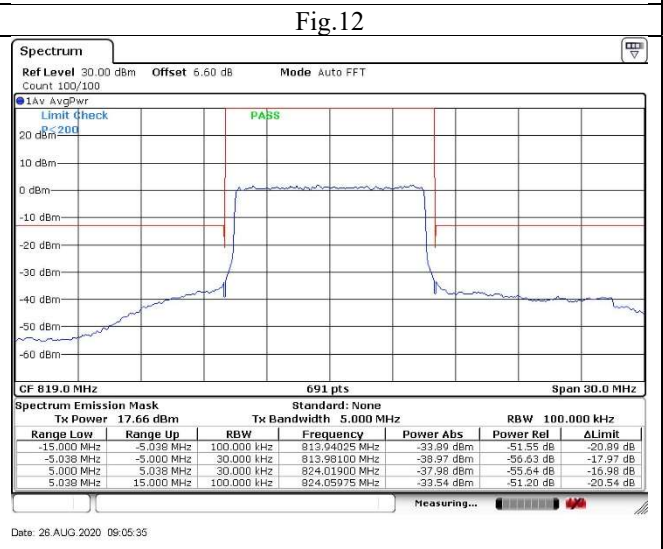
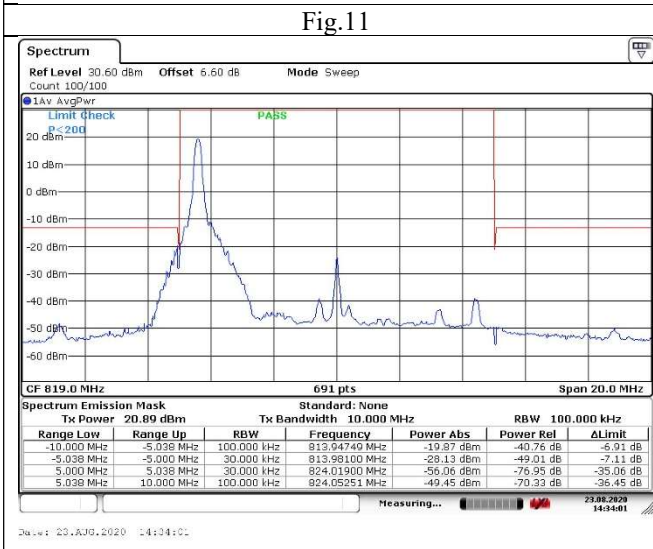
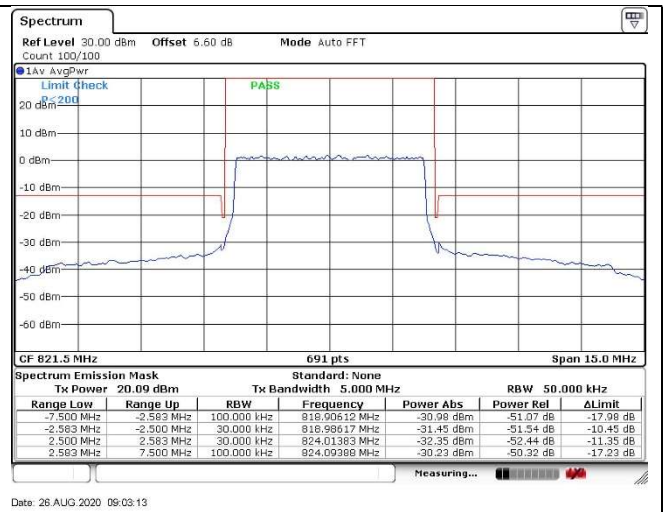
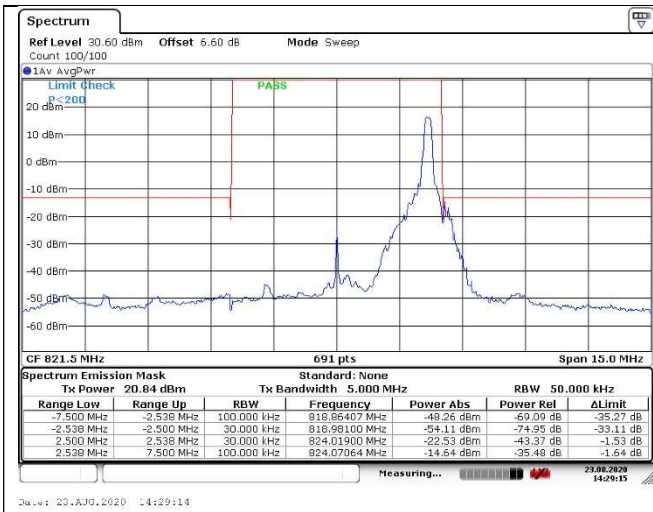
Fig.3

Fig.4

Fig.5

Fig.6

Fig.7

Fig.8

Fig.9

Fig.10



3.7.5. Uncertainty

$$U_{lab}=1.48\text{dB} (k=2)$$

3.8 Frequency Stability

3.8.1. Limit

FCC 47 CFR Part 90 Subpart S - §90.213

Frequency Range (MHz)	Fixed and Base Stations	Mobile Stations	
		Over 2 watts output Power	2 watts or less output Power
809 ~ 824	1.5ppm	2.5ppm	2.5ppm

3.8.2. Test Setup

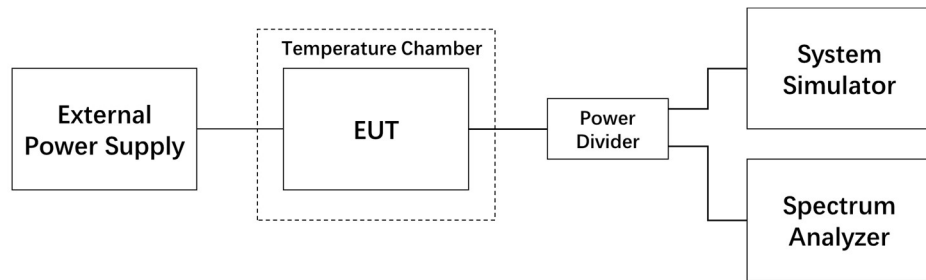

3.8.3. Test Procedures

- 1) The measurement procedure follows ANSI C63.26-2015, clause 5.6.3.
- 2) Frequency Stability over variations in temperature:
 - a) The EUT can power on and work in rated supply voltage via an external power supply.
 - b) The EUT is configured to transmit RF power via a communication test set.
 - c) The EUT is placed in temperature chamber.
 - d) Measure the result of frequency error at 10°C intervals of temperature from -10°C to +55°C.
- 3) Frequency stability when varying supply voltage
 - a) The EUT is placed in a temperature chamber. The temperature in chamber is set to +20°C.
 - b) The EUT is configured to transmit RF power via a communication test set.
 - c) Measure the result of frequency error in Low voltage and high voltage mode.

3.8.4. Test Result

Test Engineer	Xu Dongxu	Test Date	2020.09.10
Temperature	21.9°C	Relative Humidity	47.8%
Pressure	102.1kPa	Test Sample Selected	No.1

1) Frequency Stability when varying temperature:

Temperature(°C)	Voltage	Test Result (ppm) @ Low Channel			
		1.4M	3M	5M	10M
-20	NV	0.091	0.082	-0.095	0.017
-10	NV	0.002	0.070	-0.007	-0.036
0	NV	0.092	-0.073	-0.084	0.042
+10	NV	0.041	-0.015	0.076	0.018
+20	NV	0.000	0.000	0.000	0.000
+30	NV	0.060	0.085	0.009	-0.047
+40	NV	-0.095	0.001	-0.054	-0.036
+50	NV	-0.073	0.063	-0.095	-0.076

Temperature(°C)	Voltage	Test Result (ppm) @ High Channel			
		1.4M	3M	5M	10M
-20	NV	-0.056	0.031	-0.059	0.081
-10	NV	0.047	0.099	-0.057	-0.046
0	NV	-0.022	0.039	-0.086	-0.009
+10	NV	-0.036	0.069	-0.092	-0.096
+20	NV	0.000	0.000	0.000	0.000
+30	NV	0.055	-0.019	-0.062	-0.080
+40	NV	0.023	0.094	-0.018	-0.042
+50	NV	0.013	0.022	0.090	-0.080

2) Frequency stability when varying supply voltage:

Temperature(°C)	Voltage	Test Result (ppm) @ Low Channel			
		1.4M	3M	5M	10M
+20	LV	-0.097	0.002	-0.024	0.010
+20	HV	-0.095	0.054	0.097	0.046

Temperature(°C)	Voltage	Test Result (ppm) @ High Channel			
		1.4M	3M	5M	10M
+20	LV	-0.030	0.089	-0.054	0.002
+20	HV	-0.065	-0.050	0.097	-0.042

3.8.5. Uncertainty

Frequency (MHz)	U_{lab}	k
816.5	71.27Hz	2
821.5	71.61Hz	2

4 Test Instruments

Description	Model Name	S/N	Manufacturer	Next Cal Date
Spectrum Analyzer	FSV40	101403	R&S	2021/1/1
Three-way Power Supply	E3646A	MY43007301	Agilent	2021/1/1
Base Station Simulator	CMW500	115895	R&S	2021/1/1
Power Divider	87302C	MY44300481	Agilent	2021/7/14
Temperature Chamber	HTLH-015/40	JT1906018	Shang Hai Jing Tian	2021/7/2
EMI TEST RECERVER	ESR26	101320	R&S	2020/12/28
Double Ridged Broadband Horn Antenna	HF907	100096	R&S	2021/3/17
Hybrid antenna	VULB9163	01266	SCHWARZBECK	2021/7/3
Double Ridged Broadband Horn Antenna	BBHA 9120D	1276	SCHWARZBECK	2021/3/17
Pre-amplifier	PE15A1009	V00140120181115 E822	Pasternack Enterprises	2021/1/1
Pre-amplifier	8849B	3008A02589	Agilent	2021/3/17
Signal Generator	E8257D	MY46520023	Agilent	2021/1/1
10m Semi Anechoic Chamber	SAC10	--	TDK	2022/12/24
Shielding Room for RF test	SR#2	--	TDK	2024/9/17
Digital Display Temperature and Humidity Recorder	TM320	15082	DICKSON	2021/5/8
Aneroid Barometer	DYM3	868	Shanghai Boji	2022/5/5

--- End of Test Report ---