

# WiFi Tri-Band Antenna

## Flexible Antenna Product Specification

Rev 2.0

Oct. 2022

Part No :  
63081000002

## **CONTENTS**

- 1. SCOPE**
- 2. PRODUCT DESCRIPTION**
- 3. GENERAL SPECIFICATION**
- 4. ANTENNA PERFORMANCE**
- 5. MECHANICAL SPECIFICATION**
- 6. ENVIRONMENTAL SPECIFICATION**

### **Revision History**

## 1.0 Scope

This Product Specification covers the mechanical, electrical and environmental performances specification for Tri-band WIFI 2.4G/5G/6G Flexible Antenna.

## 2.0 Product Description

### 2.1 Product name and Part Number

Product Name : Tri-band WIFI Flexible Antenna

Product Number : 630810000002

### 2.2 Description

Part of 630810000002 is a dipole and low profile flexible antenna for 2400~2500/5150~5850/5925~7125MHz band application.

It's made from Poly-flexible material, has a size form 46.5mm x 12.5mm x 0.15mm and has double-sided adhesive for "peel and stick" easy mounting. It was designed primarily for use with WIFI 5/6/6e modules and devices that require high efficiency and peak gain to deliver best in class throughput for access points, terminals, and routers.

### 2.3 Features

- 2400~2500/5150~5850/5925~7125MHz, Linear polarization
- Flex size 46.5 x 12.5 x 0.15mm (not contain thickness of solder area)
- U.FL / I-PEX MHF 1 compatible connector
- Cable OD0.81mm, standard length of cable as 150mm
- RoHS Compliant

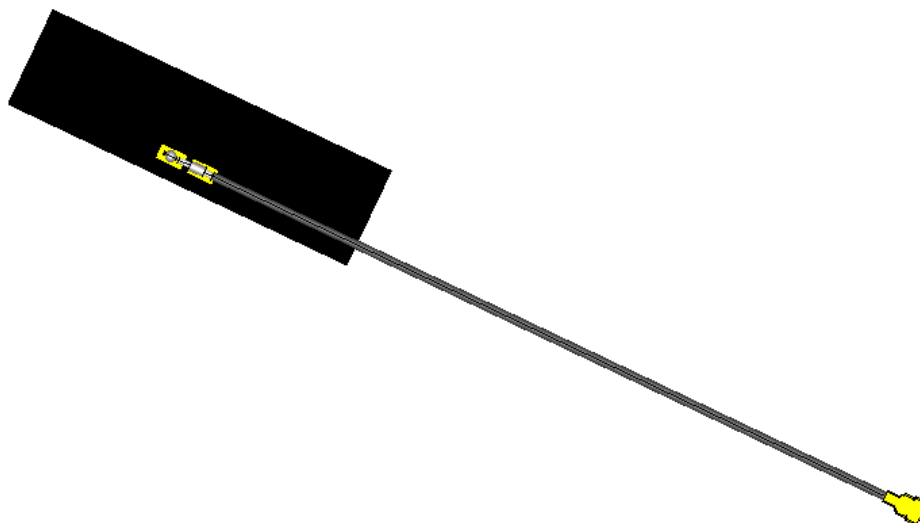

630810000002 Tri-band WIFI Flexible Antenna Module 3D View

## 2.4 Product Structure Information

630810000002

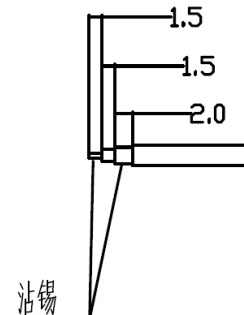
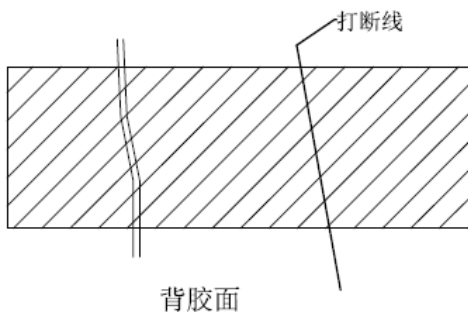
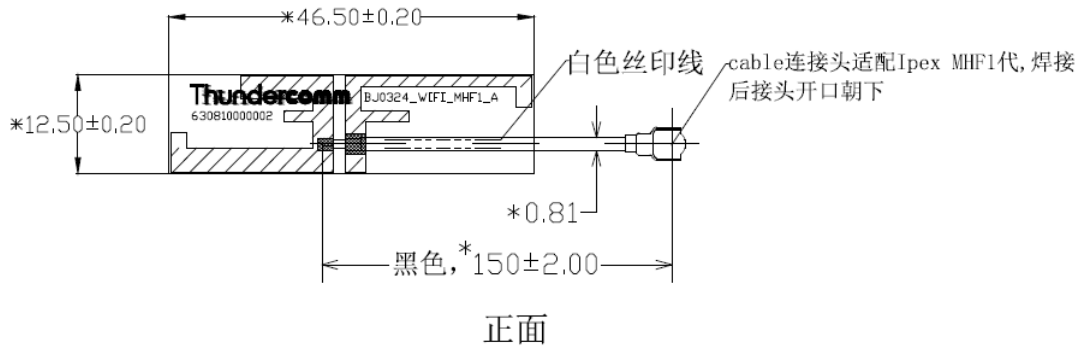

注释:

1. 不明尺寸参考图档
2. 材质: 参考图档
3. 焊点整洁, 高度不超过1.4mm
4. 零件标记: 按指定位置
5. 需通过HAITONG品质部门要求FPC的各项测试, ;盐水喷雾测试要求48H后产品表面无氧化现象
6. 尺寸要求:
  - 6.1 ST尺寸: 测量最小量为500中选取的任意35个产品的尺寸做CPK分析
  - 6.2 \*尺寸为重点管控尺寸
7. 首批物品: 随机挑选5pcs做全尺寸测量, 报告及物品专递HAITONG品质部
8. 任何用料上的修改必须通过HT工程部门书面同意
9. 产品符合RoHS/HF/REACH的要求
10. 油墨: 亚光黑色

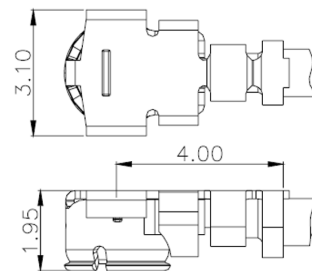

2	G. 1. 22. L. 0068	BJ0324_WB_MHF1_Cable	1	
1	G. 1. 11. L. 0163	BJ0324_WIFI_MHF1_FPC	1	
ITEM	PART NAME	DESCRIPTION	Q'TY	REMARK

### 3.0 General Specification

Product name	WiFi Tri-band Flexible Antenna		
Part number	630810000002		
Frequency	2400-2500 MHz	5150-5850 MHz	5925~7125 MHz
Polarization	Linear		
Operating with matching	-40°C to 80°C		
Storage with matching	-40°C to 80°C		
RF Power	2.0 Watts		
Impedance with matching	50 Ohms		
Antenna type	Dipole		
Connector type	U.FL / I-PEX MHF 1 (Compatible)		
Cable diameter	Ø0.81mm		
Cable Length	150mm		

### 4.0 Antenna Performance

#### 4.1 RF Test Conditions

All measurements are done of the antenna mounted on a polyfoam material block of 1.0cm thickness with VNA Agilent E5071C and Over-The-Air (OTA) chamber. All measurements in this document are done with a cable length of 150mm.

#### 4.2 Antenna Performance

Description	Equipment	Performance (150mm)		
Frequency Range	VNA E5071C	2400-2500 MHz	5150-5850 MHz	5925~7125 MHz
Return Loss	VNA E5071C	<-18 dB	<-10 dB	<-6 dB
Peak Gain (Max)	OTA Chamber	2.5 dBi	2.6 dBi	2.6 dBi
Average Total Efficiency. (dB)	OTA Chamber	-2.2	-3.0	-2.9
Input Impedance	VNA E5071C	50 ohms		

Note that the above antenna performance is measured under a similar free-space condition. When implement into the system, the frequency resonant might be off-tune due to the loading of surrounding components especially metal plane. This off-tune can be compensated through matching. The radiation pattern will change due to the surround components as well.

### 4.3 Antenna Gain of Bands

Band	Frequency Range	Peak Gain (dBi)
WiFi 2.4G	2400~2500MHz	2.5
WiFi 5.0G	5150~5250MHz	2.1
	5250~5350MHz	2
	5350~5450MHz	2.6
	5450~5725MHz	2.6
	5725~5850MHz	2.2
	5850~5900MHz	2.3
WiFi 6.0G	5925~6125MHz	2.3
	6125~6325MHz	2.6
	6325~6525MHz	2.4
	6525~6725MHz	2.1
	6725~6925MHz	1.5
	6925~7125MHz	1.2

### 4.4 Return Loss Plot

All measurements in this document are done with cable length of 150mm.

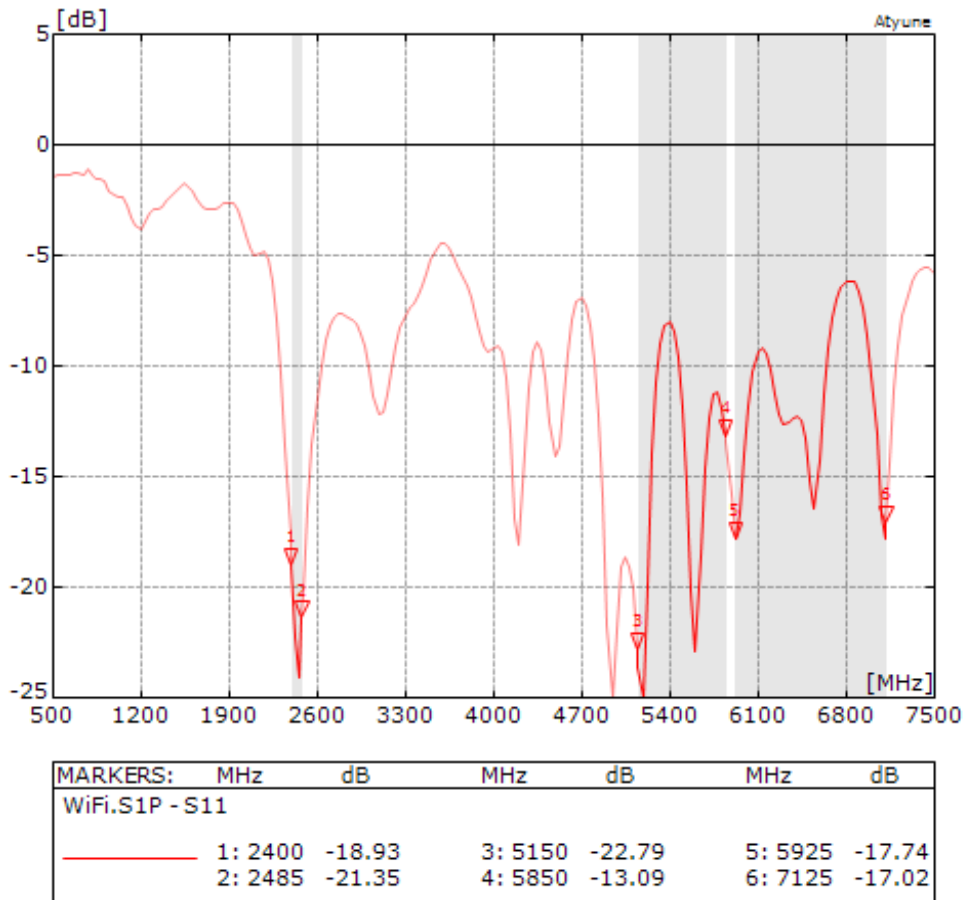

Figure 4.3.1 Return Loss of Antenna In Free Space

### 4.5 Efficiency Plot

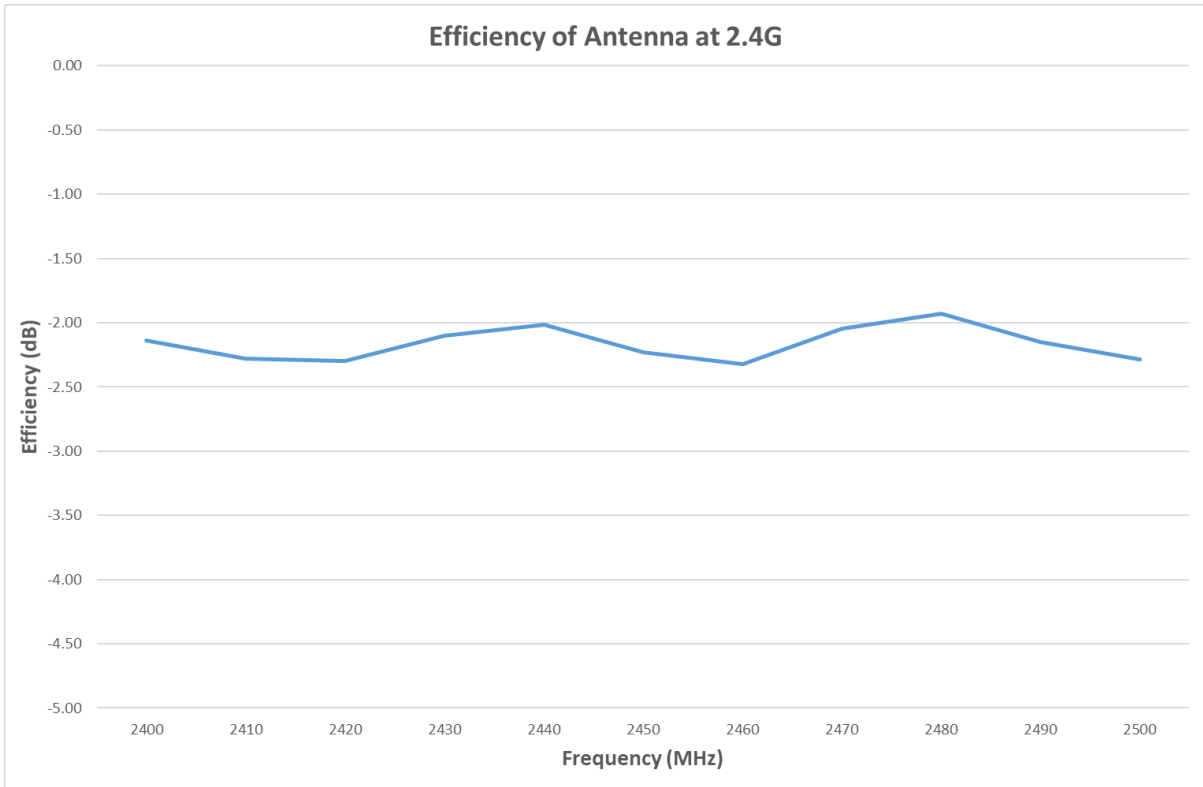

Figure 4.4.1 Efficiency of Antenna at 2400-2500MHz In Free Space

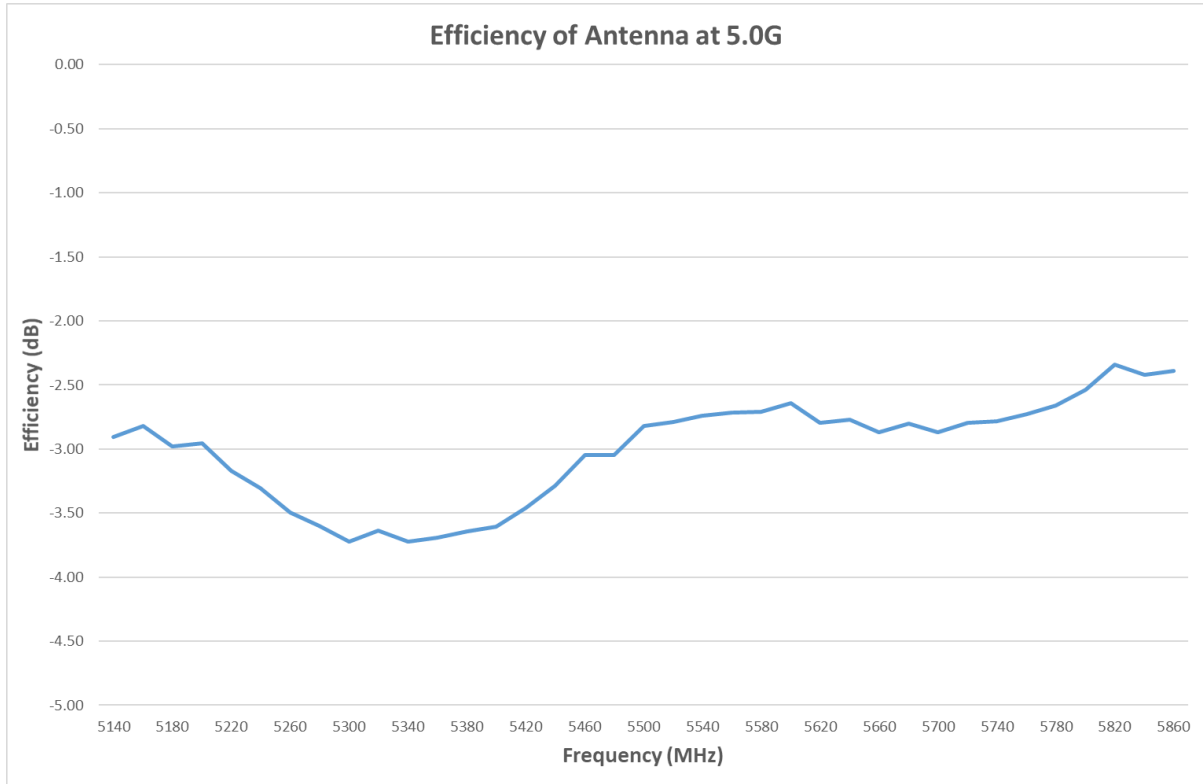

Figure 4.4.2 Efficiency of Antenna at 5150-5850MHz In Free Space

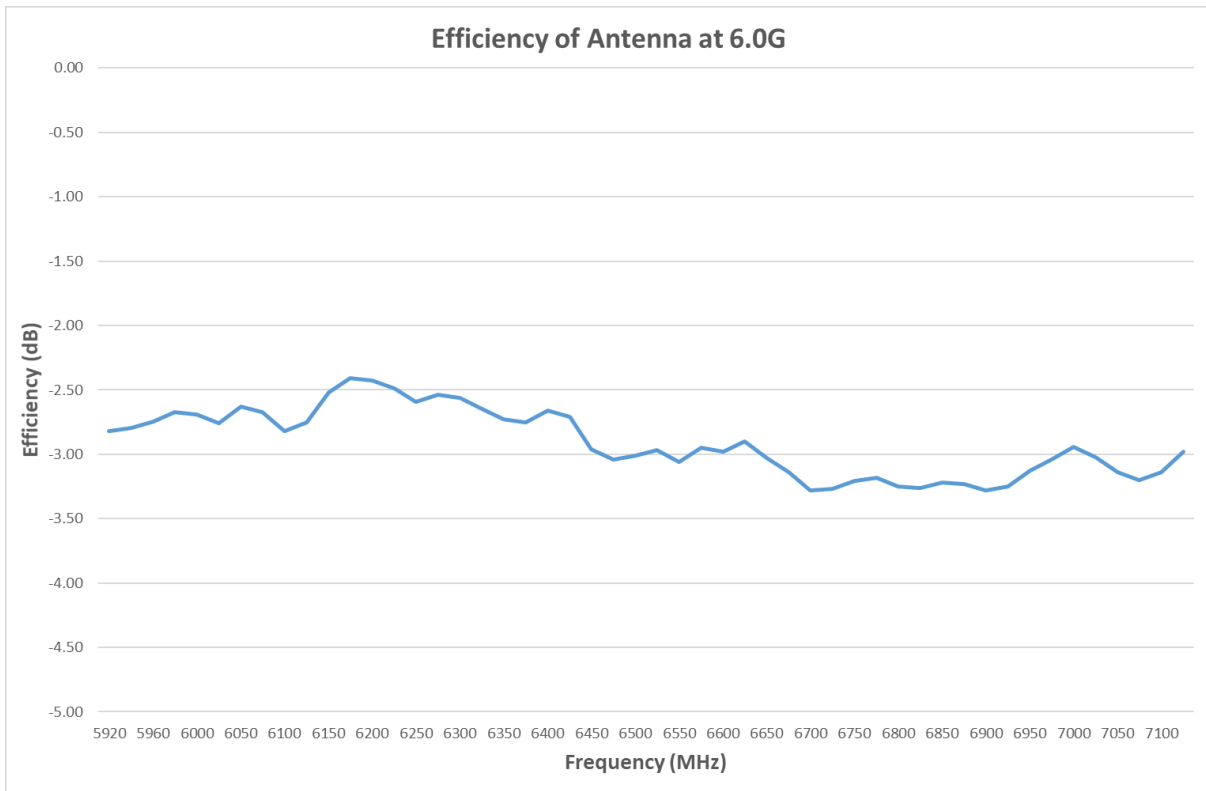
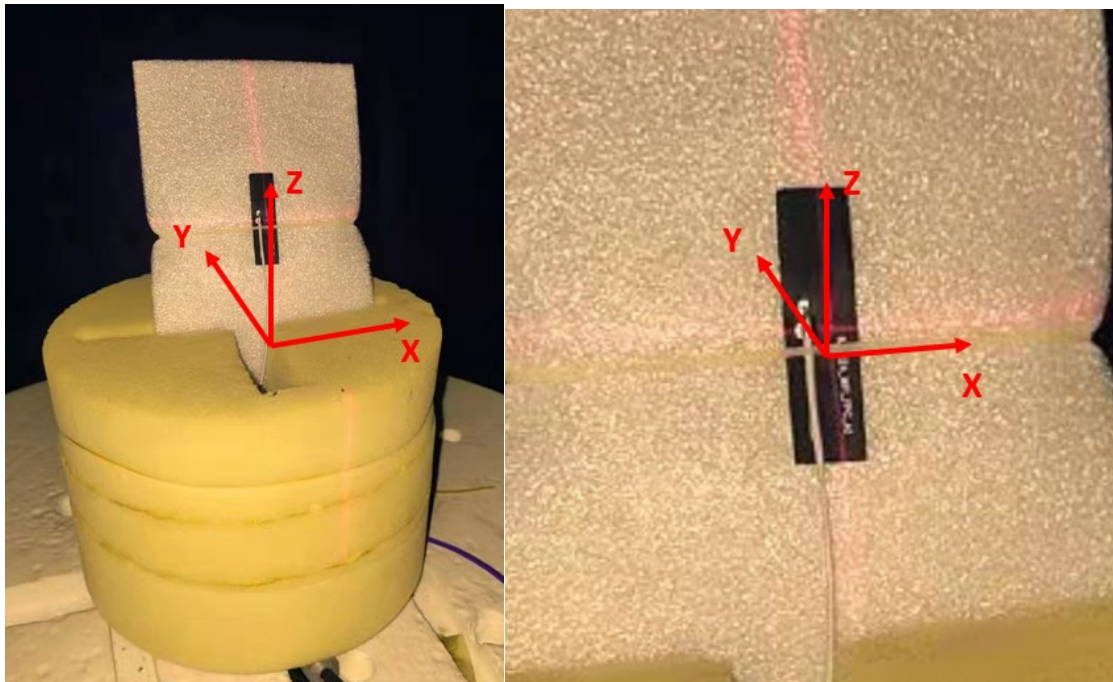

Figure 4.4.3 Efficiency of Antenna at 5920-7125MHz In Free Space

## 4.6 2D Radiation Pattern

Test condition:





**Y-Z 2440MHz**

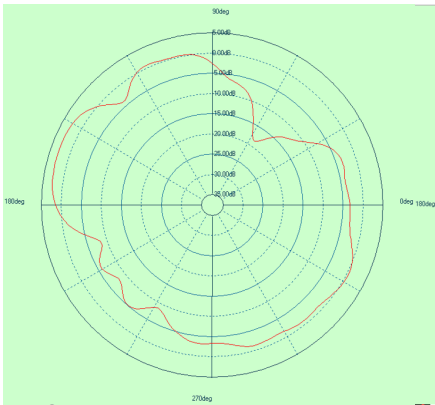

**X-Z 2440MHz**

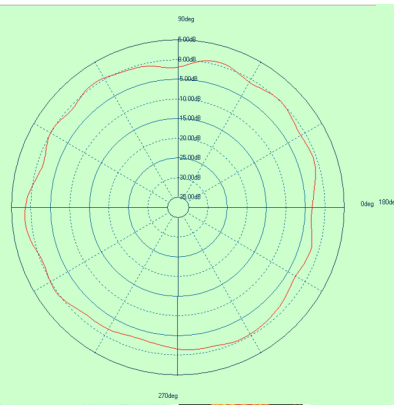

**X-Y 2440MHz**

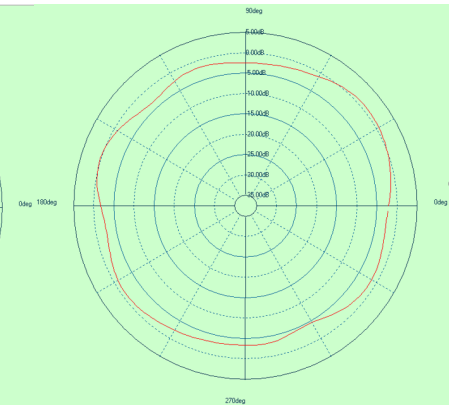

**Y-Z 5150MHz**

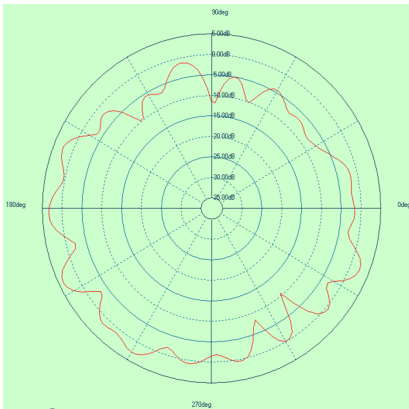

**X-Z 5150MHz**

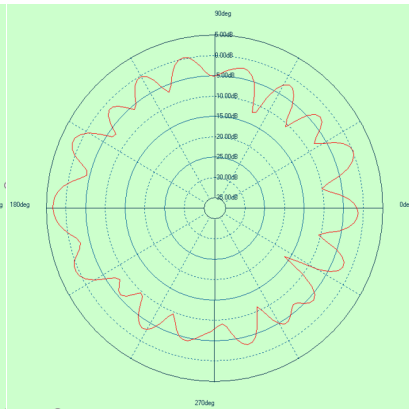

**X-Y 5150MHz**

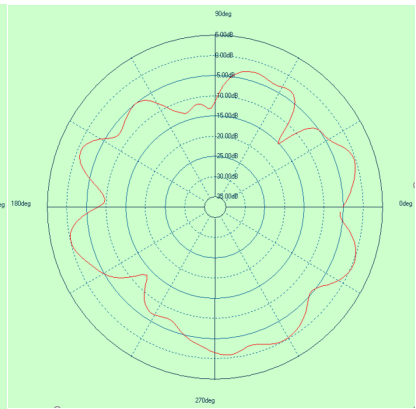

**Y-Z 5500MHz**

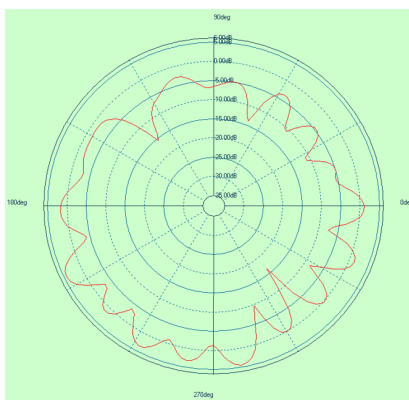

**X-Z 5500MHz**

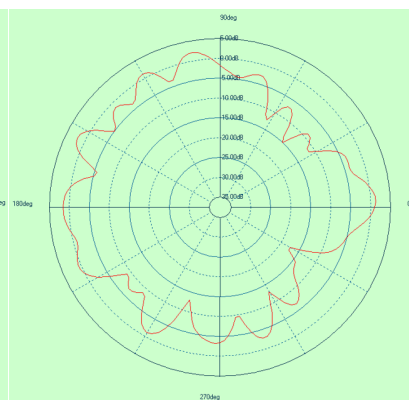

**X-Y 5500MHz**

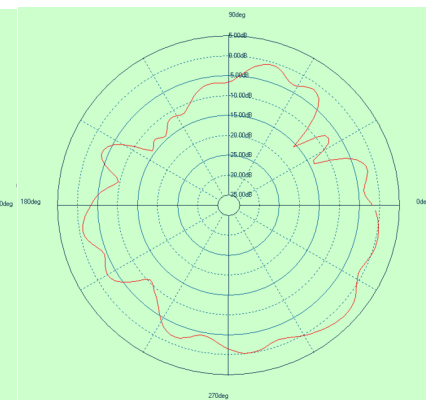

**Y-Z 5850MHz**

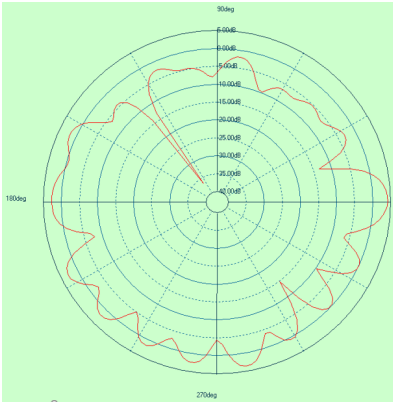

**X-Z 5850MHz**

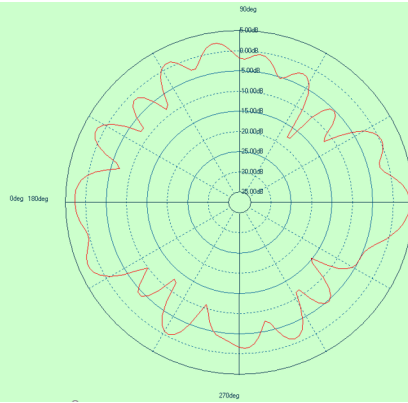

**X-Y 5850MHz**

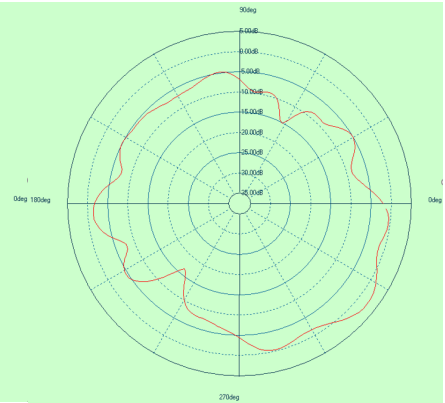

**Y-Z 6000MHz**

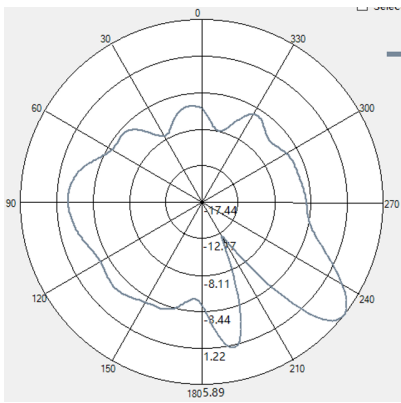

**X-Z 6000MHz**

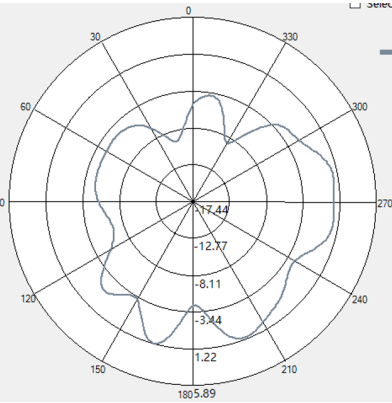

**X-Y 6000MHz**

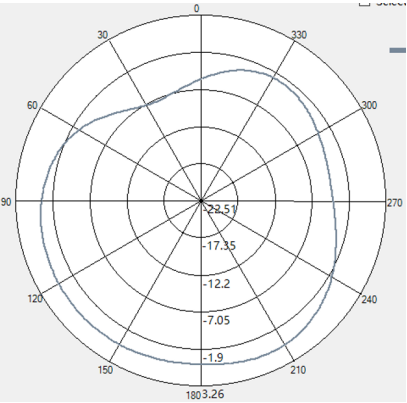

**Y-Z 6500MHz**

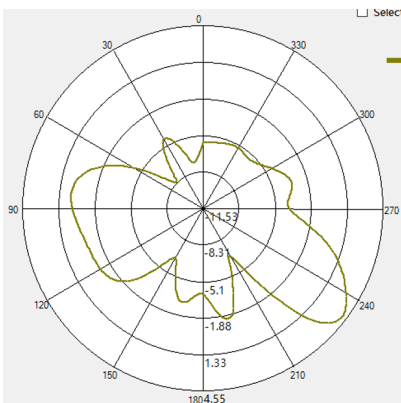

**X-Z 6500MHz**

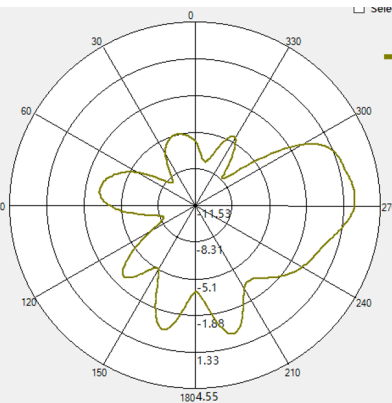

**X-Y 6500MHz**

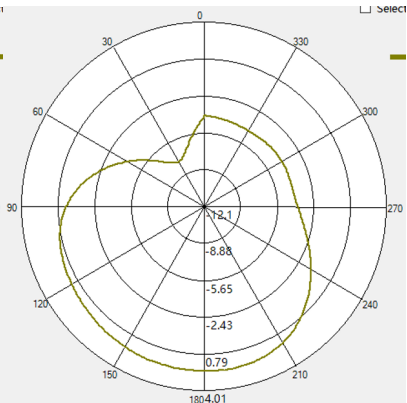

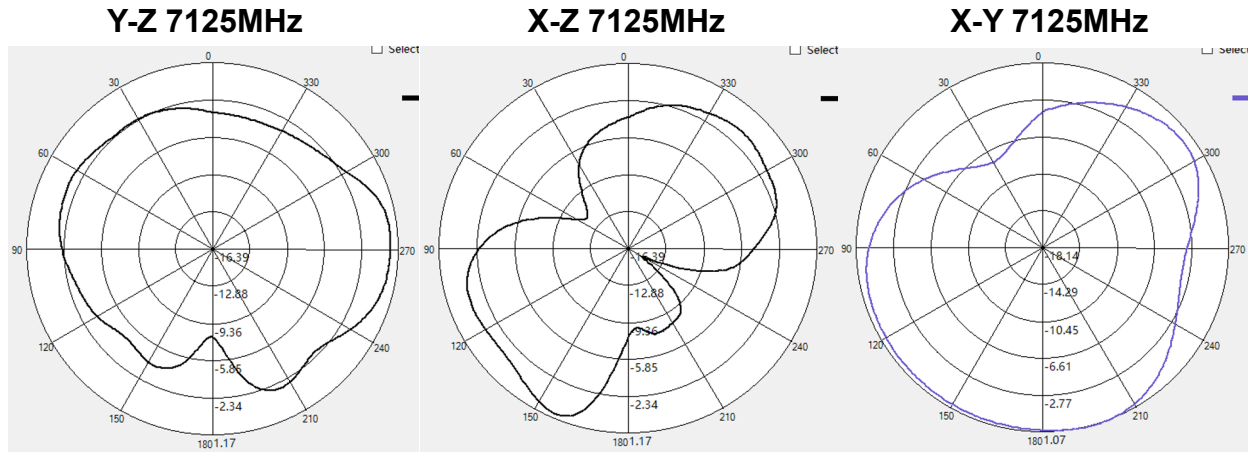

### 4.7 3D Radiation Pattern

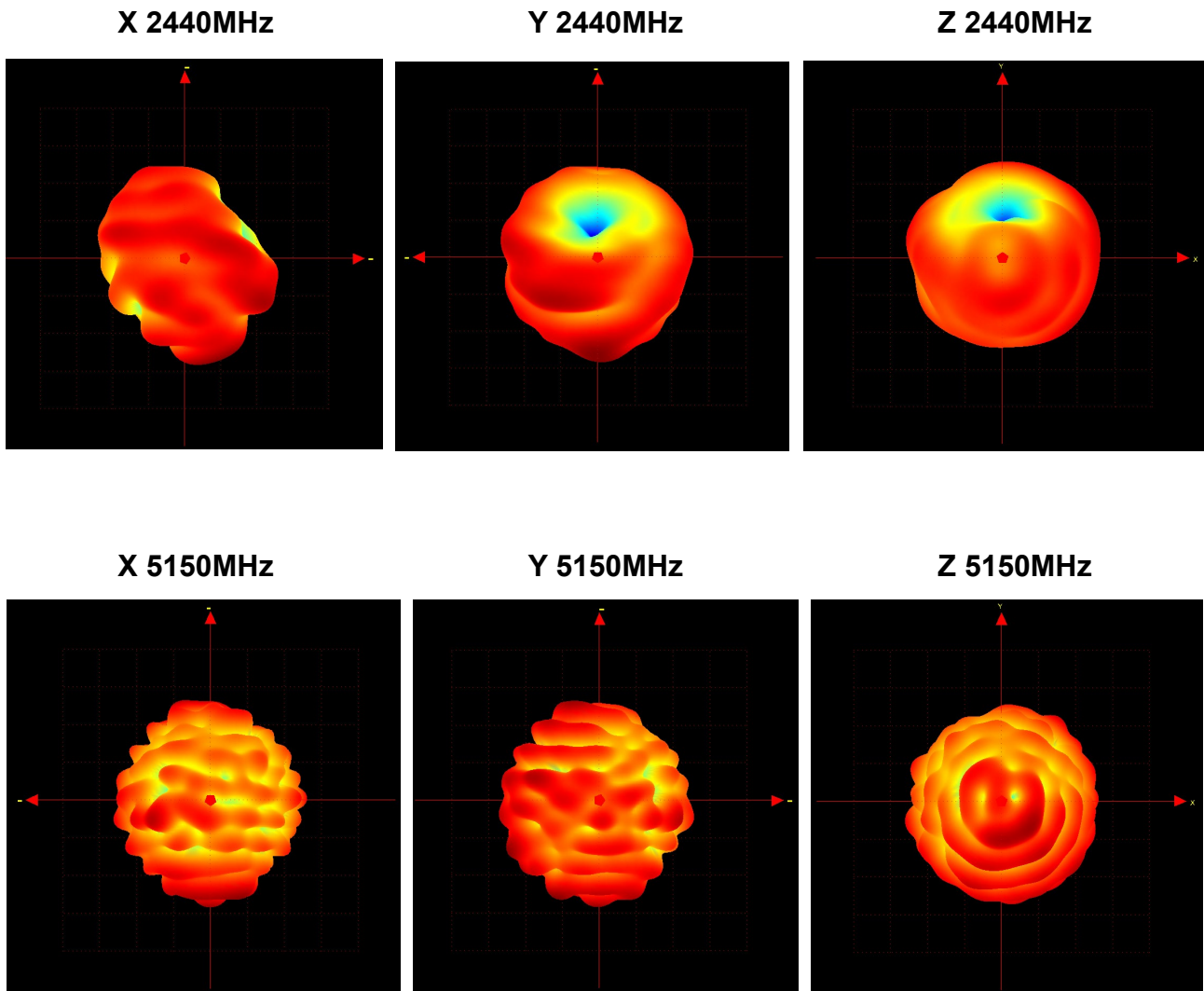

**X 5500MHz**

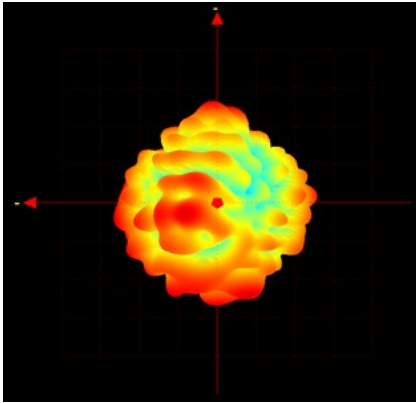

**Y 5500MHz**

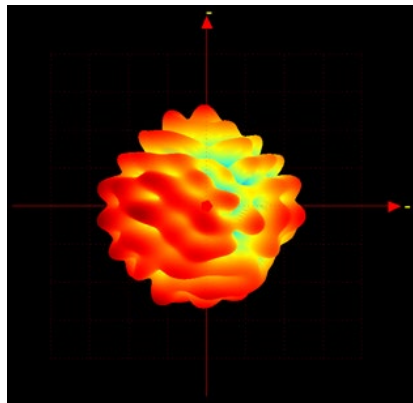

**Z 5500MHz**

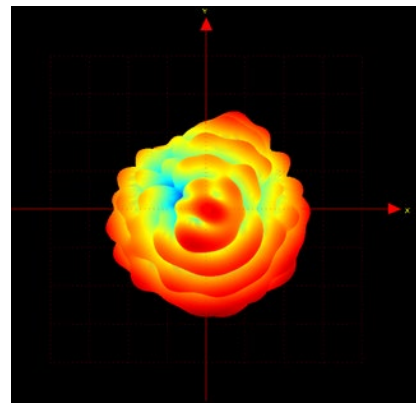

**X 5850MHz**

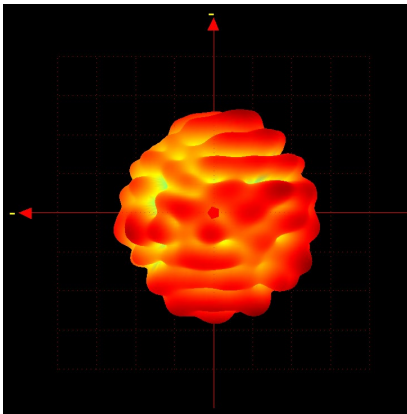

**Y 5850MHz**

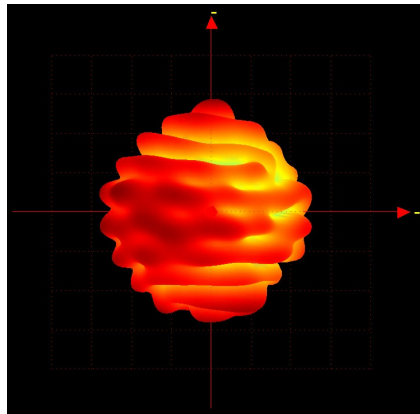

**Z 5850MHz**

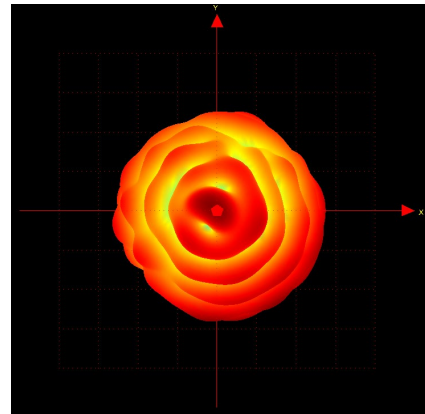

**X 6000MHz**

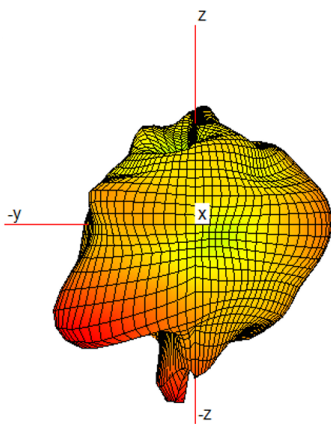

**Y 6000MHz**

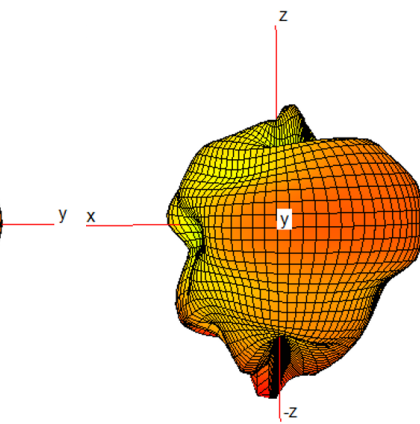

**Z 6000MHz**

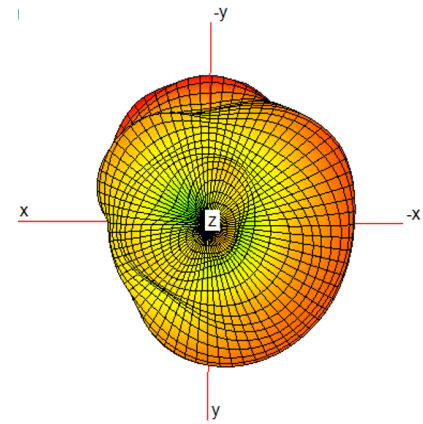

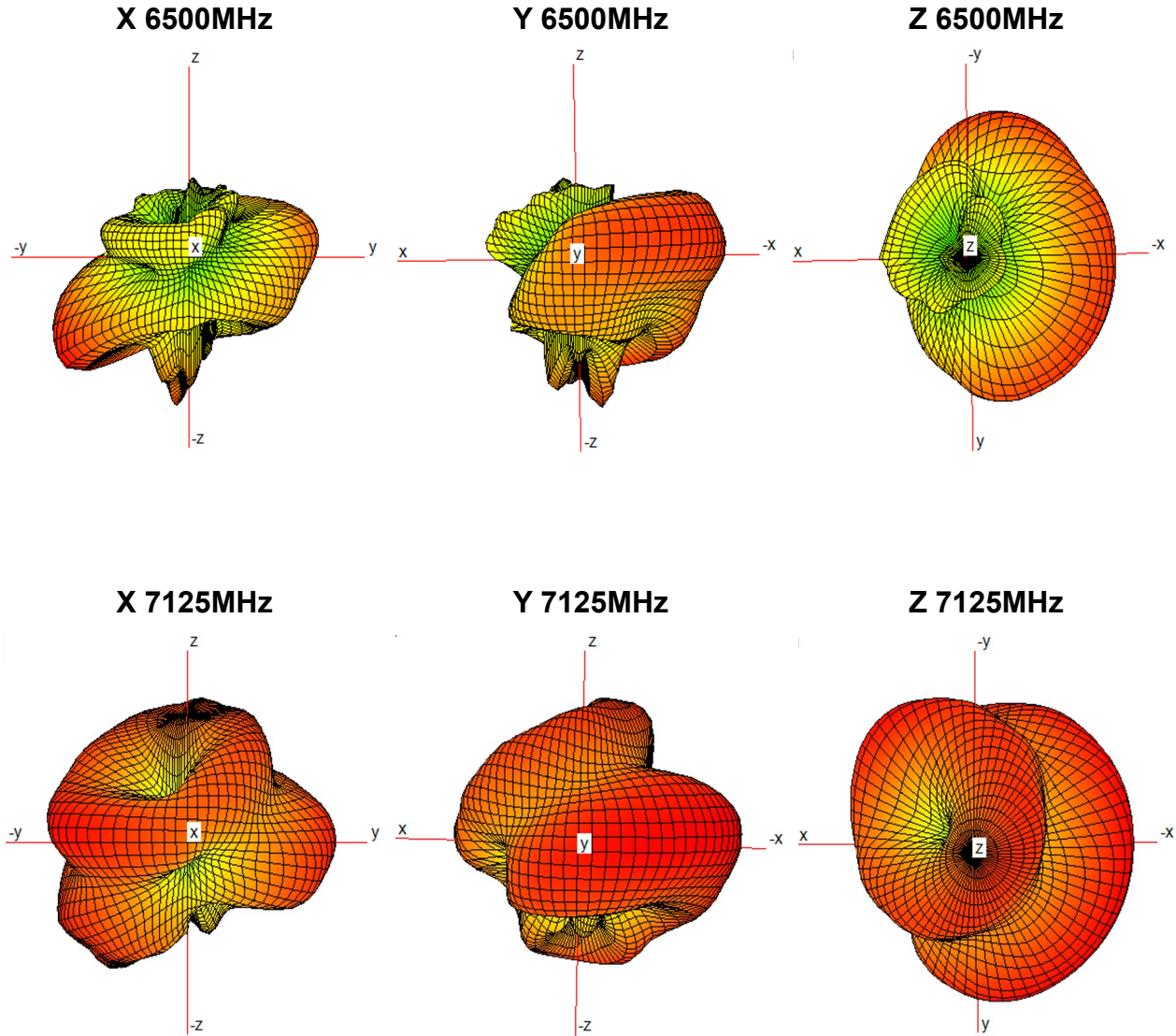

## 5.0 Mechanical Specification

Description	Test Condition	Test Result
Pull Test	1, Test machine: Max intelligent load tester 2, Stick the flex antenna on a plastic board, pull cable in axial direction.	Pull force >8N
Un-mating force (connector)	Solder the receptacle connector to the test board ,then place the board and plug on push-on/pull-off machine, and repeat mating and un-mating 30 cycles at a speed 25±3mm/min. along the mating axis.	Un-mating force : 0.5 kgf min

## 6.0 Environmental Specification

Description	Specification
Temperature /Humidity cycling	<ol style="list-style-type: none"> <li>1. The device under test is kept for 30 Min. in an environment with a temperature of -40 °C.</li> <li>2. Kept for 4 Hours in an environment with a temperature of 85 degrees and a relative humidity of 95%.</li> <li>3. Kept for 2 Hours in an environment with a temperature of 125 degrees and a relative humidity of 95%.</li> <li>4. The cycle is repeated until a total of 40 cycles have been completed. Hereafter the conditions are stabilized at room temperature. Transfer temperature 8°C per min.</li> <li>5. Parts should meet RF spec before and after test.</li> <li>6. No cosmetic problem (No soldering problem; No adhesion problem of glue.)</li> </ol>
Temperature Shock	<ol style="list-style-type: none"> <li>1. The device under test at -40 °C ⇔ 80 °C by 100 cycles, Dwell of 30 Min., transition time between Dwell 30 Sec. (~ 61 Min. / cycle) and each item should be measured after exposing them in normal temperature and humidity for 24 Hour.</li> <li>2. Parts should meet RF spec before and after test.</li> <li>3. No cosmetic problem (No soldering problem; No adhesion problem of glue.)</li> </ol>
High Temperature	<ol style="list-style-type: none"> <li>1. Temperature:80°C, time:48 hours</li> <li>2. There is no substantial obstruction to air flow across and around the samples, and the samples are not touching each other.</li> <li>3. Parts should meet RF spec before and after test.</li> <li>4. No cosmetic problem (No soldering problem; No adhesion problem of glue.)</li> </ol>
Salt mist test	<ol style="list-style-type: none"> <li>1. The device under test is exposed to a spray of a 5% (by volume) resolution of NACL in water for 2 hours. Thereafter the device under test is left for 1 week in room temperature at a relative humidity of 95%. The cycle is repeated until a total of 2 cycles have been completed. Here after the conditions are stabilized at room temperature.</li> <li>2. Parts should meet RF spec before and after test.</li> <li>3. No visible corrosion. Discoloration accept.</li> </ol>

## Revision History

<b>Revision</b>	<b>Date</b>	<b>Description</b>
1.0	March.22 2022	First Release
2.0	October.10 2022	Update with Antenna Gain of Bands



Empowering Every IoT Device with Our Technology

6540 Lusk Blvd. Suite C166 San Diego CA 92121

[service@thundercomm.com](mailto:service@thundercomm.com)

+86-10-62662686

[www.thundercomm.com](http://www.thundercomm.com)

Copyright Thundercomm Technology Co., Ltd. 2019 All right reserved