

F-C01

User Manual



v1.0

In the Box

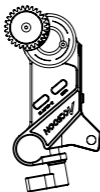

Motor * 1



Controller * 1



Motor Mount Adapter * 1



Controller Mount Adapter * 1



15mm Rod * 1

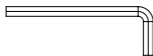

3/16" Allen Key* 1

In the Box

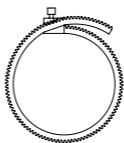

Focus Gear Ring (0.8 Mod; Supports up to 4.1" diameter lens) * 1

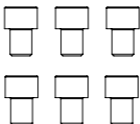

1/4"-20 x 5/16" Socket Head Cap Screw * 6



Motor Power Cable * 1

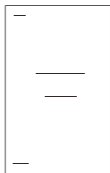

User Manual, Warranty Card * 1

Contents

■ Instructions · English

Product Feature	1
F-C01 Diagram	2
Instruction	6
Functions	11
Specification	13
Warranty	14

Product Features

Equipped with Anti-interference FHSS Technology

0.01s Quick Response, Fast Spinning Support

350ft/100m Control Range

A/B Quick Focus Point Setting

Automatic and Manual Lens Calibration

Support Wired and Wireless Control

Strong Torque in a Compact Design

Switchable Motor Rotation Direction

Equipped with Status OLED Display

Aluminum Alloy and Engineering Plastics Machining

F-C01 Motor

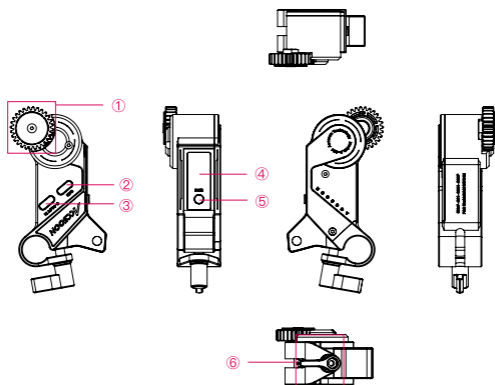

- ① Follow focus gear
- ② Camera-extension interface
- ③ Motor power interface & Controller wired control interface
- ④ OLED display
- ⑤ PAIR button (for wireless pairing with controller)
- ⑥ Hand screw

01 F-C01 Motor OLED Display

1. Wireless/Wired connection status

① **X**: No control signal connection.



② **Signal strength**: The signal strength between the motor and the controller. (Motor is paired with controller)



③ **BUS**: The motor is cable-connected.



2. Route bar

The percentage of current controller rotation route.



3. Calibration status

④ **FREE**: Freshly powered on, calibration not yet completed, and route bar at 0%.



⑤ **IN CAL**: Under calibration.



⑥ **ARMED**: Calibration completed, and current route percentage is shown.



4. Current firmware version of the motor



5. Error codes

When the motor is under stall protection* or other error, the error code will be shown on the OLED.



*Stall protection: Motor Stall refers to a situation where the motor is mechanically or artificially obstructed and cannot rotate. Accsoon F-C01's stall protection technology can prevent and reduce the damage to the motor.



F-C01 Controller

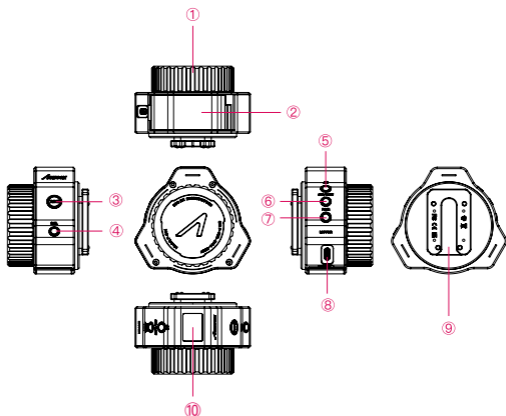

- | | | |
|---|--|--|
| ① 320-degree damping knob | ② Battery box | ③ REC button (for power On/Off) |
| ④ CAL button (for motor automatic/manual calibration) | ⑤ AB button (for activate/deactivate AB points) | ⑥ CW/CCW button (for switching motor rotation direction) |
| ⑦ PAIR button (for wireless pairing with F-C01 motor) | ⑧ Motor interface (for wired connection of motor and controller) | ⑨ Controller quick release adapter |
| ⑩ OLED display | | |

02 F-C01 Controller OLED Display

1. Battery power level

When battery level is below 1%, the battery icon will flash and automatically switch off in 3 to 4 seconds.

**2. Wireless/Wired connection status**

① **X**: The controller is wireless-connected, the controller is not paired with the motor.



② **Signal strength**: The signal strength between controller and motor, the controller is paired with the motor.



③ **BUS**: The controller is cable-connected.

**3. Current motor rotation direction****4. Route bar**

The percentage of current controller rotation route.

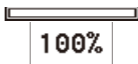
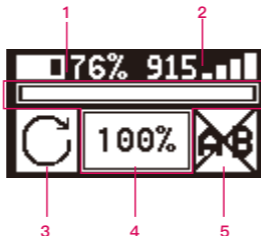
**5. A/B setting status**

Instructions

01 Install focus gear ring and adapter

1. Focus gear ring: Attach the focus gear ring to the lens and tighten it. Ensure the gear ring is installed properly to allow unobstructed motion. (If your lens has its own follow focus ring, please skip this step).

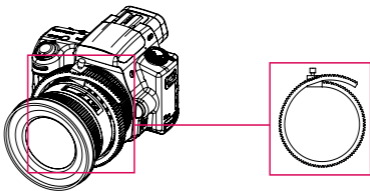

2. Motor mount adapter: Attach the motor mount adapter to the camera cage with screws.

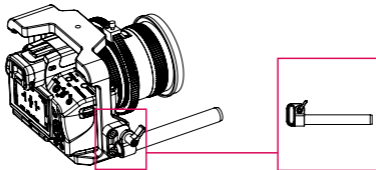

3. Controller mount adapter: If you need to mount the controller to the cage, you can use the screws to attach the adapter to the cage first, and then mount the controller to the adapter.

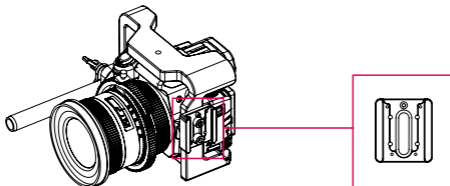

02 Install the F-C01 motor

1. Attach the motor to the motor mount adapter and rod with the hand screw, and then engage the focus gear on the motor with the lens ring.

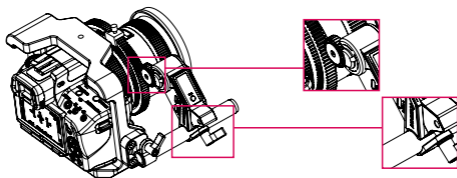

2. When the motor is powered on, the route bar will be at 0% and flashing "FREE" until the calibration is completed.



03 Prepare the F-C01 controller

1. Use NP-FW50 batteries to power the F-C01 controller.
2. Power On/Off via the REC button on the controller.

Power On/Off: Hold the REC button for 3 seconds.

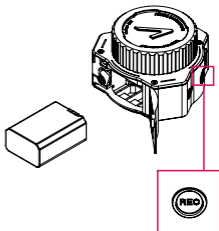

Instructions

04 Wireless pairing

1. F-C01's motor and controller have already been paired before leaving the factory, and are ready to work when powered on.
2. If you need to change to a new motor or controller, please follow the steps below for re-pairing.
 - ① Connect power to the motor and hold the PAIR button on the motor until the wireless icon starts to flash on the motor's OLED screen;

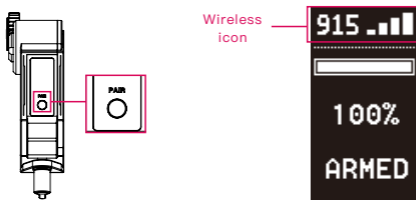

- ② Hold the PAIR button on the controller until the wireless icon starts to flash on the controller's OLED screen;



- ③ F-C01's motor and controller will pair automatically;
 - ④ After the pairing is completed, the OLED screens of the motor and controller will display the strength of the wireless signal at the same time.

05 Lens calibration

After the motor and the controller are paired, a calibration is needed for the motor to find the start point and the end point on the lens.

F-C01 supports both automatic and manual lens calibration. If your camera lens doesn't have mechanical limits, use manual calibration. If it has, use either automatic calibration or manual calibration.

1. Automatic calibration

- ① Hold CAL button on the controller for 2 seconds to enter automatic calibration mode;
- ② The motor will automatically rotate to the "Start Point" and "End Point" to complete the automatic calibration;
- ③ After calibration is completed, the OLED screen of the motor will display "ARMED" and the controller's current route percentage.

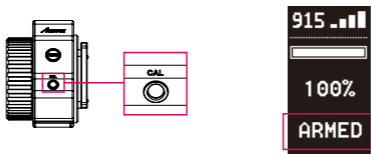

2. Manual calibration

- ① Double click CAL button on the controller to enter manual calibration mode;
- ② Rotate the lens to the start position manually, then press CAL button on the controller to set "Start Point";
- ③ Next rotate the controller manually to the "End Point", press CAL button on the controller to confirm and complete the manual calibration;
- ④ After calibration is completed, the OLED screen of the motor will display "ARMED" and the controller's current route percentage.

Note:

1. After calibration, if: ①the motor direction is changed; or ②the motor is disconnected from the controller, the motor will return to uncalibrated status and need to be recalibrated.
2. If encountering motor stall protection (OLED screen will display error code: ERR01), a reboot is needed.



Instructions

06 Wired control mode

To achieve wired control connection, you need to connect the 5-16.8V IN interface on the motor to the MOTOR interface on the controller with the motor power cable.

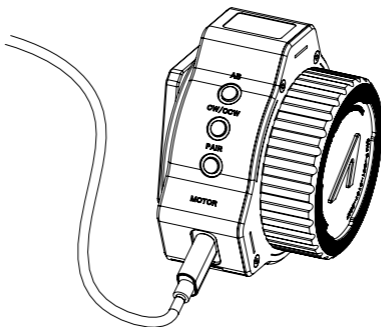
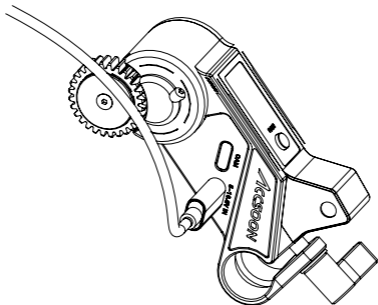

Functions

01 A/B points setting

You can set two different quick focus points which allow rapid focus switching during shooting.

How to set:

Press the AB button on controller to activate/deactivate A/B points.

1. Rotate the controller to the first point and press the AB button to set point A;

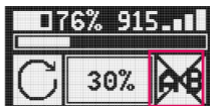

2. Rotate the controller to the second point and Press the AB button to set point B;

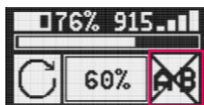

3. Press the AB button again to cancel preset AB points.

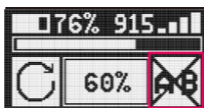

02 Motor rotation direction switching

F-C01's motor can be mounted on either side of the lens, and the user can customize the motor rotation direction as they desired.

Switching method:

Hold the CW/CCW button on the controller for 2 seconds to switch.

Note:

It is recommended that the user switches the direction of rotation before the calibration's completed. If the user wants to change the direction of rotation after calibration, the motor will automatically return to uncalibrated state and need to be recalibrated.

03 Firmware update

You can update F-C01 directly via Accsoon official App – Accsoon Go.

Note:

- ① Before searching for the latest firmware, please confirm that your mobile phone's WiFi can access the Internet so that the App can search and download the latest firmware from the server.
- ② Please ensure your mobile phone's Bluetooth is on (If it is not, when the App is launched, the App will ask for permission to turn it on)

1. Download App

Please download the App – Accsoon Go from Google Play Store or iOS Apple Store.

2. Complete connection

- ① Power the controller, then connect the motor and controller via motor power cable;
- ② Open Accsoon Go, select "F-C01", and then tap "Connect".

3. Firmware update

- ① After the connection is completed, the App will automatically search for the latest firmware and compare it with the current F-C01 firmware. If there is a new firmware available for update, tap "Confirm" to start the update.
- ② If the update completes, the App will prompt "Firmware update succeeded" and the controller and the motor will automatically switch off; if the update fails, the App will prompt "Firmware update failed", please reboot the controller and the motor and try again.

Functions

Note:

- ① Please ensure that the controller's battery level is above 50% during the update.
- ② Please ensure that the controller is connected to the motor during the update.
- ③ Please ensure that no power down occurs during the update.

Specification

	Motor	Controller
Operating Frequency	904.17-915.17MHz	
Operating Current	Static Current: 105mA (@8.4V) Stall Current: 1.5A (@8.4V)	Static Current: 95mA (@8.4V)
Transmitter Power	20dBm	
Max Torque	0.3N·m	
Max Rotation Speed	225RPM	
Max Transmission Range	100m (Outdoors and unobstructed)	
Response Time	10ms (Within communication distance, unobstructed)	
Input Voltage	5~16.8V	7.4V(NP-FW50 battery input)
Output Voltage	5V	8.4V
Material	Aluminum alloy, engineering plastics	
Operation Environment Temperature	-10~40°C	
Dimensions	53.5*104*32mm	79*73*55mm
Weight	100g	110g

Warranty

01 Warranty Period

1. If there is a quality problem that occurs within 15 days after receiving the product, Accsoon will be providing complimentary maintenance or replacement.
2. Accsoon will provide a one-year warranty on the products and a three-month warranty on the accessories and cables. Free maintenance service is available during the warranty period.
3. Please keep the proof of purchase and the user manual in a safe place.

02 Warranty Exclusions

1. Out of warranty (If the proof of purchase is not available, the warranty will be calculated from the date the product is delivered from the factory).
2. Damage caused by use or maintenance is not following the requirements of the product manual.
3. Unauthorized repair, modification or disassembly.
4. Damage caused by force majeure such as fire, flood, lightning strike, etc.

03 Warranty Process

1. Contact your local Accsoon authorized dealers for after-sales service. If there is no local authorized dealers, you can contact our customer service via our email (support@accsoon.com) or website (www.accsoon.com) and get appropriate support.
2. You will get detailed solutions from the authorized dealers or Accsoon.
3. Accsoon reserves the right to review the damaged product.

FCC Caution

This device complies with part 15 of the FCC Rules. Operation is subject to the following two conditions:

- (1) This device may not cause harmful interference, and
- (2) this device must accept any interference received, including interference that may cause undesired operation.

Any Changes or modifications not expressly approved by the party responsible for compliance could void the user's authority to operate the equipment.

Note: This equipment has been tested and found to comply with the limits for a Class B digital device, pursuant to part 15 of the FCC Rules. These limits are designed to provide reasonable protection against harmful interference in a residential installation. This equipment generates uses and can radiate radio frequency energy and, if not installed and used in accordance with the instructions, may cause harmful interference to radio communications. However, there is no guarantee that interference will not occur in a particular installation. If this equipment does cause harmful interference to radio or television reception, which can be determined by turning the equipment off and on, the user is encouraged to try to correct the interference by one or more of the following measures:

- Reorient or relocate the receiving antenna.
- Increase the separation between the equipment and receiver.
- Connect the equipment into an outlet on a circuit different from that to which the receiver is connected.
- Consult the dealer or an experienced radio/TV technician for help.

Contact Us

 **Facebook:** Accsoon

 **Facebook Group:** Accsoon Official User Group

 **Instagram:** accsoontech

 **Youtube Channel:** ACCSOON

 **Email:** Support@accsoon.com

Certificate of Quality

This product is confirmed to meet quality standards and permitted for sale after strict inspection.

QC Inspector: _____



More details about the product please visit www.accsoon.com

This document is subject to change without notice.

Accsoon® is a trademark of Accsoon Technology Co., Ltd.

Copyright© 2022 Accsoon. All rights reserved

