



Prüfbericht-Nr.: <i>Test Report No.:</i>	50257350 001	Auftrags-Nr.: <i>Order No.:</i>	238105923	Seite 1 von 45 <i>Page 1 of 45</i>
Kunden-Referenz-Nr.: <i>Client Reference No.:</i>	N/A	Auftragsdatum: <i>Order date:</i>	29-May-2019	
Auftraggeber: <i>Client:</i>	Asuka Autotronics Inc. 2F, No. 12, Prosperity Rd. II, SBIP, 30078 Hsinchu, Taiwan, R.O.C.			
Prüfgegenstand: <i>Test item:</i>	RF BT Module			
Bezeichnung / Typ-Nr.: <i>Identification / Type No.:</i>	AK-888			
Auftrags-Inhalt: <i>Order content:</i>	FCC Part 15C Test report (BR/EDR)			
Prüfgrundlage: <i>Test specification:</i>	FCC 47CFR Part 15: Subpart C Section 15.247			
Wareneingangsdatum: <i>Date of receipt:</i>	01-Aug-2019			
Prüfmuster-Nr.: <i>Test sample No.:</i>	A000968792-001			
Prüfzeitraum: <i>Testing period:</i>	05-Aug-2019~19-Sep-2019			
Ort der Prüfung: <i>Place of testing:</i>	EMC/RF Laboratory Taipei			
Prüflaboratorium: <i>Testing laboratory:</i>	TUV Rheinland Taiwan Ltd.			
Prüfergebnis*: <i>Test result*:</i>	Pass			
Report date / tested by:		kontrolliert von / reviewed by:		
				
2020-01-14	Mars Y.J. Lin / Project Engineer	2020-01-14	Ryan W.T. Chen / Project Manager	
<i>Datum</i>	<i>Name / Stellung</i>	<i>Datum</i>	<i>Name / Stellung</i>	<i>Unterschrift</i>
<i>Date</i>	<i>Name / Position</i>	<i>Date</i>	<i>Name / Position</i>	<i>Signature</i>
Sonstiges / Other:				
Zustand des Prüfgegenstandes bei Anlieferung: <i>Condition of the test item at delivery:</i>		Prüfmuster vollständig und unbeschädigt <i>Test item complete and undamaged</i>		
* Legende: 1 = sehr gut 2 = gut 3 = befriedigend 4 = ausreichend 5 = mangelhaft P(ass) = entspricht o.g. Prüfgrundlage(n) F(ail) = entspricht nicht o.g. Prüfgrundlage(n) N/A = nicht anwendbar N/T = nicht getestet				
Legend: 1 = very good 2 = good 3 = satisfactory 4 = sufficient 5 = poor P(ass) = passed a.m. test specification(s) F(ail) = failed a.m. test specification(s) N/A = not applicable N/T = not tested				
Dieser Prüfbericht bezieht sich nur auf das o.g. Prüfmuster und darf ohne Genehmigung der Prüfstelle nicht auszugsweise vervielfältigt werden. Dieser Bericht berechtigt nicht zur Verwendung eines Prüfzeichens. <i>This test report only relates to the a. m. test sample. Without permission of the test center this test report is not permitted to be duplicated in extracts. This test report does not entitle to carry any test mark.</i>				

TEST SUMMARY

5.1.1 ANTENNA REQUIREMENT

RESULT: *Passed*

5.1.2 PEAK OUTPUT POWER

RESULT: *Passed*

5.1.3 20dB BANDWIDTH

RESULT: *Passed*

5.1.4 CONDUCTED SPURIOUS EMISSIONS AND FREQUENCY BAND EDGE MEASURED IN 100KHZ BANDWIDTH

RESULT: *Passed*

5.1.5 SPURIOUS EMISSION

RESULT: *Passed*

5.1.6 FREQUENCY SEPARATION

RESULT: *Passed*

5.1.7 NUMBER OF HOPPING FREQUENCY

RESULT: *Passed*

5.1.8 TIME OF OCCUPANCY

RESULT: *Passed*

5.2.1 MAINS CONDUCTED EMISSIONS

RESULT: *Passed*

6.1.1 ELECTROMAGNETIC FIELDS

RESULT: *Passed*

Contents

1.	GENERAL REMARKS	5
1.1	COMPLEMENTARY MATERIALS.....	5
2.	TEST SITES	6
2.1	TEST LABORATORY	ERROR! BOOKMARK NOT DEFINED.
2.2	TEST FACILITY.....	ERROR! BOOKMARK NOT DEFINED.
2.3	LIST OF TEST AND MEASUREMENT INSTRUMENTS.....	7
2.4	TRACEABILITY	8
2.5	CALIBRATION	8
2.6	MEASUREMENT UNCERTAINTY	8
3.	GENERAL PRODUCT INFORMATION.....	9
3.1	PRODUCT FUNCTION AND INTENDED USE	9
3.2	SYSTEM DETAILS AND RATINGS.....	9
3.3	INDEPENDENT OPERATION MODES.....	11
3.4	NOISE GENERATING AND NOISE SUPPRESSING PARTS	11
3.5	SUBMITTED DOCUMENTS.....	11
4.	TEST SET-UP AND OPERATION MODES.....	12
4.1	PRINCIPLE OF CONFIGURATION SELECTION	12
4.2	TEST OPERATION AND TEST SOFTWARE.....	12
4.3	SPECIAL ACCESSORIES AND AUXILIARY EQUIPMENT	13
4.4	COUNTERMEASURES TO ACHIEVE EMC COMPLIANCE.....	13
4.5	TEST SETUP DIAGRAM	13
5.	TEST RESULTS	15
5.1	TRANSMITTER REQUIREMENT & TEST SUITES.....	15
5.1.1	<i>Antenna Requirement</i>	15
5.1.2	<i>Peak Output Power.....</i>	16
5.1.3	<i>20dB Bandwidth</i>	17
5.1.4	<i>Conducted spurious emissions and Frequency Band Edge measured in 100kHz Bandwidth.....</i>	22
5.1.5	<i>Spurious Emission</i>	31
5.1.6	<i>Frequency Separation.....</i>	32
5.1.7	<i>Number of hopping frequency.....</i>	34
5.1.8	<i>Time of Occupancy.....</i>	36
5.2	MAINS EMISSIONS.....	39
5.2.1	<i>Mains Conducted Emissions.....</i>	39
6.	SAFETY HUMAN EXPOSURE	40

6.1	RADIO FREQUENCY EXPOSURE COMPLIANCE	40
6.1.1	<i>Electromagnetic Fields.....</i>	<i>40</i>
7.	PHOTOGRAPHS OF THE TEST SET-UP.....	41
8.	LIST OF TABLES	45
9.	LIST OF PHOTOGRAPHS.....	45

1. General Remarks

1.1 Complementary Materials

The following attachments are integral parts of this test report:

Appendix P: Photo Documentation

(File Name: 50257350 001 Appendix P)

Appendix D: Test Result of Radiated Emissions

(File Name: 50257350 001 Appendix D)

Test Specifications

The following standards were applied

Table 1: Applied Standard and Test Levels

Radio
FCC CFR47 Part 15: Subpart C Section 15.247
FCC CFR47 Part 2: Subpart J Section 2.1091
ANSI C63.10: 2013
KDB Publication 447498 D01 General RF Exposure Guidance v06

2. Test Sites

2.1 Test Laboratory

TUV Rheinland Taiwan Ltd.

11F. No.758, Sec. 4, Bade Rd., Songshan Dist.
Taipei City 105
Taiwan (R.O.C.)

2.2 Test Facility

TUV Rheinland Taiwan Ltd.

11F. No.758, Sec. 4, Bade Rd., Songshan Dist.
Taipei City 105
Taiwan (R.O.C.)

FCC Registration No.: 180491
IC Canada Registration No.: 9465A
TAF Accredited NCC Test Lab. No.:3567
TAF ISO17025 Certification effective period: 6th-May-2019 to 05th-May-2022



Testing Laboratory
3567

2.3 List of Test and Measurement Instruments

Table 2: List of Test and Measurement Equipment

Equipment	Manufacturer	Model No.	Serial No.	Cal. Date	Cal. Due Date
EMI Test Receiver	Rohde & Schwarz	ESCI 7	100797	2019/01/16	2020/01/16
Spectrum Analyzer	Rohde & Schwarz	FSV-40	101112	2019/10/15	2020/10/15
Pre-Amplifier	Hewlett Packard	8447D	2944A09270	2019/09/18	2020/09/18
Pre-Amplifier	EM Electronics	EM01G18G	060649	2019/09/11	2020/09/11
Pre-Amplifier	EMC Instruments	EMC184045SE	980609(980408)	2019/06/14	2020/06/14
Bilog Antenna	TESEQ	CBL 6111D	40101	2019/10/23	2020/10/23
Horn Antenna	ETS-Lindgren	3117	00218931	2019/12/27	2020/12/27
Horn Antenna	Com-Power	AH-840	101029	2019/12/22	2020/12/22
Loop Antenna	Schwarzbeck	FMZB 1513	1513-076	2019/07/11	2020/07/11
Test Software	Audix	e3	Ver. 9	N/A	N/A
EMI Test Receiver	Rohde & Schwarz	ESCI 7	100797	2019/01/16	2020/01/16
Two-Line V- Network (for EUT)	Rohde & Schwarz	ENV216	101243	2019/06/23	2020/06/23
Two-Line V- Network	Rohde & Schwarz	ENV216	101262	2019/07/16	2020/07/16
Telecom ISN 4 Line	Fischer Custom Communications	FFCC-TLISN- T4-02-09	101168	2019/01/02	2020/01/02
Impedance Stabilization Network	TESEQ	ISN T800	51949	2019/02/20	2020/02/20
Pulse Limiter	Rohde & Schwarz	ESH3-Z2	0357.8810.54- 102102-HN	2019/07/25	2020/07/25

2.4 Traceability

All measurement equipment calibrations are traceable to NML(Taiwan)/NIST(USA) or where calibration is performed outside Taiwan, to equivalent nationally recognized standards organizations.

2.5 Calibration

requiring calibration is calibrated periodically in a suitably accredited Calibration Lab. Additionally all equipment is verified for proper performance on a regular basis using in house standards or comparisons.

2.6 Measurement Uncertainty

The estimated combined standard uncertainty for radiated emissions and conducted emissions measurements:

Table 3: Emission Measurement Uncertainty

Parameter	Uncertainty
Radio Frequency	± 0.1 ppm
RF power, conducted	± 1.5 dB
Adjacent channel power	± 3 dB
Radiated emission of transmitter, valid up to 26 GHz	± 6 dB
Radiated emission of receiver, valid up to 26 GHz	± 6 dB
Temperature	± 2 °C
Humidity	± 10 %

3. General Product Information

3.1 Product Function and Intended Use

The EUT is a Bluetooth Module. It contains a Bluetooth compatible module enabling the user to communicate data through a Wireless interface.
For details refer to the User Guide, Data Sheet and Circuit Diagram.

3.2 System Details and Ratings

Table 4: Basic Information of EUT

Item	EUT information
Kind of Equipment/Test Item	BT RF Module
Type Identification	AK-888
FCC ID	2AOG5-888

Table 5: Technical Specification of EUT

Technical Specification	Value
Operating Frequency	2402 MHz ~ 2480 MHz
Channel Spacing	1 MHz
Channel number	79
Operation Voltage	3.3Vdc
Modulation	GFSK, $\pi/4$ DQPSK, 8 DPSK
Antenna gain	2dBi

Table 6: Frequency hopping information

Technical Specification	Description
Hopping Range	<p>Hereby we declare that the maximum frequency of this device is: 2402-2480MHz. This is according the Bluetooth Core Specification V2.1+EDR for devices which will be operated in the USA. This was checked during the Bluetooth Qualification tests (Test Case: TRM/CA/04).</p>
Hopping Sequence	<p>Example of a 79 hopping sequence in data mode:</p> <p>33,04,21,44,23,42,53,46,55,48,40,59,72,29,76,31,08,73,07,75,09,45,60,39,58,13,47,11,77,52,35,50,65,54,67,56,69,62,71,64, 7,25,27,66,57,70,74,61,78,63,10,41,05,43,15,44,64,68,02,70,06,01,51,03,55,05,03,66,53,49,36,47,</p>
Receiver input bandwidth	<p>The input bandwidth of the receiver is 1MHz. In every connection one Bluetooth device is the master and the other one is the slave. The master determines the hopping sequence. The slave follows this sequence. Both devices shift between RX and TX time slot according to the clock of the master.</p> <p>Additionally the type of connection is set up at the beginning of the connection. The master adapts its hopping frequency and its TX/RX timing according to the packet type of the connection. Also the slave of the connection will use these settings.</p> <p>Repeating of a packer has no influence on the hopping sequence. The hopping sequence generated by the master of the connection will be followed in any case.</p> <p>That means a repeated packet will not be send on the same frequency, it is send on the next frequency of the hopping sequence.</p>

3.3 Independent Operation Modes

The basic operation modes are:

- A. Transmitting
 - 1. Low channel
 - 2. Middle channel
 - 3. High channel

- B. Receiving
 - 1. Low channel
 - 2. Middle channel
 - 3. High channel

- C. Hopping

3.4 Noise Generating and Noise Suppressing Parts

Refer to the Circuit Diagram.

3.5 Submitted Documents

- Circuit Diagram
- Instruction Manual
- Rating Label
- Technical Description

4. Test Set-up and Operation Modes

4.1 Principle of Configuration Selection

The test modes were adapted accordingly in reference to the instructions for use.

During testing, Channel and Power Controlling Software provided by the customer was used to control the operating channel as well as the output power level. The RF output power selection is for the setting of RF output power expected by the customer and is going to be fixed on the firmware of the final end product.

Table 7: Table for Parameters of Test Software Setting

Mode	Operation Frequency		
	2402 MHz	2441 MHz	2480 MHz
1DH5	11	8	11
3DH5	12	12	13

4.2 Test Operation and Test Software

Setup for testing: Test samples are provided with a USB interface which makes it possible to control them through a test software installed on a notebook computer.

This software HCI_Data_Test.exe was running on the laptop computer connected to the EUT. It was used to enable the operation modes listed in section 3.3 as appropriate.

The samples were used as follows:
A000968792-001

Full test was applied on all test modes, but only worst case was shown.

4.3 Special Accessories and Auxiliary Equipment

The product has been tested together with the following additional accessories:

Description	Manufacturer	Model No.	Serial No.
Notebook(EMC-06)	Lenovo	TP00048A	PB-0F8B2

4.4 Countermeasures to achieve EMC Compliance

The test sample which has been tested containing the noise suppression parts as in the Photo Appendix and the Test Setup Photos. No additional measures were employed to achieve compliance.

4.5 Test Setup Diagram

Diagram of Measurement Configuration for Radiation Test

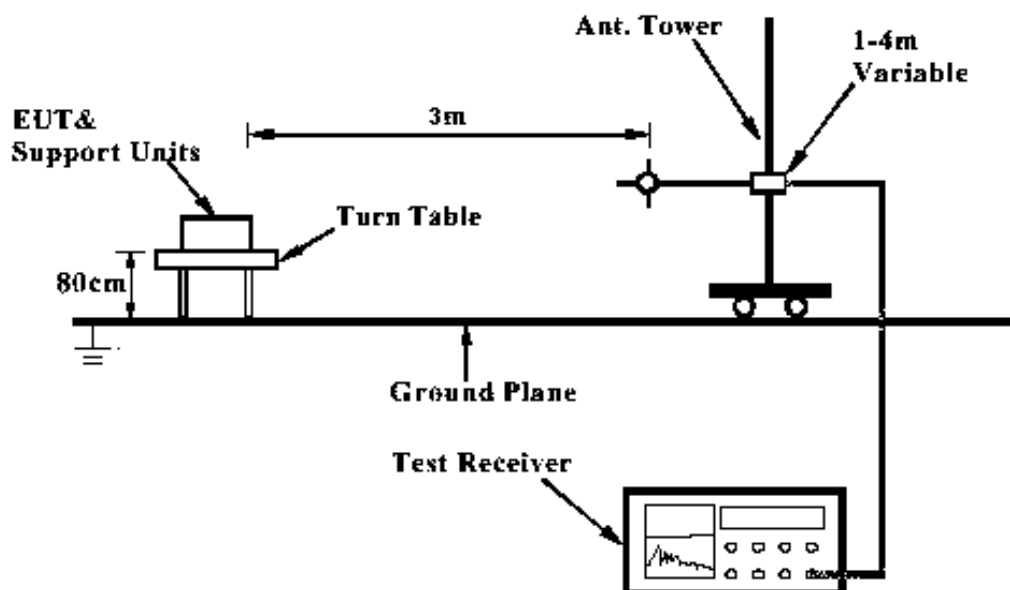

Note: Measurements above 1 GHz are done with a table height of 1.5m

Diagram of Measurement Equipment Configuration for Mains Conduction Measurement

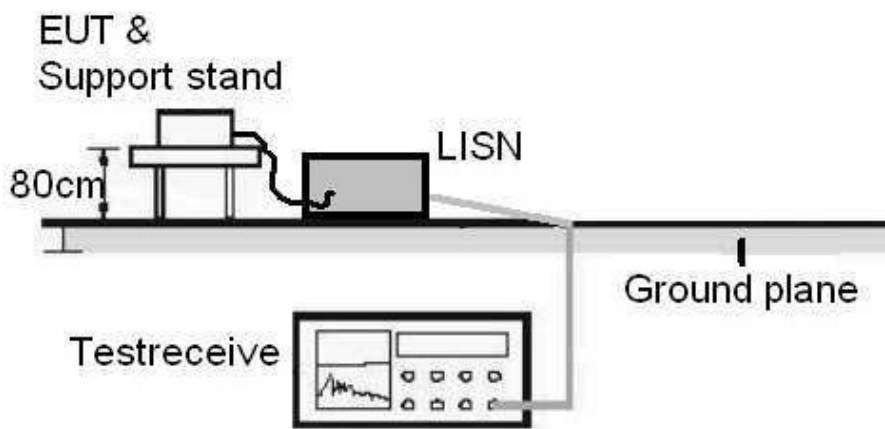
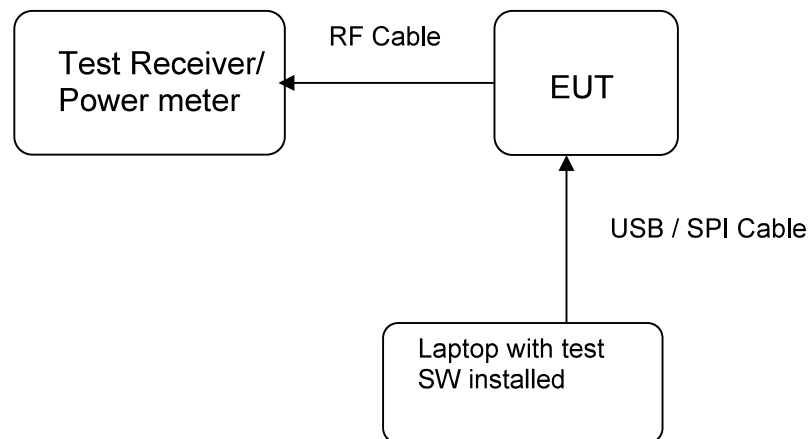

Diagram of Measurement Equipment Configuration for Conducted Transmitter Measurement



5. Test Results

5.1 Transmitter Requirement & Test Suites

5.1.1 Antenna Requirement

RESULT: **Passed**

Test standard : FCC Part 15.247(b)(4), Part 15.203

Requirement : use of approved antennas only with directional gains that do not exceed 6 dBi

According to the manufacturer declaration, the EUT has an antenna with a directional gain of 2dBi. The antenna is a Dipole antenna with no possibility of replacement with a non-approved antenna by the end-user. Therefore, the EUT is considered to comply with this provision.

Refer to EUT photo for details.

5.1.2 Peak Output Power

RESULT:
Passed

Test standard : FCC Part 15.247(b)(1)
 Basic standard : ANSI C63.10:2013
 Kind of test site : Shielded room

Test setup

Test Channel : Low/ Middle/ High
 Operation Mode : A
 Ambient temperature : 22-26 °C
 Relative humidity : 50-65 %
 Atmospheric pressure : 100-103 kPa

Table 8: Test result of Peak Output Power, 1DH5

Channel	Channel Frequency	Peak Output Power		Limit
	(MHz)	(dBm)	(W)	(W)
Low Channel	2402	-10.18	0.0001	0.125
Middle Channel	2441	-17.33	0.00002	0.125
High Channel	2480	-8.81	0.00013	0.125

Table 9: Test result of Peak Output Power, 3DH5

Channel	Channel Frequency	Peak Output Power		Limit
	(MHz)	(dBm)	(W)	(W)
Low Channel	2402	-4.91	0.00032	0.125
Middle Channel	2441	-3.53	0.00044	0.125
High Channel	2480	0.61	0.00115	0.125

5.1.3 20dB Bandwidth

RESULT:
Passed

Test standard : FCC Part 15.247(a)(1),
 Basic standard : ANSI C63.10:2013
 Kind of test site : Shielded room

Test setup

Test Channel : Low/ Middle/ High
 Operation Mode : A
 Ambient temperature : 22-26°C
 Relative humidity : 50-65%
 Atmospheric pressure : 100-103kPa

Table 10: Test result of 20dB Bandwidth, 1DH5

Channel	Channel Frequency (MHz)	20dB Bandwidth (MHz)	Limit (MHz)	Result
Low Channel	2402	1.028	1.5	Pass
Mid Channel	2441	1.027	1.5	Pass
High Channel	2480	1.029	1.5	Pass

Note: Limit is for Channel Separation of 1 MHz and a power limit of 125 mW.

Table 11: Test result of 20dB Bandwidth, 3DH5

Channel	Channel Frequency (MHz)	20dB Bandwidth (MHz)	Limit (MHz)	Result
Low Channel	2402	1.351	1.5	Pass
Mid Channel	2441	1.347	1.5	Pass
High Channel	2480	1.345	1.5	Pass

Note: Limit is for Channel Separation of 1 MHz and a power limit of 125 mW.

If the carrier separation frequency of a Bluetooth Device is set at 1 MHz due to the firmware setting and the Bluetooth Standard, then for power <125 mW the limit for the 20 dB Bandwidth, becomes $1 \text{ MHz} / 0.66666 = 1.5 \text{ MHz}$.

Test Plot of 20dB Bandwidth, 1DH5

Low Channel



Middle Channel



High Channel

Test Plot of 20dB Bandwidth, 3DH5

Low Channel



Middle Channel



High Channel

5.1.4 Conducted spurious emissions and Frequency Band Edge measured in 100kHz Bandwidth

RESULT:**Passed**

Test standard	:	FCC part 15.247(d)
Basic standard	:	ANSI C63.10:2013
Limit	:	20dB (below that in the 100kHz bandwidth within the band that contains the highest level of the desired power)
Kind of test site	:	Shielded room

Test setup

Test Channel	:	Low/ Middle/ High for Conducted Spurious Emissions Low/ High/ Hopping on for Frequency Band Edge
Operation Mode	:	A
Ambient temperature	:	22-26°C
Relative humidity	:	50-65%
Atmospheric pressure	:	100-103 kPa

All emissions are more than 20dB below fundamental, details refer to following test plot, and compliance is achieved as well.

Due to the small size of the RF circuit and that there are no inductive components of significant size connected to the antenna port, 9kHz to 30MHz frequency range is not tested based on technical judgment.

Test Plot of 100kHz Bandwidth of Frequency Band Edge, 1DH5

Low Channel

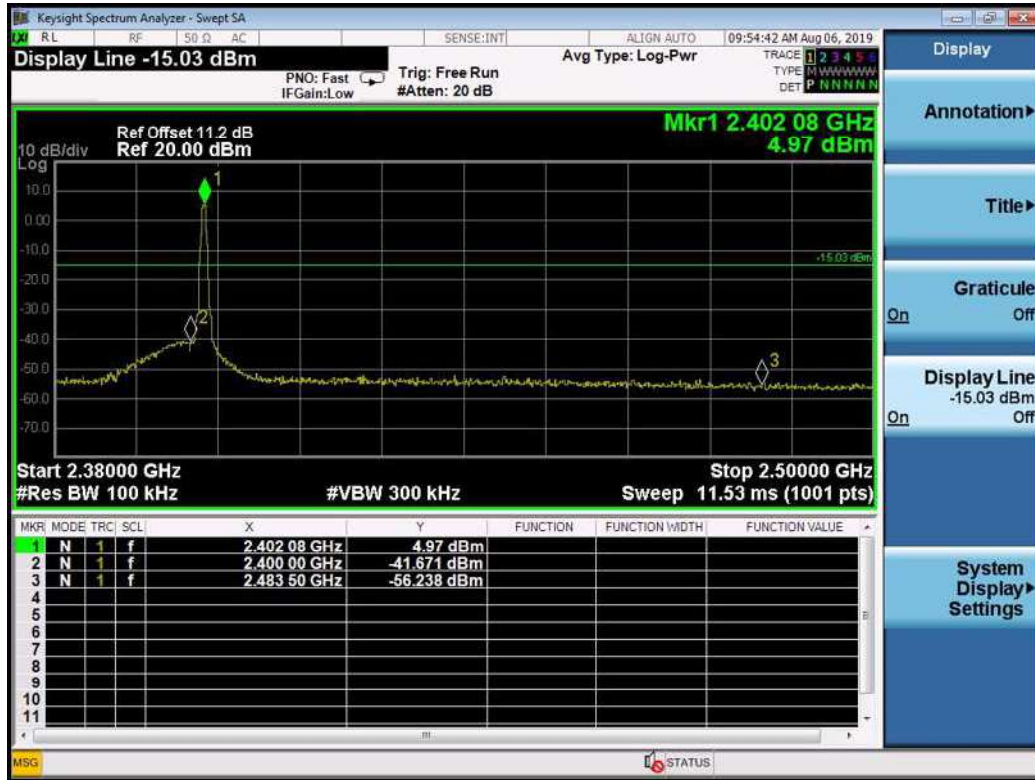

High Channel

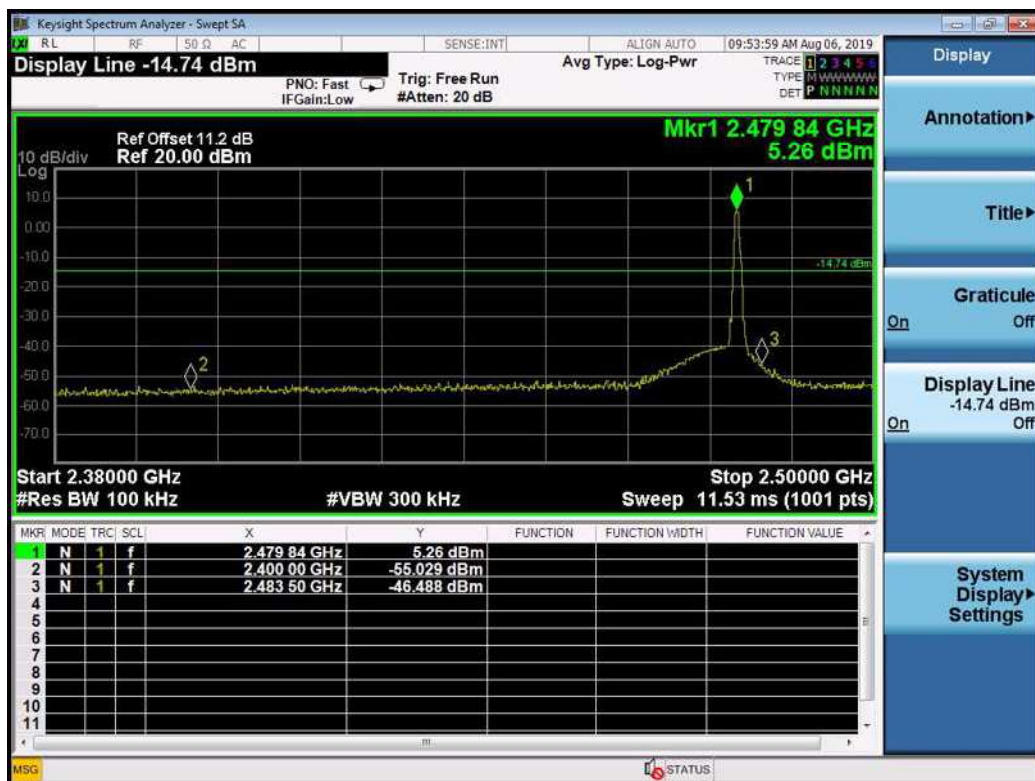

Test Plot of 100kHz Bandwidth of Frequency Band Edge, 3DH5

Low Channel

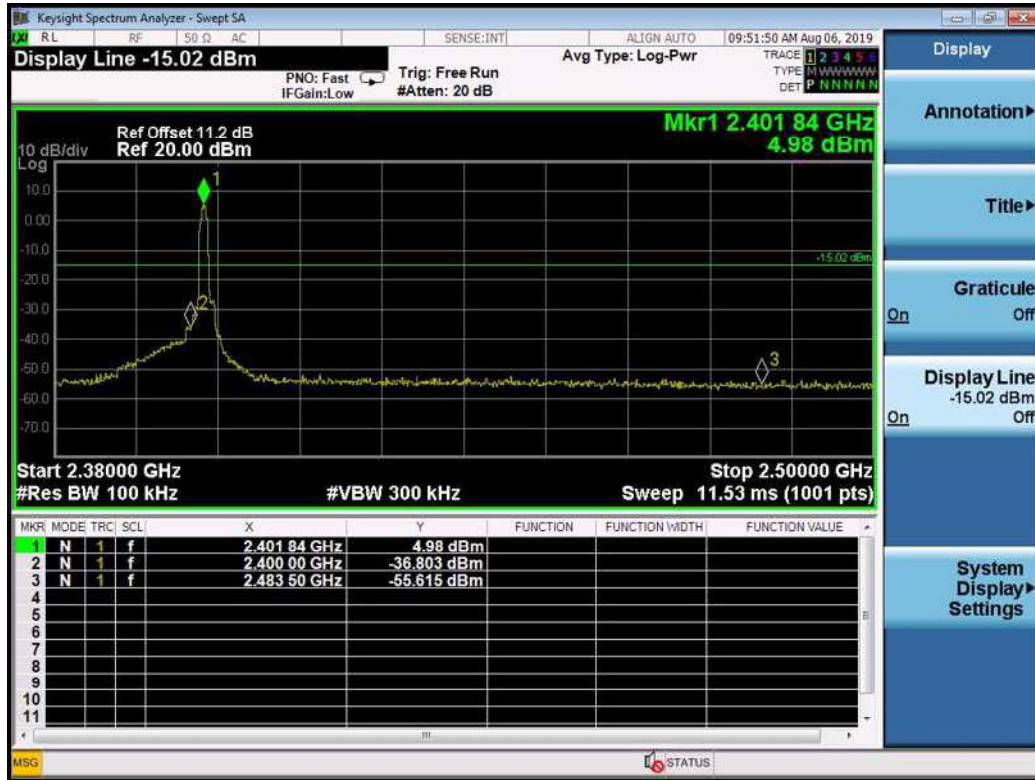

High Channel

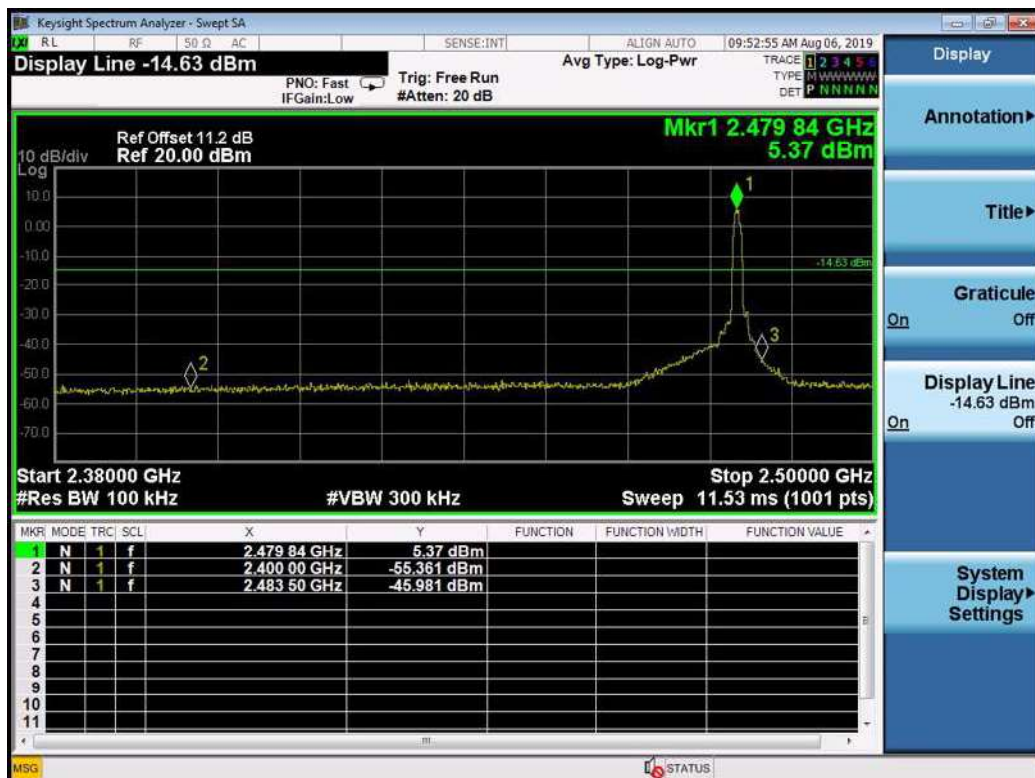

5.1.5 Spurious Emission

RESULT:**Passed**

Test standard	:	FCC part 15.247(d), FCC 15.205, FCC 15.209
Basic standard	:	ANSI C63.10: 2013
Limits	:	Radiated emissions which fall in the restricted bands, as defined in FCC 15.205(a) and RSS-Gen i5, 8.10 (Table 7), must comply with the radiated emission limits specified in FCC 15.209(a) and RSS-Gen 5, 8.9 (Table 5 and 6). Emission radiated outside the restricted and authorized frequency bands must either comply with the radiated emission limits specified for the restricted bands or in FCC15.247(d) and RSS-247 i2, 5.5
Kind of test site	:	3m Semi-Anechoic Chamber

Test setup

Test Channel	:	Low/ Middle/ High
Operation Mode	:	A
Ambient temperature	:	22-26°C
Relative humidity	:	50-65%
Atmospheric pressure	:	100-103 kPa

Remark: Testing was carried out within frequency range 9kHz to the tenth harmonic. For details refer to Appendix D. The Radiated Emissions testing was performed in the X, Y and Z axis orientation. The worst-case Axis orientation is recorded in this test report.

5.1.6 Frequency Separation

RESULT:
Passed

Test standard : FCC part 15.247(a)(1)
 Basic standard : ANSI C63.10:2013
 Limit : $\geq 25\text{kHz}$ or $2/3$ of 20dB bandwidth, whichever is greater
 Kind of test site : Shielded room

Test setup

Test Channel : Hopping On
 Operation Mode : C
 Ambient temperature : 22-26°C
 Relative humidity : 50-65%
 Atmospheric pressure : 100-103 kPa

Table 12: Test result of Frequency Separation

Channel	Channel Frequency (MHz)	Measured Channel Separation (MHz)	Limit (kHz)	Result
Record Channel	2441	1	$\geq 25\text{kHz}$ or $2/3$ of 20dB bandwidth	Pass
Record Channel adj 1	2440			
Record Channel adj 2	2442			

5.1.7 Number of hopping frequency

RESULT:
Passed

Test standard : FCC part 15.247(a)(1)(iii)
 LP0002(2018): 3.10.1, (6.1.2)
 Basic standard : ANSI C63.10:2013
 LP0002(2018) Appendix II
 Kind of test site : Shielded room

Test setup

Test Channel : Hopping On
 Operation Mode : C
 Ambient temperature : 22-26°C
 Relative humidity : 50-65%
 Atmospheric pressure : 100-103 kPa

Table 13: Test result of Number of hopping frequency

Frequency Range	Measured Quantity of Hopping Channel	Limit	Result
2400 to 2483.5 MHz	79	≥15	Pass

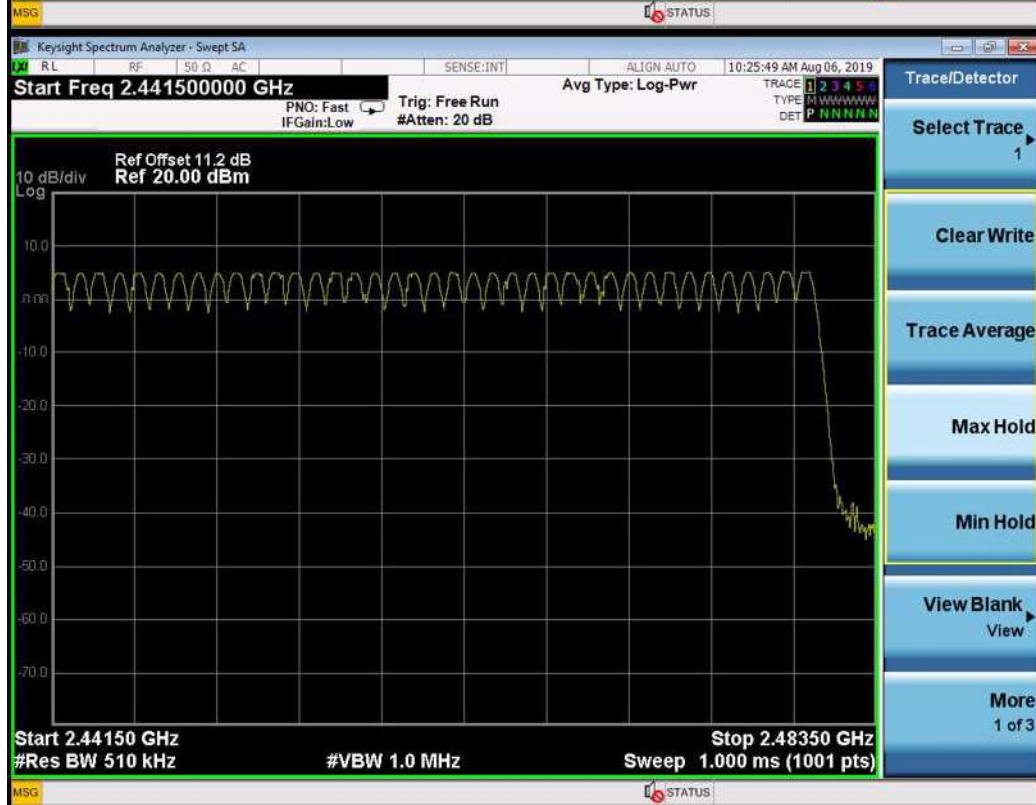
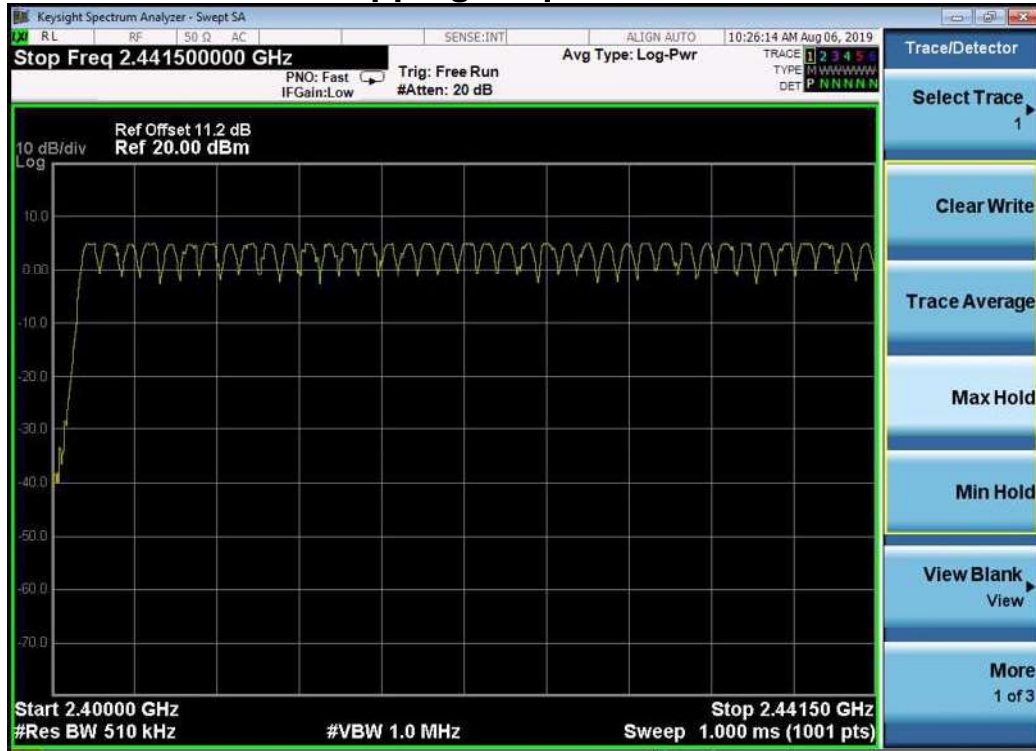
Test Plot of Number of hopping frequencies

5.1.8 Time of Occupancy

RESULT:
Passed

Test standard : FCC part 15.247(a)(1)(iii)
 RSS-247 5.1(5)
 LP0002(2018): 3.10.1, (6.1.2)
 Basic standard : ANSI C63.10:2013
 LP0002(2018) Appendix II
 Limits : 0.4s
 Kind of test site : Shield room

Test setup

Test Channel : Low
 Operation Mode : A
 Ambient temperature : 22-26°C
 Relative humidity : 50-65%
 Atmospheric pressure : 100-103 kPa

Table 14: Test result of Time of Occupancy

Data Mode	Captured Burst (s)	Dwell time (s)	On+Off time (s)	Limit (s)	Result
1DH5	0.00294	0.3128	0.00376	0.4	Pass
3DH5	0.00289	0.3074	0.00376	0.4	Pass

Note:

Dwell time = Pulse width x (Hopping rate / Number of channels) x Period

Period = 0.4 (seconds/ channel) x 79 (channel) = 31.6 seconds.

Hopping rate = 1 / (On+Off time) = 266 Hz

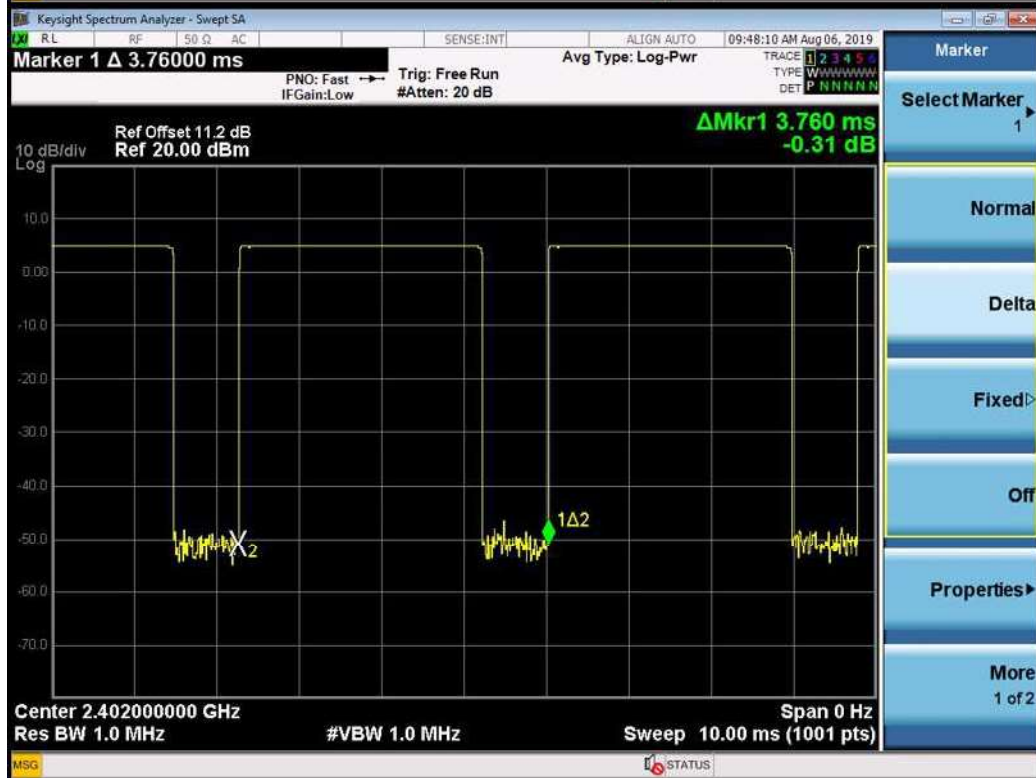
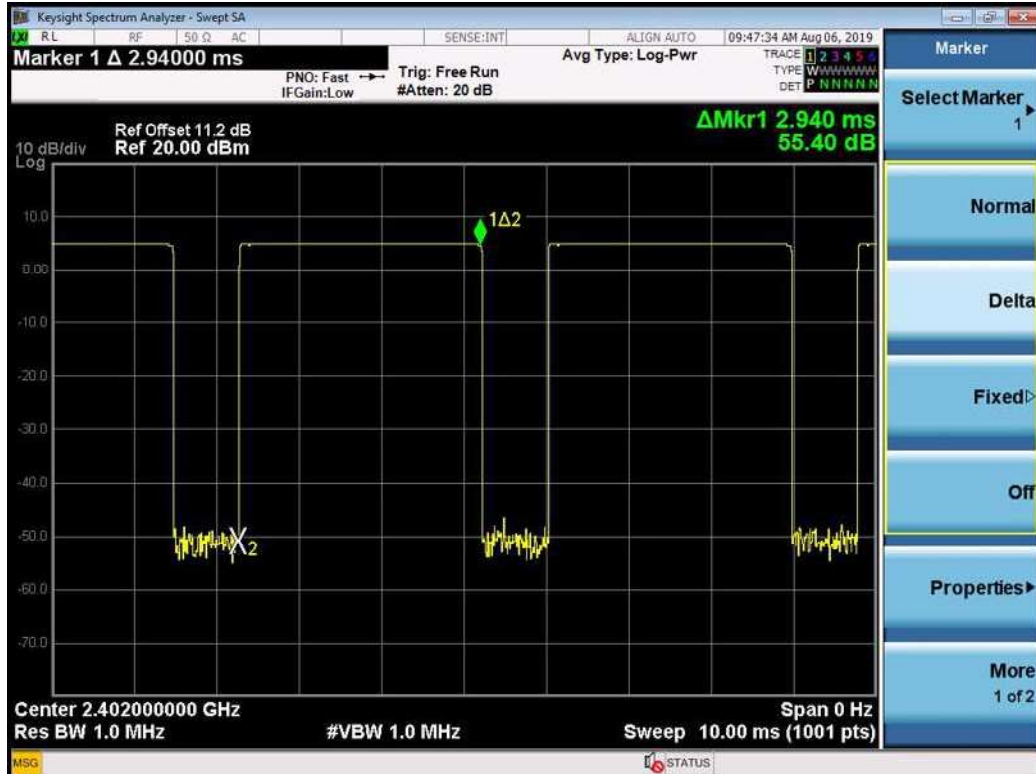
Test Plot of Time of Occupancy, 1DH5

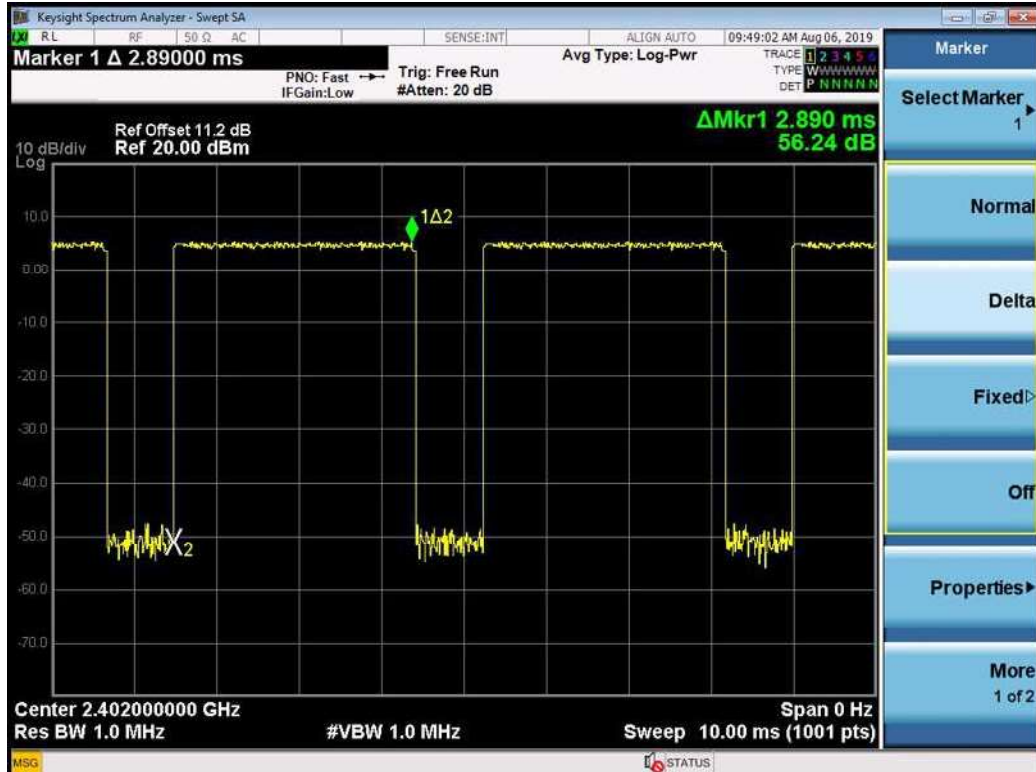
Test Plot of Time of Occupancy, 3DH5

5.2 Mains Emissions

5.2.1 Mains Conducted Emissions

RESULT:**Passed**

Test standard	:	FCC Part 15.207 FCC Part 15.107
Limits	:	Mains Conducted emissions as defined in above test standards must comply with the mains conducted emission limits specified
Kind of test site	:	Shielded Room
Test setup		
Test Channel	:	Low
Operation mode	:	A
Ambient temperature	:	22-26°C
Relative humidity	:	50-65%
Atmospheric pressure	:	100-103 kPa

Remark: For details refer to Appendix D.

6. Safety Human exposure

6.1 Radio Frequency Exposure Compliance

6.1.1 Electromagnetic Fields

RESULT:
Passed

Test standard : FCC KDB Publication 447498 D01

FCC:

Separation distance is more than 20 cm, thus mobile device exposure limits can be applied.

Maximum Exposure:

Power to Antenna (mW)	1.15 mW
Power to Antenna (dBm)	0.6 dBm
Antenna Gain	2 dBi
Power+Ant Gain	1.8 mW
Distance	20 cm
S=	0.00036 mW/cm ²

Limit FCC:

1500-100,000 MHz 1.0 mW/cm²

7. Photographs of the Test Set-Up

Photograph 1: Set-up for Spurious Emissions (Front View)



Photograph 2: Set-up for Spurious Emissions (Back View 1)

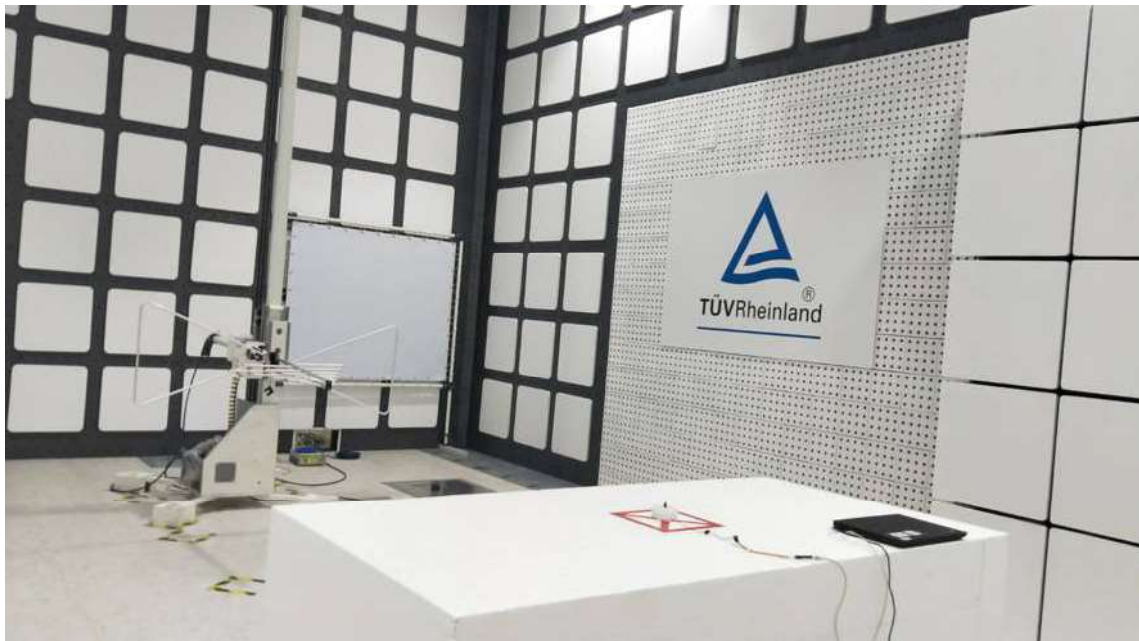

Photograph 3: Set-up for Spurious Emissions (Back View 2)

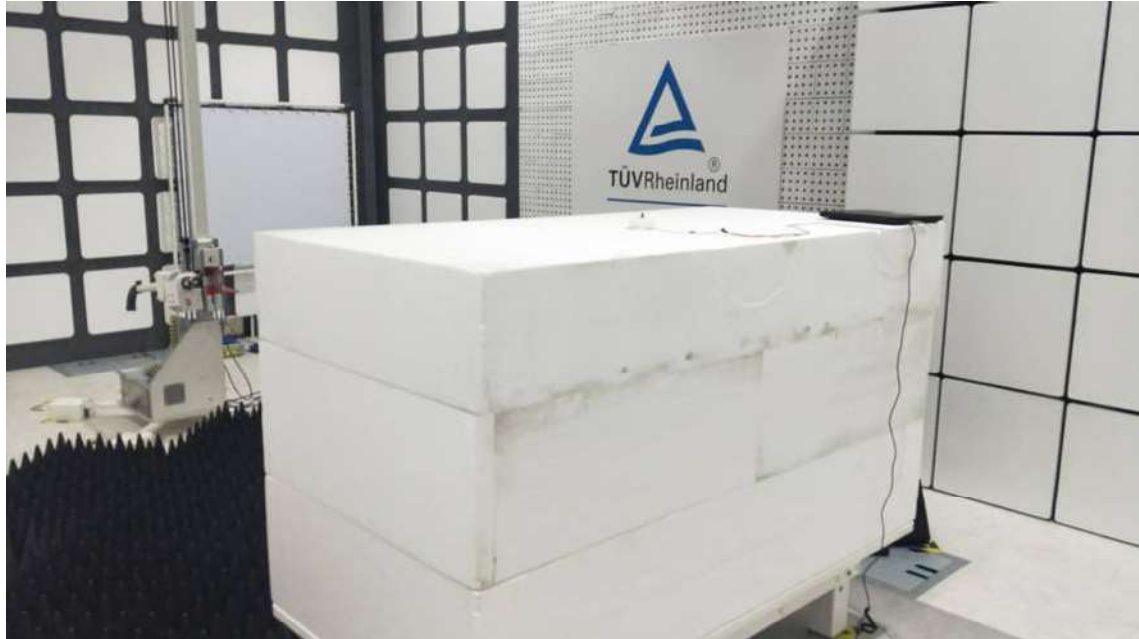

Photograph 4: Set-up for Spurious Emissions (Back View 3)

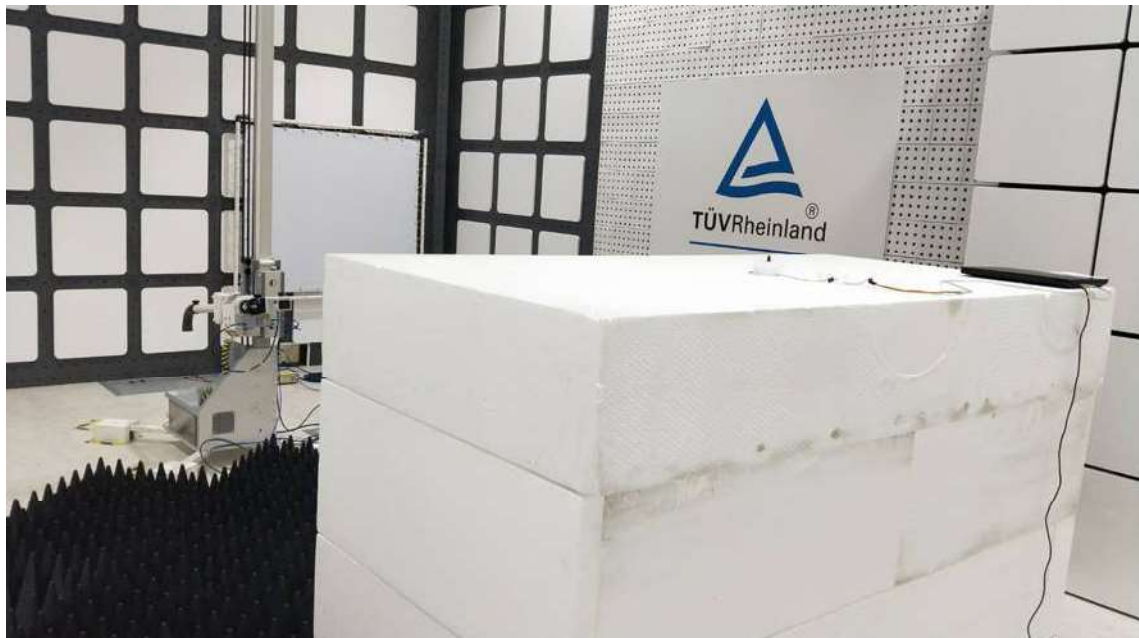

Photograph 5: Set-up for Conducted testing (View 1)



Photograph 6: Set-up for Conducted testing (View 2)

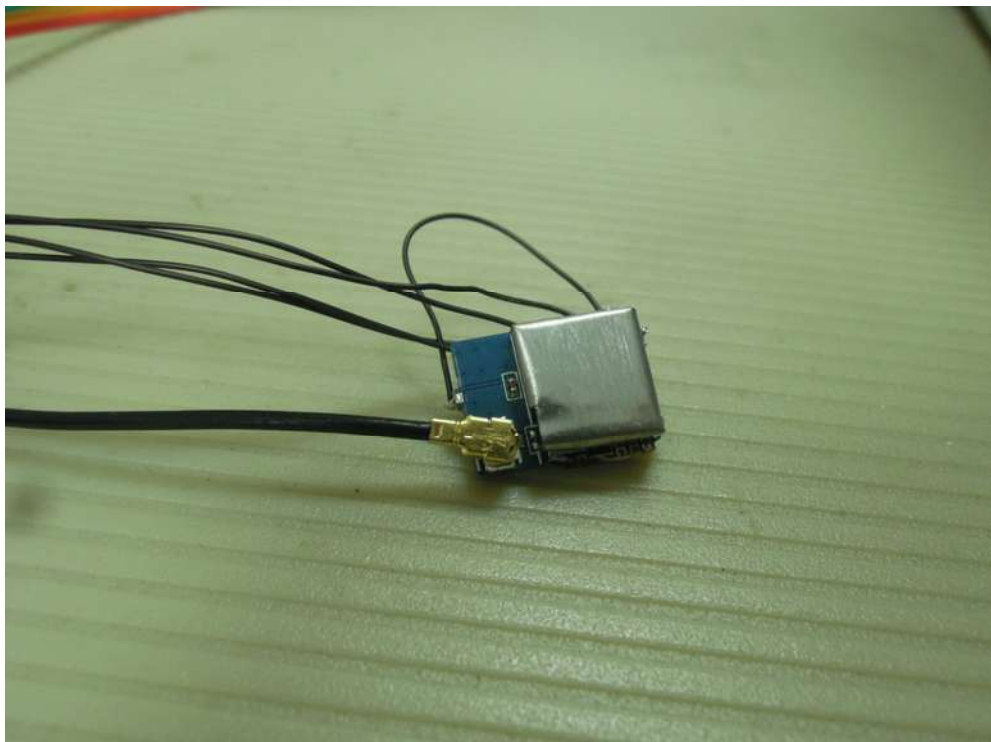

Photograph 7: Set-up for for Mains Conducted testing Back



Photograph 8: Set-up for for Mains Conducted testing Front



8. List of Tables

Table 1: Applied Standard and Test Levels	5
Table 2: List of Test and Measurement Equipment	7
Table 3: Emission Measurement Uncertainty.....	8
Table 4: Basic Information of EUT	9
Table 5: Technical Specification of EUT	9
Table 6: Frequency hopping information.....	10
Table 7: Table for Parameters of Test Software Setting	12
Table 8: Test result of Peak Output Power, 1DH5	16
Table 9: Test result of Peak Output Power, 3DH5	16
Table 10: Test result of 20dB Bandwidth, 1DH5	17
Table 11: Test result of 20dB Bandwidth, 3DH5	17
Table 12: Test result of Frequency Separation	32
Table 13: Test result of Number of hopping frequency	34
Table 14: Test result of Time of Occupancy.....	36

9. List of Photographs

Photograph 1: Set-up for Spurious Emissions (Front View).....	41
Photograph 2: Set-up for Spurious Emissions (Back View 1).....	41
Photograph 3: Set-up for Spurious Emissions (Back View 2).....	42
Photograph 4: Set-up for Spurious Emissions (Back View 3).....	42
Photograph 5: Set-up for Conducted testing (View 1).....	43
Photograph 6: Set-up for Conducted testing (View 2).....	43
Photograph 7: Set-up for for Mains Conducted testing Back.....	44
Photograph 8: Set-up for for Mains Conducted testing Front.....	44