

Zhejiang Lierda Internet of Things Technology Co.,Ltd.

LSD1RF-ST433M00

User manual

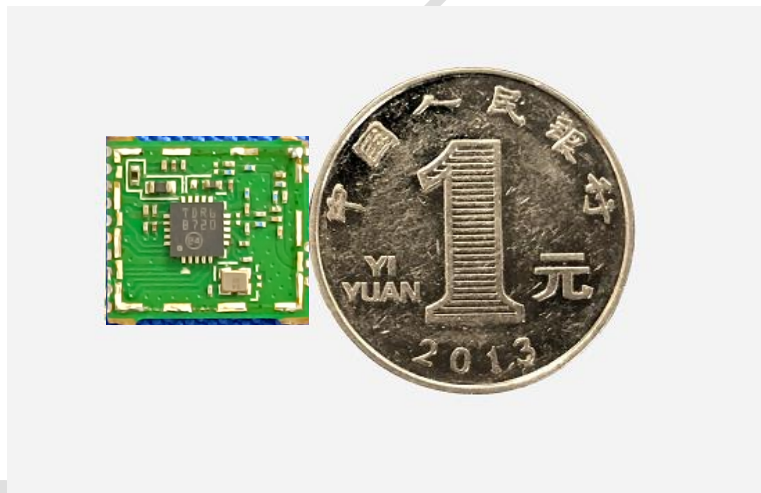

Product Name: 433M Wireless Communication Module

Product Model: LSD1RF-ST433M00

Document Version: V0.2

Document Modification Record

Product Name	433M Wireless Communication Module	Product Model		LSD1RF-ST433M00	
Prepared by:	Qiu Mangang	Prepared on		Sep. 27, 2018	
S/N	Revision Log	Modified by	Reviewed by	Document Version	Modification Date
1	Initial Version	Qiu Mangang		V0.1	Sep. 27, 2018
2	Updated Version	Chen Guo'an		V0.2	Aug. 8, 2019

DRAFT

Contents

Chapter I: Functional Features	4
Chapter II: Specification Parameters	5
Chapter III: Hardware Layout and Interface Description	6
3.1 Overall Dimension Diagram	6
3.2 Interface Description	7
Chapter IV: Module Application	8
4.1 Typical Application Circuit	8
4.2 Module Usage Interface	9
4.3 Precautions for Use	10
Chapter V: Reflow Soldering Operation Instruction	12
Notes to Users	13

Chapter I: Functional Features

LSD1RF-ST433M00 Wireless Module, a RF module designed based on RF integrated chip SPIRIT1, is a high-performance IoT wireless transceiver, which can be widely used in the field of short-range IoT wireless communication for various occasions. It has the characteristics of small size, low power consumption, long transmission distance and strong anti-interference ability, etc. Customers can have diverse antenna solutions available in accordance with the actual application, mainly for the secondary development of customers.

The excellent characteristics of RF performance and low power consumption meet customers' various needs, and the complete integrated RF solution shortens the development cycle for counterparts, so they can devote more time to the development of terminal applications.

Module features

- **Support FSK, 2-FSK, OOK, ASK**
- **SPI communication interface, which can be directly connected to copious microcontrollers, is very convenient for software programming.**
- **Can set a variety of programmed communication data 1--500kbps**
- **Matching Hardware CRC,AES-128**

Application Field

- ✓ **Wireless meter reading system, especially suitable for water meters, gas meters, heat meters, electricity meters and other wireless meters reading occasions;**
- ✓ **Wireless sensor network system;**
- ✓ **Smart homes, smart buildings;**
- ✓ **Industrial remote sensing, telemetry communications;**
- ✓ **Wireless home security, monitoring cloud platform, machine room power supply, wireless remote control alarm system for wind turbine equipment;**
- ✓ **Active RFID tag identification;**
- ✓ **POS system, wireless intelligent terminals such as PDA, medical instrument;**
- ✓ **Electronic bus stop board, intelligent traffic dispatching system;**

Chapter II: Specification Parameters

Table 1 Module Parameters

Main parameters		Performance			Remarks
		Minimum value	Typical value	Maximum value	
Working voltage		1.9V	3.3V	3.6V	
Operating temperature		-40°C	25°C	85°C	
Crystal frequency		-	24M	-	Please pay attention to modification when configuring the program
Working frequency band		-	433M	-	
Power consumption	Transmit (mA)		55	60	@3.3V 16dBm CW 433M
	Transmit (mA)		29	32	@3.3V 11dBm CW 433M
	Receive (mA)		9	10	@3.3V 433M
	Sleep (uA)		0.6	1	@Standby
Initial frequency deviation (k)		-5	0	+5	
Emission power (dBm)		-	16	-	-30dBm - 16dBm programmable. This default configuration is BOOST mode
Receiving sensitivity (dBm)		-	-101	-99	@38.4K 0.1% BER 2-FSK 433M
Communication Rate	FSK(Kbps)	1	-	500	
	OOK(Kbps)	1	-	250	
Interface type		Stamp hole 1.27mm pitch			
Modulation mode		FSK, GFSK, OOK, ASK			
Communication distance		550m			@38.4K 17dbm 2-FSK 433M Affected by antenna and environmental factors, the actual test shall prevail
Antenna type		Antenna external connection			
Communication protocol		SPI			Support maximum communication rate 10M
Overall dimension (mm)		13 *15.0			Organization: mm PCB Dimension
Shielding case		None			

Chapter III: Hardware Layout and Interface Description

3.1 Overall Dimension Diagram

LSD1RF-ST433M00 The overall dimension of module is shown in Figure 1

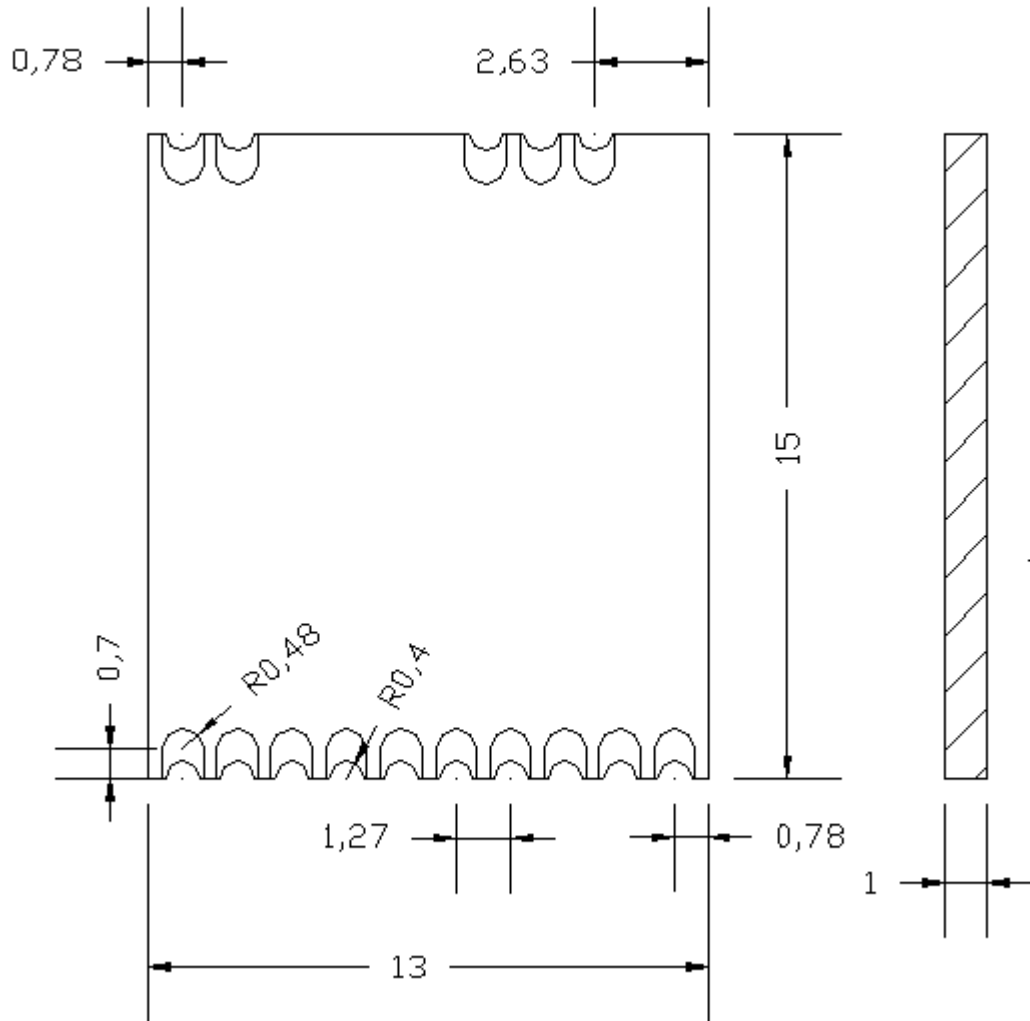

Unit: mm

Figure 1 Module Dimension Diagram

3.2 Interface Description

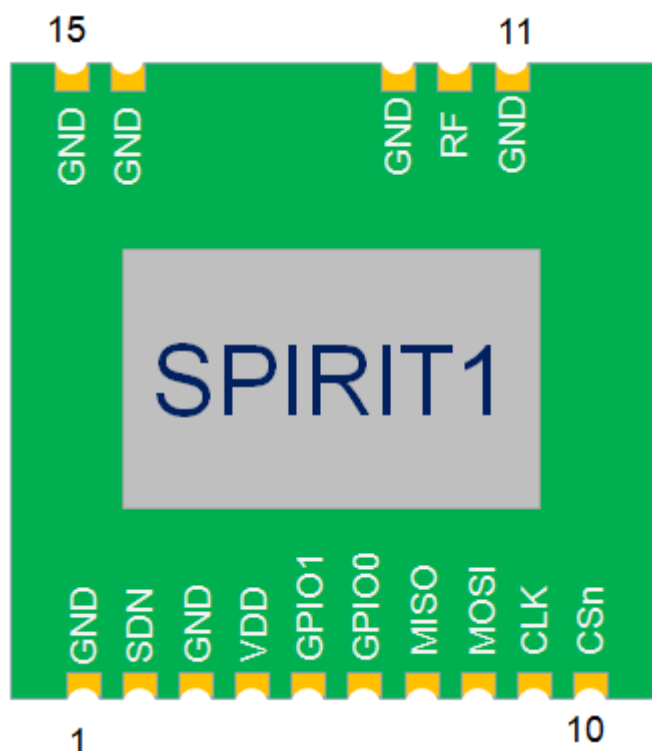

Figure 2 Module Pin Definition

Table 2 Module Pin Description

S/N	Interface name	Function	S/N	Interface name	Function
1	GND	Ground (must be grounded)	9	CLK	SPI clock
2	SDN	SRAM reading enable signal (Low level active)	10	CSn	SPI chip selection signal
3	GND	Ground (must be grounded)	11	GND	Ground (must be grounded)
4	VDD	Power supply	12	RF	Wireless signal input and output terminal
5	GPIO1	Interrupt signal (optional)	13	GND	Ground (must be grounded)
6	GPIO0	Interrupt signal (optional)	14	GND	Ground (must be grounded)
7	MISO	SPI slave machine data output	15	GND	Ground (must be grounded)
8	MOSI	SPI slave machine data input			

Notes: [For more information about the module pin, please refer to the SPIRIT1 data manual](#)

Chapter IV: Module Application

4.1 Typical Application Circuit

The configuration of the minimum system of the module is as follows, power and ground must be connected stably. The module supports four-wire SPI interface (CSn, SCLK, SDO, SDI), which needs to be connected to the MCU for control. SDn is the module that can make the pin low effective to use the ordinary IO port for control, GPIO0 - GPIO1 for two interrupt pins can choose to be connected according to the need.

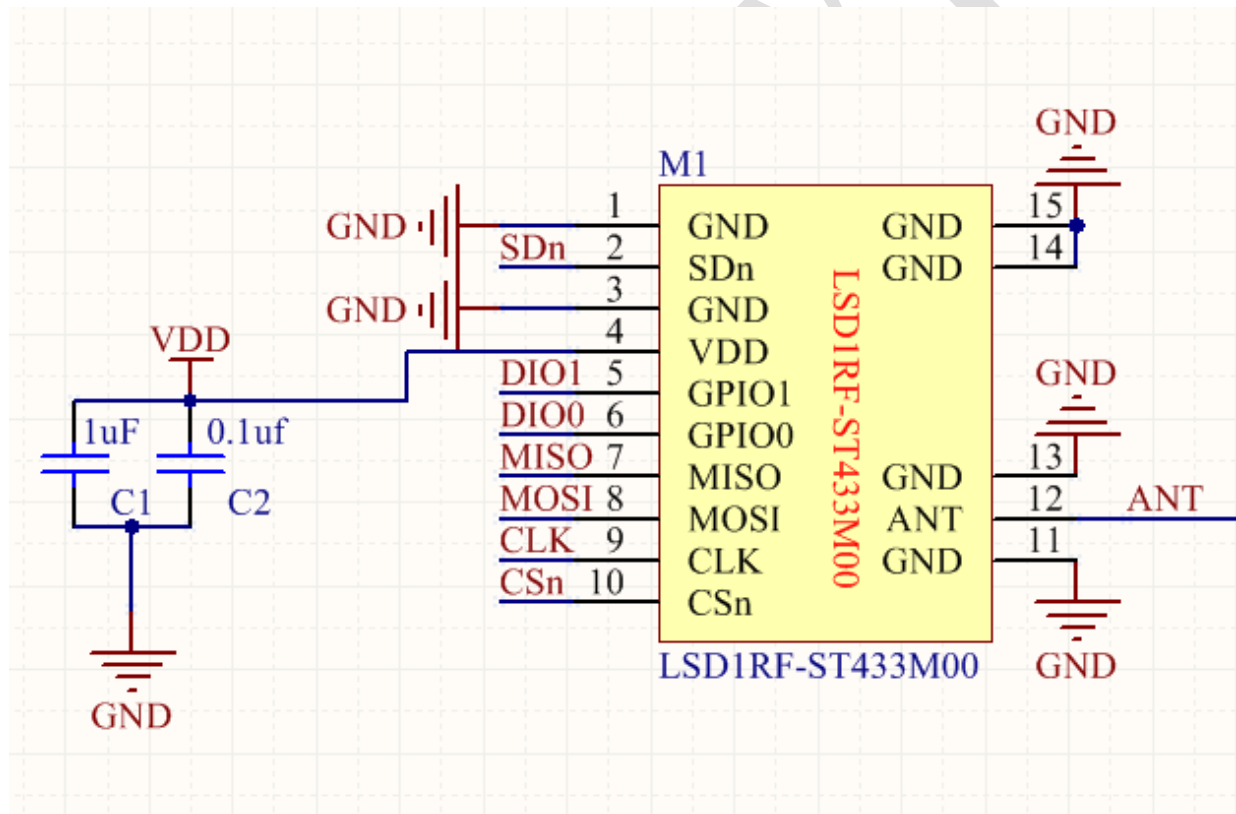

Figure 3 Module Power Supply Interface

The module antenna is external, the antenna interface is recommended to add the following matching circuit choose 0402 package.

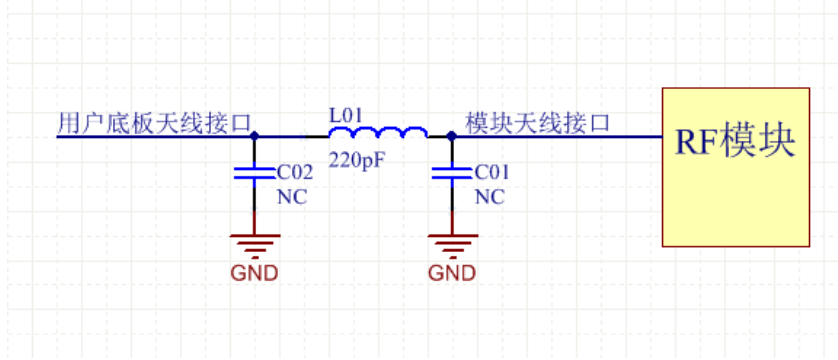

Figure 4 Module Antenna Interface Recommended Circuit

4.2 Module Usage Interface

Insert the module into the user's board, use the microcontroller and the module for SPI communication, and operate its control register and transceiver cache, which can complete the wireless data transceiver function. Among them, the sequence of module register read and write operations is shown in the figure. For detailed operations, please refer to the latest SPIRIT1 data manual

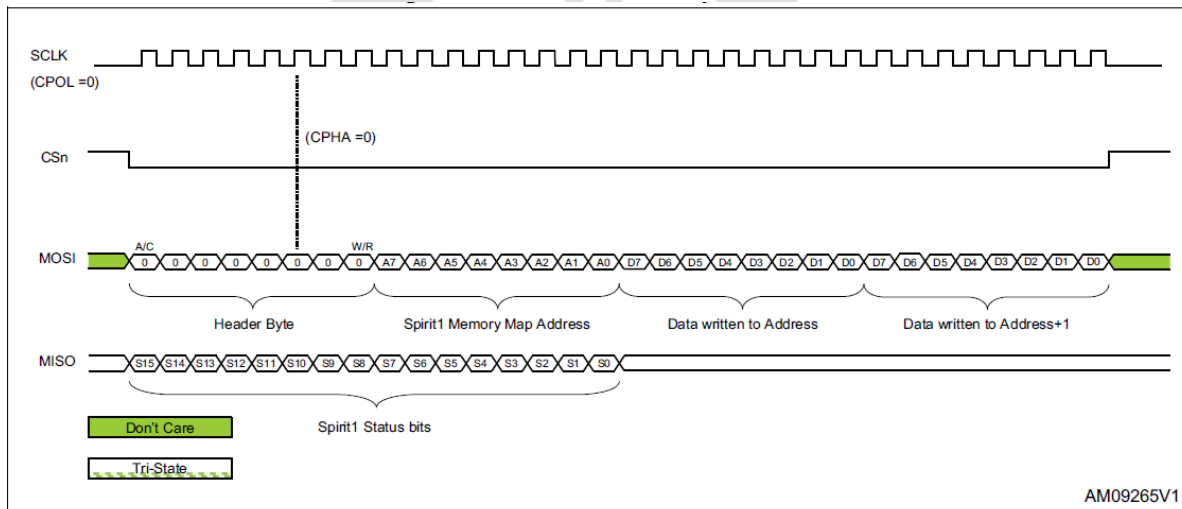

Figure 5 Module SPI Write Timing

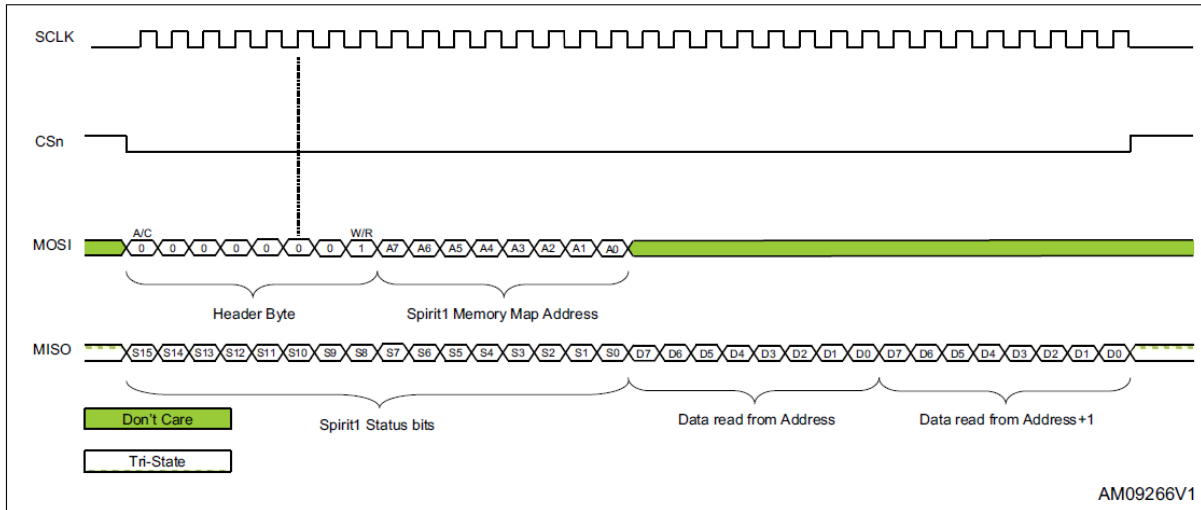

Figure 6 Module SPI Read Timing

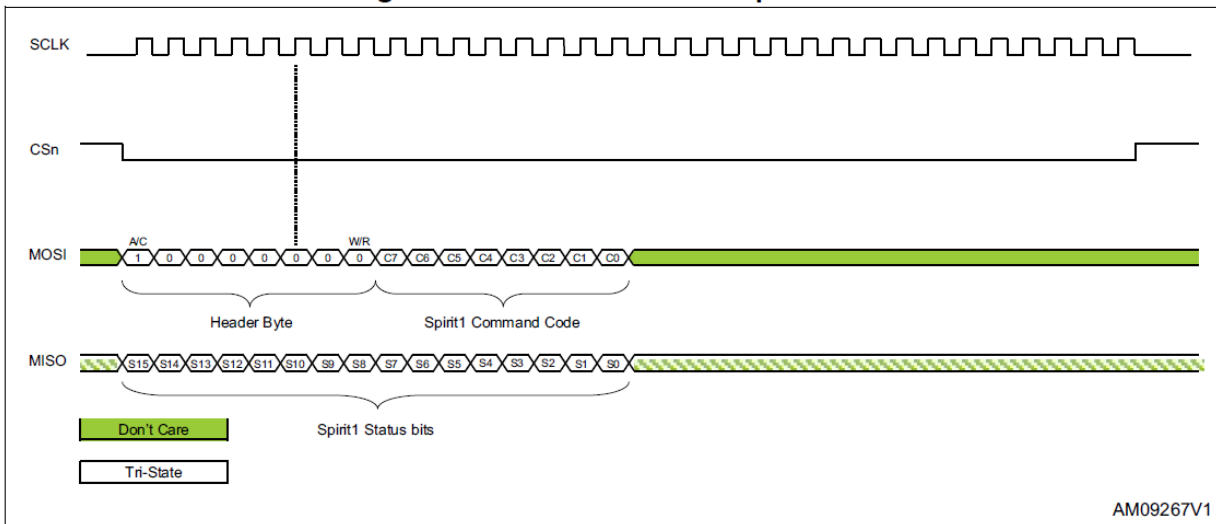

Figure 7 Module SPI Write Command Timing

4.3 Precautions for Use

To ensure that the RF performance of the module is as effective as possible in its application, users should obey the following principles in use:

1. It is recommended to use DC regulated power supply to power the module, the ripple coefficient of the power supply should be as small as possible, the module should be reliably grounded, and please pay attention to the correct connection of positive and negative power supply. If it is reversed, it may cause permanent damage to the module;
2. the module is recommended to be placed in the open edge of the base plate, the antenna

interface should face outward, and the antenna part needs to do 50 ohm impedance control.

3. It is best not to have metal devices near the antenna, otherwise the communication distance of the module will be shortened to different degrees in different environments.

DRAFT

Chapter V: Reflow Soldering Operation Instruction

作业指导书 Standard Operation Procedure (SOP)				批准	审核	作成	作成日																																												
生产工段 Station	SMT		工序名 Station	回流焊																																															
	文件编号 Doc No.	MSOP-FL-RX1060N-G12	版本 Rev	A3	程序名 Program			001-RR-T-S606-S4																																											
<p>曲线图</p>																																																			
<table border="1"> <thead> <tr> <th>温区</th> <th>1</th> <th>2</th> <th>3</th> <th>4</th> <th>5</th> <th>6</th> <th>7</th> <th>8</th> <th>9</th> <th>10</th> </tr> </thead> <tbody> <tr> <td>Top</td> <td>150</td> <td>150</td> <td>180</td> <td>180</td> <td>180</td> <td>195</td> <td>210±5</td> <td>240±5</td> <td>255±5</td> <td>245±5</td> </tr> <tr> <td>Bottom</td> <td>150</td> <td>150</td> <td>180</td> <td>180</td> <td>180</td> <td>195</td> <td>210±5</td> <td>240±5</td> <td>255±5</td> <td>245±5</td> </tr> <tr> <td>Conveyor speed</td> <td colspan="2">900±50 mm/min</td> <td colspan="2">风机转速</td> <td>2000-3500 r/min</td> <td colspan="5"></td> </tr> </tbody> </table>								温区	1	2	3	4	5	6	7	8	9	10	Top	150	150	180	180	180	195	210±5	240±5	255±5	245±5	Bottom	150	150	180	180	180	195	210±5	240±5	255±5	245±5	Conveyor speed	900±50 mm/min		风机转速		2000-3500 r/min					
温区	1	2	3	4	5	6	7	8	9	10																																									
Top	150	150	180	180	180	195	210±5	240±5	255±5	245±5																																									
Bottom	150	150	180	180	180	195	210±5	240±5	255±5	245±5																																									
Conveyor speed	900±50 mm/min		风机转速		2000-3500 r/min																																														
<table border="1"> <thead> <tr> <th>参数</th> <th>峰值温度</th> <th>浸温</th> <th>预热温度</th> <th>上升斜率</th> <th>降温斜率</th> </tr> </thead> <tbody> <tr> <td>Temp Range</td> <td>240±5</td> <td>150-180</td> <td>217</td> <td>25-150</td> <td></td> </tr> <tr> <td>Time</td> <td></td> <td>60-120S</td> <td>45-90S</td> <td>1-3 °C/s</td> <td>≤4°C/s</td> </tr> </tbody> </table>								参数	峰值温度	浸温	预热温度	上升斜率	降温斜率	Temp Range	240±5	150-180	217	25-150		Time		60-120S	45-90S	1-3 °C/s	≤4°C/s																										
参数	峰值温度	浸温	预热温度	上升斜率	降温斜率																																														
Temp Range	240±5	150-180	217	25-150																																															
Time		60-120S	45-90S	1-3 °C/s	≤4°C/s																																														
<table border="1"> <thead> <tr> <th>物料名称 Description</th> <th>规格</th> <th>料号 P/N</th> <th>位号 Location</th> <th>工具/设备</th> <th>用量 (PCS)</th> <th>日期</th> <th>变更历史</th> </tr> </thead> <tbody> <tr> <td>1</td> <td></td> <td></td> <td></td> <td>测温仪</td> <td>1</td> <td></td> <td>对设定温度和链速增加允许范围</td> </tr> <tr> <td>2</td> <td></td> <td></td> <td></td> <td>测温板</td> <td>1</td> <td></td> <td>曲线参数中删除回焊速率</td> </tr> <tr> <td>3</td> <td></td> <td></td> <td></td> <td>耐高温手套</td> <td>1</td> <td></td> <td></td> </tr> </tbody> </table>								物料名称 Description	规格	料号 P/N	位号 Location	工具/设备	用量 (PCS)	日期	变更历史	1				测温仪	1		对设定温度和链速增加允许范围	2				测温板	1		曲线参数中删除回焊速率	3				耐高温手套	1														
物料名称 Description	规格	料号 P/N	位号 Location	工具/设备	用量 (PCS)	日期	变更历史																																												
1				测温仪	1		对设定温度和链速增加允许范围																																												
2				测温板	1		曲线参数中删除回焊速率																																												
3				耐高温手套	1																																														

Notes to Users

- 1、 Welcome to use the products of Lierda Science & Technology Group Co., Ltd. Before using our products, please read this respectful notice. If you have started using it, you have read and accepted this respectful notice.
- 2、 Lierda Science & Technology Group Co., Ltd. reserves the right of final interpretation and modification of all information provided and is subject to change without notice.

Prepared by: Lierda Science & Technology
Group Co., Ltd.
Microcontroller Business Division
Sep. 2018

Conformity

FCC regulatory conformance :

This device complies with Part 15 of the FCC Rules. Operation is subject to the following two conditions:

- (1) This device may not cause harmful interference.
- (2) This device must accept any interference received, including interference that may cause undesired operation.

NOTE: This equipment has been tested and found to comply with the limits for a Class B digital device, pursuant to part 15 of the FCC Rules. These limits are designed to provide reasonable protection against harmful interference in a residential installation.

This equipment generates uses and can radiate radio frequency energy and, if not installed and used in accordance with the instructions, may cause harmful interference to radio communications. However, there is no guarantee that interference will not occur in a particular installation. If this equipment does cause harmful interference to radio or television reception, which can be determined by turning the equipment off and on, the user is encouraged to try to correct the interference by one or more of the following measures:

- Reorient or relocate the receiving antenna.
- Increase the separation between the equipment and receiver.
- Connect the equipment into an outlet on a circuit different from that to which the receiver is connected.
- Consult the dealer or an experienced radio/TV technician for help

NOTE: The manufacturer is not responsible for any radio or TV interference caused by unauthorized modifications to this equipment. Such modifications could void the user's authority to operate the equipment.

FCC Radiation Exposure Statement:

This equipment complies with FCC radiation exposure limits set forth for an uncontrolled environment.

ORIGINAL EQUIPMENT MANUFACTURER (OEM) NOTES

The OEM must certify the final end product to comply with unintentional radiators (FCC Sections 15.107 and 15.109) before declaring compliance of the final product to Part 15 of the FCC rules and regulations. Integration into devices that are directly or indirectly connected to AC lines must add with Class II Permissive Change.

The OEM must comply with the FCC labeling requirements. If the module's label is not visible when installed, then an additional permanent label must be applied on the outside of the finished product which states: "Contains transmitter module FCC ID: 4CQHFNUF3THUV655O22". Additionally, the following statement should be included on the label and in the final product's user manual: "This device complies with Part 15 of the FCC Rules. Operation is subject to the following two conditions:

- (1) This device may not cause harmful interferences, and
- (2) this device must accept any interference received, including interference that may cause undesired operation."

The module is limited to installation in mobile or fixed applications. Separate approval is required for all other operating configurations, including portable configuration with respect to Part 2.1093 and different antenna configurations.

A module or modules can only be used without additional authorizations if they have been tested and granted under the same intended end - use operational conditions, including simultaneous transmission operations. When they have not been tested and granted in this manner, additional testing and/or FCC application filing may be required. The most straightforward approach to address additional testing conditions is to have the grantee responsible for the certification of at least one of the modules submit a permissive change application. When having a module grantee file a permissive change is not practical or feasible, the following guidance provides some additional options for host manufacturers. Integrations using modules where additional testing and/or FCC application filing(s) may be required are: (A) a module used in devices requiring additional RF exposure compliance information (e.g., MPE evaluation or SAR testing); (B) limited and/or split modules not meeting all of the module requirements; and (C) simultaneous transmissions for independent collocated transmitters not previously granted together.

This Module is full modular approval, it is limited to OEM installation ONLY.

Integration into devices that are directly or indirectly connected to AC lines must add with Class II Permissive Change. (OEM) Integrator has to assure compliance of the entire end product include the integrated Module. Additional measurements (15B) and/or equipment authorizations (e.g. Verification) may need to be addressed depending on co-location or simultaneous transmission issues if applicable. (OEM) Integrator is reminded to assure that these installation instructions will not be made available to the end user

Requirement per KDB996369 D03

2.2 List of applicable FCC rules

List the FCC rules that are applicable to the modular transmitter. These are the rules that specifically establish the bands of operation, the power, spurious emissions, and operating fundamental frequencies. DO NOT list compliance to unintentional-radiator rules (Part 15 Subpart B) since that is not a condition of a module grant that is extended to a host manufacturer. See also Section 2.10 below concerning the need to notify host manufacturers that further testing is required.³

Explanation: This module meets the requirements of FCC part 15C(15.231).

2.3 Summarize the specific operational use conditions

Describe use conditions that are applicable to the modular transmitter, including for example any limits on antennas, etc. For example, if point-to-point antennas are used that require reduction in power or compensation for cable loss, then this information must be in the instructions. If the use condition limitations extend to professional users, then instructions must state that this information also extends to the host manufacturer's instruction manual. In addition, certain information may also be needed, such as peak gain per frequency band and minimum gain, specifically for master devices in 5 GHz DFS bands.

Explanation: The EUT has a spring antenna, and the antenna use a permanently attached antenna which is not replaceable.

2.4 Limited module procedures

If a modular transmitter is approved as a "limited module," then the module manufacturer is responsible for approving the host environment that the limited module is used with. The manufacturer of a limited module must describe, both in the filing and in the installation instructions, the alternative means that the limited module manufacturer uses to verify that the host meets the necessary requirements to satisfy the module limiting conditions.

A limited module manufacturer has the flexibility to define its alternative method to address the conditions that limit the initial approval, such as: shielding, minimum signaling amplitude, buffered modulation/data inputs, or power supply regulation. The alternative method could include that the limited module manufacturer reviews detailed test data or host designs prior to giving the host manufacturer approval.

This limited module procedure is also applicable for RF exposure evaluation when it is necessary to demonstrate compliance in a specific host. The module manufacturer must state how control of the product into which the modular transmitter will be installed will be maintained such that full compliance of the product is always ensured. For additional hosts other than the specific host originally granted with a limited module, a Class II permissive change is required on the module grant to register the additional host as a specific host also approved with the module.

Explanation: The module is not a limited module.

2.5 Trace antenna designs

For a modular transmitter with trace antenna designs, see the guidance in Question 11 of KDB Publication 996369 D02 FAQ – Modules for Micro-Strip Antennas and traces. The integration information shall include for the TCB review the integration instructions for the following aspects:

layout of trace design, parts list (BOM), antenna, connectors, and isolation requirements.

- a) Information that includes permitted variances (e.g., trace boundary limits, thickness, length, width, shape(s), dielectric constant, and impedance as applicable for each type of antenna);
- b) Each design shall be considered a different type (e.g., antenna length in multiple(s) of frequency, the wavelength, and antenna shape (traces in phase) can affect antenna gain and must be considered);
- c) The parameters shall be provided in a manner permitting host manufacturers to design the printed circuit (PC) board layout;
- d) Appropriate parts by manufacturer and specifications;
- e) Test procedures for design verification; and
- f) Production test procedures for ensuring compliance.

The module grantee shall provide a notice that any deviation(s) from the defined parameters of the antenna trace, as described by the instructions, require that the host product manufacturer must notify the module grantee that they wish to change the antenna trace design. In this case, a Class II permissive change application is required to be filed by the grantee, or the host manufacturer can take responsibility through the change in FCC ID (new application) procedure followed by a Class II permissive change application.

Explanation: Yes, The module with trace antenna designs, and This manual has been shown the layout of trace design, antenna, connectors, and isolation requirements.

2.6 RF exposure considerations

It is essential for module grantees to clearly and explicitly state the RF exposure conditions that permit a host product manufacturer to use the module. Two types of instructions are required for RF exposure information: (1) to the host product manufacturer, to define the application conditions (mobile, portable – xx cm from a person's body); and (2) additional text needed for the host product manufacturer to provide to end users in their end-product manuals. If RF exposure statements and use conditions are not provided, then the host product manufacturer is required to take responsibility of the module through a change in FCC ID (new application).

Explanation: This module complies with FCC RF radiation exposure limits set forth for an uncontrolled environment. This module is designed to comply with the FCC statement, FCC ID is:2AOFDLS1RFST433M00.

2.7 Antennas

A list of antennas included in the application for certification must be provided in the instructions. For modular transmitters approved as limited modules, all applicable professional installer instructions must be included as part of the information to the host product manufacturer. The antenna list shall also identify the antenna types (monopole, PIFA, dipole, etc. (note that for example an “omni-directional antenna” is not considered to be a specific “antenna type”)).

For situations where the host product manufacturer is responsible for an external connector, for example with an RF pin and antenna trace design, the integration instructions shall inform the installer that unique antenna connector must be used on the Part 15 authorized transmitters used in the host product. The module manufacturers shall provide a list of acceptable unique connectors.

Explanation: The EUT has a spring Antenna, and the antenna use a permanently attached antenna which is unique.

2.8 Label and compliance information

Grantees are responsible for the continued compliance of their modules to the FCC rules. This includes advising host product manufacturers that they need to provide a physical or e-label stating “Contains FCC ID” with their finished product. See Guidelines for Labeling and User Information for RF Devices – KDB Publication 784748.

Explanation:The host system using this module, should have label in a visible area indicated the following texts: “Contains FCC ID: 2AOFDLS1RFST433M00”

2.9 Information on test modes and additional testing requirements

Additional guidance for testing host products is given in KDB Publication 996369 D04 Module Integration Guide. Test modes should take into consideration different operational conditions for a stand-alone modular transmitter in a host, as well as for multiple simultaneously transmitting modules or other transmitters in a host product.

The grantee should provide information on how to configure test modes for host product evaluation for different operational conditions for a stand-alone modular transmitter in a host, versus with multiple, simultaneously transmitting modules or other transmitters in a host.

Grantees can increase the utility of their modular transmitters by providing special means, modes, or instructions that simulates or characterizes a connection by enabling a transmitter. This can greatly simplify a host manufacturer’s determination that a module as installed in a host complies with FCC requirements.

Explanation: Top band can increase the utility of our modular transmitters by providing instructions that simulates or characterizes a connection by enabling a transmitter.

2.10 Additional testing, Part 15 Subpart B disclaimer

The grantee should include a statement that the modular transmitter is only FCC authorized for the specific rule parts (i.e., FCC transmitter rules) listed on the grant, and that the host product manufacturer is responsible for compliance to any other FCC rules that apply to the host not covered by the modular transmitter grant of certification. If the grantee markets their product as being Part 15 Subpart B compliant (when it also contains unintentional-radiator digital circuitry), then the grantee shall provide a notice stating that the final host product still requires Part 15 Subpart B compliance testing with the modular transmitter installed.

Explanation: The module without unintentional-radiator digital circuitry, so the module does not require an evaluation by FCC Part 15 Subpart B. The host should be evaluated by the FCC Subpart B.