

802.15.4/Zigbee Module Datasheet

REX3B

V2.0.2

Contents

1. Product Description.....	- 2 -
1.1 Product Introduction.....	- 2 -
1.2 Product Applications.....	- 4 -
1.3 Main Features	- 4 -
1.4 Product Advantages.....	- 5 -
1.5 Name Abbreviations	- 6 -
1.6 Related Documents	- 6 -
2. Product Description.....	- 7 -
2.1 Description.....	- 7 -
3. Technical Specifications	- 8 -
3.1. Electrical Character	- 8 -
3.2. Physical/Environmental Character.....	- 10 -
3.3. Pin Configuration.....	- 10 -
3.4 Antenna Specification.....	- 13 -
3.5. RF Performance Test Results	- 14 -
4. Ordering Information.....	- 16 -
5. Contact Us.....	- 17 -

1. Product Description

1.1 Product Introduction

REX3B is a small, high-sensitivity low-power ZigBee module. Based on the latest EFR32 platform from Silabs, the module complies with the IEEE 802.15.4 specification and the ZigBee 3.0 protocol standard. It has been widely used in smart home, building automation, industrial monitoring and other fields. Using this module saves a lot of time effort and cost for the user's development.

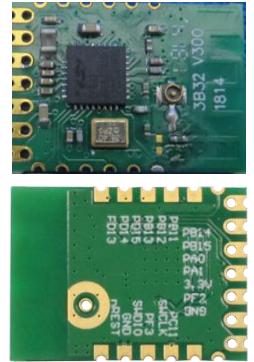

This device complies with part 15 of the FCC Rules. Operation is subject to the following two conditions:

- (1) This device may not cause harmful interference, and*
- (2) this device must accept any interference received, including interference that may cause undesired operation.*

Please note that changes or modifications not expressly approved by the party responsible for compliance could void the user's authority to operate the equipment.

Note: This equipment has been tested and found to comply with the limits for a Class B digital device, pursuant to part 15 of the FCC Rules. These limits are designed to provide reasonable protection against harmful interference in a residential installation. This equipment generates, uses and can radiate radio frequency energy and, if not installed and used in accordance with the instructions, may cause harmful interference to radio communications. However, there is no guarantee that interference will not occur in a particular installation. If this equipment does cause harmful interference to radio or television reception, which can be determined by turning the equipment off and on, the user is encouraged to try to correct the interference by one or more of the following measures:

- Reorient or relocate the receiving antenna.*
- Increase the separation between the equipment and receiver.*
- Connect the equipment into an outlet on a circuit different from that to which the receiver is connected.*
- Consult the dealer or an experienced radio/TV technician for help.*

This module is a limited single-modular transmitter without shielding case, this module must be used in the specific host(s) and the applicable operating conditions in which the shielding case is provided by the host(s), the host(s) must be a mobile device. The shielding design must fully enfold the RF circuitry - that includes shielding the top, all sides, and the bottom. The bottom is a shielding ground plane, and must be expressly designed as an effective shield made of materials such as sheet metal, metal mesh, or a metallic ink coated material. Any holes in the shield must be significantly smaller than the wavelength of the radiation that is being blocked, to effectively approximate an unbroken conducting surface.

When the host manufacturer is using this module, they must comply with all the requirements-of-use as described above. Only the module grantee can make the test evaluation that the module is compliant in the host.

When the host manufacturer cannot comply, or is not given clear direction(s) to address the limitation(s), the only procedure available to the host manufacturer is to have the module grantee approve the use of the module through either Class II permissive change under the existing FCC ID and IC ID or the host manufacturer may file a Change in ID application, or use a new FCC ID. Only the module grantee can make the test evaluation that the module is compliant in the host. When the module grantee either refuses to make this evaluation, or does not think it is necessary, the module certification is rendered invalid for use in the host, and the host manufacturer has no choice other than to use a different module, or take responsibility (§ 2.929) and obtain a new FCC ID and IC ID for the product.

This device complies with Industry Canada's licence-exempt RSSs. Operation is subject to the following two conditions:

- (1) This device may not cause interference; and*
- (2) This device must accept any interference, including interference that may cause undesired operation of the device.*

Le présent appareil est conforme aux CNR d'Industrie Canada applicables aux appareils radio exempts de licence. L'exploitation est autorisée aux deux conditions suivantes:

- (1) l'appareil ne doit pas produire de brouillage;*
- (2) l'utilisateur de l'appareil doit accepter tout brouillage radioélectrique subi, même si le brouillage est susceptible d'en compromettre le fonctionnement.*

This equipment complies with radio frequency exposure limits set forth by the Innovation, Science and Economic Development Canada for an uncontrolled environment.

*This equipment must be installed and operated with a minimum distance of **20 cm** between the device and the user or bystanders.*

This device must not be co-located or operating in conjunction with any other antenna or transmitter.

Cet équipement est conforme aux limites d'exposition aux radiofréquences définies par la Innovation, Sciences et Développement économique Canada pour un environnement non contrôlé.

Cet équipement doit être installé et utilisé avec un minimum de 20 cm de distance entre le dispositif et l'utilisateur ou des tiers.

Ce dispositif ne doit pas être utilisé à proximité d'une autre antenne ou d'un autre émetteur.

FCC ID: 2AOE2REX3B

IC ID: 22670-REX3B

HVIN: REX3B

Host labeling requirement: Contains FCC ID: 2AOE2REX3B

Host labeling requirement: Contains IC: 22670-REX3B

The module is a limited single module without shielding case, CIIPC or new filing shall be applied for any host equipment using this module

1.2 Product Applications

The REX3B module complies with the IEEE 802.15.4 specification and the ZigBee 3.0 protocol standard, supports self-healing, self-organizing mesh networks, optimizes network traffic, and reduces power consumption. This module supports the following application configurations:

- Standard ZigBee 3.0 features
- Transparent transmission: Users can perform program development according to our AT command procedure
- Customization: Reliable and safe customized applications based on customers specific requirements

Module applications include but are not limited to:

- Smart Home
 - Lighting Control
 - Security System
 - Air Quality Testing
 - Door Lock
 - Electric curtains
 - Air Conditioning, Floor Heating, Fresh Air Control
 - Scene Automation
- Building Automation and Monitoring
- HVAC monitoring and control
- Inventory Management
- Smart Agriculture
- Industrial Monitoring
- Smart Traffic
- Automatical Meter Reading

1.3 Main Features

- Dimension : 20.4*14.8*1.8mm
- Output Power: Up to 19.5dBm

- High receiver sensitivity: up to -100dBm
- Excellent link budget: up to 119.5dBm
- Reliable communication range: 2000m (view of sight distance)
- A variety of antenna options
- Extremely low power consumption
 - Sleep Mode: <2.8μA
 - Receive Mode: 12mA
 - Launch Mode : 107mA@19dBm
- Rich storage resources:
 - 256K byte Flash ; 32K byte RAM
- 15 GPIOs can be configured for various functional interfaces according to user needs
 - GPIO
 - External interrupt source
 - 12-bit precision ADC sampling channel
 - USART with Hardware Flow Control
 - TWI Interface
 - SPI/I²C Interface
 - PWM Output
 - Hardware watchdog

1.4 Product Advantages

- Small footprint can be used in very small devices.
- Industry-leading link budget
- Excellent battery life
- Rich storage resources for customer software applications
- Mesh networking capability
- Easy-to-use, low-cost development kit
- ISM license-free band

1.5 Name Abbreviations

ADC	Analog-to -Digital Converter
GPIO	General Purpose Input/Output
HVAC	Heating, Ventilating and Air Conditioning
TWI	Inter-Integrated Circuit
IEEE	Institute of Electrical and Electronics Engineers
ISM	Industrial, Scientific and Medical radio band
JTAG	Digital interface for debugging of embedded device, also known as IEEE 1149.1 standard interface
MAC	Medium Access Control layer
PCB	Printed Circuit Board
RAM	Random Access Memory
RF	Radio Frequency
RTS/CTS	Request to Send/ Clear to Send
RX	Receiver
SMA	Surface Mount Assembly
SPI	Serial Peripheral Interface
TX	Transmitter
UART	Universal Asynchronous Receiver/Transmitter
ZigBeePRO	Wireless networking standards targeted at low-power applications

1.6 Related Documents

[1] ZigBee 3.0 – The Open, Global Standard for the Internet of Things December 2, 2014

2. Product Description

2.1 Description

REX3B is a compact, high-sensitivity low-power ZigBee module that complies with the IEEE 802.15.4 specification and the ZigBee 3.0 protocol standard. Based on the latest EFR32 platform from US Silabs, it has extremely excellent RF performance, extremely low power consumption, powerful processor and abundant on-chip resources, and it is very easy for user integration.

Figure 2-1. Chart

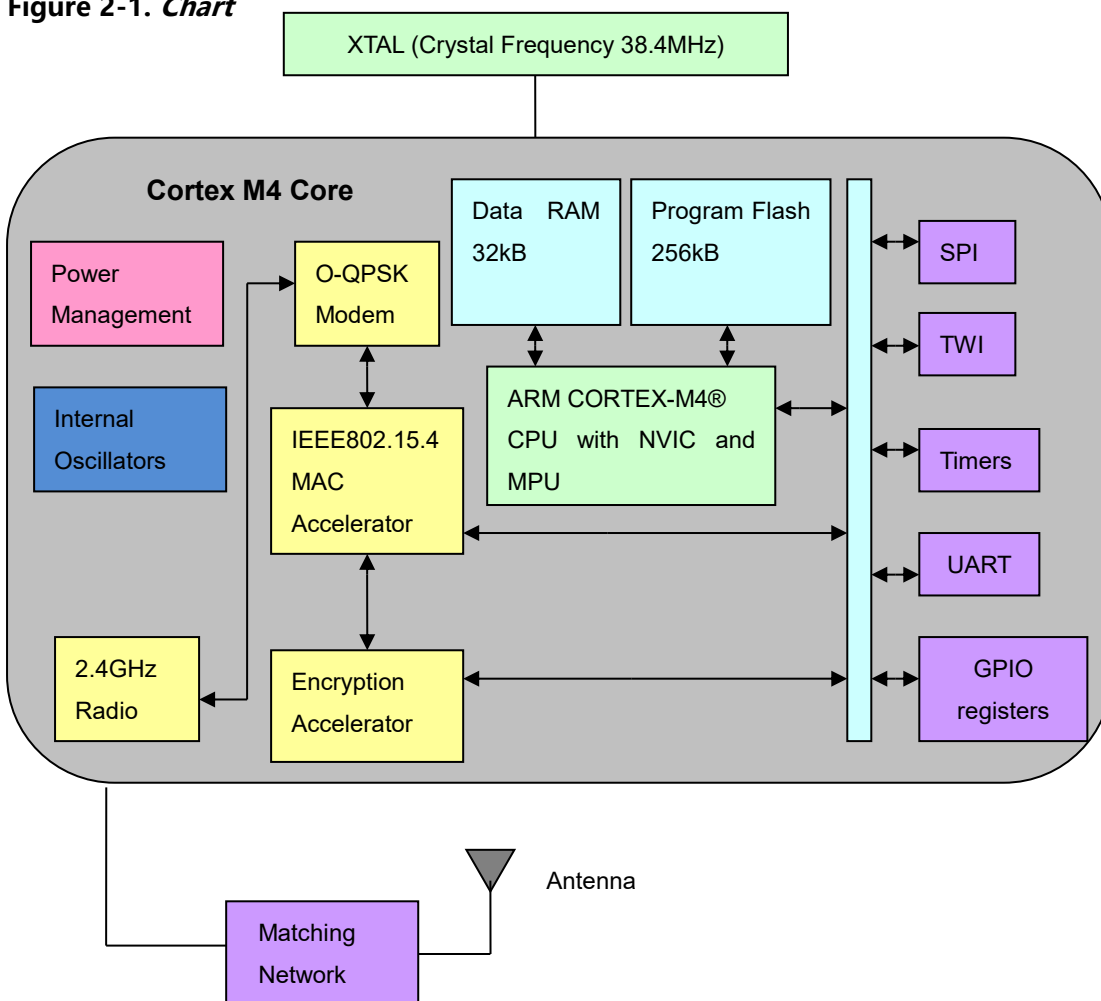

The REX3B module complies with the FCC, IC, and CE specifications and can be used in a variety of devices in different environments. Moreover, the module is RoHS compliant.

There are 2 types of Oscillator source on the REX3B module:

- 1) Crystal Oscillator out side of chip, 38.4MHz
- 2) Oscillator inside of the EFR32MG RF chip, includes:
 - a) A high frequency RC Oscillator for MCU system
 - b) A high frequency RC Oscillator for peripheral such ADC
 - c) A 32.768KHz low frequency RC Oscillator for real time counter
 - d) A 1KHz low frequency RC Oscillator for sleepy timer

3. Technical Specifications

3.1. Electrical Character

3.1.1. Electrical Character

Table 3-1. Absolute maximum rated parameter

Parameter	Min.	Max.
Module supply voltage range (VCC)	1.85V	3.8V
Pin Operating Voltage Range (Except ADC Pin)	-0.3V	VDD_PADS+0.3
ADC pin operating voltage range	-0.3V	2.1V
All I/O maximum drive current data of the chip		50 mA
The maximum received RF signal strength of the chip		+10 dBm

Note: Exceeding the absolute maximum rating may damage the module. In no case can the user violate the absolute maximum ratings listed in the table above. Any violation may cause irreparable damage to the module.

3.1.2. Test Condition

Table 3-2. Test Condition (Unless seperately agreement), VCC = 3.3V, Temp. = 25°C

Parameter	Range	Unit
Receive Current	12	mA
Emission Current (@19dBm)	107	mA
Sleep Current	2.8	μA
Transmit Power	-9 to +19.5	dBm
Receiver Sensitivity (90%)	-98 to -100	dBm

3.1.3. Radio Frequency Character

Table 3-3. RF Character

Parameter	Test Condition	Range	Unit
Working Frequency		2400~2483.5	MHz
Bands Number		16	
Channel Number		0B~1A	Hex
Channel Spacing		5	MHz
Transmit Power		-9 to +19.5	dBm
Receiver Sensitivity (90%)		-98 to -100	dBm
Max. Transmission Rate		250	kbps
Rated Input/Output Impedance	For unbalanced output	50	Ω

3.1.4. Processor Features

Table 3-4.Processor Features

Parameter	Test Condition	Range	Unit
On-chip Flash memory		256K	bytes
On-chip RAM memory		32K	bytes
Work Frequency		38.4	MHz

3.1.5. Module Interface Features

Table 3-5. Module Interface Features

Parameter	Test Condition	Range	Unit
UART maximum baud rate		230400	bps
Analog channel resolution/conversion time	Half duplex mode	12/4096	Bits/ μ s
Analog input impedance		>1	M Ω
Analog reference voltage (VREF)		1.2	V
Analog input voltage		0 - VREF	V
I2C Bus maximum clock frequency		400	KHz
GPIO output voltage (logic 0)	-8/ 4 mA	0 ~ 0.18*VCC	V
GPIO output voltage (logic 1)	-8/ 4 mA	0.82*VCC ~ VCC	V
Real-time clock frequency		32.768	KHz

3.2. Physical/Environmental Character

Table 3-6. Physical/Environmental Character

Parameter	Value	Note
Dimension	20.4*14.8*1.8mm	
Weight	<1g	
Working Temperature	-40°C to +85°C (default) -40°C to +115°C (Industrial grade)	
Relative Humidity	<95%	

3.3. Pin Configuration

Figure 3-1. Appearance Size Diagram

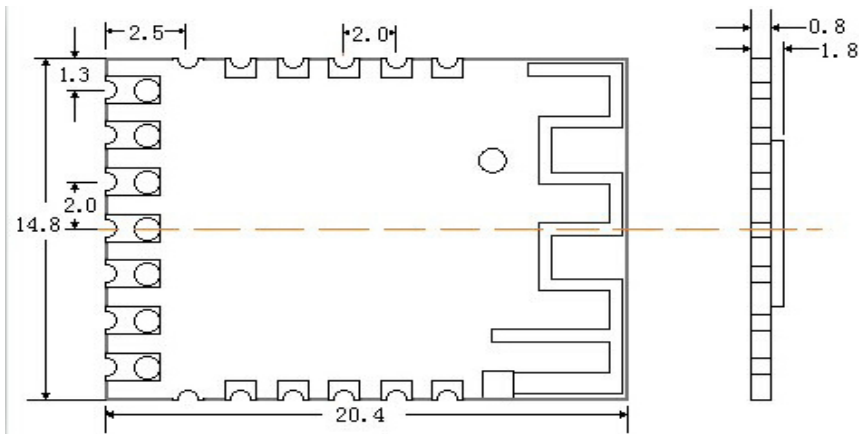

Figure 3-2. Product Package

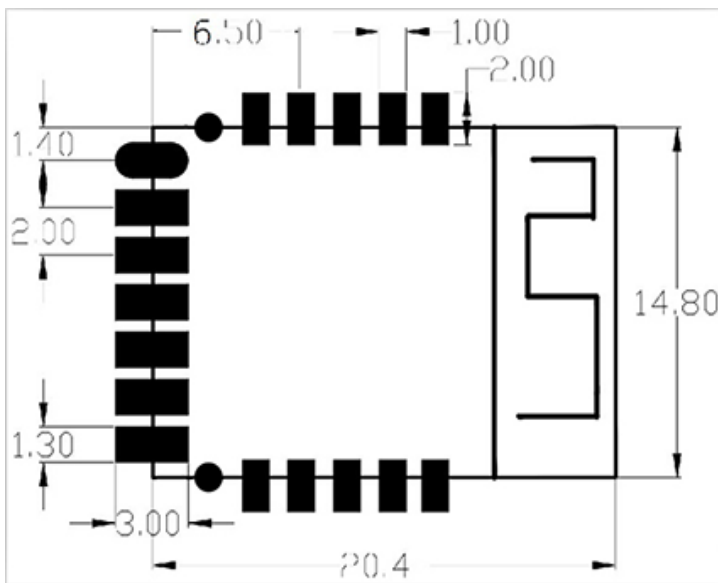

Figure 3-3. Pin Configuration

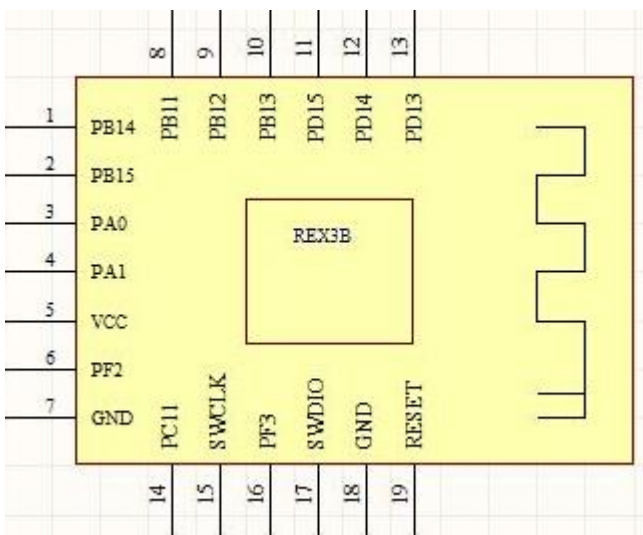

Table 3-7. Pin Description

Module pin number	QFN32P ackage pin number	Pin Signal	Direction	Pin Description
1	23	PB14	I/O	GPIO
2	24	PB15	I/O	GPIO
3	17	PA0	I/O	GPIO;TXD
4	18	PA1	I/O	GPIO;RXD
5	5,22,28,30	3.3V	I	VCC
6	3	PF2	I/O	GPIO
7	9,10,25	GND	I	GND
8	19	PB11	I/O	GPIO
9	20	PB12	I/O	GPIO
10	21	PB13	I/O	GPIO
11	16	PD15	I/O	GPIO;PTA_REQUEST
12	15	PD14	I/O	GPIO;PTA_GRANT
13	14	PD13	I/O	GPIO;PTA_PRIORITY
14	32	PC11	I/O	GPIO
15	1	PF0	IO	GPIO; SWCLK
16	4	PF3	IO	GPIO
17	2	PF1	IO	GPIO; SWDIO
18	9,10,25	GND	I	GND
19	8	RESET	I	RESET

3.4 Antenna Specification

Multiple antenna interfaces have been integrated on the REX3B module. As shown below

3.4.1 PCB Antenna

Figure 3-4. PCB Antenna



When using the PCB antenna output, note the following points:

1. Avoid placing the module inside a metal enclosure.
2. Avoid placing metal objects close to the PCB antenna (at least 1cm away, it is recommended to be 2.7cm or more).
3. Do not place the module next to devices emitting electromagnetic radiation, such as transformers.

The user circuit board should be designed to prevent its components, traces, or floors from interfering with the PCB antenna of the wireless module. The basic principle is:

- Do not trace, lay or place other components around the PCB antenna
- The PCB antenna preferably protrudes from the PCB board
- Do not use metal housing around PCB antenna

Figure 3-5. PCB layout diagram for module antenna position selection

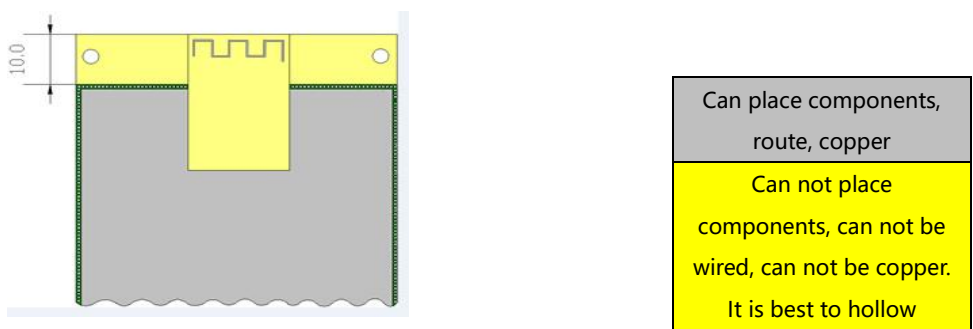

3.5. RF Performance Test Results

Figure 3-17. Receiver Sensitivity

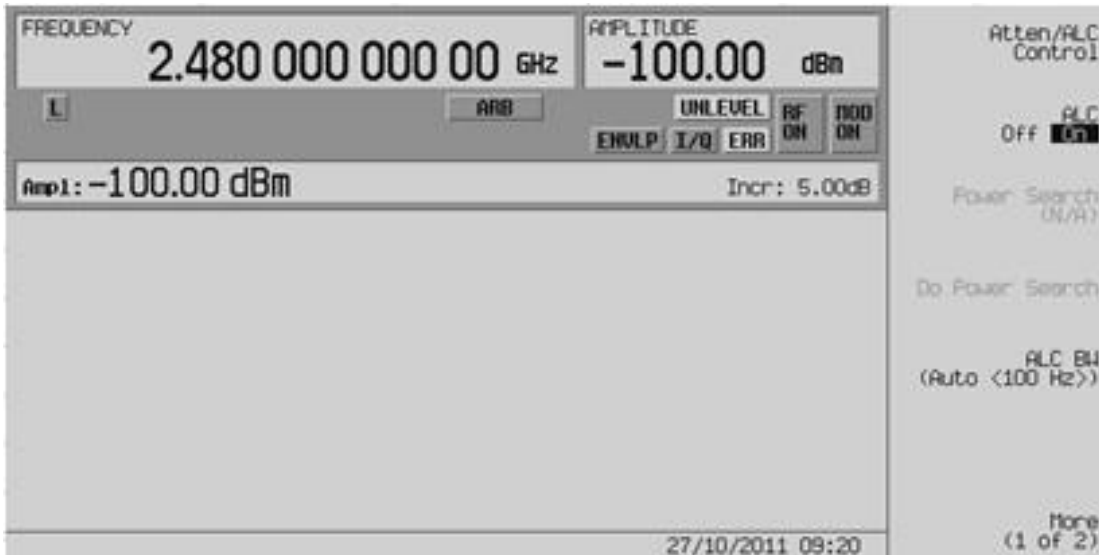

Figure 3-18. Carrier Signal Test

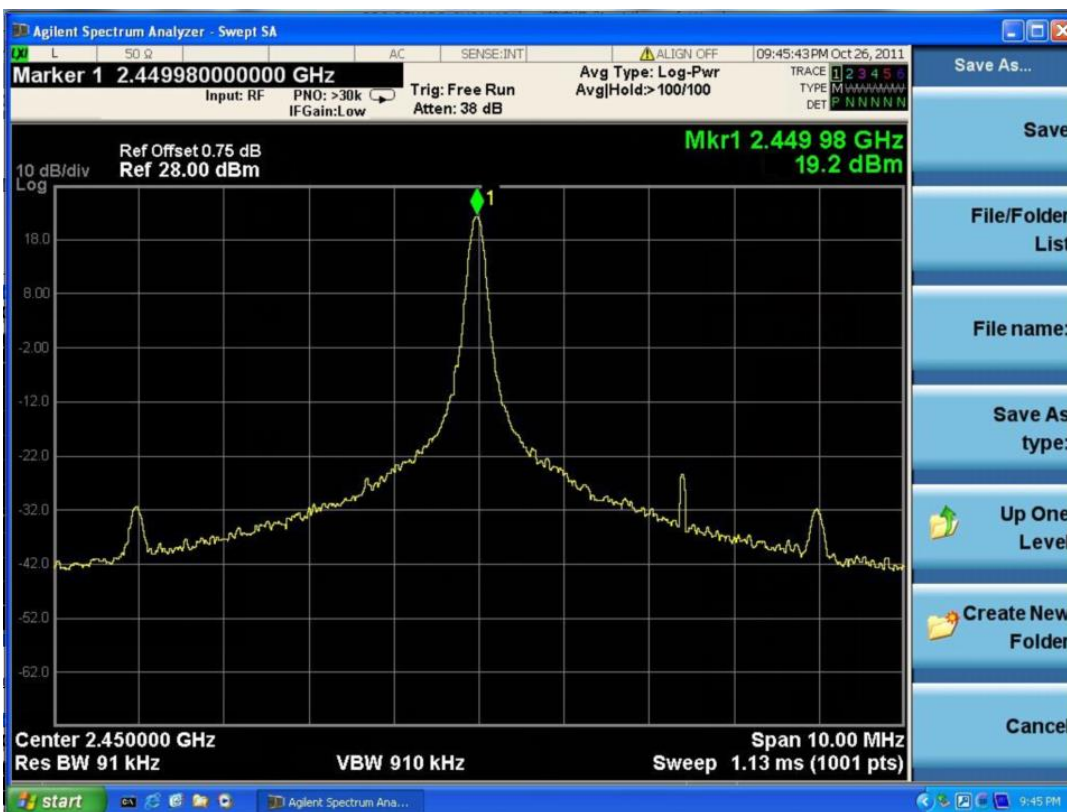

Figure 3-19. Modulation Signal Test



4. Ordering Information

Manufacturer

REX=REXENSE

REX 3 B 01 B 32 B - I

Series

3=Zigbee Series

Package Type

M=Ultra-Small Module

B =Lighting Field Module

D =DIP

S =SMD

Chip

01=EFR32MG1 Series

12=EFR32MG12 Series

13=EFR32MG13 Series

Power Output

P=19dbm

B=16.5dBm

V=13.5dBm

Chip

32 = EFR32(32 Pins)

48 = EFR32(48 Pins)

57 = EM357

585 = EM3585

Antenna

P=Pinout

B=PCB Antenna (default)

Industrial Grade

I=Industrial Grade

5. Contact Us

Zhejiang Raying IoT Technology Co., Ltd.

Add: 10F,North of Building No.10,Wellong Science & Technology Park,
No.88 Jiangling Road,Binjiang District,Hangzhou,310051 China

T: +86-571-85395623

F: +86-571-87987620

Email: intl@rexense.com

Web: www.rexense.com