

Instruction Manual for enSkate

EK-FIB01-AS01

I. WARNINGS



Do not use enSkate Fiboard until you read and thoroughly understand the owner's manual. It contains information that is critical to your safety.



enSkate is not liable for any damage or injury caused by unsafe usage or faulty repair. Any repairs made to this product by unauthorized technicians are the sole responsibility of the owner.



Fiboard is only for people 16 years and older.



While riding Fiboard, always wear protective gear, including knee, elbow, and wrist guards and an approved safety helmet, when riding Fiboard.



Only use Fiboard on paved surfaces or on gentle slopes. Do not use on dirt, sand, steep slopes, or slippery surfaces. Be cautious when going down hills.

II. Introduction to Fiboard

2-1 Schematic diagram and description of Fiboard

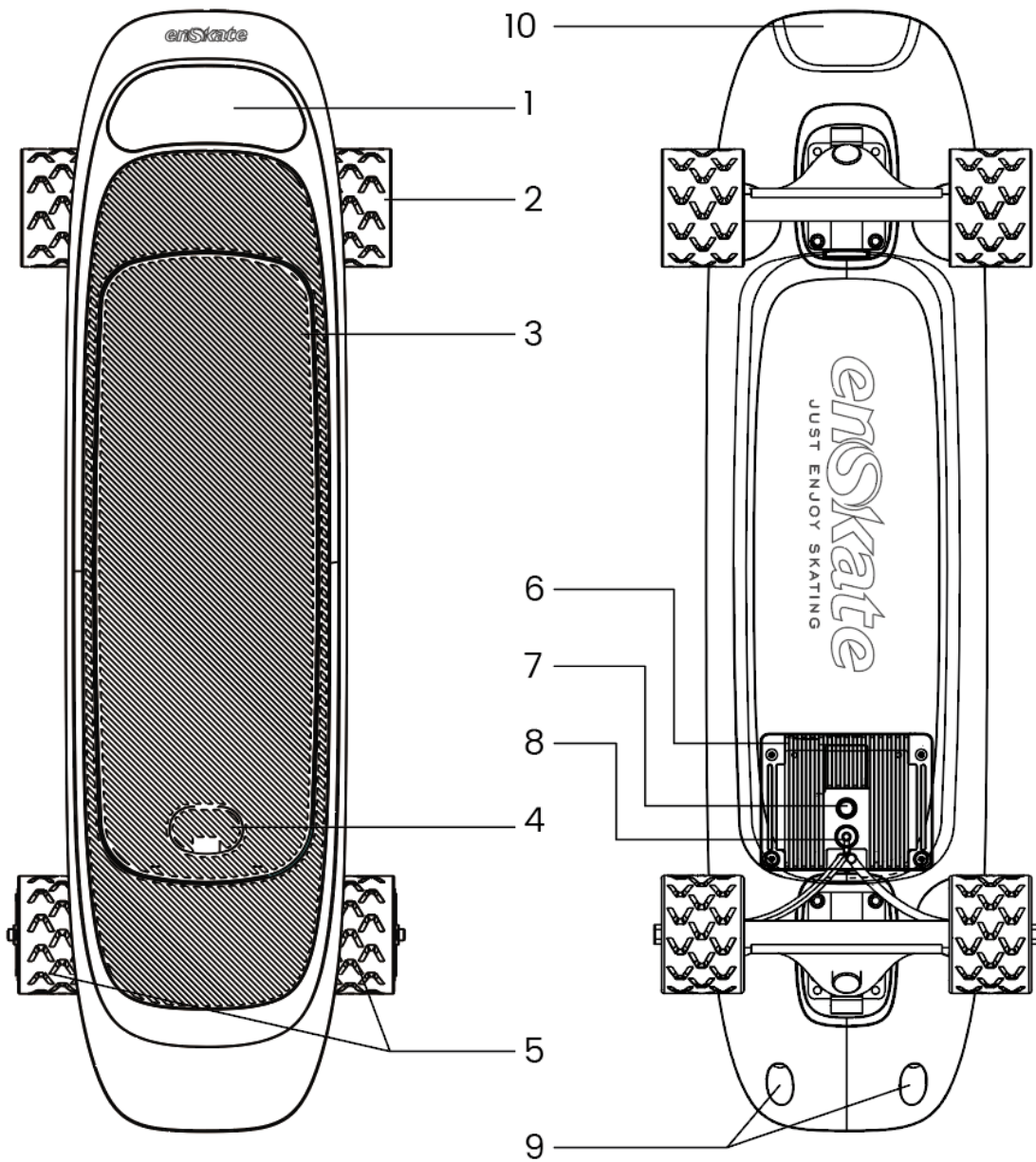

(Figure 1)

① Description of identifiers on the display screen:



(Figure 2)



Front light indicator. Turn on the front light of the Fiboard, and the identifier appears;



Rear warning light indicator. Turn on the rear warning light of the Fiboard, and the identifier appears;

88.8 km Riding mileage. Record riding mileage;

88.8 km/h Displays real-time riding speed;



APP Bluetooth connection identifier. If the mobile phone app is connected with the Fiboard, and data transmission is normal, the identifier appears;



Remote control pairing identifier. The Fiboard was paired with the remote control when the identifier appears;



Fiboard body locking identifier. The app is used to activate and unlock for first-time use. The identifier will not appear later;



Current battery status of the Fiboard;



Temperature of the main control panel of the Fiboard;

② Driven wheel (front wheel);

③ Silicon rubber anti-slip cushion: Is firmly fastened to the surface of the Fiboard, anti-slip and cushioned;

④ Battery cover pull ring: For battery recharging or replacement, open the silicon rubber cushion, pull the pull ring backwards, open the battery cover board, and take out the battery;

⑤ Driving wheel (rear wheel): It provides driving force for the Fiboard by FOC sine wave control on the main control panel;

⑥ Aluminum alloy radiation fin;

⑦ Fiboard power switch: Shortly press the switch button. If the Fiboard display screen is on, the Fiboard is powered on;

⑧ Fiboard charging port: Insert the standard charger into the Fiboard charging port. A red charger indicator light means that the Fiboard is charging, and a green charger indicator light means that the Fiboard is fully charged;

⑨ Tail warning light: The remote control is used to remotely turn this light on and off. The default mode is flickering mode;

⑩ Front indicator light: The remote control is used to remotely turn this light on and off. The default mode is "continuously on" mode.

2-2 Specification parameters

Dimension specifications	790*196*130mm
Total weight	7.1kg
Plate material	Carbon fiber
Waterproof level	IPX5
Battery duration	25km (70kg load)
Maximum speed	32km/h
Climbing angle	20%
Maximum	130kg

loading bearing	
Applicable operating temperature	0-60°C



Battery case

Warning: Risk of electric shock or fire.

If the battery case contains moisture, there is a serious risk of electric shock or fire. Always keep clean and dry.



Driving wheels

Warning: Risks of burns.

Right after long-term use, do not touch the rear axle or driving motor. The driving motor produces heat and may cause serious burns. Cool down these areas before touching.

III. Introduction to battery

3-1 Schematic diagram and description of battery

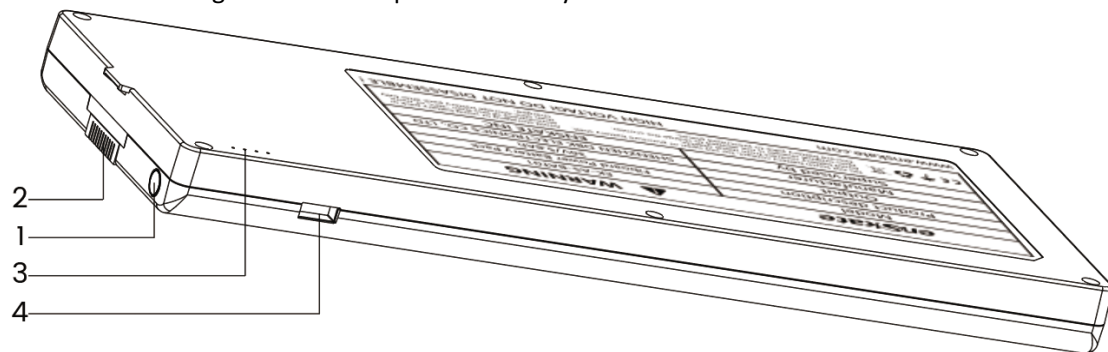

(Figure 3)

1. Battery indicator light button: Press the key. The indicator light turns on for 10 seconds, then check the battery status.
2. 36V power output port
3. Battery status indicator light: Four lights in total. Shortly press the power indicator light keys. The indicator lights are on for ten seconds: Four lights for 100% battery capacity, three lights for 75% battery capacity, two lights for 50% battery capacity, one light for 25% battery capacity. Recharging is recommended when only one light is on.
4. USB 5V 2.1A power output: Used to recharge mobile phones and remote control in case of emergency, and USB charging for other outdoor lighting equipment.

3-2 Power specifications and parameters

Specifications	325*125*25mm
Enclosure material	ABS engineering fire-resistant materials
Battery cell	LG 18650 2900mA
Voltage	36V
Capacity	36V 5.8Ah
USB output	5V 2.1A

3-3 Description of battery recharging:

Two modes are available for recharging battery:

Method 1: The battery is placed at the corresponding location of the Fiboard. the standard charger AC terminal is connected to the 100-240VAC socket. The DC terminal is inserted into the charging port at the bottom of the Fiboard. The charger indicator light turns red means the connection is normal and the battery is charging , until the charger indicator light turns from red to green. This means the charging is completed ,then remove all the plugs.

Method 2: Take the battery out of the Fiboard. Use the accompanied charging adaptor to connect the port for charging. The charger indicator light turns red means the connection is normal and the battery is charging , until the indicator light turns from red to green. This means the charging is completed ,then remove all the plugs. (Refer to the below figure).

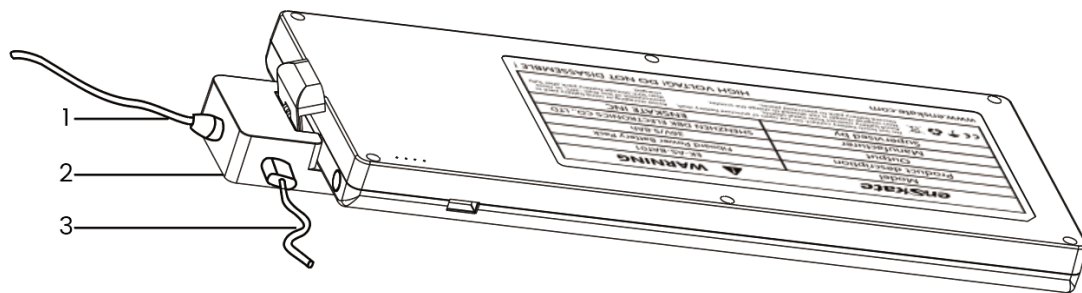

(Figure 4)

1. Charger output terminal
2. Charger conversion socket
3. USB 5V 2.1A output

Battery Handling & Disposal

Your Fiboard may not have a fully-charged battery when first received. Accordingly, you should charge the battery prior to the first use. The optimal conditions for use of the battery:

Temperature at 50-75F (10-24C), absolute humidity at 45-85%. 

NO RIDING AT/BELOW FREEZING TEMPERATURE

Never store or use the battery in freezing or below freezing temperatures.

Run time: Up to 60 minutes

Recharge time: 3 hours

Make sure the power switch is turned off whenever the Fiboard is not in use or the battery will deplete. When the battery is depleted, it is VERY susceptible to damage. When the Fiboard is not in regular use, recharge the battery at least once a month until normal use is resumed.

Use only the recommended charger and use with caution when charging. The charger should be regularly examined for possible damage to the cord, plug, enclosure or other parts. The charger should be operated only by an adult. Do not operate the charger near flammable materials. Unplug the charger and disconnect it from the Fiboard when it is not in use and charging is completed.

IV. Introduction of remote control

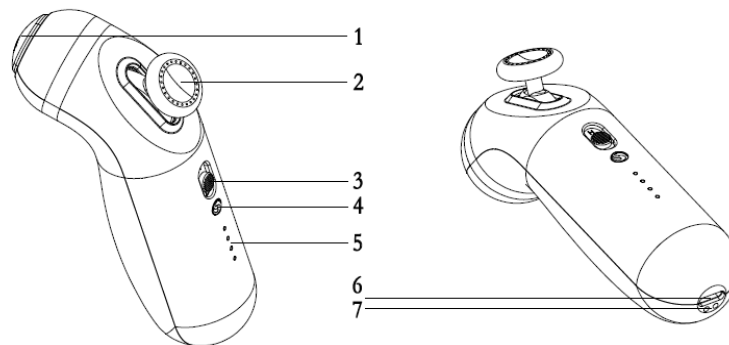

(Figure 5)

1. Remote control switch: Press for three seconds to turn on the remote control, and the battery capacity indicator of the remote control turns on. Shortly press and control the front and rear light statuses, which are: Front light On Rear light Flickering Front light On & Rear light Flickering Front and Rear light Off. Press for three seconds to turn off the remote control .

2. Accelerator rocker: The default position is neutral. Push forward to accelerate , pull backward to decelerate and brake. Keep at the same accelerator position for 10 seconds to enter cruise mode, and the “S” logo light will start flickering (Cruise mode need to activate on APP in advance).

3. High and low-speed switch : Push forward for high-speed mode, and pull backward for low-speed mode.

4. “S” logo 2.4G wireless status indicator light: Any movements of the rocker would arise the “S” logo , the “S” logo light will start flickering under the cruise mode.

5. Battery capacity indicator light of remote control:

Four lights indicate 100% battery capacity of remote control;

Three lights indicate 75% battery capacity of remote control;

Two lights indicate 50% battery capacity of remote control;

One light indicates 25% for battery capacity of remote control. Recharging is recommended when This means the charging is finished.

6. Type-C charging port: The adapter and a Type-C data cable are used to charge the remote control.

7. Remote control sling hole: The sling is used for carrying, and can be replaced.

Rated voltage	3.7V
Rated current	0.1A
Enclosure material	ABS engineering fire-retardant materials
Battery capacity	3.7V 600mAh

E. Radio Interference Precautions

The enSkate Fiboard incorporates a sophisticated communication system to ensure connection

between the remote controller and the skateboard. The connection could be unstable or lost when the remote controller's battery is low. Stop riding when the remote's low battery warning appears.

Try to avoid areas with high-power electromagnetic radiating equipment, such as radio towers, powerlines or radar. In some rare cases, connection may also be lost due to unpredictable causes. As a safety precaution, Fiboard will shut off immediately when the connection is lost. If a loss of connection happens more than once, stop use immediately and avoid using Fiboard again. Please contact enSkate for further assistance.

V. Prepare for riding

5-1 Installation of battery and powering on

Placement of battery

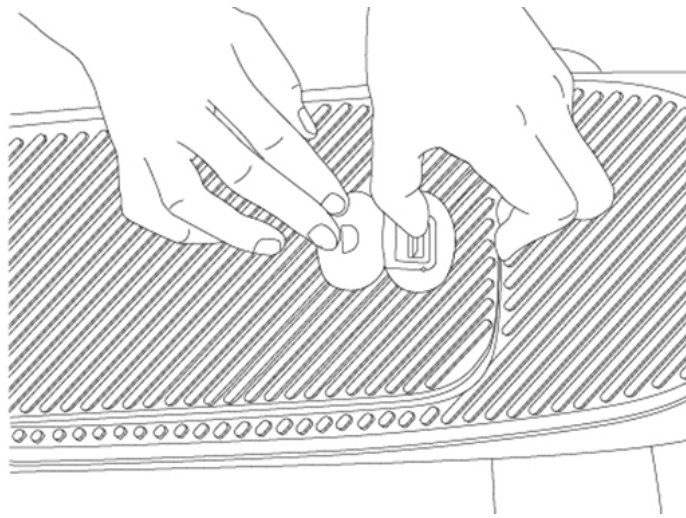

①、Open the battery cover

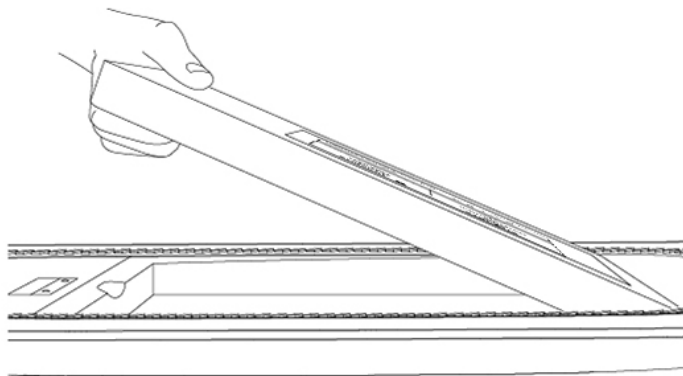

②、install battery

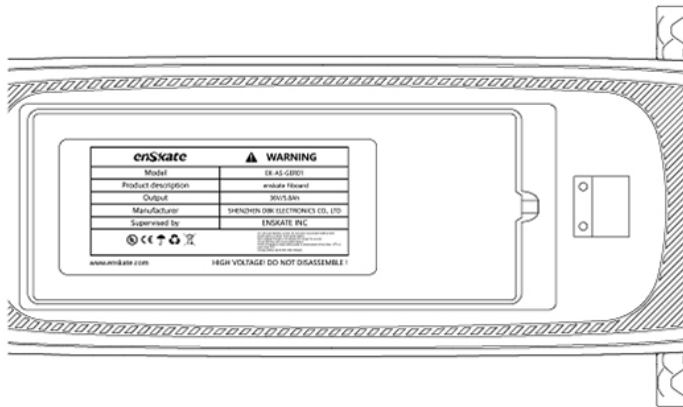

③、Ensure battery installed correctly

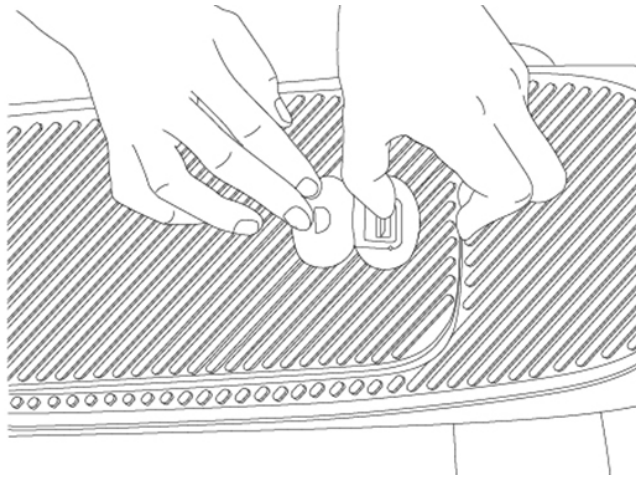

④、Close the battery cover

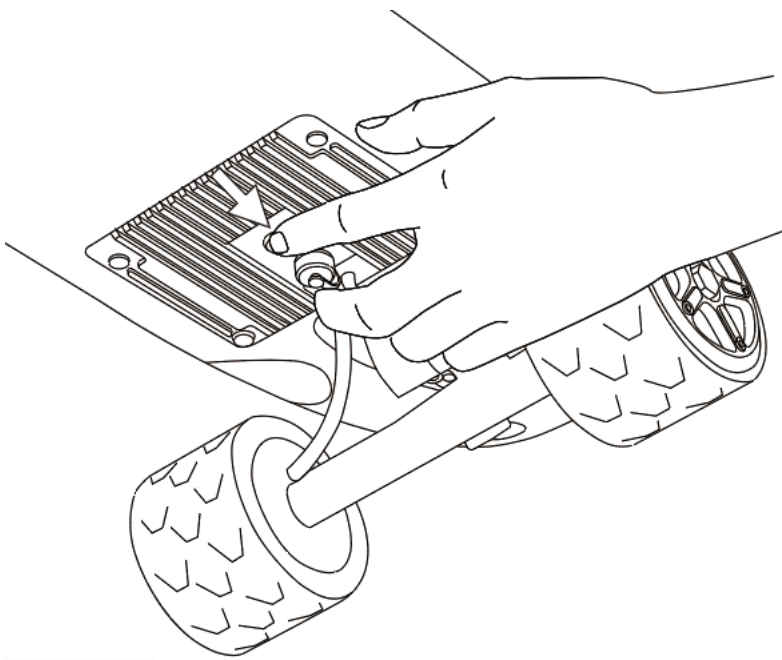

⑤、 Press the power switch of the Fiboard. After you hear the “clicking” sound, the Fiboard is turned on and the display screen is turned on. Press the switch for three seconds to turn off the power of the Fiboard.



Please notice that the battery connector must make contact with the connector in the battery case. If the battery is not placed completely, do not press down or secure the battery cover forcefully. In this situation, take out the battery , install properly the battery again.

5-2 Use the app to activate the device for the first time

Download enSkate APP. Register, log in and activate the device. Refer to Chapter VI APP Introduction and Use Instructions.

5-3 Switch on remote control and operation instructions

1. Press the power switch of the remote control for 3 seconds to turn on the remote control. Then check if there is any remote control identifier on the display screen of the Fiboard. Press the switch for three seconds to turn off the power of the remote control.

P.S.: If the remote control identifier is not found, the pairing operation must be executed: With the Fiboard power off, press the Fiboard switch key down for 10 seconds to enter pairing mode, and on the display appears a flickering “- -” Turn on the remote control, and push the accelerator rocker to the top position for 10 seconds. On the display appears P1, P2, P3....P10. Then the remote control identifier (identifier) and the orange indicator light on the remote control turn on. After the pairing is successful and the accelerator rocker is reset, push and pull the accelerator rocker to control the motor.

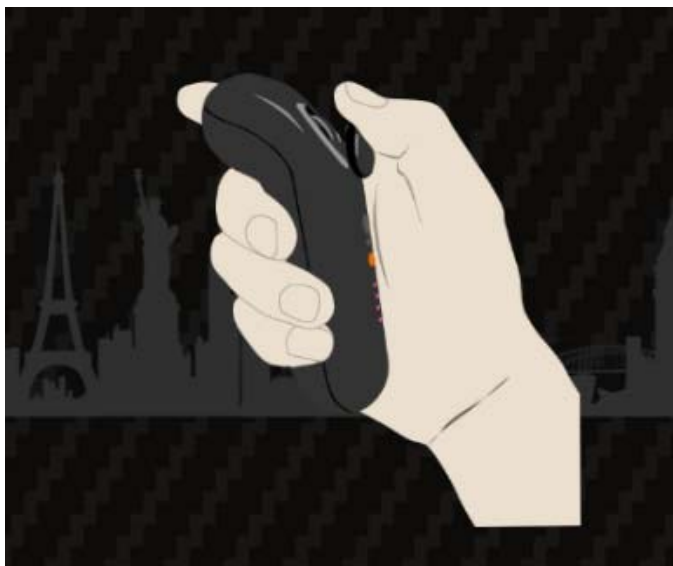

2. The default speed of the Fiboard is set to beginner mode (0-15km/h). Firstly, as shown in the above figure, pull the remote accelerator rocker to the minimum braking position, so that the dynamic wheel is under damping braking status.



3. Prepare for riding and keep the correct riding mode. As shown in the figure, according to individual customs, step on the Fiboard; place both feet on the Fiboard, keep knees bend and look ahead.

4. After moving into a stable standing position, push the accelerator rocker to the middle position. Push the accelerator upwards slowly until the Fiboard moves slowly and keeps sliding conditions. After stabilizing, push the accelerator forwards or backwards to adapt speed levels and brake sensitivity.

5. Regular light and warning light: Ensure the Fiboard and the remote controller are turned on, press the key to control the front and rear light, and cycle through to the following modes:

Front light On 🔆 Rear light Flickering 🔆 Front light On & Rear light Flickering 🔆 Front and Rear light Off

Notes: Under default mode, the remote control has been paired and is in beginner mode. Do not push the accelerator rocker quickly before operating skillfully; the default mode of the app is novice mode, which can be changed after you have become familiar with it.

VI. APP downloading, introduction and cautions

6-1: Please search and download "enskate" on APP store

6-2: Register and log in with email address.

6-3: Register and log in to beginner mode , slide right or left to find the "Find equipment" interface .

Novice tutorial

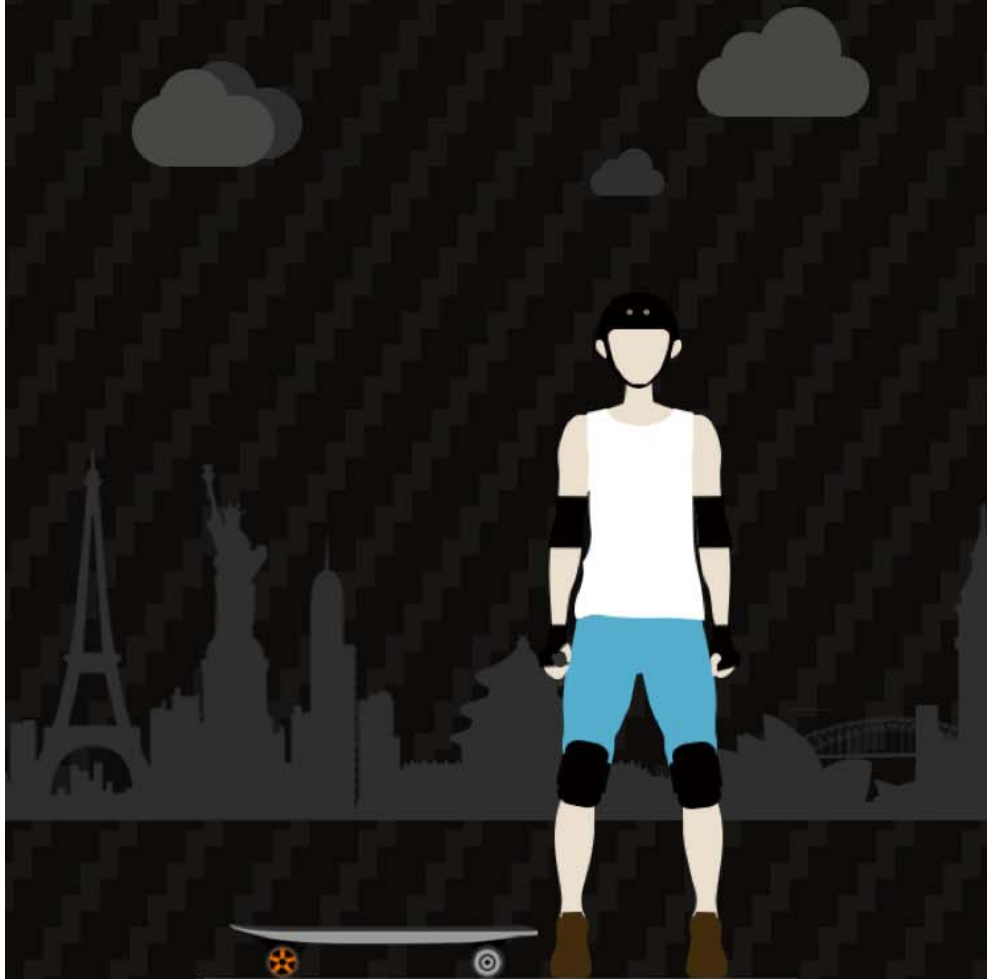

Please wear protection while riding



Step 1

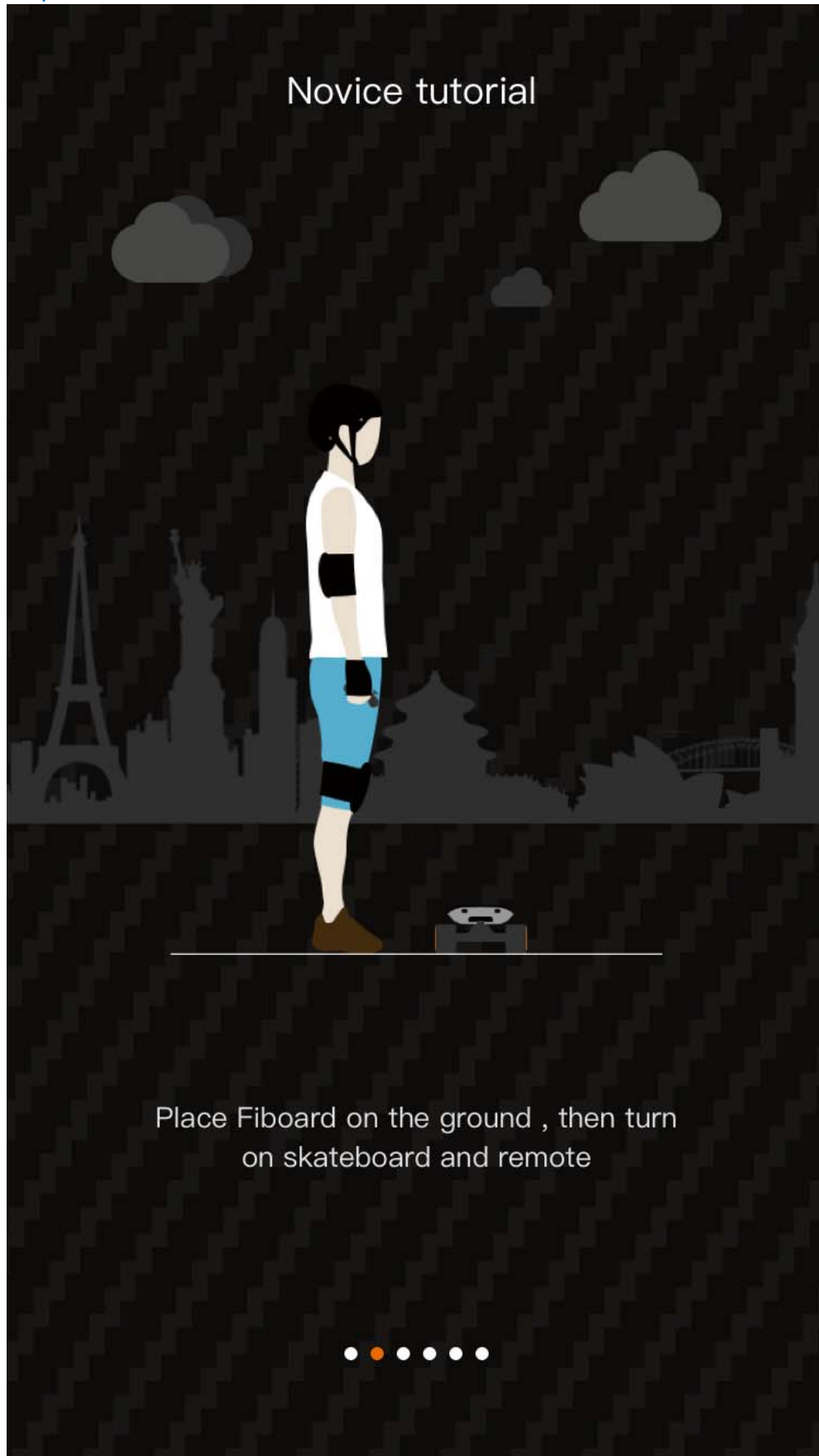

Step 2

Novice tutorial



Pull the rocker as shown for
beginner's mode



Step 3

Novice tutorial

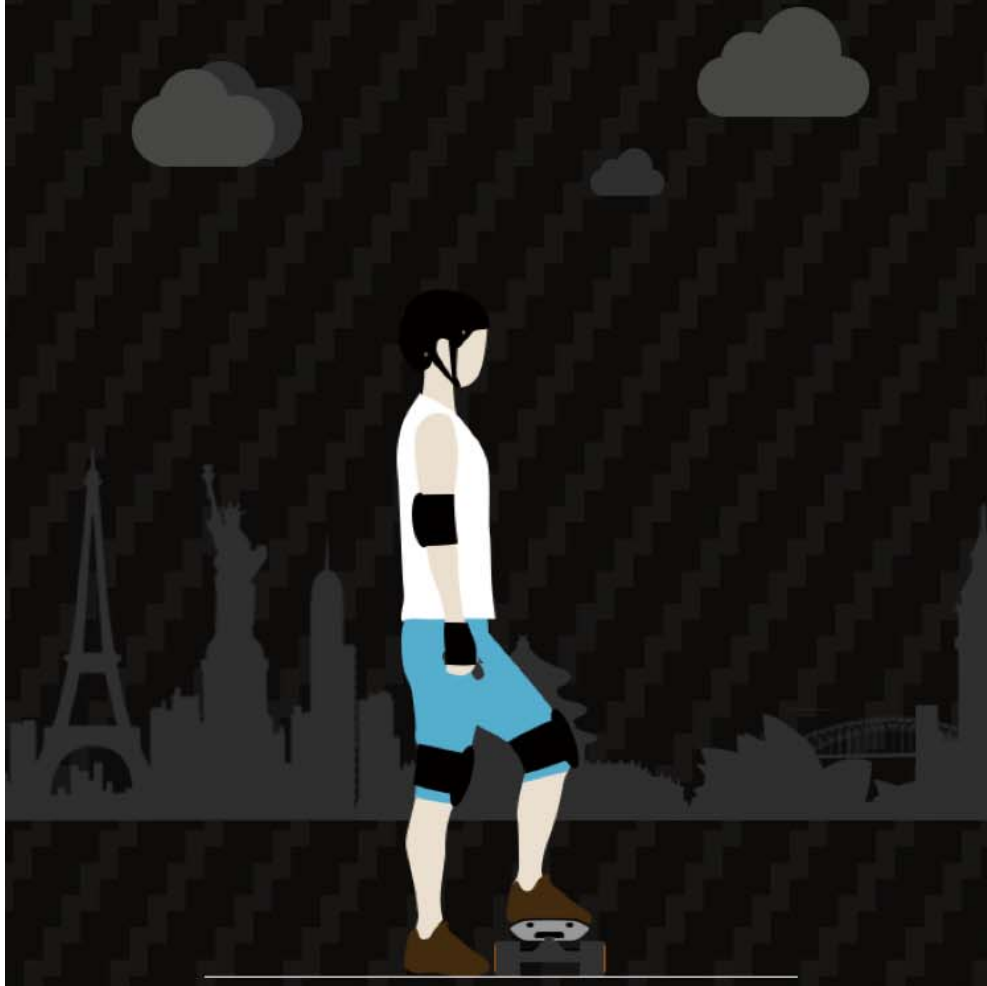

Your dominant foot should be your front
foot and get on skateboard first



Novice tutorial

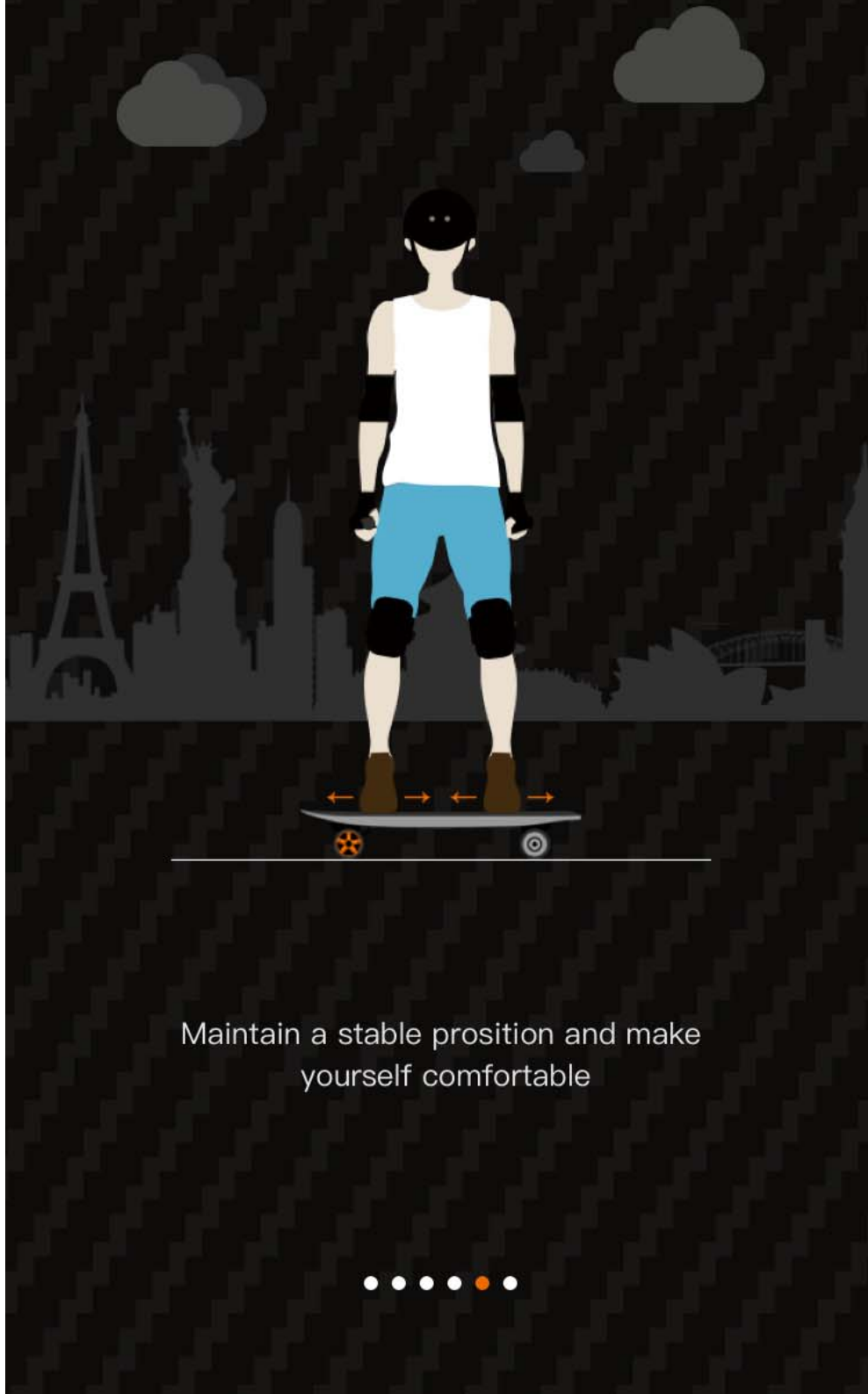

Maintain a stable position and make yourself comfortable



Novice tutorial

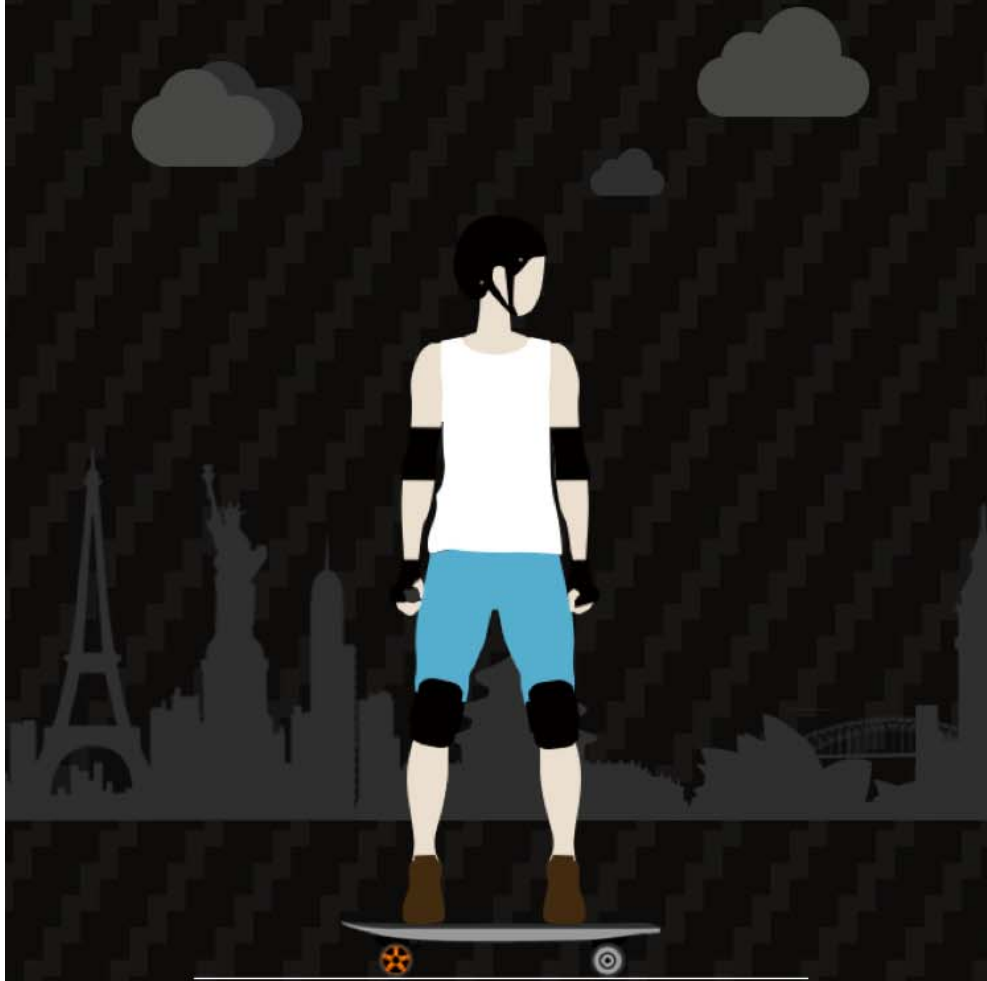

Keep your eyes facing forward when riding
keep knees bent, practice slowly until
getting familiar with Fiboard



t

6-4: Add equipment

After check the page for beginner mode to enter the interface of “find equipment” as the following pics of operation .

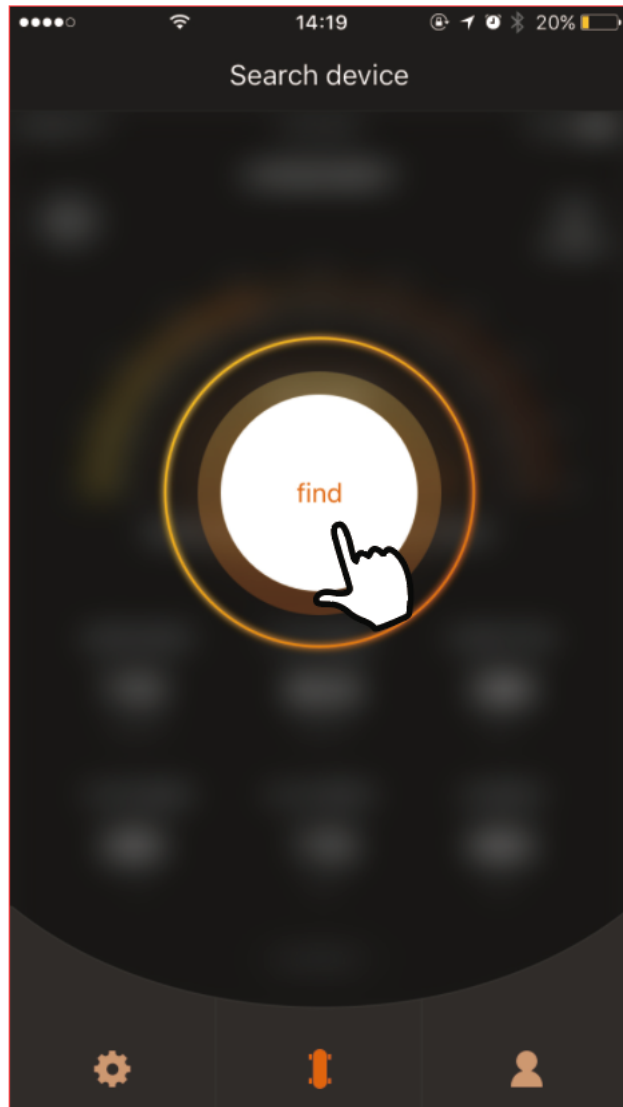

Step 1

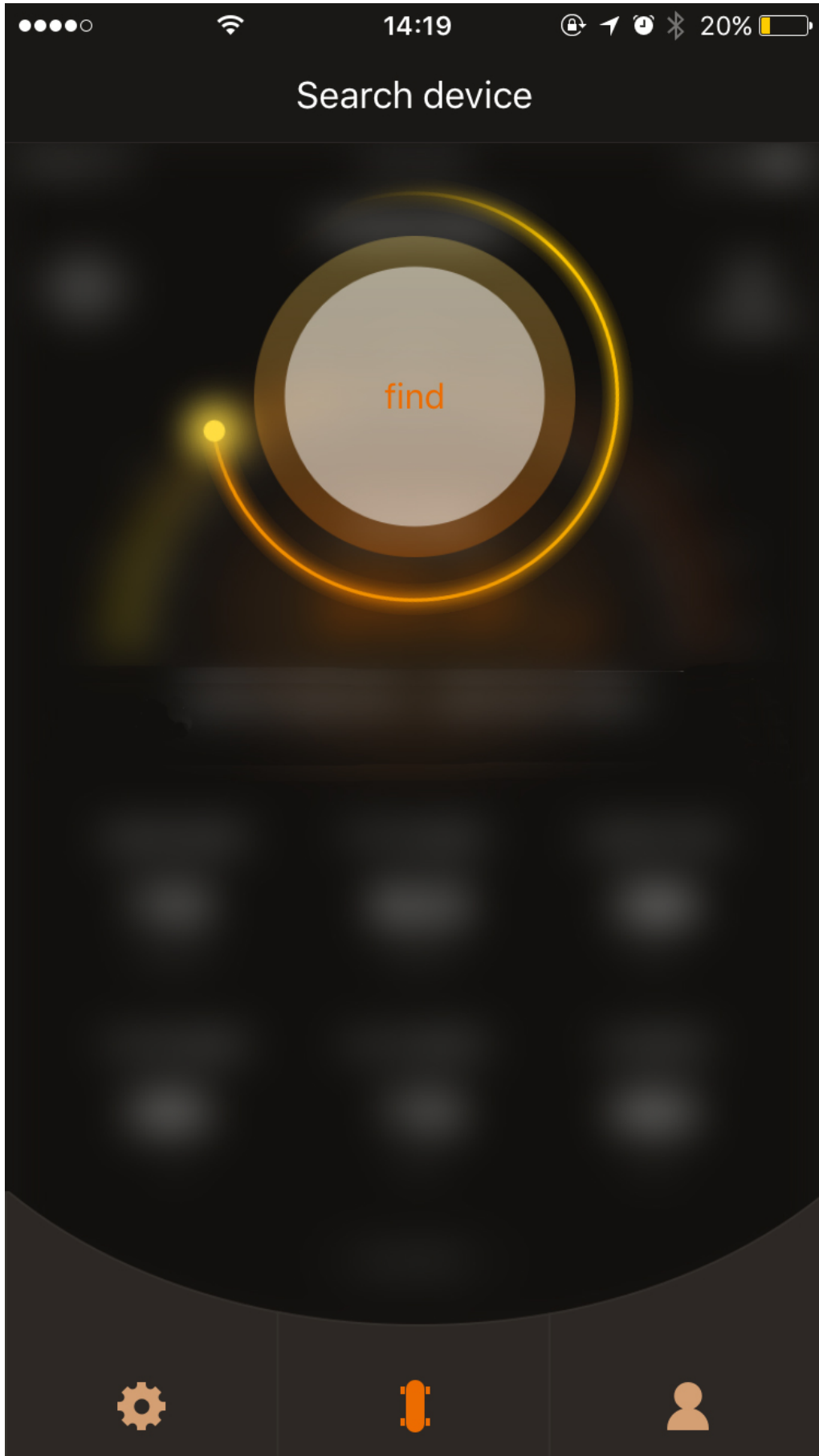

Step 2

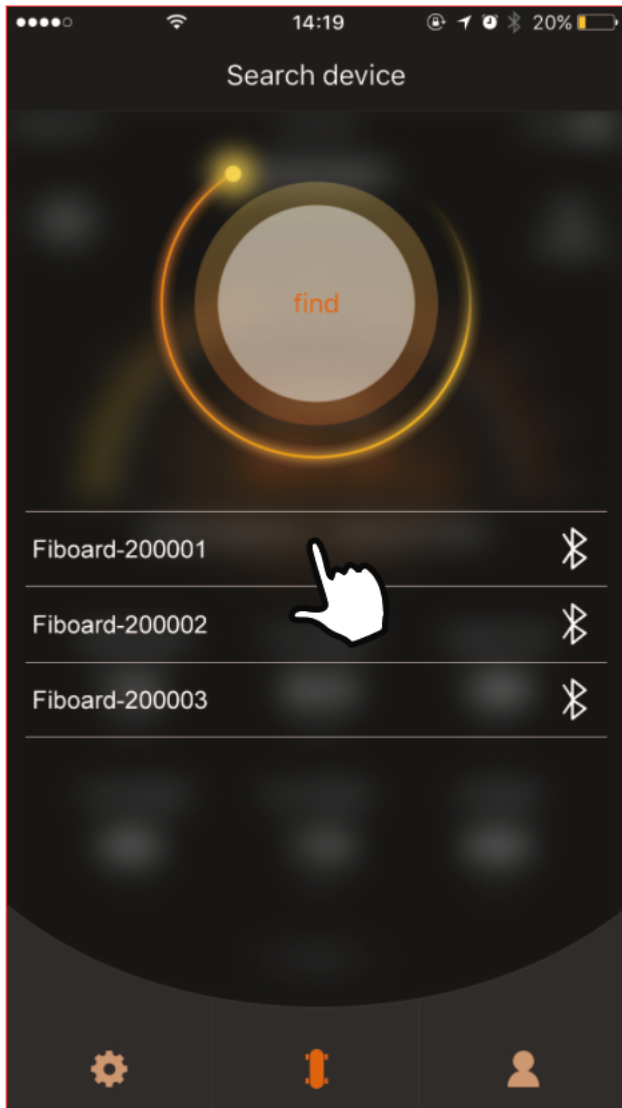

Step 3



Connect device

Enter Default password

6 digits password (can be changed)

forget password

Cancel Confirm

Fiboard-200001



Step 4

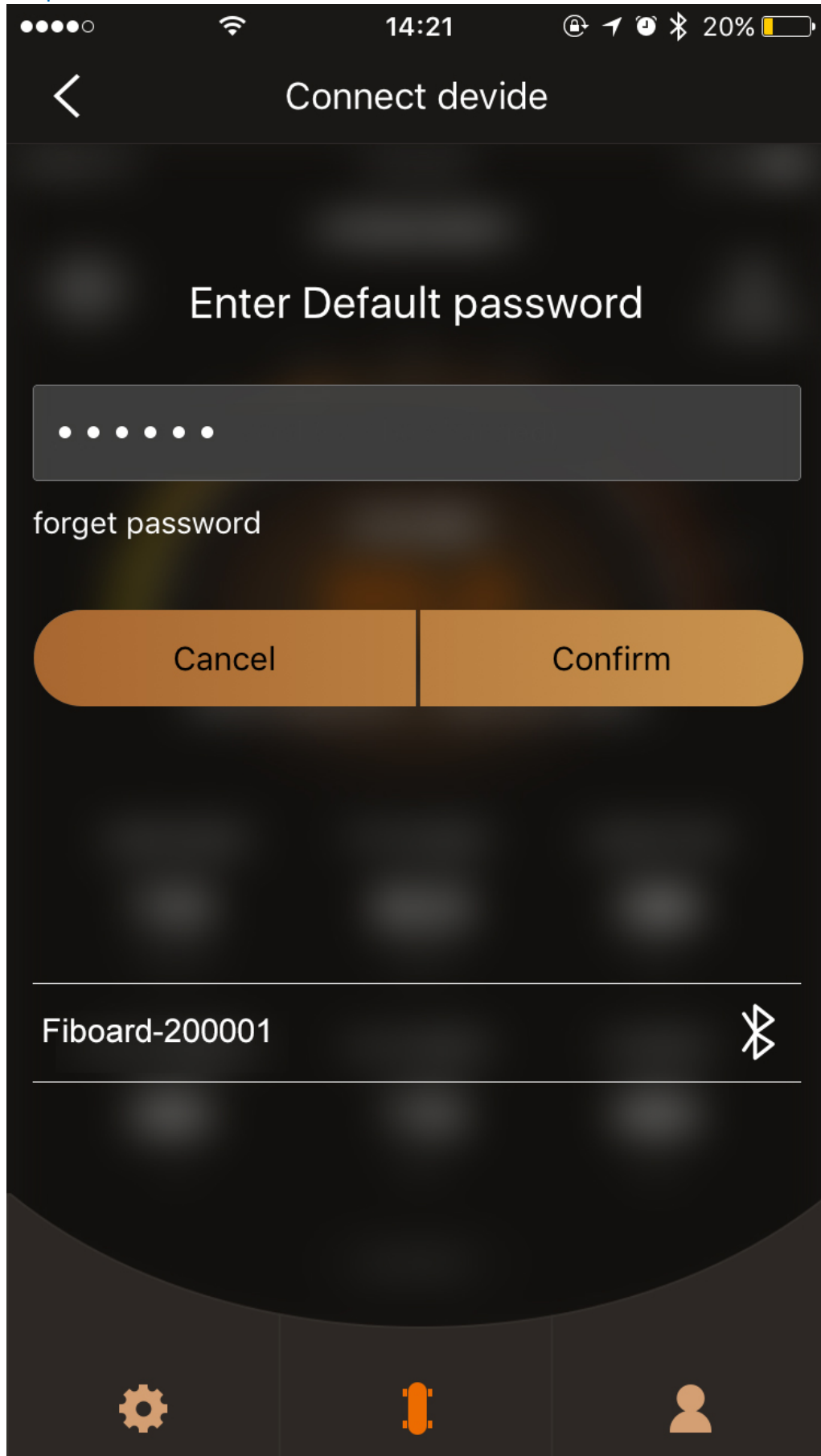

Step 5

6-5 :Main interface

Current power , current speed , highest speed , average speed , range to go , temperature of mainboard , current mileage , total mileage are all could be check on the main interface .

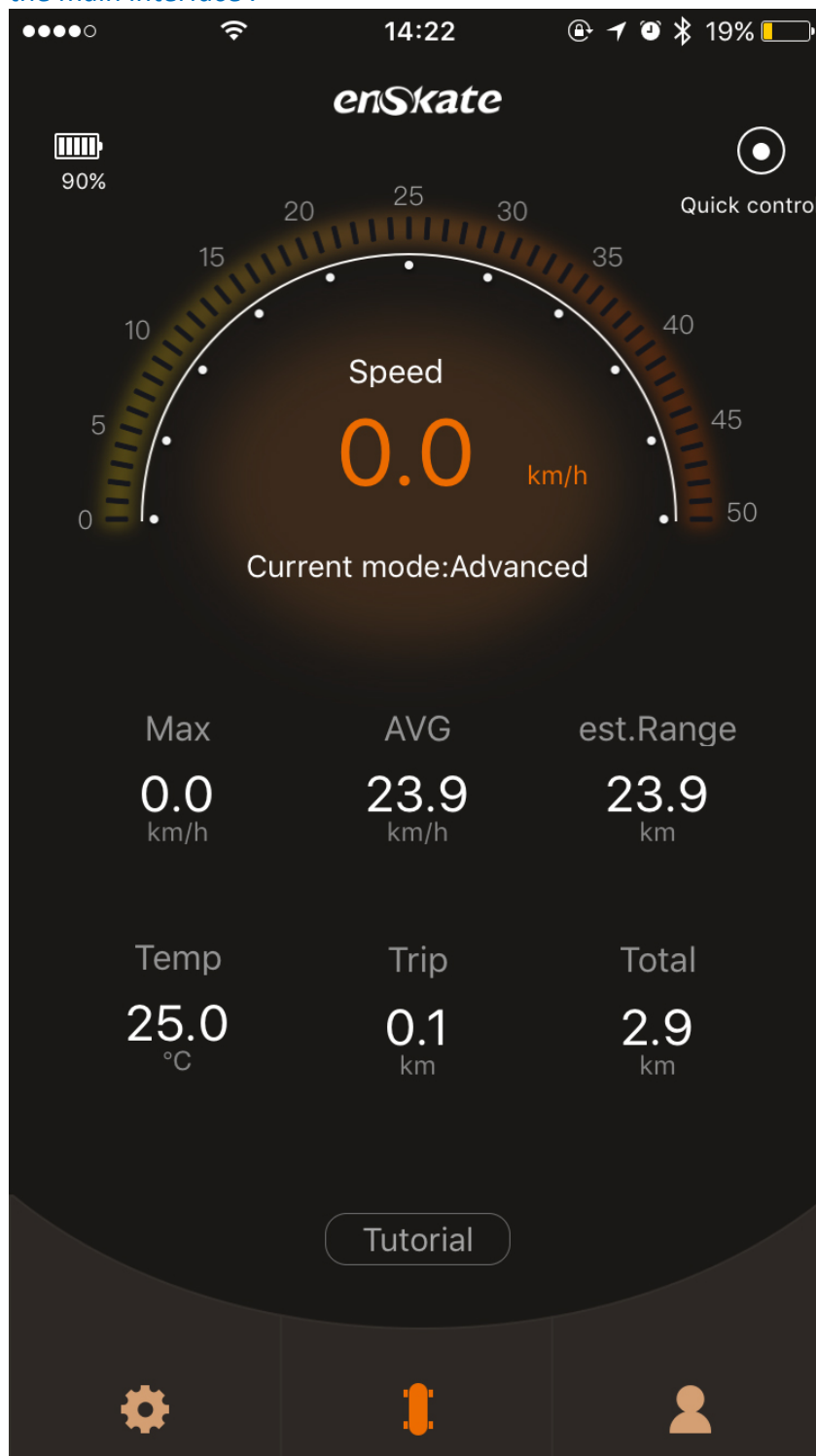

6-6 :App operation

Ensure the App was connected with the board , press “Quick operate” to enter

the operation interface , push and pull the rocker to forward , accelerate , decelerate , brake and etc .



Step 1



14:22



Quick control

0.0 km/h

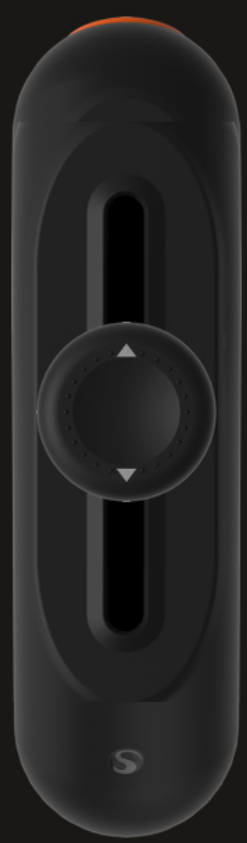

Current mode: Advanced

90 Battery %

22.8 AVG km/h

Advanced

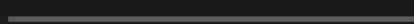

0-32km/h

Step 2

6-7-1 : User information setting

Press  to enter the personal setting interface to setting the personal information , share , range and B2B .



Step 1

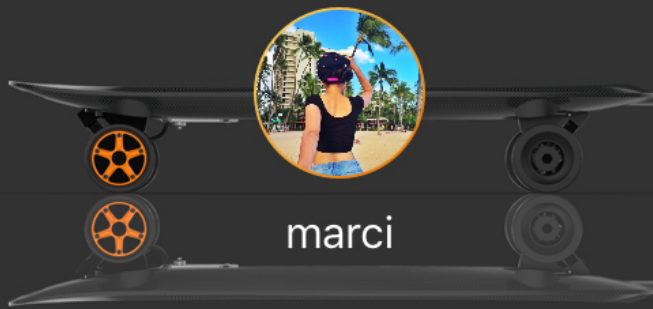

 My moments >

 Trip record >

 STORE >

 Log out >



Step 2

6-7-2 : Parameter setting

Press  to enter the parameter setting interface , change the riding mode , password management , cruise mode setting , unit switch and etc .

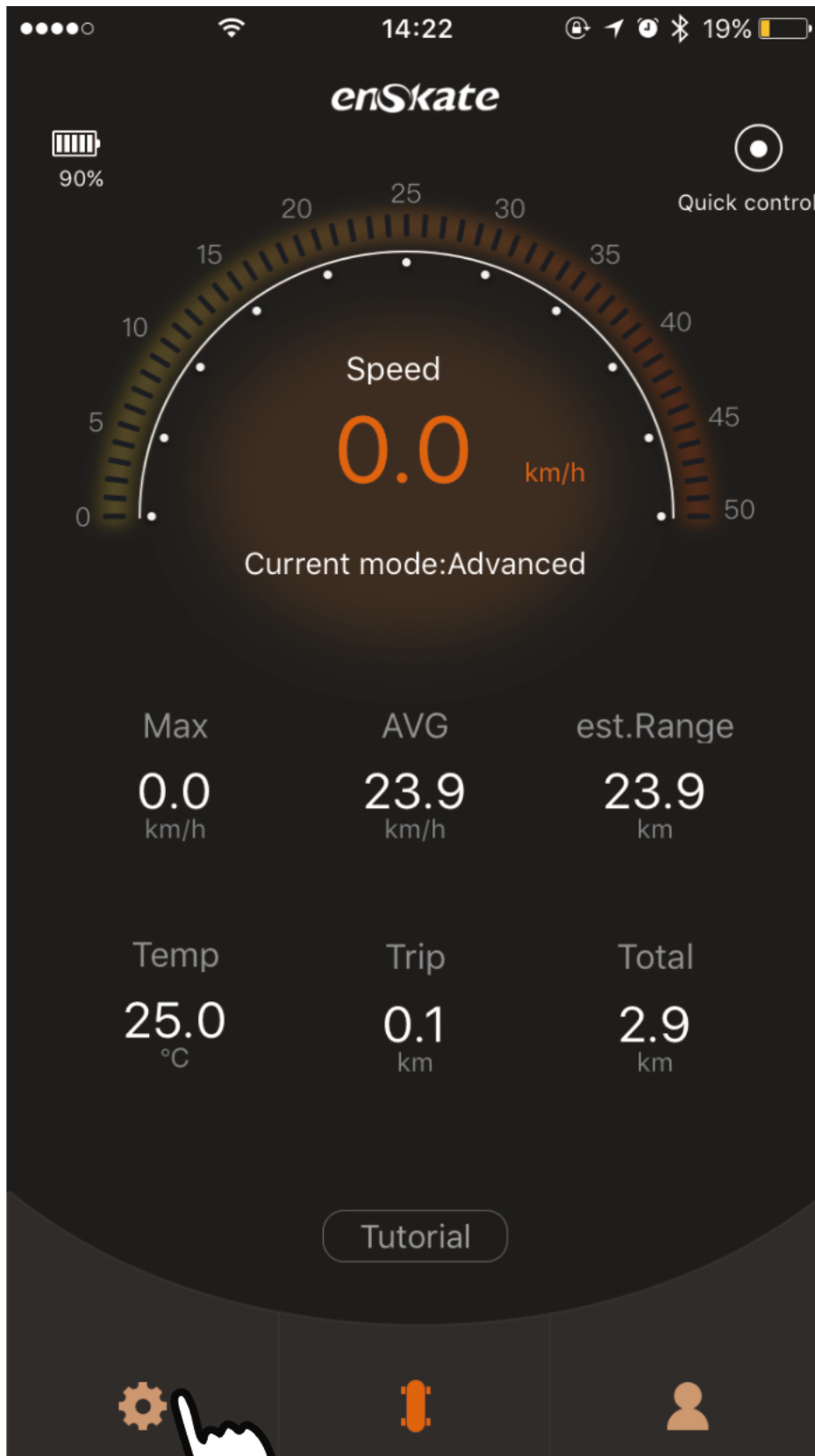

Step 1

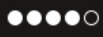

14:23



19%



Setting



Speed Setting



Password



Fiboard password



Cruise control



Units setting



Basic info



Step 2

6-8

For more details please land : <http://www.enskate.com/privacy-policy/>



APP cautions:

Warning: When you operate enSkate APP programs, you should set your mobile phone to Airplane mode. If you receive a call or notice when you operate the accelerator within the operation program, you cannot control Fiboard anymore. We recommend that you control the Fiboard with the remote control.

VIII. OPERATING LIMITS

It is important that you familiarize yourself with the operating limits of the enSkate Fiboard. These limits are set to maximize rider safety and reduce the risk of damage to the enSkate Fiboard. The enSkate Fiboard will perform better when you observe these limits.

WEIGHT LIMITS FOR RIDERS AND CARGO

enSkate sets weight limits for two reasons:

- Rider safety
- To reduce the risk of damage to the enSkate Fiboard

CAUTION: Exceeding the weight limit, especially in situations requiring more power when combined with other variables, will increase your risk of reducing the speed range of your Fiboard or damaging your Fiboard.

Variables that require more power include:

- Higher payloads (weight of rider and all cargo)
- Steeper slopes
- Bumpy or rough surface conditions
- Excessive starting, accelerating, and stopping
- Abrupt maneuvers

STRUCTURAL WEIGHT LIMITS (MAXIMUM PAYLOAD)

The maximum payload (rider plus all cargo) is 286 lbs (130 kg). Exceeding the maximum weight limit increases the risk of damage to the enSkate Fiboard. Heavier payloads place greater stress on the enSkate Fiboard.

Several factors affect the loads transmitted to the enSkate Fiboard

- Skill level of the rider
- Payload (weight of the rider and all cargo)
- Surface condition (obstacle height, etc.)

NOTICE: Exceeding the rider or cargo weight limits, especially when riding on uneven terrain, could damage the enSkate Fiboard or lead to decreased performance under the excessive load.

MAXIMIZING RANGE

Maximum range distances are provided in the Technical Specifications section. The range of your

enSkate Fiboard is affected by many variables, including:

- Terrain: Riding on smooth, flat terrain improves range, and riding on hilly terrain and unpaved surfaces reduces range.
- Speed and Riding Style: Riding at a consistent, moderate speed will increase range. Excessive starting, stopping, acceleration, and deceleration reduces range.
- Rider Weight and Cargo: Lighter riders with less cargo experience better range than heavier riders with more cargo.
- Temperature: Storing, charging, and riding in temperatures close to the median of the recommended temperature range improves range. Riding in colder temperatures reduces range significantly.
- Battery Condition: Properly charged and maintained batteries provide greater range. Old, cold, heavily used, or poorly maintained batteries provide less range.

IX. TROUBLESHOOTING

If your Fiboard is not running properly, stop using it immediately. In most cases, turning the skateboard off for ten seconds and restarting it will solve the issue. If you find other problems, or restarting the Fiboard doesn't resolve the issue, refer to the following chart for common troubleshooting methods. If the problem still exists, please stop using the Fiboard and contact enSkate.

Trouble	Probable Cause	Solution
Not turned on	Low Battery	Charge battery for at least one hour
Not riding	The remote control is not connected or not turned on	Restart the remote and skateboard
	Skateboard/remote in sleep mode	Shut both down for ten seconds, then turn on again ten seconds later
Not charged	Charger not connected	Make sure you're using the correct charger and that it is properly connected to an outlet
	Battery depleted	If battery has not been charged for more than a month, it may require an extra hour to start normal charging
Range too low	Exceeded the weight limit	Fiboard is designed for a person who weighs up to 286lbs
	Battery health dropped	It is possibly required to replace the battery pack
Vibration and noise	Loose screws	Change belt
	Wheel/Bearing has worn down	Replace wheel/bearing

IX. OTHER SAFETY WARNINGS



SAFETY WARNINGS

A. General Disclaimer

Riding enSkate Fiboard can be a dangerous activity. Certain conditions may cause the equipment to fail without fault of the manufacturer. Like other electric transportation products, enSkate Fiboard is intended to move and accordingly it is possible for the rider to lose control, fall, collide with other objects, and/or get involved in dangerous situations, without complete care, instruction or professional knowledge to remove the danger. If this occurs, even if safety equipment or other preventive measures are used, it may cause serious injury or even death.

RIDE AT YOUR OWN RISK AND USE COMMON SENSE.

This manual contains many warnings and cautions concerning the consequences of failing to maintain, inspect or properly use your enSkate Fiboard. We repeat: any accident may result in possible serious injury or death.

WEAR HELMET AND PROTECTIVE GEAR AT ALL TIMES.



B. Age, Weight & Health

enSkate Fiboard is designed for adults and for older teens. The recommended rider age is 16 years or older. Keep enSkate Fiboard away from small children and young teens.

DO NOT ride the board if you are under the influence of alcohol or drugs.

DO NOT EXCEED THE WEIGHT LIMIT OF 286 LBS.

C. Conditions for safe riding

Where enSkate Fiboard may be used. Ride defensively. Watch out for potential obstacles that could catch your wheels, force you to swerve suddenly, or lose control. Be careful to avoid pedestrians, inline skaters, motor vehicles, other skateboarders, scooters, bikes, children or animals that may enter your path.

Always wear proper protective equipment such as an approved safety helmet (with chin strap securely buckled), wrist guards, elbow pads, and knee pads. A helmet may be legally required by local law or regulations in your area. A long-sleeved shirt and long pants are recommended. Before riding, be sure to check that all wheels, trucks and the battery case are secured properly.

WARNING: AVOID WATER 

enSkate Fiboard is not water-proof. Do not ride in the rain, in wet or icy weather, as the electrical and drive components could be damaged. Always ride on dry, paved surfaces.

NO TRICKS  

Do not attempt or do stunts or tricks on your Fiboard. Fiboard is not made to withstand abuse from misuse such as jumping, curb grinding or any other types of stunts. Fiboard can break from the stress incurred by these activities. Any such misuse will void the warranty.

KEEP fingers, hair, and clothing away from motors, wheels and all other moving parts.

FCC Notice:

NOTE: This equipment has been tested and found to comply with the limits for a Class B digital device, pursuant to Part 15 of the FCC Rules. These limits are designed to provide reasonable protection against harmful interference in a residential installation. This equipment generates uses and can radiate radio frequency energy and, if not installed and used in accordance with the instructions, may cause harmful interference to radio communications. However, there is no guarantee that interference will not occur in a particular installation. If this equipment does cause harmful interference to radio or television reception, which can be determined by turning the equipment off and on, the user is encouraged to try to correct the interference by one or more of the following measures:

- Reorient or relocate the receiving antenna.
- Increase the separation between the equipment and receiver.
- Connect the equipment into an outlet on a circuit different from that to which the receiver is connected.
- Consult the dealer or an experienced radio/TV technician for help.

WARNING: Changes or modifications not expressly approved by the party responsible for compliance could void the user's authority to operate the equipment.

RF Exposure

The equipment has been evaluated to meet general RF exposure requirement. The device can be used in portable condition without restriction.